

Installation, Operation, & Maintenance

IOM 4603
Rev. C 10/25

*CD*Q, *CD*QX, *CD*QR, *CD*QXR SERIES FAN COIL UNITS

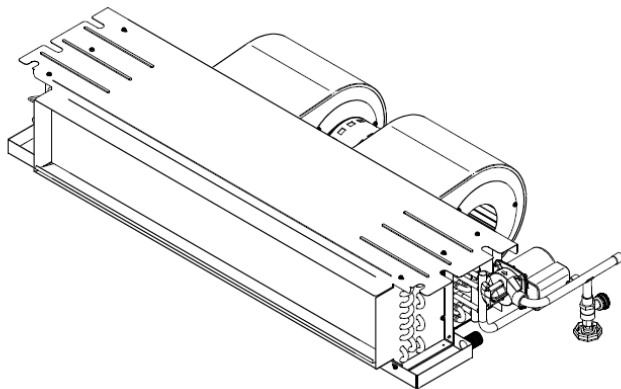

ATTENTION:

Read all instructions thoroughly and retain all manuals for future reference.



COPYRIGHT

The Manufacturer works to continually improve its products and as a result, it reserves the right to change design and specifications without notice.



WARNING



Altering the product or replacing parts with non-authorized factory parts voids all warranty or implied warranty and may result in adverse operational performance and/or a possible hazardous safety condition to service personnel and occupants. Company employees and/or contractors are NOT authorized to waive this warning.



WARNING



Only personnel trained and qualified in the installation, adjustment, servicing, maintenance, or repair of the equipment described in this manual should perform service. The manufacturer is NOT responsible for any injury or property damage arising from improper service or procedures. In jurisdictions where licensing is required to service this equipment, only licensed personnel should perform the service.

Improper installation, adjustment, servicing, maintenance, or repair—or attempting to perform these tasks without proper training—may result in product damage, property damage, personal injury, or death. Service personnel assume responsibility for any injury or property damage resulting from improper procedures.

TABLE OF CONTENTS

SAFETY CONSIDERATIONS	4
SAFETY INFORMATION	5
MODEL NOMENCLATURE	6
INSTALLATION PRECAUTIONS	7-8
LOCATION & CLEARANCE	8
GENERAL	9
FAN COIL UNIT	9-10
AIR DISTRIBUTION DUCTS	10
STATIC PRESSURE	10
DIMENSIONS	11
ELECTRICAL	12-13
WIRING DIAGRAMS	14-16
HOT WATER COIL PIPING PRECAUTIONS	16
HOT WATER COIL PIPING INSTALLATION	17
COOLING COIL PIPING	18
PRE-STARTUP CHECKS	19
HEATING CYCLE START-UP	20
MOUNTING	21
LEAK CHECKS	22
REFRIGERANT CHARGING	22-23
OPERATION & MAINTENANCE	24-29
MINIMUM ROOM SIZE & MITIGATION AIRFLOW	30
A2L SENSOR REPLACEMENT	31
MASSACHUSETTS COMBO SYSTEM LAYOUT	32
NOTES	33

SAFETY CONSIDERATIONS



1. **READ THE ENTIRE MANUAL BEFORE STARTING THE INSTALLATION.**
2. Improper installation, adjustment, alteration, service, maintenance, or use can cause explosion, fire, electrical shock, or other conditions which may cause personal injury damage.
3. Consult a qualified licensed installer, service agency, or your distributor for information assistance. The qualified licensed installer or service agency must use factory-authorized kits or accessories when servicing this product.
4. Refer to the individual instructions packaged with kits or accessories when installing.
5. Follow all safety codes.
6. Read these instructions thoroughly and follow all warnings or cautions attached to the unit. Consult local building codes and National Electrical Code (NEC) for special requirements.

This appliance is NOT to be used by persons (including children) with reduced physical, sensory, or mental capabilities, or lack of experience and knowledge, unless they have been given supervision or instruction.

Children should be supervised to ensure that they do NOT play with the appliance.

Use adequate personal protection equipment when installing and performing maintenance. After switching off and locking-out an electrical disconnect, verify a safe condition with an electrical tester. Discharge a capacitor before handling any PSC motor and wiring. Use eye protection, cut resistant gloves and sleeves to protect against metal edges and screws.

RECOGNIZE THE FOLLOWING SAFETY NOTATIONS THROUGHOUT THIS MANUAL AND POSTED ON THE EQUIPMENT:

	WARNING	
Indicates a potentially hazardous situation or unsafe practices that could result in severe personal injury or death and/or damage to property.		

	WARNING	
	ELECTRIC SHOCK HAZARD	
This warning signifies potential electrical shock hazards that could result in personal injury or death.		



	CAUTION	
Indicates a potentially hazardous situation that may result in minor or moderate personal injury.		

	IMPORTANT	
Suggests important procedure steps to insure proper installation, reliability, or operation.		

	NOTE	
Used to highlight suggestions, which may result in enhanced installation, reliability, or operation.		

	Service indicator; read technical manual
	Operator's manual; operating instructions
	Read the instructions
	Warning; flammable materials
	UN GHS flame symbol



SAFETY INFORMATION

 **WARNING** 

 Risk of fire. Flammable refrigerant used. To be repaired only by trained service personnel. Do NOT puncture refrigerant tubing.



Auxiliary devices which may be ignition sources shall NOT be installed in the ductwork, other than auxiliary devices listed for use with the specific appliance. See Instructions. Dispose of refrigerant properly in accordance with federal or local regulations.

Failure to follow proper A2L refrigerant mitigation system installation instructions can result in property damage, personal injury, or death. If any fault indicators are present, please troubleshoot to prevent system malfunction.



 **WARNING** 

When a Refrigerant Leak Detection System is installed. The unit must be powered on at all times except for serving.



Installer must verify that the refrigerant sensor is properly installed and functioning or else the warranty will be voided. Failure to do so may result in fire, property damage or death.

 **WARNING** 

Work with extreme caution to minimize the risk of refrigerant ignition while installing and servicing a system containing a flammable refrigerant. Control the work environment as much as possible while potentially flammable vapors are present. Inform all persons on site about the risks of the nature of the work underway and the necessary safety precautions. Do NOT work in confined spaces. Test the work area for refrigerant in the air using an intrinsically safe A2L refrigerant leak detector before beginning work. Have a dry powder or CO2 fire extinguisher available. Use proper tools designed for A2L class refrigerants. While working near A2L refrigerants, use only non-sparking tools. Open flames and other ignition sources must NOT be present except during brazing. Brazing must only take place on evacuated and nitrogen purged refrigerant lines and components that are open to the atmosphere.

 **WARNING** 

These instructions are intended to aid qualified, licensed, service personnel in proper installation, adjustment, and operation of this unit. Read these instructions thoroughly before attempting installation or operation. Failure to follow these instructions may result in improper installation, adjustment, service, or maintenance possibly resulting in fire, electrical shock, property damage, personal injury, or death.

 **WARNING** 



Electrical work associated with the installation of this appliance must comply with the National Electrical Code (NEC). Other local or regional electrical and building code requirements may apply.

In Canada electrical work associated with the installation of this appliance must comply with CE CSA C22.1.



 **IMPORTANT** 

This fan-coil must be installed in a location which is not accessible to the general public.

This appliance is for **INDOOR USE ONLY**.

 **WARNING** 

 When the unit is using flammable refrigerant and is installed in a room with an area less than that outlined in section **Minimum Room Size and Mitigation Airflow**, that room shall be without continuously operating open flames or other potential ignition sources.

 **WARNING** 

 Auxiliary devices that may serve as potential ignition sources must NOT be installed in the ductwork. Potential ignition sources include hot surfaces exceeding 700°C and electrical switching devices.

MODEL NOMENCLATURE

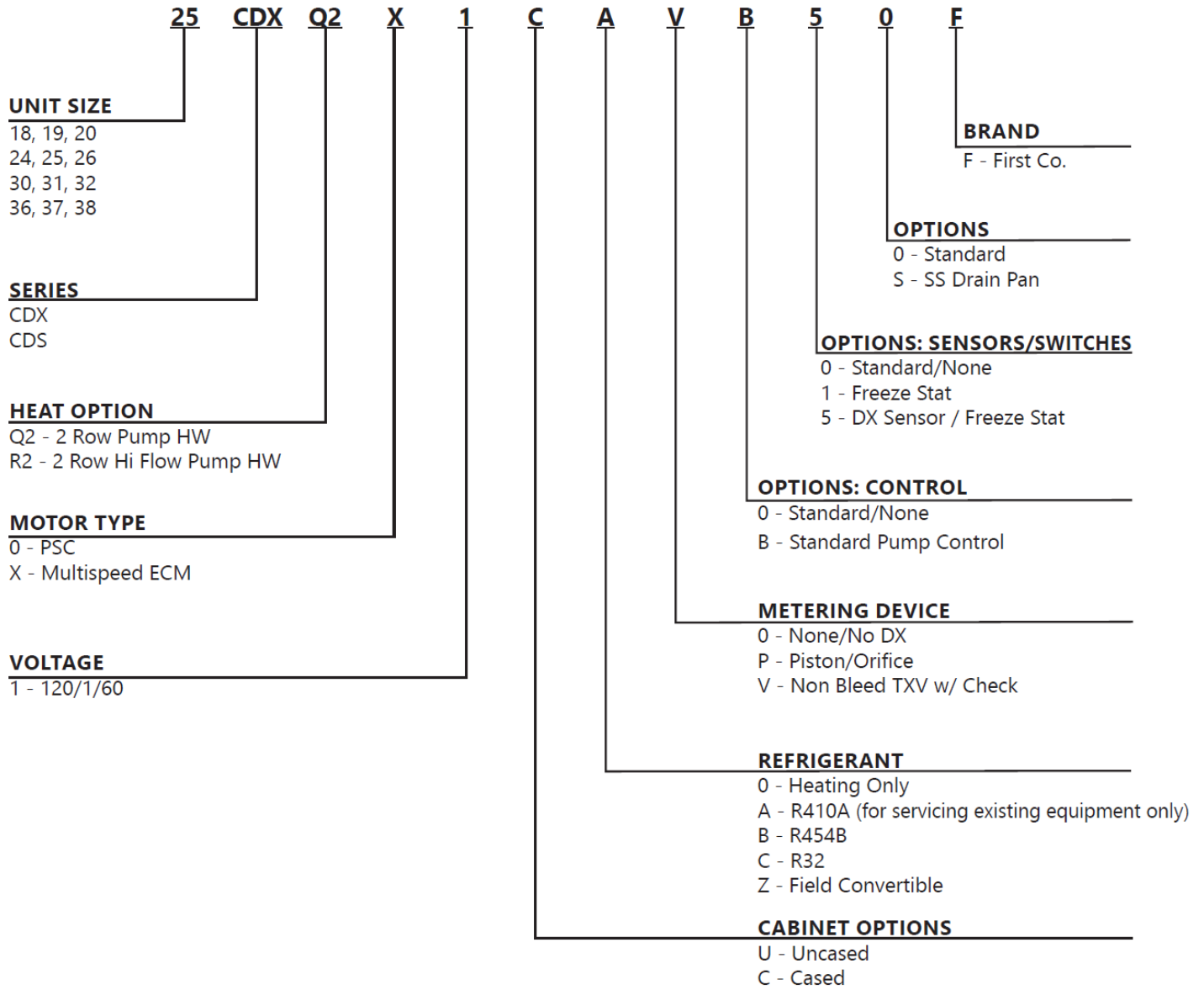

Figure 1 – Model Nomenclature

INSTALLATION PRECAUTIONS



WARNING



If hot water coil is connected to domestic potable water, a hot water mixing valve can be applied to the system to temper domestic water draw.



WARNING



Use two or more people when moving and installing these units. Failure to do so could result in personal injury or death.

Use gloves when handling equipment. Contact with metal edges and corners while applying excessive force can result in personal injury. Use caution during installation or while servicing equipment.

Installation of this fan coil should be performed only by a licensed contractor to ensure proper installation and the safety of the installer.

Observe the following precautions for typical installations:

- Always use proper tools and equipment.
- No wiring or other work should be attempted without first ensuring fan coil is completely disconnected from the power source locked out. Always verify that a good permanent, uninterrupted ground connection exists prior to energizing any power sources.
- Always review the nameplate and wiring diagram on each unit for proper voltage and control configurations. This information is determined from the components and wiring of the unit and may vary from unit to unit.
- When soldering or brazing to the unit, it is recommended to have a fire extinguisher readily available. When soldering close to water vales or other components, heat shields wet rags are required to prevent damage.
- When the fan coil unit is in operation components are rotating at high speeds.
- Units must be installed level to ensure proper drainage and operation. These fan coils have a pitched drain pan for improved condensate drainage.
- Check unit prior to operation to ensure that the condensate water will drain towards the drain connection. An overflow drain or an auxiliary drain

pan under the fan coil may be required as a backup to a clogged primary drain pan.

- Check the filter media installation to ensure that it is installed correctly. Use the directional arrows or other information on the filter to determine the proper flow direction.
- Ensure air distribution system does NOT exceed the external static rating of the unit.



IMPORTANT



**SHIPPING BRACKET
REMOVE BEFORE INSTALLATION.**



IMPORTANT



This unit is a **PARTIAL UNIT AIR CONDITIONER**, complying with **PARTIAL UNIT** requirements of this Standard, and must only be connected to other units that have been confirmed as complying to the corresponding **PARTIAL UNIT** requirements of this Standard, **UL 60335-2-40/CSA C22.2 No. 60335-2-40**, or **UL 1995/CSA C22.2 No.236**.



WARNING



Do NOT use means to accelerate the defrosting process or to clean, other than those recommended by the manufacturer.

The appliance shall be stored in a room without continuously operating ignition sources (for example: open flames, an operating gas appliance or an operating electric heater).

Do NOT pierce or burn.

Be aware that refrigerants may not contain an odor.

INSTALLATION

PRECAUTIONS (continued)



WARNING



Do NOT exceed the maximum operating pressure or temperature listed on the unit's rating label.

UNITS WITHOUT PUMPS:

Water Pressure: Max 400 PSIG (2758 kPa)
Min 10 PSIG (69 kPa)

Water Temperature: Max 180°F (82°C)
Min 40°F (4°C)

UNITS WITH PUMPS:

Water Pressure: Max 125 PSIG (862 kPa)
Min 2 PSIG (14 kPa)

Water Temperature: Max 180°F (82°C)
Min 40°F (4°C)

Insulation is installed in indoor equipment to provide a barrier between outside air conditions surrounding the unit and the varying conditions inside the unit. If the insulating barrier is damaged, the surrounding ambient air will affect the inside surface temperature of the cabinet. The temperature/humidity difference between the inside and outside can cause condensation to form on the inside and outside of the cabinet which leads to sheet metal corrosion and subsequently component failure.

Damaged insulation must be repaired or replaced before the unit is placed back into operation. Insulation loses its insulation value when wet, damaged, separated, or torn.

LOCATION & CLEARANCE

Select a location that provides sufficient space for mounting and allows for ducting connections. Maintain a recommended clearance of 24 in. on all sides of the unit for service access. Units may be installed with "0" clearance to combustible materials. Always verify the specific clearance requirements on the unit's rating plate before installation. Refer to the dimensional data in **Figure 2 - Uncased Version** and **Figure 3 - Cased Version (Enclosure)** to determine the space required for mounting CD* units and enclosures.

For installations in areas that may lead to physical damage (e.g., a garage), it is recommended to install a protective barrier to shield the unit. Ensure the unit is installed with a positive slope in the condensate line of 1/4 in. per foot to allow for proper drainage.

All joints made during installation between parts of the refrigerating system must remain accessible for maintenance purposes. Consult all applicable regulatory codes and guidelines prior to determining final clearances and completing the installation.

GENERAL

CD*units are ceiling mounted fan-coil units comprised of a blower assembly, hydronic coil, and a direct expansion coil. Connect the direct expansion coil to a properly matched air conditioning or heat pump unit using R-454B refrigerant only. Do NOT exceed 180°F water temperature in the hydronic coil.

If the fan coil to be connected to an outdoor unit which is charged with an A2L refrigerant a refrigerant sensor must be installed and properly connected to the unit.

Consult local building codes and current editions of the National Electrical Code (NEC) NFPA 70. In Canada, refer to current editions of the Canadian electrical code CSA CEC22.1.

The manufacturer does NOT warrant equipment subjected to abuse. Metal chips, dust, drywall tape, paint overspray, etc. can void warranties and liability for equipment failure, personal injury, and property damage.

The manufacturer assumes no responsibility for equipment installed in violation of any code requirement.

These instructions give information for installation of CD*-HW fan coil units only. For other related equipment, refer to the manufacturers' instructions.

Material in this shipment has been inspected at the factory and released to the transportation agency in good condition. When received, a visual inspection of all cartons should be made immediately. Any evidence of rough handling or apparent damage should be noted on the delivery receipt and the material inspected in the presence of the carrier's representative. If damage is found, a claim should be filed against the carrier immediately.

FAN COIL UNIT

This unit may be installed at altitudes up to 10,000 ft. (3,048 m).

The installer must adhere strictly to all local and national code requirements pertaining to the installation of this equipment. These units are designed for installation in a horizontal position above a dropped ceiling.



CAUTION



Unit must NOT be operated in any mode during building construction due to excessive airborne dust and debris. Also, the unit must never run under any circumstances without an air filter in place.



WARNING



Extreme caution must be taken that no internal damage will result if screws or holes are drilled into the cabinet.

The unit is designed for free return installation (non-ducted return air); therefore, the furred down area must be completely sealed (except return air louver) ensure that all return air is pulled from the conditioned space and NOT from other areas of the building structure.

When installing in close proximity to a room containing a shower, laundry room or other area which is prone to extreme humidity; return air must NOT be taken from these areas. Do NOT use a free return when the unit is installed in an extremely humid area of the conditioned space. Seal the return air duct to the unit and locate the return air louver(s) in a common area communicating with the supply-air duct system.



NOTE



Locate the unit in an area that easily provides minimum clearance to all service access panels. Consider all additional clearances needed for water connections, electrical connections, duct connections, and sufficient return airflow.

FAN COIL UNIT (continued)



WARNING



Refer to equipment rating plates for listed maximum operating pressure, Do NOT exceed this pressure.



IMPORTANT



Electrical work associated with the installation of this appliance must comply with the National Electrical Code (NEC).

Access must be provided for servicing the unit. If this access is provided by a removal of the blower panels and to provide access to electrical and plumbing controls. While most fan coils are approved for installations with zero clearance to combustible materials, reference should be made to the marking on the particular unit being installed where specific information regarding clearances is provided

AIR DISTRIBUTION DUCTS

All duct work must be installed in accordance with National Fire Protection Association Codes 90A and 90B. Ducts should be adequately insulated to prevent condensation during the cooling cycle. All return air must be filtered to prevent dirt buildup on the coil surface. If there is no ducted return, applicable installation codes may limit the unit to installation only in a single-story residence. In many cases it is acceptable to use ducting of the same size as the fan coil connections however, unique arrangements or long duct runs must be confirmed by a local professional. The manufacturer will NOT be responsible for misapplied equipment.

All units are safety agency listed (see unit label) for installation with zero inches clearance to combustible materials. This includes the unit cabinet, discharge plenum and connecting ducts.

STATIC PRESSURE

These fan coil units are designed for quiet operation; however, all air conditioning equipment will transfer some amount of noise to the conditioned space. This should be taken into consideration when planning the location of equipment and design of the ducts.

The total external static pressure must be considered.

These fan coil units are designed for quiet operation; however, all air conditioning equipment will transfer some amount of noise to the conditioned space. This should be taken into consideration when planning the location of equipment and design of the ducts.

The total external static pressure must be considered when planning installation and duct design. Refer to the rating label the unit for more information. Units with PSC motors are recommended for use up to .3 in. wc. (75 Pa) total external static pressure. Units with ECM motors are recommended for use up to .5 in. wc (125Pa) total external static. A unit operating at lower total external static pressure will be more efficient and quieter vs. operation at higher static pressure.

MAINTAINING LOW SIR LEAKAGE RATE

During installation, ensure that all grommets and gaskets remain intact on all surfaces as shipped with the unit. Any knockouts, penetrations, and holes that were exposed must be sealed to prevent air leakage. All access panels and covers must be flush with each other and the cabinet. With these requirement satisfied, the unit will maintain and achieves less than 2% air flow leakage when tested in accordance with ASHARE Standard 193.

DIMENSIONS

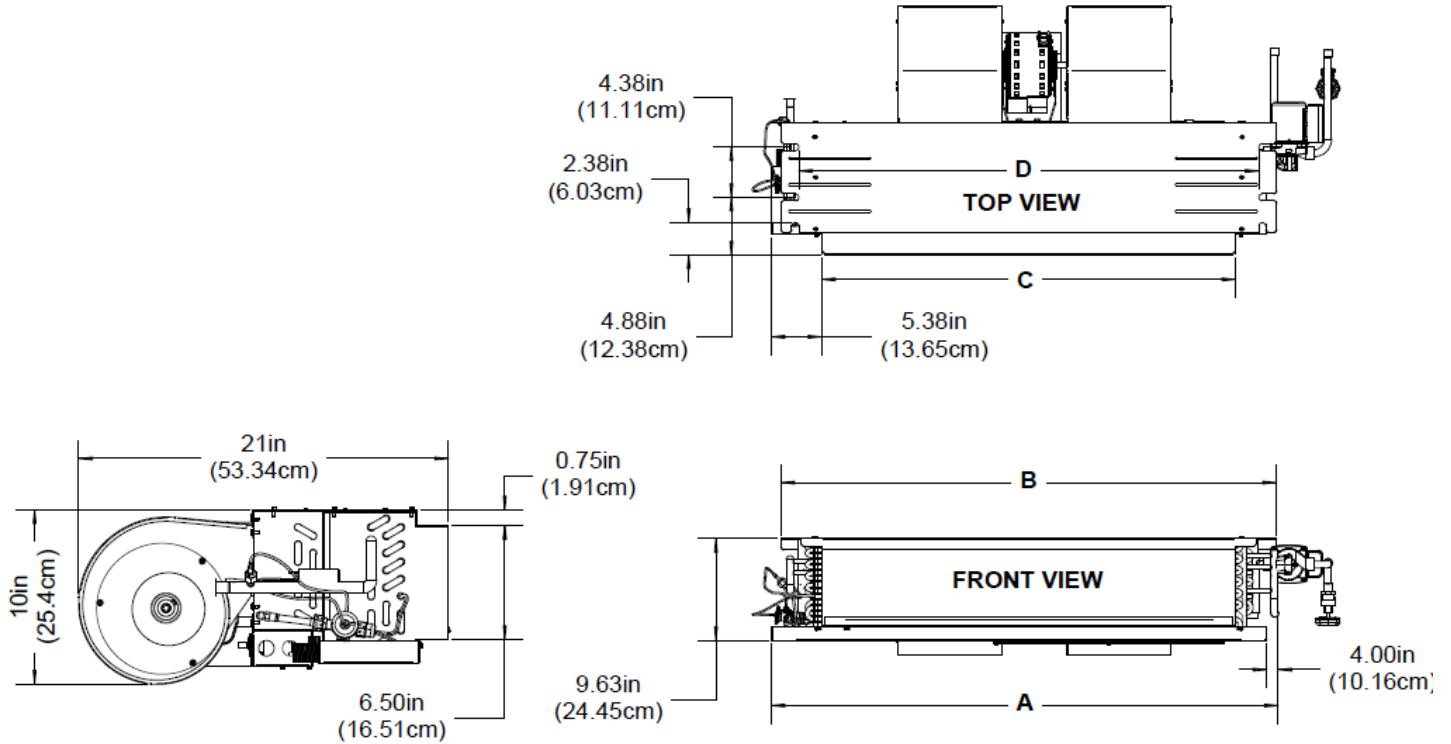

Figure 2 - Uncased Version

*Uncased Unit with Pump Dimensions in. (cm)

Model	A	B	C	D
12, 18, 19CD*Q*	45.13 (114.6)	37.25 (94.6)	30.13 (76.5)	34.75 (88.3)
20, 25CD*Q*	51.13 (129.9)	43.25 (109.9)	36.13 (91.8)	40.75 (103.5)
26, 31CD*Q*	57.13 (145.1)	49.25 (125.1)	42.13 (107)	46.75 (118.7)
32, 37CD*Q*	64.13 (162.9)	56.25 (142.9)	49.13 (124.8)	53.75 (136.5)

TABLE 1 - *UNCASED UNIT WITH PUMP DIMENSIONS

*Dimensions shown are for unit only. Room for refrigerant tubing, electrical, and drain piping must be considered along with adequate service clearance when planning the installation.

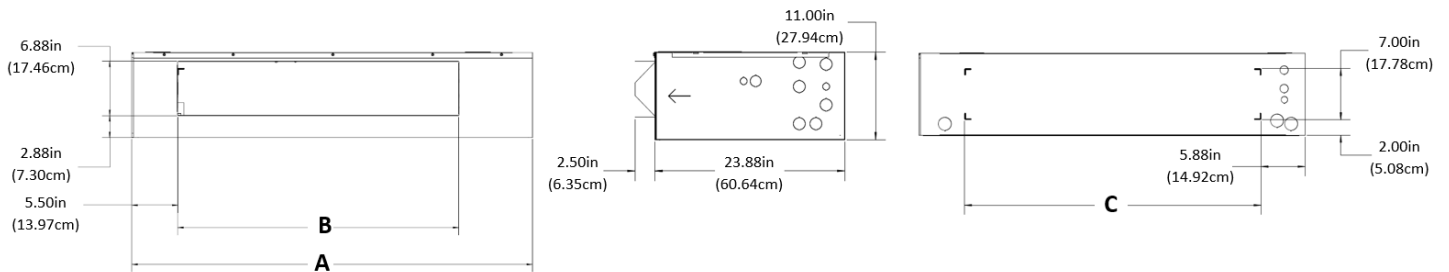

Figure 3 - Cased Version (Enclosure)

Enclosure Dimensions in. (cm)

Model	Enclosure No.	A	B	C
12, 19CD*	9ECDX01	45.75 (116.2)	30.88 (78.4)	34.00 (86.4)
20, 25CD*	9ECDX02	51.75 (131.4)	36.88 (93.7)	40.00 (101.6)
26, 31CD*	9ECDX03	58.50 (148.6)	42.88 (108.9)	46.75 (118.7)
32, 37CD*	9ECDX04	66.50 (168.9)	49.88 (126.7)	54.75 (139)

TABLE 2 - ENCLOSURE DIMENSIONS

*Dimensions shown are for unit only. Room for refrigerant tubing, electrical, and drain piping must be considered along with adequate service clearance when planning the installation.

ELECTRICAL

WARNING

ELECTRIC SHOCK HAZARD

To avoid the risk of fire or equipment damage, use only copper conductors.

Disconnect all power before servicing or installing this unit. Multiple power sources maybe present. The electrical power to this unit must be in the off position and all power supplies disconnected. Failure to do so may cause property damage, personal injury, or death.

WARNING

The unit cabinet must have an uninterrupted and unbroken ground to minimize personal injury if an electrical fault should occur. Provide ground circuit in accordance with all applicable national and local codes.

Electrical work associated with the installation of this appliance must comply with the National Electrical Code (NEC). Other local or regional electrical and building code requirements may apply.

In Canada electrical work associated with the installation of this appliance must comply with CE CSA C22.1.

Units are provided with wiring diagrams and nameplate data to provide information required for necessary field wiring. An enclosed terminal strip or wires are provided on the left side of the unit (looking at the blower) for the connection of line voltage supply conductors. Refer to your unit wiring diagram.

WARNING

Any devices such as fan switches or thermostats that have been furnished by the factory for field installation must be wired in strict accordance with the wiring diagram that is supplied with the unit. Failure to do so could result in damage to components and will void all warranties.

WARNING

Some transformers are multi-voltage; it is crucial to refer to unit wiring diagram as well as unit voltage to ensure proper connections and operation safety.

These units are provided with a Class 2 transformer for 24-volt control circuits. Should any add-on equipment also have a Class 2 transformer furnished, care must be taken to prevent interconnecting outputs of the two transformers by using a thermostat with isolating contacts.

OVER CURRENT PROTECTION

HACR type breakers are recommended. Other over-current protection devices that comply with all applicable codes are acceptable.

Field installed electrical wiring supplying power to this unit and/or electrical heaters must include a disconnect device at the unit.

OPERATING VOLTAGE

115 or 120 Volt CDX* fan-coil units are factory wired for nominal 120-volt supply.

208/240 Volt CDX* fan coil units are factory wired for a 240V supply. Follow the steps below to change the transformer primary wire connections at the time of installation when a 208V power supply is used.

208 VOLT OPERATION

1. Disconnect and lockout all power supplies to the fan coil unit.
2. Disconnect the orange primary transformer wire from its connection point.
3. Connect the blue primary transformer wire to original connection point of orange wire.
4. Cap-off the orange primary transformer wire.

WARNING

ELECTRIC SHOCK HAZARD

Means of disconnection must be incorporated in the fixed wiring in accordance with the wiring rules.

THERMOSTAT WIRING

The unit provides 24 VAC pig-tail wires to connect a 24-VAC thermostat. This is located on the right side of the unit. (looking at the blower) See low voltage detail on wire diagram.

ELECTRICAL (continued)

Use 18 AWG wire with color-coded insulation (35°C minimum) up to 100 ft. in length (31 m). Use 16 AWG wire if more than 100 ft. of wire is required.

Refer to latest edition of the National Electric Code or in Canada the Canadian Electric Code when determining the correct wire size.

The direct expansion cooling coil in CD* units are factory equipped with freeze protection. A freeze protection thermostat is mounted on the coil and is wired in series

with the contactor of the outdoor unit. Please note the wiring detail of this circuit below. The two gray sensor wires must be connected to field installed control wiring as shown.

⚠	WARNING	⚠
⚡	ELECTRIC SHOCK HAZARD	⚡
Means of disconnection must be incorporated in the fixed wiring in accordance with the wiring rules.		

DX COIL SENSOR WIRING (Only DX coil sensor connections shown)

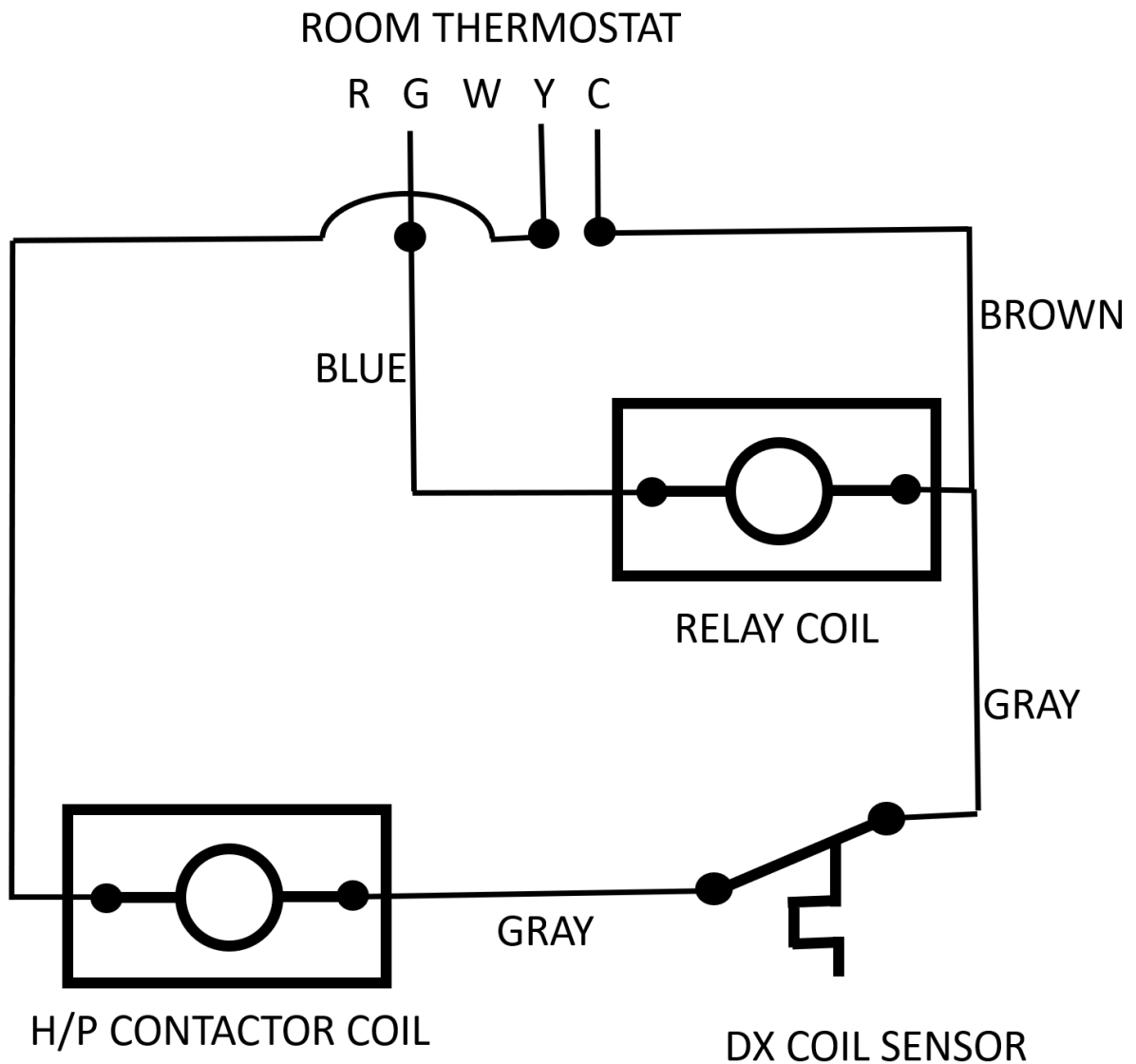

Figure 4 - Coil Sensor Connection

WIRING DIAGRAMS

MODEL	NOM. COOLING CAPACITY	M2	M1	OPTIONAL HIGH
12 CDXQX	12,000	**YELLOW**	**ORANGE**	GREEN
19/20 CDXQX	18,000	**YELLOW**	**ORANGE**	GREEN
25/26 CDXQX	24,000	**ORANGE**	**GREEN**	WHITE
	18,000	YELLOW	ORANGE	GREEN
31/32 CDXQX	30,000	**ORANGE**	**GREEN**	WHITE
	24,000	YELLOW	ORANGE	GREEN
37 CDXQX	36,000	**ORANGE**	**GREEN**	WHITE
	30,000	YELLOW	ORANGE	GREEN

** INDICATES FACTORY PRESET WIRING

NOTE: TERMINALS SUITABLE FOR COPPER CONDUCTORS ONLY

REMARQUE: UTILISER DES FILS D'ALIMENTATION EN CUIVRE

CDXQX
WD46X001
Rev L
01/25

CLASS III CONSTRUCTION
 READ THE INSTRUCTIONS

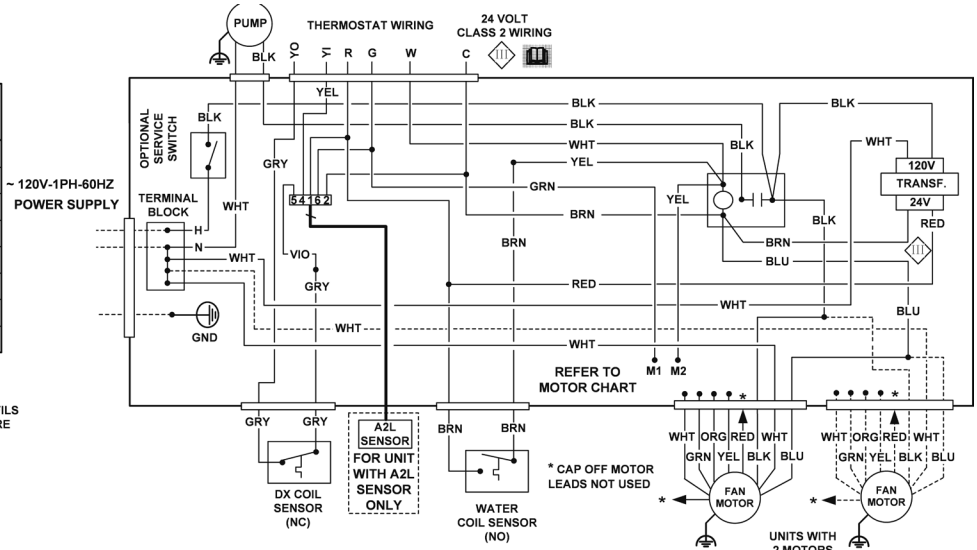

Figure 5 – WD46X001, CD*QX w/ ECM Motor 120V

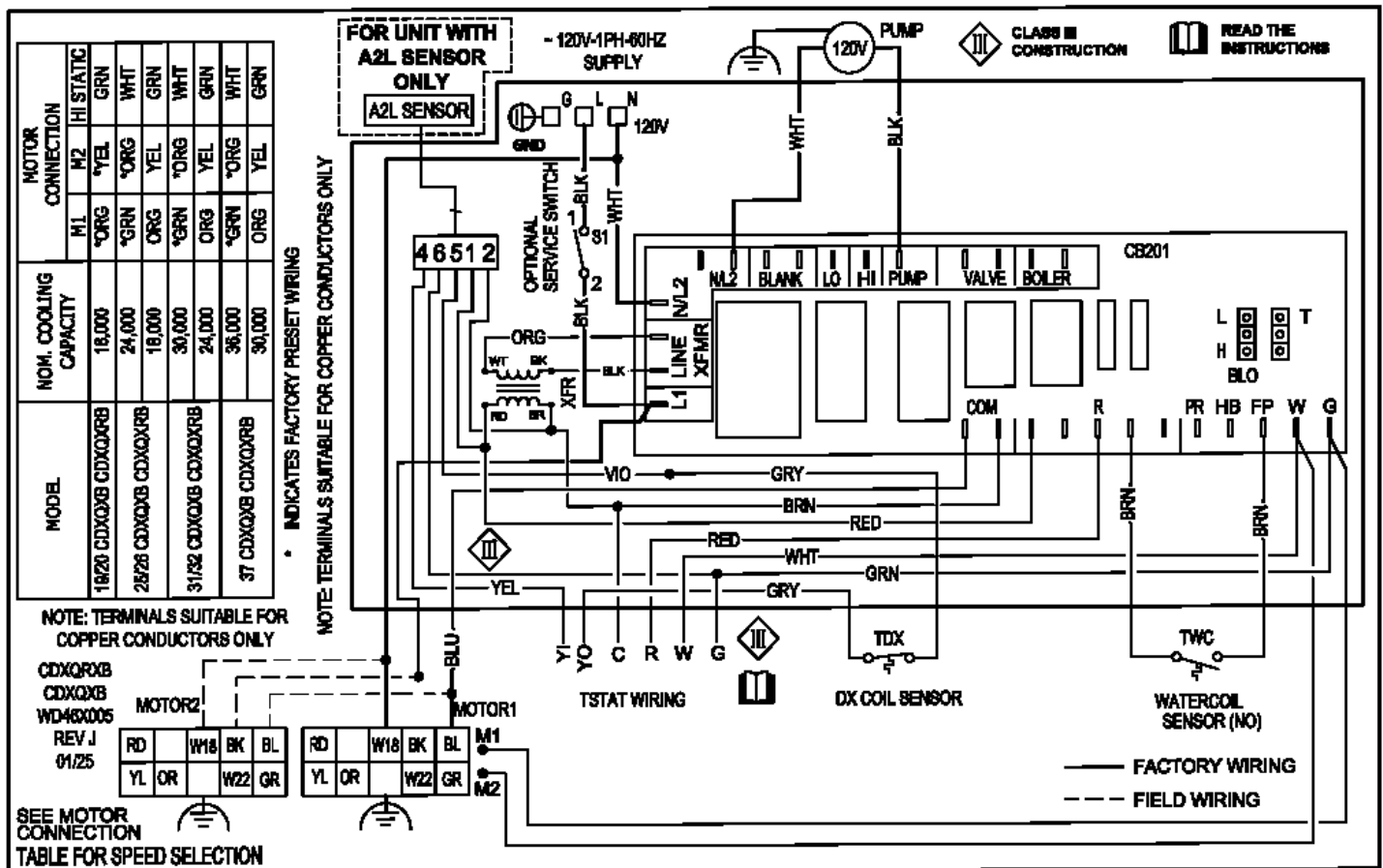

Figure 6 – WD46X005, CD*QRXB/CD*QXB Board 120V

WIRING DIAGRAMS (continued)

MODEL	NOM. COOLING CAPACITY	MOTOR LEAD	
		M1	M2
18/19/20 CDXQ	18,000	**BLACK**	**BLUE**
24/26 CDXQ	24,000	**BLACK**	**BLUE**
	18,000	BLUE	RED
25 CDXQ	24,000	**BLACK**	**BLUE**
	18,000	RED	RED
30 CDXQ	30,000	**BLACK**	**BLUE**
	24,000	BLUE	RED
31 CDXQ	30,000	**BLACK**	**BLUE**
	24,000	RED	RED
32 CDXQ	30,000	**BLUE**	**RED**
	24,000	RED	RED
36/37 CDXQ	36,000	**BLACK**	**BLUE**
	30,000	BLUE	RED

**INDICATES FACTORY PRESET WIRING

CLASS III CONSTRUCTION

READ THE INSTRUCTIONS

REMARQUE: UTILISER DES FILS D'ALIMENTATION EN CUIVRE

NOTE: TERMINALS SUITABLE FOR COPPER CONDUCTORS ONLY

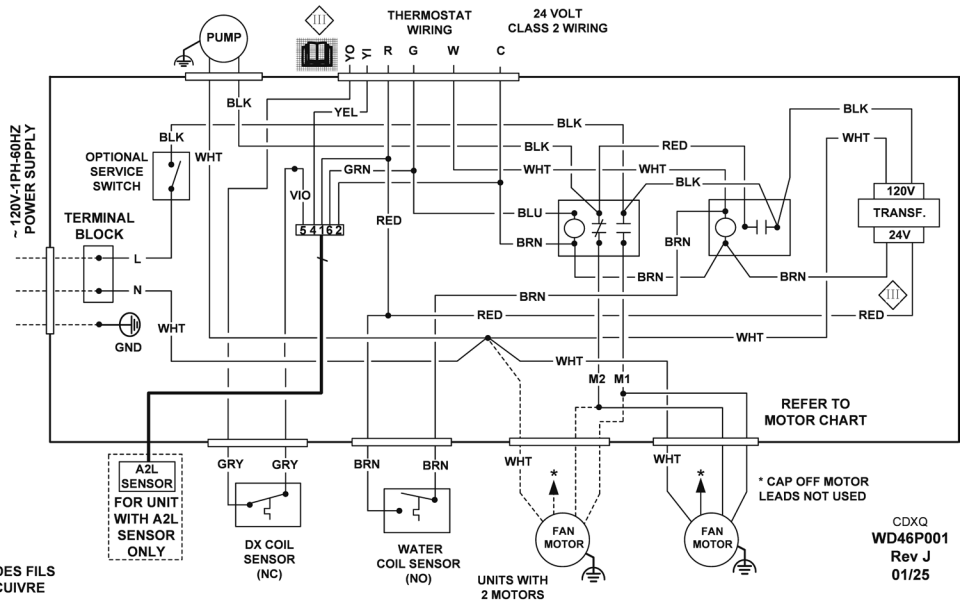

CDXQ
WD46P001
Rev J
01/25

Figure 7 – WD46P001, CD*Q 120V

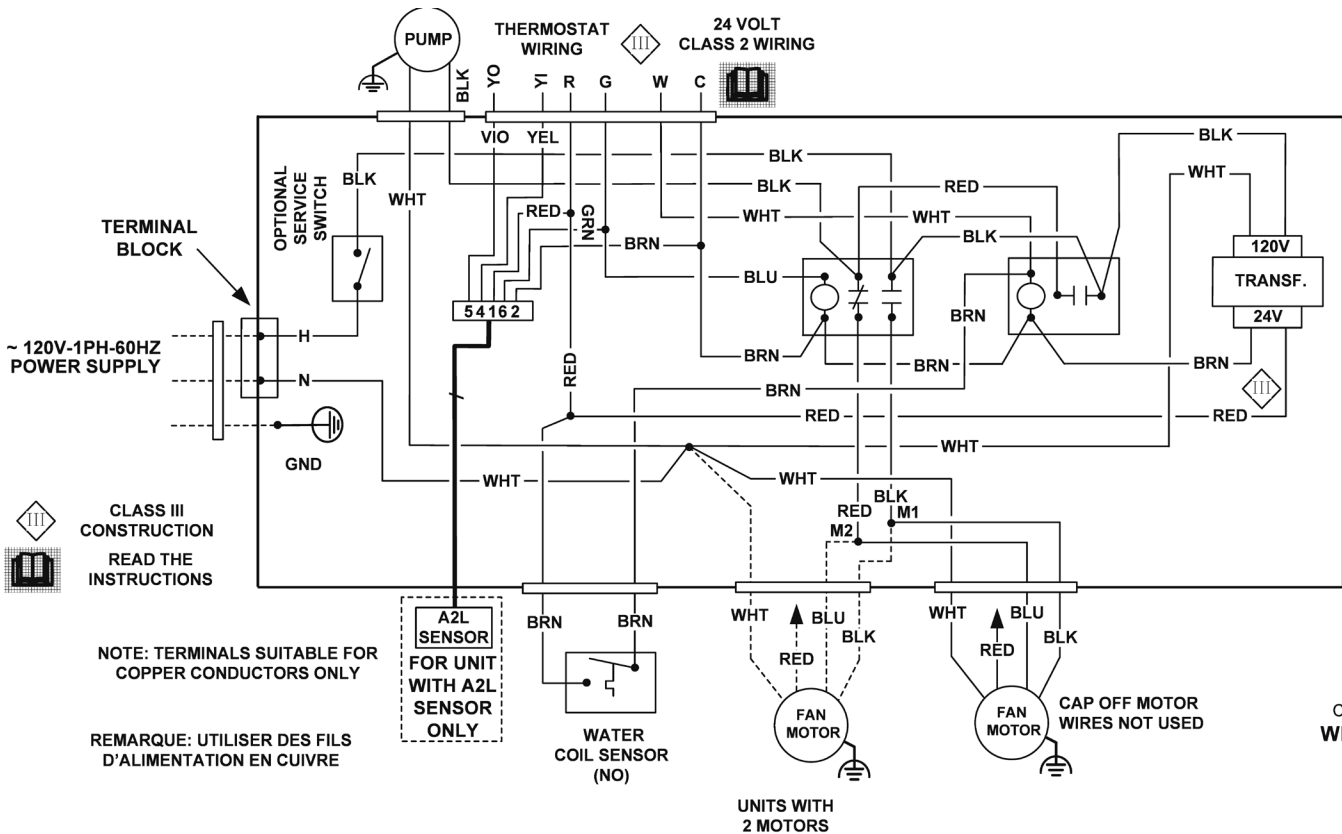

CDXQ-HO
WD46P003
Rev I
01/25

Figure 8 – WD46P003, CD*Q - HO, Ht. Only 120V

WIRING DIAGRAMS (continued)

MODEL	NOM. COOLING CAPACITY	MOTOR LEAD	
		M1	M2
18/19/20 CDXQR	18,000	**BLACK**	**BLUE**
24/26 CDXQR	24,000	**BLACK**	**BLUE**
	18,000	BLUE	RED
25 CDXQR	24,000	**BLACK**	**BLUE**
	18,000	RED	RED
30 CDXQR	30,000	**BLACK**	**BLUE**
	24,000	BLUE	RED
31 CDXQR	30,000	**BLACK**	**BLUE**
	24,000	RED	RED
32 CDXQR	30,000	**BLUE**	**RED**
	24,000	RED	RED
36/37 CDXQR	36,000	**BLACK**	**BLUE**
	30,000	BLUE	RED

* CONNECT ANY UNUSED MOTOR LEADS TO THE CONNECTION LABELED "BLANK" ON THE CONTROL BOARD
 ** INDICATES FACTORY PRESET WIRING

NOTE: TERMINALS SUITABLE FOR COPPER CONDUCTORS ONLY

REMARQUE: UTILISER DES FILS D'ALIMENTATION EN CUIVRE

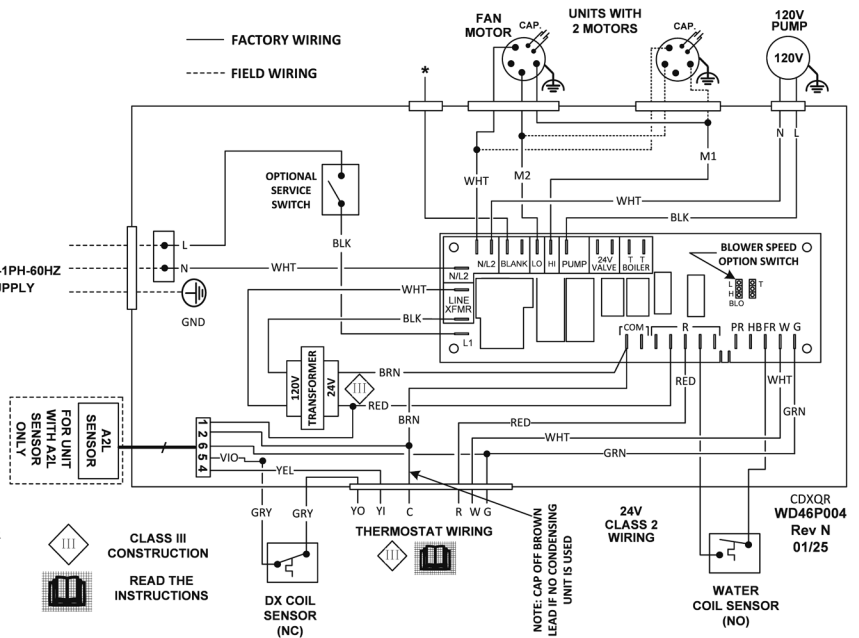

Figure 9 – WD46P004, CD*QR, Board 120V

HOT WATER COIL PIPING PRECAUTIONS

PIPING PRECAUTIONS

! WARNING !

Do NOT exceed 400 PSIG (2758 kPa) pressure in the water coil

1. Flush all field piping prior to connection to remove all debris.
2. Use wet cotton rags to cool valve bodies when soldering.
3. Open all valves (mid-way for hand valves, manually open on motorized valves) prior to soldering.
4. When soldering to bronze or brass, heat the piping while in the socket/cup and begin introducing the solder when the flux boils rapidly. Avoid direct flame into the solder joint.
5. Heat can only be applied to the cup of the valve body for a minimal time before damage occurs (even with use of wet rags).
6. Avoid rapid quenching of solder joints as this will produce joints of inferior quality.
7. Provisions must be made for expansion and contraction of piping systems. All horizontal and vertical risers, including runouts, must be able to withstand significant movement with temperature changes. Failure to do so will result in damage and failure of piping, fittings, and valves throughout the building.

8. All piping made in the field should be installed with consideration of additional space for any electrical routing that may be required.
9. Connect all piping per accepted industry standards and observe all regulations governing installation of piping systems.

! CAUTION !

Hydronic systems are NOT designed to hold pressurized air and should only be tested with water. Pressurizing system with air could damage equipment.

10. When all connections are complete, pressure test system. Repair any solder joint leaks and gently tighten any leaking valve packing nuts and piping accessories, as required.

i NOTE i

Hot water represents a serious safety hazard due to potential scalding. The temperature of water normally required to provide space heating (135-140°F.) may be hotter than certain codes allow for domestic hot water. An "antscald valve" can be installed in the hot water piping that would allow the domestic water to be supplied at a lower temperature than the space heating water. These can be obtained locally and should be installed according to the manufacturer's installation instructions.

HOT WATER COIL PIPING INSTALLATION

Refer to the Flow Control Module installation instructions for proper pump installation, if used.

CAUTION

When connecting piping to fan coil units, do NOT bend or reposition the coil header tubing for alignment purposes. This could cause a tubing fracture resulting in a water leak when pressure is applied to the system.

WARNING

An expansion tank may be required if a back-flow preventer is installed in the system.

CD*Q*/CD*QX – FOR TANK WATER HEATER – W/ 006 CIRCULATOR

All piping between the water heater and fan coil unit should be 3/4 in. nominal (7/8 in. O.D.) copper pipe to prevent excessive head pressure loss. Refer to **Table 3 – Tank Water Heater** for available pressure drop vs GPM. The installer must calculate all piping pressure drop within the water loop and size the pipe and overall length accordingly.

Tank Water Heater		
Model	GPM	PD (Ft. Wtr.) Available
19CD*Q*	2.5	4.0
	3.0	3.5
20/25CD*Q*	2.5	3.6
	3.0	2.7
26/31CD*Q*	2.5	3.4
	3.0	2.5
32/37CD*Q*	2.5	2.8
	3.0	1.4

TABLE 3 - TANK WATER HEATER

CD*QR / CD*QXR – FOR TANKLESS WATER HEATER – W/ 008 CIRCULATOR

For tankless applications, refer to tankless manufacturer’s specifications on system piping requirements and flow requirements. Refer to table below for available pressure drop vs GPM. The installer must calculate all piping pressure drop within the water loop and size the pipe and overall length accordingly. Refer to labels provide on equipment piping for correct supply and return connections.

Tankless Water Heater		
Model	GPM	PD (Ft. Wtr.) Available
19CD*QR	2.5	4.0
	3.0	3.5
20/25CD*QR	2.5	3.6
	3.0	2.7
26/31CD*QR	2.5	3.4
	3.0	2.5
32/37CD*QR	2.5	2.8
	3.0	1.4

TABLE 4 - TANKLESS WATER HEATER

It is also recommended that all piping be adequately insulated to prevent freezing when piping is run in an unconditioned space.

NOTE

The *CD*Q fan coil unit comes with a hot water coil freeze protector. This device may NOT sufficiently protect the water lines if the fan coil is located in ambient air locations (attics, crawl spaces, etc.) or within structures that may be unoccupied during freezing conditions. Consult the factory for additional information.

Solder Connections – All copper joints in the water lines must be made with low temperature – non lead solder.

“T” Connections (at the water heater) – water lines to and from the fan coil unit must be taken from the horizontal connection of the “T” fittings in the vertical hot and cold water supply lines at the water heater. This ensures that any air in the system will be purged each time water is used in the dwelling. Refer to **Figure 10 - Recommended P-Trap**.

Isolation Valves – Two valves are recommended to be installed within the circulating loop to permit servicing of the system if required and to assist in purging the system.

COOLING COIL PIPING

The *CD*Q fan coil units are supplied with a direct expansion refrigerant coil. The refrigerant metering device is either a fixed orifice piston or Bi-Directional TXV and is installed at the factory. This permits the unit to be matched with either a standard condensing unit or heat pump. The suction and liquid refrigerant lines must be sized in accordance with the outdoor unit manufacturer's recommendations.

REFRIGERANT CHARGING

Use adequate personal protection equipment when handling refrigerant including, but not limited to eye and hand protection. **USE ONLY R-454B refrigerant.** Consult the outdoor unit manufacturer's instructions for refrigerant charging and consider all pertinent factors when determining the method of charging and the amount of refrigerant required; indoor and outdoor temperatures and humidity, the factory charge amount of the outdoor unit, the length and diameter of tubing between the indoor and outdoor units, the type of metering device installed.

PARTIAL SYSTEM CHARGING

Follow the outdoor unit manufacturer's instructions for adding refrigerant to a partially charged system.

CONDENSING PIPING

Condensate drain lines must be installed with adequate slope away from the unit to assure positive drainage. Since the drain pan is located on the suction side of the blower, a negative pressure exists at the drain pan and a minimum trap of 1.5 in. (3.8 cm) should be provided in the drain line to assure proper drainage. The fan coil unit may be located where the return air space is large enough that a negative pressure is not present, however, a trapped condensate line is recommended in case a negative condition should occur, the unit would drain properly.

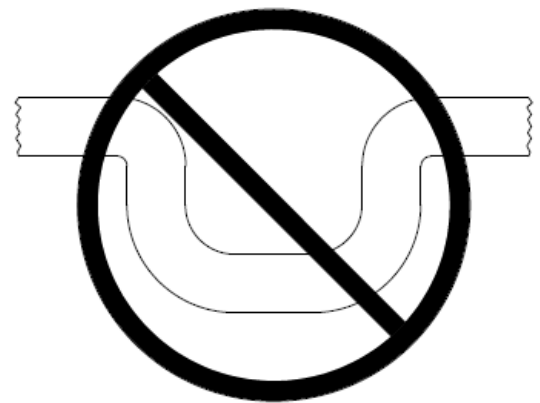
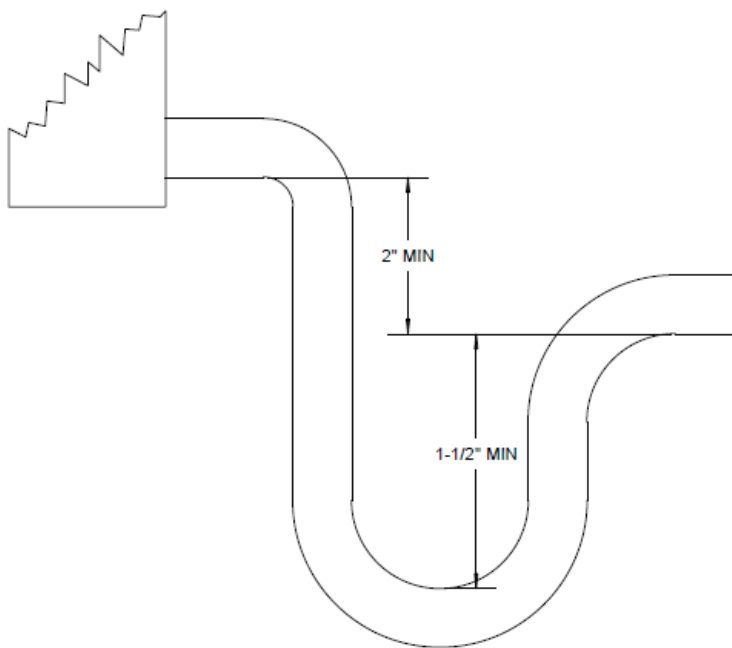

DO NOT USE SHALLOW RUNNING TRAPS!

Figure 10 - Recommended P-Trap

PRE-STARTUP CHECKS

WARNING

ELECTRIC SHOCK HAZARD

Electrically ground fan coil. Connect ground wire to ground terminal marked "GND". Failure to do so can result in injury or death.

Do NOT touch any rotating component with any object. Damage to the equipment and personal injury can occur.

CAUTION

Any device such as a fan switch or thermostat that has been furnished by the factory for field installation must be wired in strict accordance with the wiring diagram that is supplied with the unit. Failure to do so could result in damage to components and will void all warranties.

WARNING

ELECTRIC SHOCK HAZARD

Transformers are multi voltage, it is crucial to refer to unit wiring diagram, transformers wiring diagram as well as unit voltage to ensure proper connections and operation safety.

Before start-up, all of the components should be given a thorough check. Optimal operation of this equipment requires cleanliness. Often after installation of this equipment additional construction activities occur. Care must be taken to protect the equipment from debris during these construction phases.

Prior to starting the unit:

1. Ensure supply voltage matches nameplate data.
2. Ensure unit is properly grounded.
3. With power off, check blower wheel set-screws for tightness and ensure blower wheels rotate freely and quietly.
4. Ensure fan coil is properly and securely installed.
5. Ensure unit is sloped toward drain line.
6. Ensure unit will be accessible for servicing.
7. Ensure condensate line is properly sized, run, trapped, pitched, and tested.
8. Ensure all cabinet openings and wiring connections have been sealed.
9. Ensure all access panels are in place and of adequate size.
10. Ensure all access panels are in place and secured.
11. Check that the refrigerant coil connections and piping have been leak checked and insulated as required.
12. Check that the water coil, valves, and piping have been leak checked and insulated as required.
13. Ensure that all air has been vented from the hot water loop.

NOTE

It may require purging several gallons of water so have a means of discarding the water.

MAINTAINING LOW AIR LEAKAGE RATE

During installation, ensure that all grommets and gaskets remain intact on all surfaces as shipped with the unit. Any knockouts, penetrations, and holes that were exposed must be sealed to prevent air leakage. All access panels and covers must be flushed with each other and the cabinet. With these requirements satisfied, the unit will maintain and achieve less than 2% airflow leakage when tested in accordance with ASHRAE standard 193.

HEATING CYCLE START-UP

Fill the water heater. Open a hot water faucet while filling the water heater to vent the air. When the tank is full and all the air is purged, close the faucet.

1. Ignite the water heater and set the thermostat to 140°F (60°C).
2. Purge the air handler's hot water coil and lines.



NOTE



It may require purging several gallons of water so either have a bucket available or a means of discarding the water.

3. Switch the room thermostat to the "Heat" position and raise the temperature setting to a position approximately ten degrees above room temperature.



WARNING



To prevent damage, the fan coil unit should NOT be energized for heating until the hot water coil and all the water lines have been purged of air. The pump should energize and begin circulating the hot water through the coil. If the pump is operating properly and the water temperature in the water heater has reached the set point, then the hot water inlet at the fan coil unit will be hot. If the pump is running but hot water is NOT circulating, open the air bleed valve long enough to purge any remaining air from the hot water lines and coil. This will allow the pump to begin circulating hot water.

4. The water heater thermostat should be adjusted so that the water temperature entering the hot water coil is as close to 140°F (60°C) as possible with the system energized and operating long enough for all temperature to stabilize.

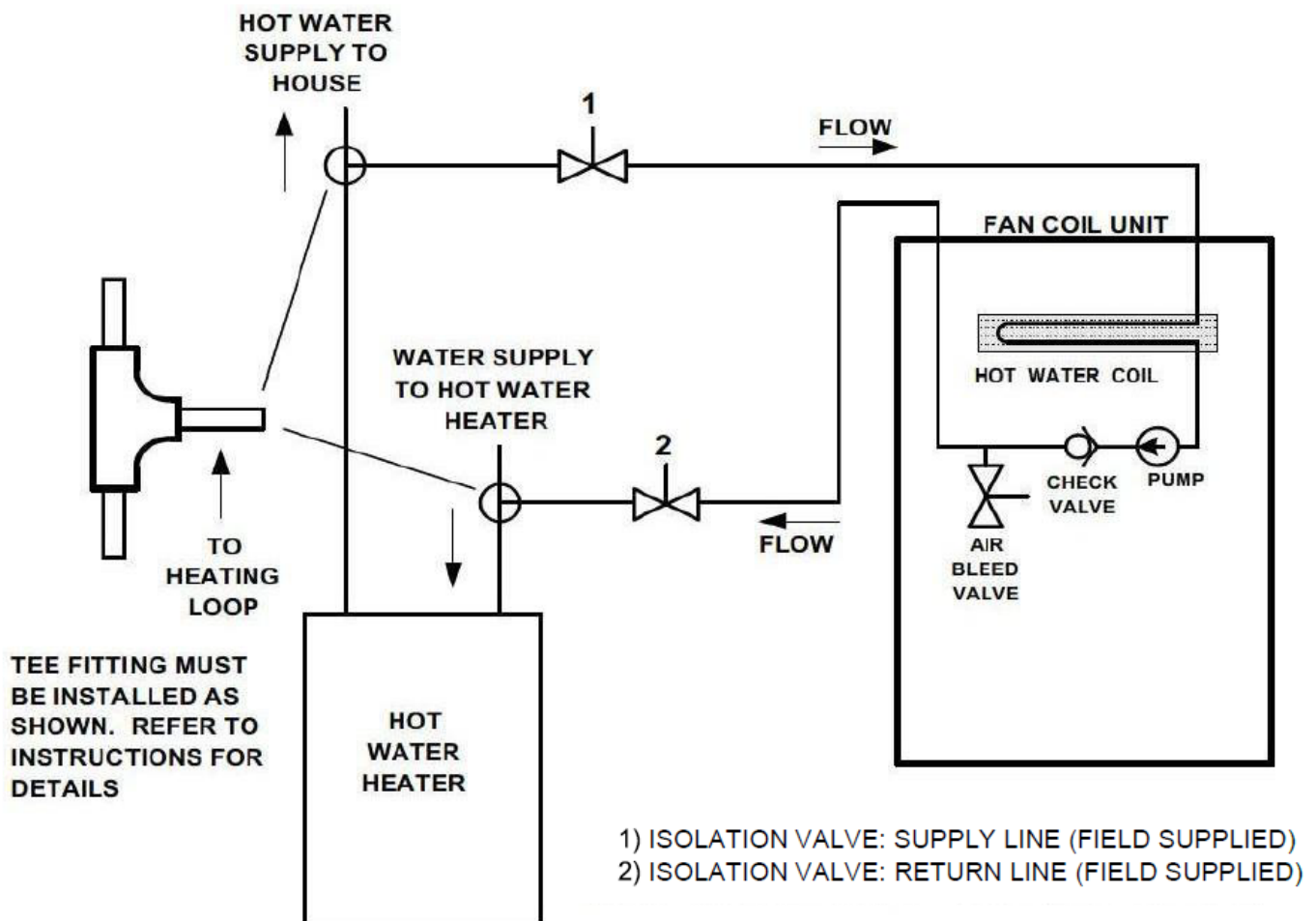

Figure 11 - Typical Piping Schematic

MOUNTING

The fan coil unit must be installed to ensure they are securely fixed and remain stable in position throughout their operation. The mounting structure must be capable of safely supporting the full weight of the equipment under all conditions. Use anchors that are appropriately sized and securely fastened to provide a safe and durable installation.

These units are equipped with four (4) mounting slots to facilitate secure attachment. Installers must use metal washers and nuts of the proper size, ensuring all connections are tight and stable. If mounting to wooden joists, use a minimum of 1/4 in. by 2 in. wood screws fully engaged with fender washers to secure to the unit the structure. If the mounting surface is uneven, shims must be used to achieve proper leveling, ensuring effective condensate drainage. Refer to **Figure 12 - Structure Support with Fasteners** and **Figure 13 - Structure Support Location**.

WARNING

When connecting piping to fan coils, do NOT bend or reposition the coil header tubing for alignment purposes. This could cause a tubing fracture resulting in a refrigerant leak when pressure is applied to the system.

CAUTION

Extreme caution must be exercised to prevent internal damage during installation. Proper leveling and secure mounting will ensure optimal performance and prevent issues such as improper drainage or operational instability. Always consult local building codes and applicable standards during installation.

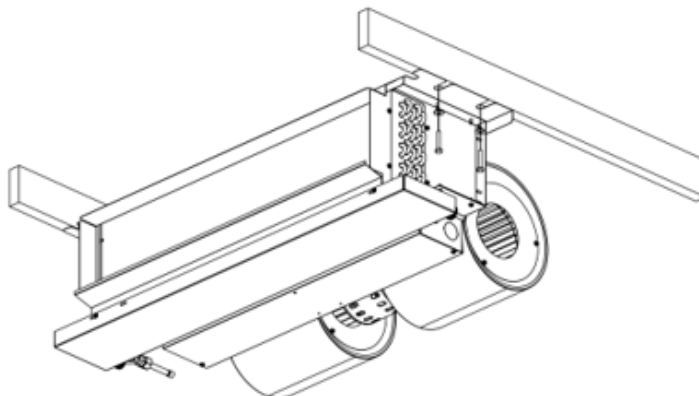

Figure 12 - Structure Support with Fasteners

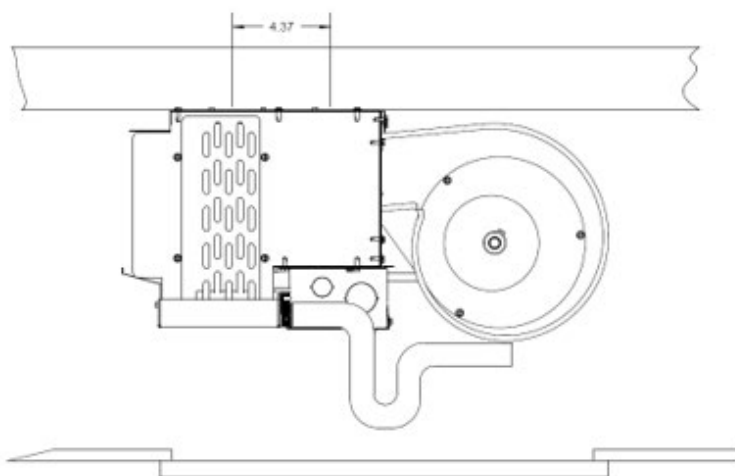





Figure 13 - Structure Support Location

LEAK CHECKS

After pipe installation perform a leak check to ensure that no leakage of refrigerants will occur. Use nitrogen to pressure test at a minimum of 200 PSIG. Pressure must not decrease within 1 hour. Care must be taken to not use any leak detectors which may cause corrosion on the copper tubing.



Evacuate the suction and liquid lines at the outdoor unit service valves to 500 microns. Isolate the vacuum pump from the piping. The vacuum must NOT exceed 1500 microns in 10 minutes.

REFRIGERANT CHARGING

	WARNING	
	FIRE OR EXPLOSION HAZARD	
Failure to following this warning could result in personal injury, death and/or property damage.		
Do NOT use flames or any potential ignition sources to leak check refrigerant tubing or components.		

	IMPORTANT	
Any metering device installed in the refrigerant circuit must be compatible with the refrigerant used.		

Use adequate personal protection equipment when handling refrigerant including, but not limited to eye and hand protection. Consult the outdoor unit manufacturer's instructions for refrigerant charging and consider all pertinent factors when determining the method of charging and the amount of refrigerant required; indoor and outdoor temperatures and humidity, the factory charge amount of the outdoor unit, the length and diameter of tubing between the indoor and outdoor units, the type of metering device installed.

	WARNING	
<u>IMPROPER HANDLING OF REFRIGERANTS CAN CAUSE INJURY, EXPLOSION, AND DEATH</u>		
<ul style="list-style-type: none"> • It is illegal to release refrigerant into the atmosphere. Refrigerant released into an enclosed space will displace oxygen causing unconsciousness and death. • If an indoor refrigerant leak is suspected, thoroughly ventilate the area before beginning any work. • DO NOT purge or allow refrigerant to be released into an interior space. • Contact with liquid refrigerant can cause frostbite and blindness. Avoid skin contact with liquid refrigerant, wear goggles and gloves when working with refrigerants. Seek medical help immediately if any refrigerant contact with skin or eyes occurs. • Never burn refrigerant as highly toxic gas will be produced. 		

REFRIGERANT CHARGING (continued)

WARNING

- Only EPA certified technicians should handle refrigerants.
- In Canada technicians must be ODP/ODS certified to handle refrigerants.
- Follow all EPA regulations.
- Explosion risk, recover refrigerant only in a cylinder designed and intended for this purpose.
- Do NOT use a damaged cylinder.
- Do NOT apply flame or excessive heat to a refrigerant cylinder.
- Do NOT fill a refrigerant cylinder to more than 80% of its capacity.
- Do NOT use a refrigerant cylinder for anything other than its designed and intended purpose.
- Do NOT use an expired refrigerant cylinder.
- Use recovery equipment designed to handle the refrigerant being recovered.
- Earth-ground refrigerant cylinders before using.

- **Leaded Detection Fluids:** Fluids such as the bubble method or fluorescent agents are suitable. Avoid detergents containing chlorine, as these may react with the refrigerant and corrode copper pipework.

Important Note: if a refrigerant leak is suspected, all open flames must be extinguished. For leaks requiring brazing, recover all refrigerant from the system or isolate it using shut-off valves in a remote part of the system. Removal of refrigerant must follow the removal and evacuation procedures.

REFRIGERANT CHARGING INSTRUCTIONS

When charging the system in cooling mode, ensure the outdoor temperature is 60°F or higher. Operate the system for a minimum of 25 minutes between adjustments to allow the pressure to stabilize. Systems equipped with micro-channel outdoor coils require small adjustments of 1 oz. or less, as they are highly sensitive to refrigerant charge.

TXV Charging

1. Refer to the instructions provided with the outdoor unit.
2. Alternatively, for AC units, charge to achieve 12°F sub-cooling. For heat pump units, charge to 10°F sub-cooling.
3. If the system is equipped with an adjustable valve, adjust to achieve 10°F superheat.

Fixed Orifice Charging

1. Use the superheat valve recommended in the outdoor unit instructions for A1 (R-410) and A2L (R-454B & R-32) refrigerants.
2. Heat pump units initially charged in cooling mode may require final charge adjustments in heating mode, if necessary. For units requiring charging in heating mode.

If the system is undercharged after the initial charge, add refrigerant until the sight glass is clear and the recommended pressures, temperatures, subcooling, and superheat are achieved. If the system is overcharged, recover refrigerant until these values are within recommended limits.

WARNING

It is illegal to discharge refrigerant into the atmosphere. Use proper reclaiming methods and equipment when installing or servicing this unit. A QUALIFIED service agency should perform this service.

Follow the outdoor unit manufacturer's instructions for adding refrigerant to a partially charged system.

FLAMMABLE REFRIGERANT LEAK DETECTION

Under no circumstances should potentially sources of ignition be used for detecting refrigerant leaks. Devices such as halide torches (or other detectors using a naked flame) are strictly prohibited.

Acceptable methods for refrigerant leak detection include:

- **Electronic Leak Detectors:** these may be used to detect refrigerant leaks; however, for flammable refrigerants, ensure the sensitivity is adequate and the equipment is recalibrated as necessary. Calibration must occur in a refrigerant free area. The detector must not pose an ignition risk and should be specifically suited for the refrigerant used. Set the detection equipment to a percentage of the refrigerant's Lower Flammability Limit (LFL), with a maximum setting of 25%. Ensure calibration corresponds to the refrigerant employed.

OPERATION & MAINTENANCE

WARNING

FIRE OR EXPLOSION HAZARD

Failure to following this warning could result in personal injury, death and/or property damage.

Do NOT attempt any sealed system repair without first recovering the entire refrigerant charge. R-454B refrigerant and oil mixture could ignite in the presence of a brazing torch flame. Completely recover the refrigerant charge using both the high and low sides of the system and purge the sealed system with nitrogen before brazing any component or tubing.

WARNING

FIRE OR EXPLOSION HAZARD

Do NOT mix refrigerant with air for leak testing or other purposes.

WARNING

ELECTRIC SHOCK HAZARD

Electrically ground the fan coil. Connect the ground wire to the terminal marked with the ground symbol, ⊕.

Failure to properly ground the unit could result in injury or death. Always disconnect power before servicing and verify power is off to prevent accidental shock.

CAUTION

Devices such as fan switches or thermostats provided for field installation must be wired according to the supplied wiring diagram. Failure to do so could result in damage to components and void the warranty.

PRE-START CHECK

Before starting the unit:

1. Ensure supply voltage matches the nameplate data.
2. Verify the unit is properly grounded.
3. Check blower wheel set screws for tightness and ensure blower wheels rotate freely and quietly.
4. Ensure the fan coil is securely installed and sloped toward the drain line.
5. Verify the condensate line is properly sized, run, trapped, pitched, and tested.

6. Ensure a clean filter is installed and access panels are secured.
7. Check that refrigerant coil connections and piping are leak-free and properly insulated.
8. Seal any knockouts, penetrations, or exposed holes to maintain low air leakage.

WARNING

ELECTRIC SHOCK HAZARD

Disconnect all power supplies before servicing. Lockout/tagout to prevent accidental shock. Ensure all personal protective equipment is worn when servicing or maintaining the unit.

START-UP AND MAINTENANCE

Before start-up, perform the following checks:

- Clean all components of debris to prevent operational issues.
- Ensure all access panels and filters are properly installed.
- Verify unit cleanliness and secure all rotating components.

FAN

Inspect and clean the fan annually in conjunction with motor and bearing maintenance. Keep wheels clean to avoid imbalance and vibration.

MOTOR

Check motor connections for security and compliance with wiring diagrams. For ECM motors, ensure power is disconnected before servicing, as line voltage is always present.

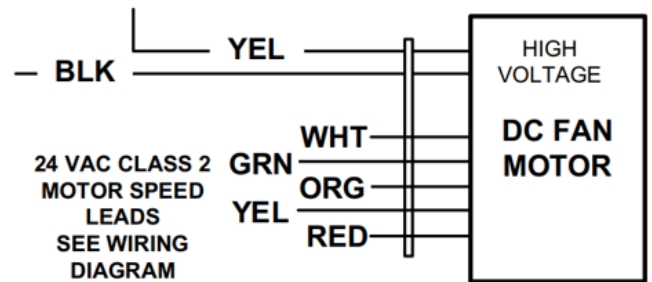

BRUSHLESS DC MOTOR CONNECTIONS
IF SO EQUIPPED

Figure 14 - Brushless DC Motor Connections

OPERATION AND MAINTENANCE (continued)

FILTER

Replace or clean the air filter every 30 days or more frequently under severe conditions. Use the same type as originally furnished.

COIL

Clean dust or contaminants from heat transfer surfaces using one of the following methods:

- Low-pressure compressed air.
- Flushing with water (use a detergent for greasy surfaces).

DRAIN PIPING

Ensure the drain is:

- Properly connected and sloped away from the unit (1/8 in. per foot minimum).
- Checked before summer operation and periodically during operation.

HEATING CYCLE START-UP (HOT WATER COIL UNITS)



WARNING



To prevent damage, the fan coil unit should NOT be energized for heating until the hot water coil and all water lines have been fully purged of air

For Units with No Pump:

1. Fill the water heater and purge air by opening a hot water faucet. Close the faucet once the air is vented.
2. Set the water heater thermostat to 140°F (60°C).
3. Purge air from the water coil and lines using the air bleed valve.



NOTE



Purging may require several gallons of water, so have a bucket or means of discarding water ready.

4. Switch the room thermostat to "Heat" mode and raise the temperature 10°F above room temperature.
5. Verify water circulation by checking for heat at the coil inlet. If necessary, purge remaining air to allow proper flow.



WARNING



Ensure the pump is functioning correctly before operating the unit. Improper operation or air in the system can prevent hot water circulation and damage the system.

For Units with Pumps:

1. Verify the pump is properly installed and operational.
2. Fill the water heater and purge air by opening a hot water faucet. Close the faucet once all air is vented.
3. Ignite the water heater and set the thermostat to 140°F (60°C).
4. Purge the air handler's hot water coil and lines using the air bleed valve.



NOTE



Purging may require several gallons of water, so have a bucket or means of discarding water ready.

5. Switch the room thermostat to the "Heat" position and raise the temperature setting to approximately 10°F above the room temperature.
6. Confirm the pump energizes and begins circulating hot water through the coil. Verify hot water is entering the fan coil unit.
7. If hot water is not circulating, open the air bleed valve again to remove any remaining air.

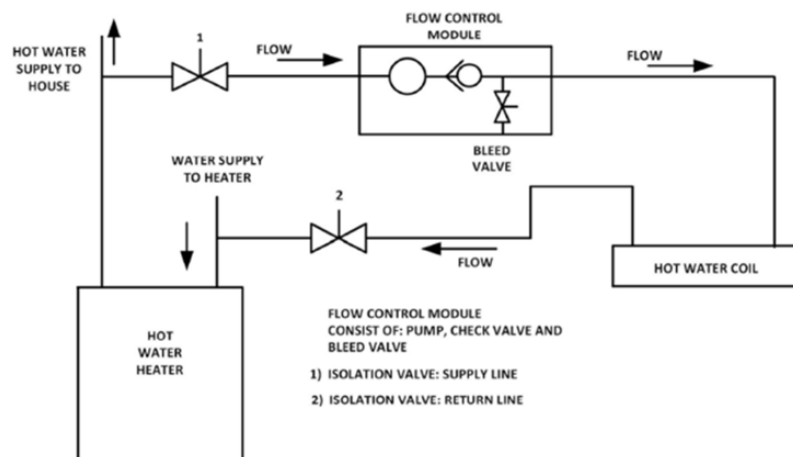

Figure 15 - Hot Water Unit Diagram (with pump)

OPERATION & MAINTENANCE (continued)

REFRIGERANT DETECTION SENSOR (RDS) INFORMATION

For equipment utilizing A2L refrigerants, a refrigerant detection system (RDS) is installed on this unit to detect any A2L refrigerant containing components and will take action to mitigate any risk of ignition/fire.

Refer to the appliance IOM for information regarding the minimum conditioned room requirements, and instructions for the RDS operation, installation, and wiring. Any field installed wiring connected to the RDS must be at least 18AGW and have minimum insulation thickness of 1.58 mm or be protected from damage.

The RDS is NOT intended for service or repair. In the event of a sensor failure, the mitigation mode will engage and the sensor shall be replaced by removing the sensor and replacing it with a new sensor.

False ceilings or drop ceilings may be used as a return air Plenum if a refrigerant detention system is provided in the appliance and any external connections are also provided with a sensor immediately below the return air plenum duct joint.

QUALIFICATION OF WORKERS

Service shall only be performed by qualified technicians, certified by national training organizations or manufacturers that are accredited to teach the relevant national competency standards that may be set in legislation. Competence to properly service the appliance should be documented by a certificate.

CHECKS TO THE WORK AREA

Prior to beginning work on the appliance, safety checks are necessary to ensure that the risk of ignition of released gasses is minimized. Work shall be undertaken under a controlled procedure so as to minimize the risk of a flammable gas or vapor being present while the work is being performed.

All maintenance staff and others working in the local area shall be instructed on the nature of work being carried out. Work in confined spaces shall be avoided.

CHECKING FOR PRESENCE OF REFRIGERANT

The area shall be checked with an appropriate refrigerant detector prior to and during work, to ensure the technician is aware of potentially toxic or flammable atmospheres. Ensure that the leak detection equipment being used is suitable for use with all applicable refrigerants, i.e., non-sparking, adequately sealed or intrinsically safe.

If any hot work is to be conducted on the refrigerating equipment or any associated parts, appropriate fire extinguishing equipment shall be available to hand. Have a dry powder or CO2 fire extinguisher adjacent to the charging area.

No person carrying out work in relation to a REFRIGERATING SYSTEM which involves exposing any such a pipe work shall use any sources of ignition in a manner that it may lead to the risk of fire or explosion.

All possible ignition sources, including cigarette smoking, should be kept sufficiently far away from the site of installation, repairing, removing and disposal, during which refrigerant can possibly be released to the surrounding space. Prior to work taking place, the area around the equipment is to be surveyed to make sure that there are no flammable hazards or ignition risks. "NO SMOKING" signs shall be displayed.

VENTILATED AREA

Ensure that the area is in the open or that it is adequately ventilated before breaking into the system or conducting any hot work. A degree of ventilation shall continue during the period that the work is carried out. The ventilation should safely disperse any released refrigerant and preferably expel it externally into the atmosphere.

OPERATION & MAINTENANCE (continued)

CHECKS TO THE REFRIGERATING EQUIPMENT

Where electrical components are being changed, they shall be fit for the purpose and to the correct specification. At all times the manufacturer's maintenance and service guidelines shall be followed. If in doubt, consult the manufacturer's technical department for assistance.

The following checks shall be applied to installations using FLAMMABLE REFRIGERANTS:

- The actual REFRIGERANT CHARGE is in accordance with the room size within which the refrigerant containing parts are installed;
- The ventilation machinery and outlets are operating adequately and are not obstructed;
- Marking to the equipment continues to be visible and legible. Markings and signs that are illegible shall be corrected;
- Refrigerating pipe or components are installed in a position where they are unlikely to be exposed to any substance which may corrode refrigerant containing components, unless the components are constructed of materials which are inherently resistant to being corroded or are suitably protected against being so corroded.

CHECKS TO ELECTRICAL DEVICES AND SEALED ELECTRICAL COMPONENTS

Repair and maintenance to electrical components shall include initial safety checks and component inspection procedures. If a fault exists that could compromise safety, then no electrical supply shall be connected to the circuit until it is satisfactorily dealt with. If the fault cannot be corrected immediately but it is necessary to continue operation, an adequate temporary solution shall be used. This shall be reported to the owner of the equipment so all parties are advised.

Initial Safety Checks shall include:

- That capacitors are discharged: this shall be done in a safe manner to avoid possibility of sparking;
- That no live electrical components and wiring are exposed while charging, recovering, or purging the system;
- That there is continuity of earth bonding.

Sealed electrical components shall be replaced in the event of damage or malfunction.

CABLING

Check that cabling will not be subject to wear, corrosion, excessive pressure, vibration, sharp edges, or any other adverse environmental effects. The check shall also take into account the effects of aging or continual vibration from sources such as compressors or fans.

REMOVAL AND EVACUATION OF FLAMMABLE REFRIGERANTS

When breaking into the refrigerant circuit to make repairs – or for any other purpose – conventional procedures shall be used. However, for FLAMMABLE REFRIGERANTS it is important that best practice is followed since flammability is a consideration.

The following procedure shall be adhered to:

- Remove refrigerant charge following local and national regulations
- Purge the circuit with inert gas (optional for A2L);
- Evacuate (optional for A2L)
- If using flame to open circuit, continuously flush system with an inert gas
- Open the circuit by cutting or brazing.

The refrigerant charge shall be recovered into the correct recovery cylinders if venting is not allowed by local and national codes. For appliances containing flammable refrigerants, the system shall be purged with oxygen-free nitrogen to render the appliance safe for flammable refrigerants. This process might need to be repeated several times. Compressed air or oxygen shall not be used for purging refrigerant systems.

For appliances containing flammable refrigerants, refrigerant purging shall be achieved by breaking the vacuum in the system with oxygen-free nitrogen and continuing until the working pressure is achieved, then venting to the atmosphere, and finally pulling down to a vacuum (optional for A2L). This process shall be repeated until no refrigerant is within the system (optional for A2L). When the final oxygen-free nitrogen charge is used, the system shall be vented down to atmospheric pressure to enable work to take place.

OPERATION & MAINTENANCE (continued)

The outlet for the vacuum pump shall NOT be close to any potential ignition sources, and ventilation shall be available.

In addition to conventional charging procedures, the following requirements shall be followed.

- Ensure that contamination of different refrigerants does not occur when using charging equipment. Hoses or lines shall be as short as possible to minimize the amount of refrigerant contained in them.
- Cylinders shall be kept in an appropriate position according to the instructions.
- Ensure that the REFRIGERATING SYSTEM is earthed prior to charging the system with refrigerant.
- Label the system when charging is complete (if not already).
- Extreme care shall be taken not to overfill the REFRIGERATING SYSTEM.

Prior to recharging the system, it shall be pressure-tested with the appropriate purging gas. The system shall be leak-tested on completion of charging but prior to commissioning. A follow up leak test shall be carried out prior to leaving the site.

DECOMMISSIONING

Before carrying out this procedure, it is essential that the technician is completely familiar with the equipment and all its detail. It is recommended good practice that all refrigerants are recovered safely. Prior to the task being carried out, an oil and refrigerant sample shall be taken in case analysis is required prior to re-use of recovered refrigerant. It is essential that electrical power is available before the task is commenced.

- A. Become familiar with the equipment and its operation.
- B. Isolate system electrically.
- C. Before attempting the procedure, ensure that:
 - I. mechanical handling equipment is available, if required, for handling refrigerant cylinders;
 - II. all personal protective equipment is available and being used correctly;
 - III. the recovery process is supervised at all times by a competent person;
 - IV. recovery equipment and cylinders conform to the appropriate standards.
- D. Pump down refrigerant system, if possible.
- E. If a vacuum is not possible, make a manifold so that refrigerant can be removed from various parts of the system.
- F. Make sure that cylinder is situated on the scales before recovery takes place.
- G. Start the recovery machine and operate in accordance with instructions.
- H. Do NOT overfill cylinders (no more than 80 % volume liquid charge).
 - I. Do NOT exceed the maximum working pressure of the cylinder, even temporarily.
- J. When the cylinders have been filled correctly and the process completed, make sure that the cylinders and the equipment are removed from site promptly and all isolation valves on the equipment are closed off.
- K. Recovered refrigerant shall not be charged into another REFRIGERATING SYSTEM unless it has been cleaned and checked.

LABELING

Equipment shall be labelled stating that it has been de-commissioned and emptied of refrigerant. The label shall be dated and signed. For appliances containing FLAMMABLE REFRIGERANTS, ensure that there are labels on the equipment stating that the equipment contains FLAMMABLE REFRIGERANT.

RECOVERY

When removing refrigerant from a system, either for servicing order commissioning, it is recommended good practice that all refrigerants are removed safely.

OPERATION & MAINTENANCE (continued)

When transferring refrigerant into cylinders, ensure that only appropriate refrigerant recovery cylinders are employed. Ensure that the correct number of cylinders for holding the total system charge is available. All cylinders to be used are designated for the recovered refrigerant and labelled for that refrigerant (i.e., special cylinders for the recovery of refrigerant). Cylinders shall be complete with pressure-relief valve and associated shut-off valves in good working order. Empty recovery cylinders are evacuated and, if possible, cooled before recovery occurs.

A2L SENSING AND MITIGATION

Air handler units that can be charged with over 4 lbs. (1.81 kg) of R-454B or R-32 refrigerant are shipped with a factory installed refrigerant leak detector attached near the bottom of the evaporator coil. In the event that a refrigerant leak is detected, the controls will disable the compressor operation, and energize the evaporator fan to disperse the leaked refrigerant. The unit will operate in this mitigation state until the sensor no longer detects a refrigerant leak, for a minimum time of 5 minutes. Once the mitigation period has ended, the unit will return to its normal operation based on the current thermostat inputs. An LED status light is provided with the sensor for diagnostic purposes, the description of the LED status light signals can be found in the following table.

Status Light Table for Refrigerant Detection System (RDS)		
Status Light	State/Condition	System Response
Green Blinking	Normal Operation	<ul style="list-style-type: none"> - The system is actively monitoring refrigerant levels. - No refrigerant detected above the activation threshold. - Outdoor unit compressor and indoor blower operate normally.
Red Continuous	Refrigerant Leak Detected	<ul style="list-style-type: none"> - Refrigerant concentration exceeds the activation threshold. - The outdoor unit compressor (Y) is turned off to prevent further circulation of refrigerant. - The indoor blower is turned on to recirculate air and mitigate the refrigerant concentration.
Red Blinking	Fault Detected	<ul style="list-style-type: none"> - A fault in the refrigerant detection system (e.g., calibration issue, end-of-life) has been detected. - The outdoor unit compressor (Y) and indoor blower mitigation mode are deactivated for safety. - System requires inspection or replacement.
No Light	System Off or Malfunction	<ul style="list-style-type: none"> - The system is not operational. - Check the power supply and all system connections.
Amber Blinking	System Initializing	<ul style="list-style-type: none"> - The system is warming up after power-up. - The outdoor unit compressor (Y) and indoor blower mitigation mode remain inactive during this phase. - Transitions to green blinking when monitoring begins.

TABLE 5 – STATUS LIGHT TABLE FOR REFRIGERANT DETECTION SYSTEM (RDS)

MINIMUM ROOM SIZE & MITIGATION AIRFLOW

These fan-coils are compatible with A1 as well as A2L refrigerants. However, additional critical components are required if they are used with A2L refrigerants. If not already pre-configured for A2L refrigerants from the factory a kit that is designed for a particular refrigerant must be field installed to ensure that any leakage of refrigerant is sensed and automatically mitigated.

Additionally, units charged with A2L refrigerants require a minimum room size for the application of the fan-coil as well as a minimum mitigation airflow. Both of these are determined as a function of the total refrigerant charge. The total charge is determined by the charge in the outdoor unit (see outdoor nameplate) plus the charge that was added to the system upon installation.

Minimum Room Size and Mitigation Airflow for R-32 Systems					
System Charge of R*32		Minimum Room Area		Min. Mitigation Airflow	
lbs.	kg	Sq. ft.	Sq. m.	CFM	Cu m/hr
4	1.81	58	5.39	105	178
5	2.27	72	6.74	131	222
6	2.72	87	8.08	157	267
7	3.17	101	9.43	183	311
8	3.63	116	10.78	209	356
9	4.08	130	12.13	236	400
10	4.54	145	13.47	262	445
11	4.99	159	14.82	288	489
12	5.44	174	16.17	314	534
13	5.90	188	17.52	340	578
14	6.35	203	18.86	366	622
15	6.80	217	20.21	393	667
16	7.26	232	21.56	419	711
17	7.71	246	22.90	445	756
18	8.16	261	24.25	471	800
19	8.62	275	25.60	497	845
20	9.07	290	26.95	523	889
21	9.52	304	28.29	550	934
22	9.98	319	29.64	576	978
23	10.43	333	30.99	602	1023
24	10.88	348	32.34	628	1067
25	11.34	362	33.68	654	1112

TABLE 6 - MINIMUM ROOM SIZE AND MITIGATION AIRFLOW FOR R-32 SYSTEMS

Minimum Room Size and Mitigation Airflow for R-454B Systems					
System Charge of R-454B		Minimum Room Area		Min. Mitigation Airflow	
lbs.	kg	Sq. ft.	Sq. m.	CFM	Cu m/hr
4	1.81	60	5.75	108	184
5	2.27	75	6.96	135	230
6	2.72	90	8.36	162	276
7	3.17	105	9.75	189	322
8	3.63	120	11.14	216	368
9	4.08	135	12.54	243	414
10	4.54	150	13.93	271	460
11	4.99	165	15.32	298	506
12	5.44	180	16.71	325	552
13	5.90	195	18.11	352	598
14	6.35	210	19.50	379	644
15	6.80	225	20.89	406	689
16	7.26	240	22.29	433	735
17	7.71	255	23.68	460	781
18	8.16	270	25.07	487	827
19	8.62	285	26.46	514	873
20	9.07	300	27.86	541	919
21	9.52	315	29.25	568	965
22	9.98	330	30.64	595	1011
23	10.43	345	32.04	622	1057
24	10.88	360	33.43	649	1103
25	11.34	375	34.82	676	1149

TABLE 7 - MINIMUM ROOM SIZE AND MITIGATION AIRFLOW FOR R-454B SYSTEMS

For installations in locations above 800 meters the room size and mitigation airflow must be adjusted with a factor from this chart.

Altitude Correction Factor													
Altitude(m)	800	1000	1200	1400	1600	1800	2000	2200	2400	2600	2800	3000	3200
Altitude (ft)	2625	3281	3970	4693	5349	5349	5906	6562	7874	8530	9186	9843	10499
Adj. Factor (AF)	1.02	1.05	1.07	1.1	1.12	1.12	1.15	1.18	1.25	1.28	1.32	1.36	1.4

TABLE 8 - ALTITUDE CORRECTION FACTOR

Data is subject to change. Please verify most current information on www.firstco.com or www.AE-Air.com websites.

A2L SENSOR REPLACEMENT

1. Remove control box cover.
2. Disconnect A2L harness from existing installed sensor.
3. Remove installed A2L sensor from bracket by removing two screws as shown in **Figure 16 - Replacing Sensor to Bracket**. (Use existing screws to install new sensor).
4. Attach new sensor to bracket using two existing screws. See **Figure 16 - Replacing Sensor to Bracket**.
 - a. **TAKE CAUTION – DO NOT SCREW INTO COIL/TUBING.**
5. Connect A2L harness to new installed sensor.

Note: Check that cabling will not be subject to wear, corrosion, excessive pressure, vibration, sharp edges, or any other adverse environmental effects. The check shall also take into account the effects of aging or continual vibration from sources such as compressors or fans.

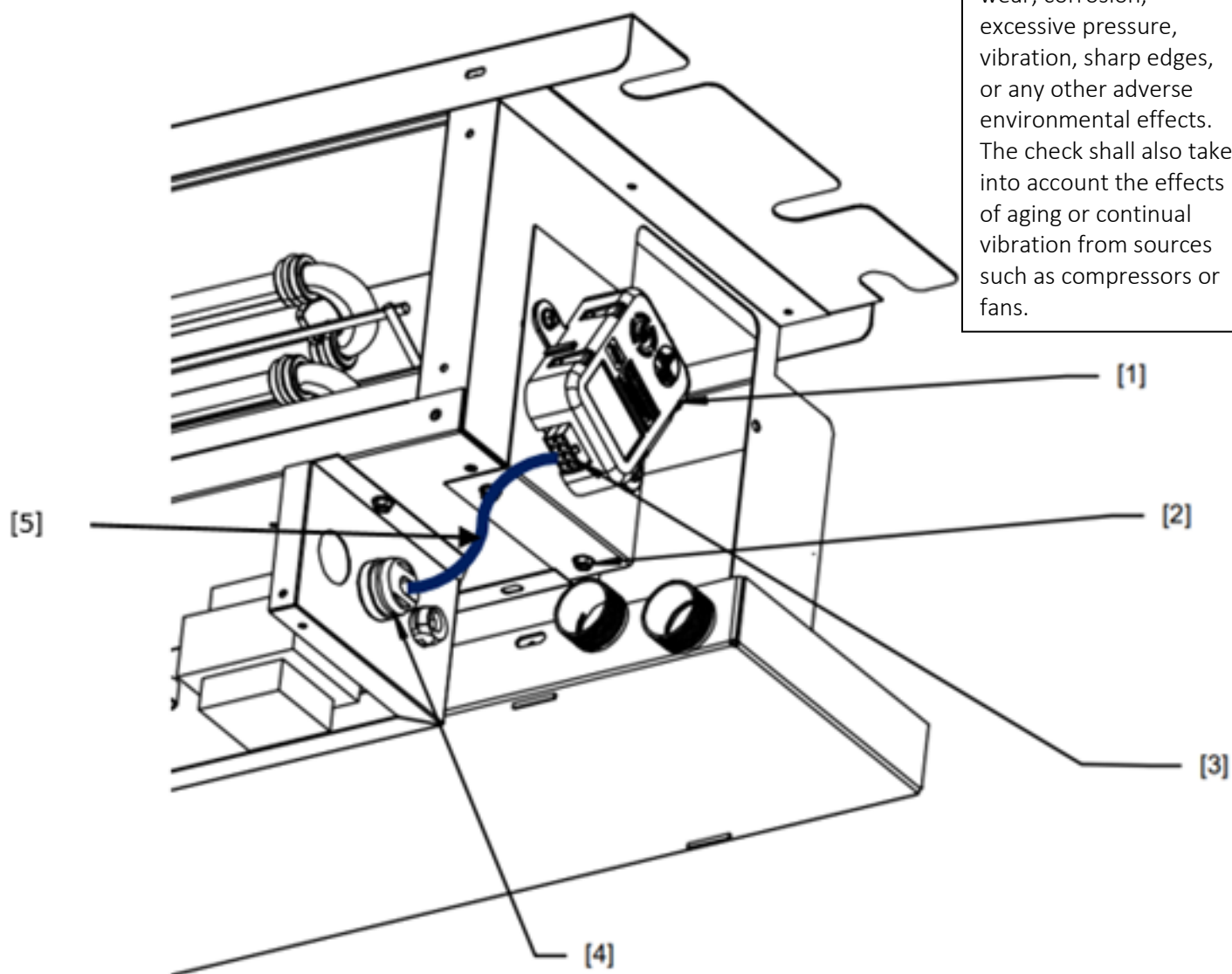

Figure 16 – Replacing Sensor to Bracket

MASSACHUSETTS COMBO SYSTEM LAYOUT

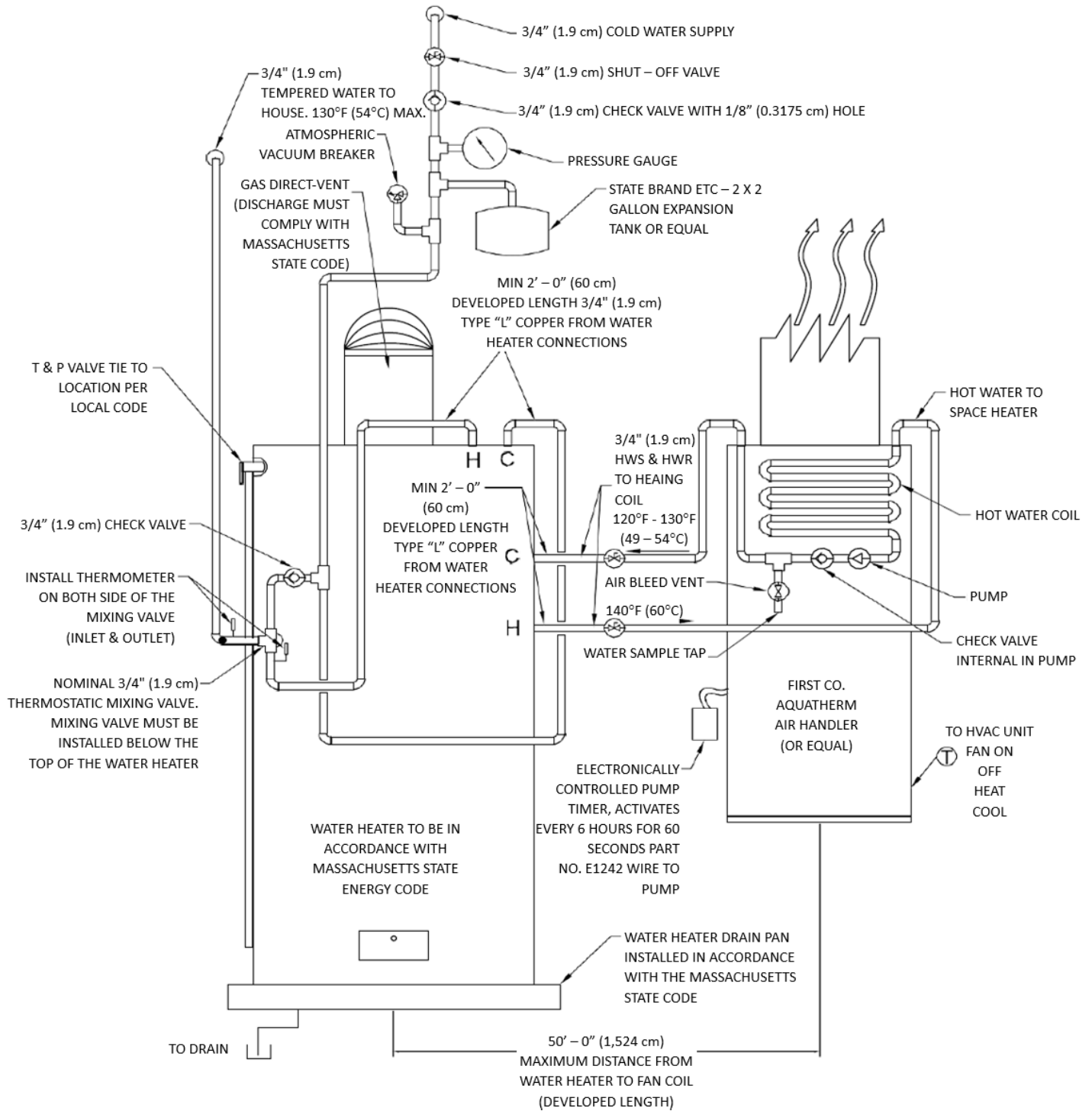

Figure 17 - Massachusetts Combo System Layout

NOTES



P.O. Box 270969 Dallas, TX 75227
www.firstco.com or www.ae-air.com

The manufacturer works to continually improve its products. It reserves the right to change design and specifications without notice.

©2022 First Co., Applied Environmental Air