

*First Co.*

# WCX2 SERIES

*Thru-The-Wall Split Condensing Unit R454B*

WCX2-BA

WCX2-BB

R454B



---

# TABLE OF CONTENTS

NOMENCLATURE .....3

SERIES APPLICATIONS.....4

SERIES FEATURES .....5

DATA TABLES – WCX2-BA.....6

OPTIONAL ACCESSORIES – WCX2-BA.....7

DATA TABLES – WCX2-BB .....8

OPTIONAL ACCESSORIES – WCX2-BB .....9

First Co.’s customer is ultimately responsible for confirming which fan coil models are compatible with selected outdoor unit(s) and which expansion valves (if any) are required. To determine certified indoor/outdoor combinations, go to [www.firstco.com](http://www.firstco.com) or contact the factory.

In keeping with its policy of continuous progress and product improvement, First Co. reserves the right to make changes without notice.

# NOMENCLATURE

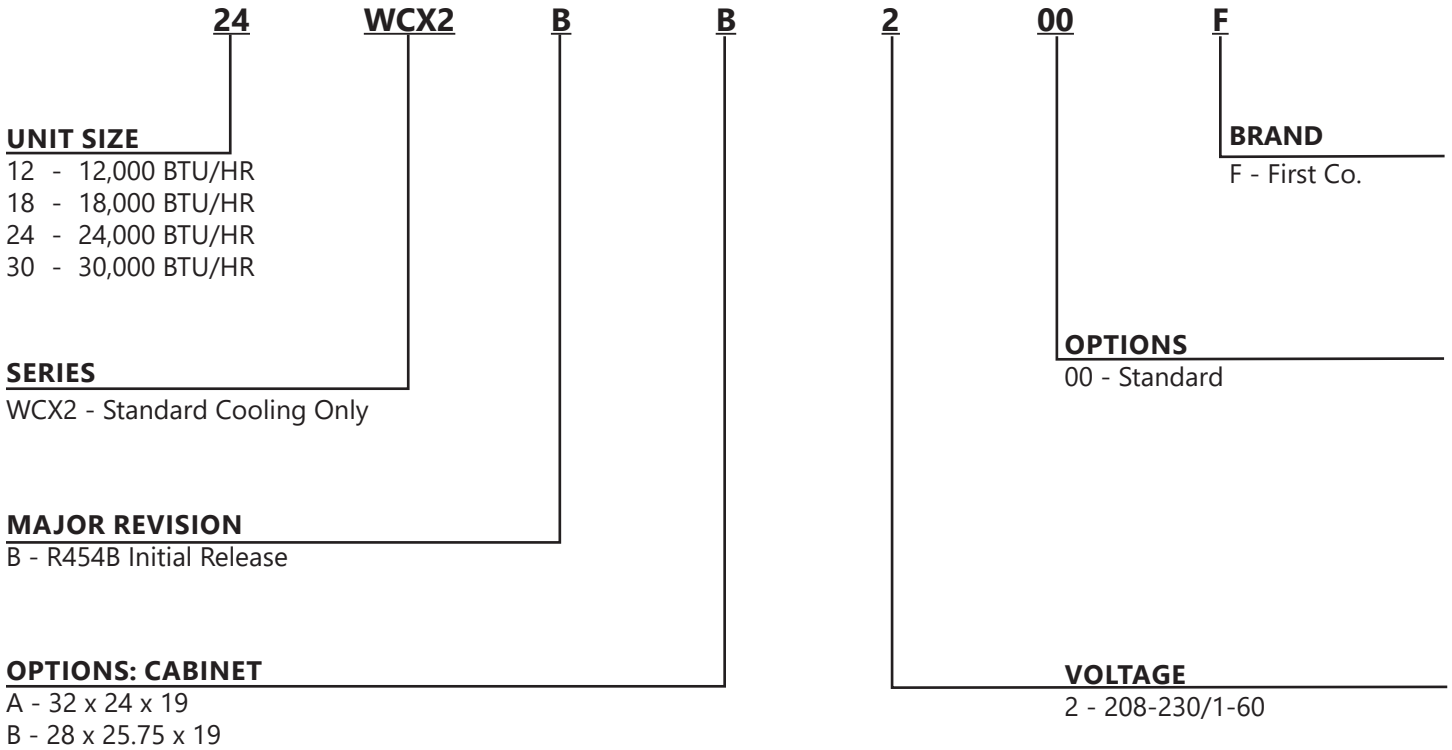

---

# WCX2 SERIES

## THRU-THE-WALL SPLIT CONDENSING UNIT R454B

### APPLICATION

These condensing units are excellent replacement products for the thousands of existing through-the-wall condensing units.

#### THRU-THE-WALL VS CONVENTIONAL CONDENSING UNITS

- Lower Installation Costs - WCX2 condensing units install on the same floor as the apartment, town home, or condominium, resulting in considerable first cost savings in refrigerant, refrigerant piping, and electrical wiring compared to condensing units installed on the ground or roof.
- Easier to Service - Being located on the same floor as the apartment, town home, or condominium, service and routine maintenance of the WCX2 is much easier and can be performed by one person.
- Eliminates theft problems
- No costly landscaping needed to hide the units
- No condensing unit support pads required
- No additional roof support expenses
- No chaseways to roof or ground needed for refrigerant lines

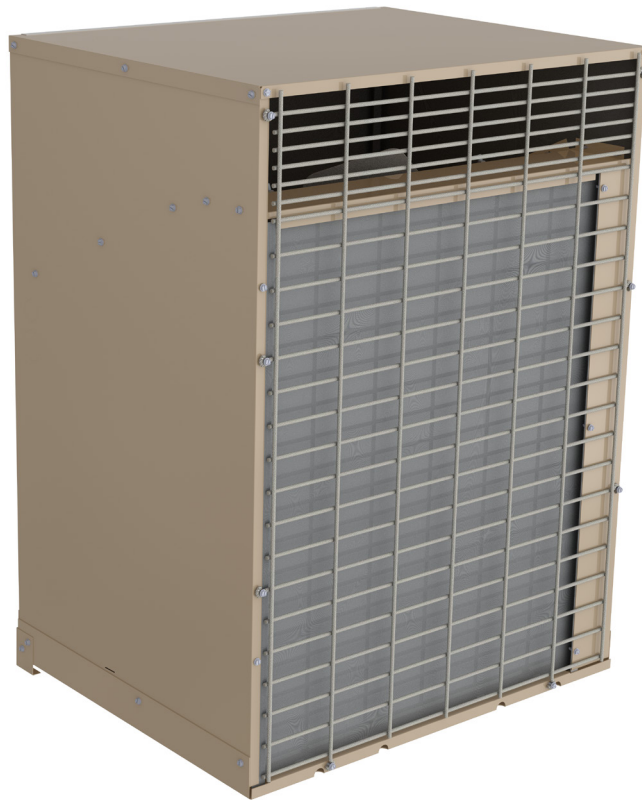

WCX units are sold and intended for use only with blower coil and air handler units with ECM motors.

---

# WCX2 SERIES

## THRU-THE-WALL SPLIT CONDENSING UNIT R454B

### FEATURES

- Factory charged with R-454B refrigerant (charge will need to be field-adjusted)
- Unique cabinet design - unit side panels fit inside rather than outside the base pan to improve water containment on the sides of the cabinet
- Extra-high efficiency scroll or reciprocating R-454B compressor
- High pressure switch
- Propeller type fan - Moves more air over the condenser coil at lower operating watts than standard "squirrel cage" type blower
- Sloped base pan - Positive water drainage from the unit to the building exterior
- Plastic coated coil guard

**NOTE:**

R-454B refrigerant oil is not compatible with R-410A and R-22 oil. Therefore, when R-454B outdoor units are replacing existing R-410A or R-22 outdoor units, the indoor evaporator coil must be replaced with a new one, the coil must include an R-454B TXV, and the interconnecting refrigerant lines flushed.

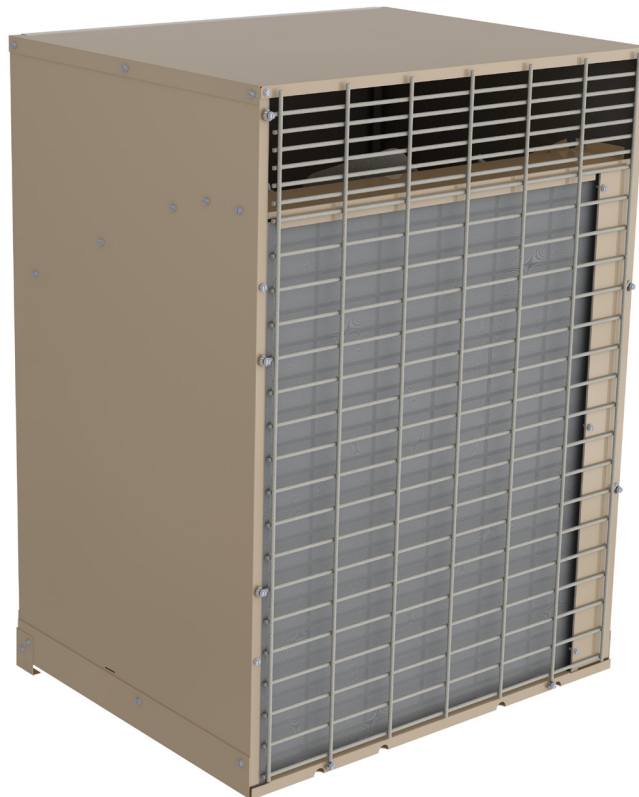

# WCX2 SERIES

## THRU-THE-WALL SPLIT CONDENSING UNIT R454B

# WCX2-BA

## DATA TABLES

ELECTRICAL DATA 208/230V - 1PH - 60 Hz						
UNIT MODEL	COMPRESSOR		CONDENSER FAN		MIN. CIR. AMPACITY	MAX. HACR BREAKER
	LRA	RLA	FLA	HP		
18WCX2-BA	47	7.18	1.2	1/4	11	20
24WCX2-BA	59	9.17	1.2	1/4	13	30
30WCX2-BA	71	10.45	2.8	1/3	17	30

**NOTE:**

Compressor start assist devices (capacitor and start potential relay) may be required on WCX units with scroll compressors for installations with long line length, unusually high or low ambient operating conditions, thermostatic expansion valves or any other situation which can lead to slow off cycle pressure equalization and excessive compressor starting problems.

PHYSICAL DIMENSIONS					
UNIT MODEL	A	B	C	LIQ/SUCT. LINE CONN. (SWEAT)	APPROX. SHIP WT.
18WCX2-BA	32	24	19	3/8 O.D. / 3/4 O.D.	200
24WCX2-BA					
30WCX2-BA					

**NOTE:**

R-454B refrigerant oil is not compatible with R-410A and R-22 oil. Therefore, when R-454B outdoor units are replacing existing R-410A or R-22 outdoor units, the indoor evaporator coil must be replaced with a new one, the coil must include an R-454B TXV, and the interconnecting refrigerant lines flushed.

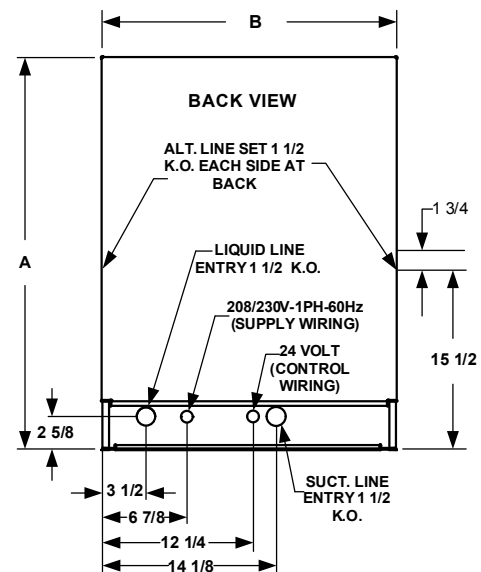
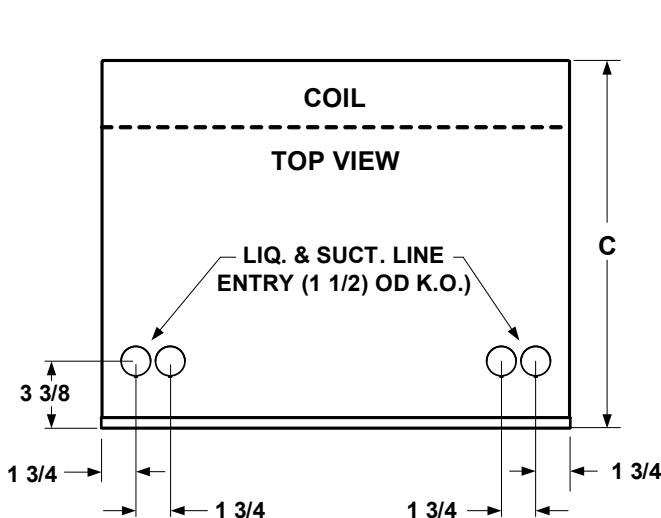

**NOTE:**

Liquid line valve is located on left side.  
Suction line valve is located on right side.

### OPTIONAL ACCESSORIES: WCX2-BA

OPTIONAL ARCHITECTURAL LOUVER (FIELD INSTALLED)				
PART NUMBER	FOR USE ON	DIMENSIONS		
		H	W	D
G200A(PPA)(S) (Standard)	18WCX2-BA 24WCX2-BA 30WCX2-BA	32	24	1-1/4
G210A(PPA)(S) (Hurricane) (Requires Hurricane Sleeve)	18WCX2-BA 24WCX2-BA 30WCX2-BA	34-5/8	26-1/2	1-1/8

**NOTES:**

- "A" = Clear Anodized  
"PPA" = Paint Prepared Aluminum  
"S" Custom Painted
- Louver screws to the "face" of the condensing unit in place of the factory wire guard.
- Louvers can be factory painted almost any color. Contact the factory for additional information and cost.

OPTIONAL INSTALLATION SLEEVE(S) (SEE MATCHING LOUVER)					
PART NUMBER	FOR USE ON	DESCRIPTION	DIMENSIONS		
			H	W	D
928-3 (Standard)	All "BA" models only	Sleeve installs in rough-in to facilitate condensing unit installation and removal for service	33-3/8	24-1/4	11-3/4
928-3H (Hurricane)	All "BA" models only	Hurricane Sleeve	34-1/8	25-3/8	13-3/4



(Optional Architectural Louver)

# WCX2 SERIES

## THRU-THE-WALL SPLIT CONDENSING UNIT R454B

# WCX2-BB

## DATA TABLES

ELECTRICAL DATA 208/230V - 1PH - 60 Hz						
UNIT MODEL	COMPRESSOR		CONDENSER FAN		MIN. CIR. AMPACITY	MAX. HACR BREAKER
	LRA	RLA	FLA	HP		
18WCX2-BB	47	7.18	1.2	1/4	11	20
24WCX2-BB	59	9.17	1.2	1/4	13	30
30WCX2-BB	71	10.45	2.8	1/3	17	30

**NOTE:**

Compressor start assist devices (capacitor and start potential relay) may be required on WCX units with scroll compressors for installations with long line length, unusually high or low ambient operating conditions, thermostatic expansion valves or any other situation which can lead to slow off cycle pressure equalization and excessive compressor starting problems.

PHYSICAL DIMENSIONS					
UNIT MODEL	A	B	C	LIQ/SUCT. LINE CONN. (SWEAT)	APPROX. SHIP WT.
18WCX2-BB	28	25-3/4	19	3/8 O.D. / 3/4 O.D.	200
24WCX2-BB					
30WCX2-BB					

**NOTE:**  
R-454B refrigerant oil is not compatible with R-410A and R-22 oil. Therefore, when R-454B outdoor units are replacing existing R-410A or R-22 outdoor units, the indoor evaporator coil must be replaced with a new one, the coil must include an R-454B TXV, and the interconnecting refrigerant lines flushed.

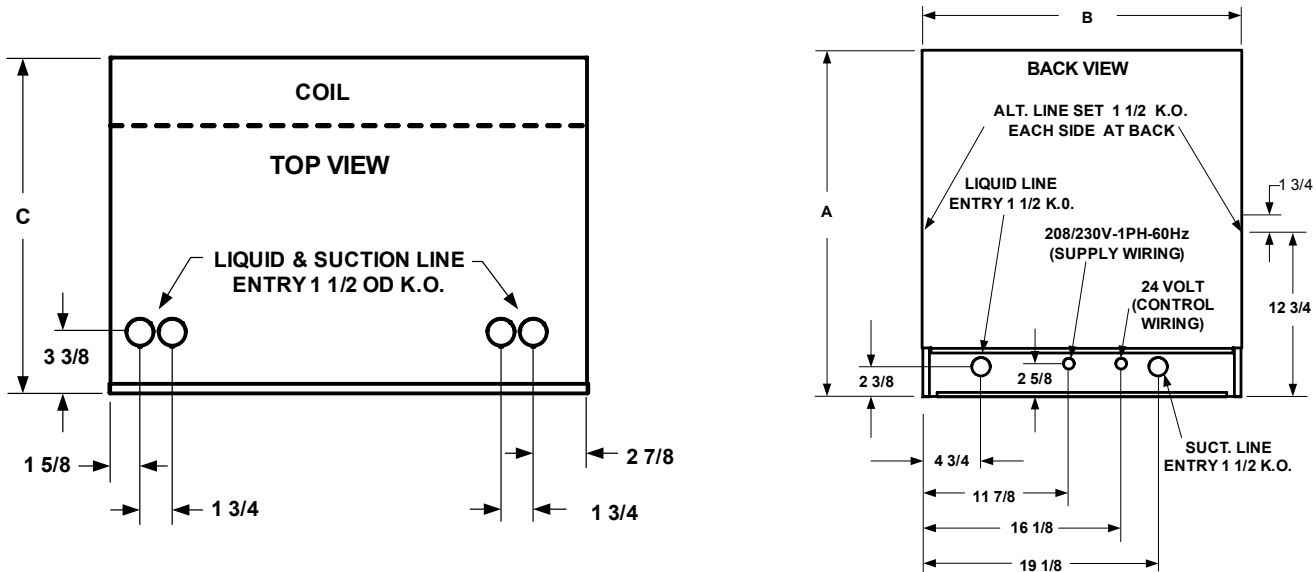

**NOTE:**  
Liquid line valve is located on left side.  
Suction line valve is located on right side.



## OPTIONAL ACCESSORIES: WCX2-BB

OPTIONAL ARCHITECTURAL LOUVER (FIELD INSTALLED)				
PART NUMBER	FOR USE ON	DIMENSIONS		
		H	W	D
G200BBA	18WCX2-BB 24WCX2-BB 30WCX2-BB	28	25-3/4	1-1/4

**NOTES:**

1. G200BBA has clear anodized finish.
2. Louver screws to the "face" of the condensing unit in place of the factory wire guard.



(Optional Architectural Louver)  
Catalog No. WCX(A)1020  
(Replaces wcx(a)718)

**WARNING AVERTISSEMENT ADVERTENCIA**  
Cancer and Reproductive Harm  
Cancer et Troubles de l'appareil reproducteur  
Cáncer y Daño Reproductivo  
[www.P65Warnings.ca.gov](http://www.P65Warnings.ca.gov) LBY0057



*AMERICAN-MADE. FAMILY OWNED.*



FIRST CO.  
P.O. BOX 270969 - DALLAS, TEXAS 75227  
PH. (214) 388-5751 | FAX (214) 388-2255  
[WWW.FIRSTCO.COM](http://WWW.FIRSTCO.COM)

**DECEMBER 2024**