



HX SERIES

HX • HXX • HXS
Ceiling Fan Coils

Horizontal Recessed

Compatible with R32 and R454B

Compatible with R410A for Servicing Existing Equipment Only

Cased and Uncased Available

1.5 - 3 Tons Cooling

0 - 10 kW Electric Heat

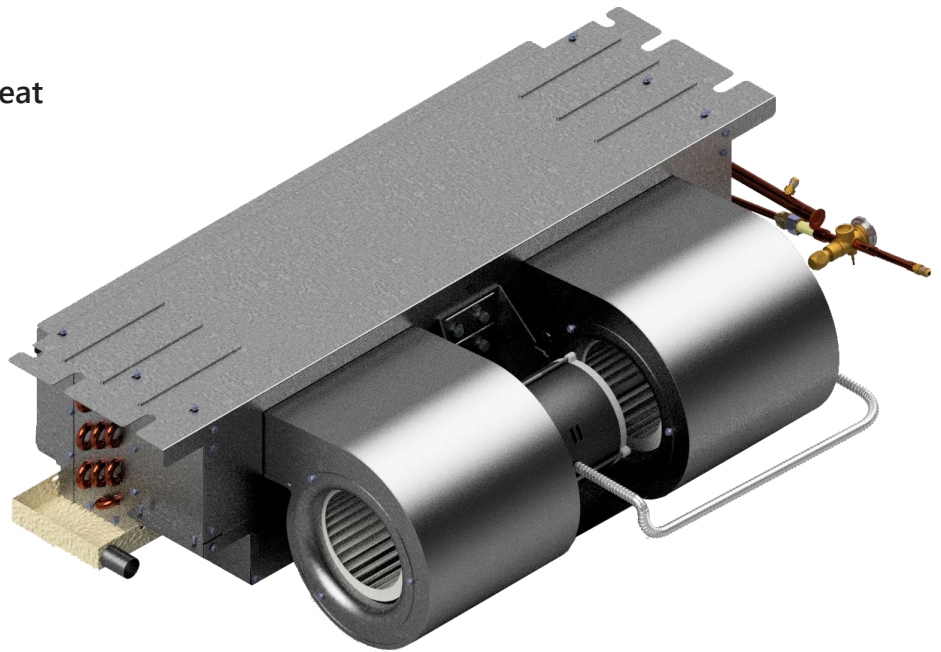

TABLE OF CONTENTS

NOMENCLATURE	3
SERIES FEATURES	4
HX0 DATA	10
HXX DATA.....	11
HXS DATA.....	12
HXSX DATA.....	13

First Co.'s customer is ultimately responsible for confirming which fan coil models are compatible with selected outdoor unit(s) and which expansion valves (if any) are required. To determine certified indoor/outdoor combinations, go to www.firstco.com or contact the factory.

In keeping with its policy of continuous progress and product improvement, First Co. reserves the right to make changes without notice.

NOMENCLATURE

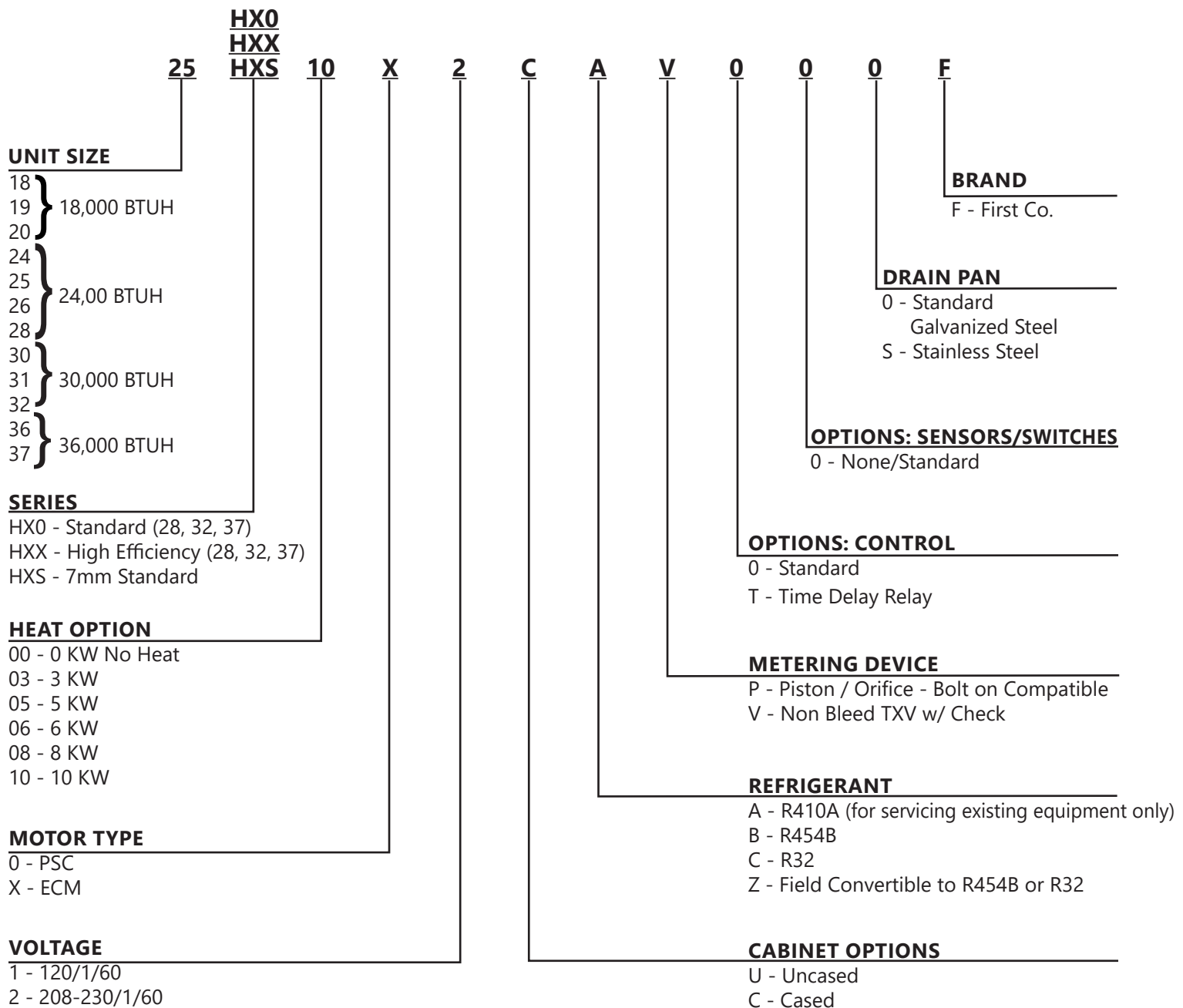

HX SERIES

HX0 • HXX • HXS

Compatible with R410A, R454B, and R32 using non-bleed TXVs. Units ordered for R454B and R32 (Options B and C) are factory configured with TXV or piston and factory-mounted refrigerant sensor.

Field Convertible units (option Z) are available and can be configured only for R454B and R32 with TXV and Refrigerant Sensor Kit.

All HX fan coils include a 240/24V transformer and are completely prewired with 0 to 10 kW of electric heat. A sloped drain pan allows positive drainage of condensate.

The base HX fan coil is an open blower type (non-enclosed) fan coil. It is also available with either a field or factory installed enclosure, with both options of a louvered or solid ceiling panel.

The HX series is compatible with most split system condensing units and heat pumps (heat pumps with electric heat require field added kit).

Contact factory for correct match with outdoor unit or visit AHRI.org.

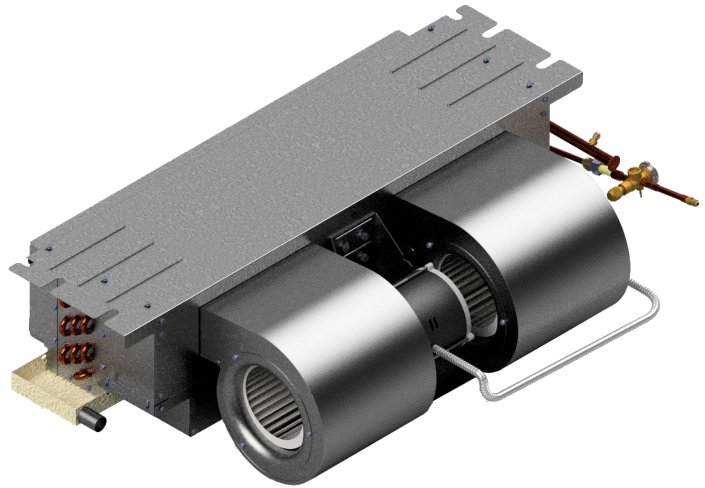

STANDARD FEATURES

- High Efficiency ECM motor for HXX and HXS*X models.
- Drain pan has 3/4" NPT primary and secondary (overflow) fittings 240V motor, 24V controls.
- Insulated and coated galvanized steel drain pan is sloped for proper drainage.
- Cabinet air leakage is no more than 2% when tested in accordance with ASHRAE 193 for cased units.

HX SERIES

OPTIONAL FEATURES

- Attractive off-white return air / access panel with captive screws (panels can be field painted).
- IAQ filter panels
- Fully insulated enclosure with matching ceiling panel (enclosure can be pre-installed) also allows for ducted return air.
- Heat pump kit - for all models with electric heat (#942-1) (field installed).
- Factory or field installed R454B or R32 TXV (non-bleed type). R454B and R32 units will require a Refrigerant Sensor.
- Condensate overflow switch (#SS3) (field installed).
- Enclosure "Cap Kit" for above the ceiling installation (See page 5).
- Optional bolt on filter box for cased units.

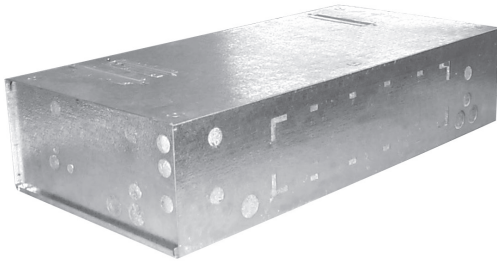

Optional Insulated Enclosure



Matching Access Panel for Enclosure
(non-louvered shown)

CEILING ACCESS PANELS FOR MODELS INSTALLED WITHOUT ENCLOSURE

STANDARD PANELS		IAQ PANELS
# 965-1 966-1 967-1 967-7	# 965 966 967 967-6 (Louvers may differ from picture) Louvered panels accept 20" x 20" x 1" filter (field supplied).	# 965-M8 (accepts 1-20" x 30" x 1" filter) # 966-M8, 967-M8 (accepts 2-20" x 20" x 1" filter) # 967-6-M8 (accepts 2-20" x 25" x 1" filter) (GlasFloss® Industries Series HV filter or equivalent is recommended)

HX SERIES

CEILING ACCESS PANELS (CONT'D) FOR MODELS INSTALLED WITHOUT ENCLOSURE

STANDARD & IAQ PANELS							
MODEL SIZE	PANEL NO. (STD.)	PANEL NO. (IAQ)	DESCRIPTION	CEILING PANEL OPENING		PANEL FRAME DIMS. (OUTSIDE)	
18, 19, 24 HXS/*X	965	965-M8	LOUVERED	24-1/2	40	27-1/2	43
	965-1	NA	NON-LOUVERED	24-1/2	40	27-1/2	43
20, 25, 30 HXS/*X	966	966-M8	LOUVERED	24-1/2	46	27-1/2	49
	966-1	NA	NON-LOUVERED	24-1/2	46	27-1/2	49
26, 31, 36 HXS/*X	967	967-M8	LOUVERED	24-1/2	52-1/2	27-1/2	55-1/2
	967-1	NA	NON-LOUVERED	24-1/2	52-1/2	27-1/2	55-1/2
28, 32, 37 HX/X/S/*X	967-6	967-6-M8	LOUVERED	24-1/2	60	27-1/2	63
	967-7	NA	NON-LOUVERED	24-1/2	60	27-1/2	63

ENCLOSURE WITH CEILING PANELS PANELS SOLD SEPARATELY FOR CASED AND UNCASSED UNITS.

ENCLOSURE WITH CEILING PANELS DATA											
MODEL SIZE	ENCLOSURE NO.	ENCLOSURE DIMENSIONS			PANEL NO. (STD.)	PANEL NO. (IAQ)	DESCRIPTION (2)	CEILING PANEL OPENING		PANEL FRAME DIMS(OUTSIDE)	
		H	W	D				W	L	W	L
18, 19, 24 HXS/*X	9EHX01	11	39-3/4	23-7/8	965	965-M8*	LOUVERED	24-1/2	40	27-1/2	43
					965-1	NA	NON-LOUVERED	24-1/2	40	27-1/2	43
20, 25, 30 HXS/*X	9EHX02	11	45-3/4	23-7/8	966	966-M8*	LOUVERED	24-1/2	46	27-1/2	49
					966-1	NA	NON-LOUVERED	24-1/2	46	27-1/2	49
26, 31, 36 HXS/*X	9EHX03	11	51-3/4	23-7/8	967	967-M8*	LOUVERED	24-1/2	52-1/2	27-1/2	55-1/2
					967-1	NA	NON-LOUVERED	24-1/2	52-1/2	27-1/2	55-1/2
28, 32, 37 HX/X/S/*X	9EHX04	11	58-3/4	23-7/8	967-6	967-6-M8*	LOUVERED	24-1/2	60	27-1/2	63
					967-7	NA	NON-LOUVERED	24-1/2	60	27-1/2	63

(See Panel Pictures On Page 4)

NOTES:

- (1) Panels do not mount to cases.
- (2) Panels are sold separately from cases or cased units.
- (*) Add -2 to end of panel number for panel that accepts 2" filter.

HX SERIES

CAP KIT

PANELS SOLD SEPARATELY FOR CASED AND UNCASSED UNITS.

CAP KIT - FOR INSTALLATION ABOVE A SUSPENDED CEILING		
PART NUMBER	FITS ENCLOSURE NUMBER	FOR UNIT MODEL
9PHX01	9EHX01	18, 19, 24HXS-C
9PHX02	9EHX02	20, 25, 30HXS-C
9PHX03	9EHX03	26, 31, 36HXS-C
9PHX04	9EHX04	28, 32, 37HX/X/S-C

NOTES:

- (1) Cap kit is an insulated panel that covers the entire bottom opening of the enclosure (requires ducted return)
- (2) Cap kit would be used in lieu of the ceiling panel and mounts to the case.

TXV KIT

IMPORTANT NOTE

When these units are used with A2L refrigerants they must be fitted with a REFRIGERANT SENSOR and if using a TXV then the TXV must be compatible with the A2L refrigerant that is used. Failure to use a REFRIGERANT SENSOR may result in unit damage, property damage and/or death. Warranty will be void.

EXPANSION VALVE/REFRIGERANT SENSOR KITS (HEAT PUMP OR COOLING ONLY)		
PART NUMBER	TYPE	SENSOR
9EVR410-1	R410A	NO SENSOR
9EVR454B-1	R454B	CE100
9EVR32-1	R32	CE100
9EVR454B-1A	R454B	NO SENSOR
9EVR32-1A	R32	NO SENSOR
9EVRA2L-1	R454B/R32	CE100

NOTES:

- (1) Above expansion valve kits are approved for both cooling only (non heat pump) or heat pump applications.
- (2) Valves are non-bleed type. Field added. Hard start kit may be required.
- (3) Valves have screw-on connections.
- (4) Field installed for Field Convertible (Z) option.

HEAT PUMP KIT

HEAT PUMP KIT (FIELD INSTALLED)	
PART NUMBER	DESCRIPTION
942-1	KIT FOR HX MODELS WITH ELECTRIC HEAT

NOTES:

- (1) Heat pump kit must be field installed for all HX models with electric heat. 0 kW models do not require kit.
- (2) Contact the factory for compatibility match with condensing unit.

Data is subject to change. Please verify most current information on www.firstco.com website.

HX SERIES

MERV RATED FILTER BOX FOR ENCLOSURES



Single filter for size 18-30 & 9EHX01, 9EHX02
Part Number 1000-1

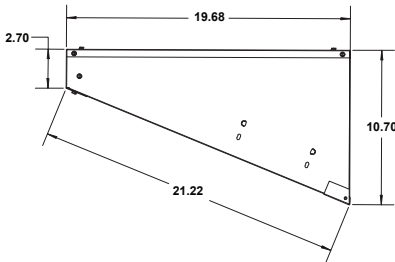

Side View

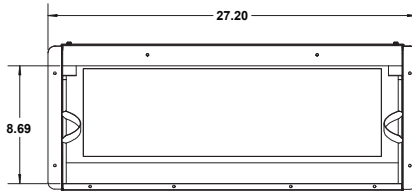

Attach View

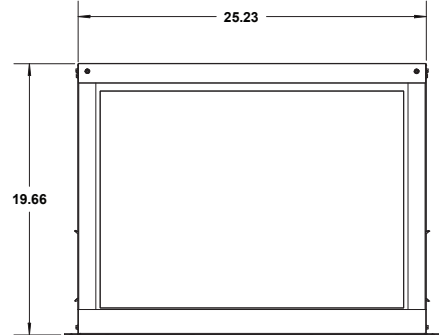

Bottom View



Double filter for size 31-36 & 9EHX03, 9EHX04
Part Number 1000-2

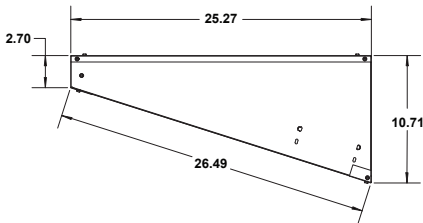

Side View

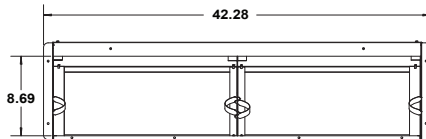

Attach View

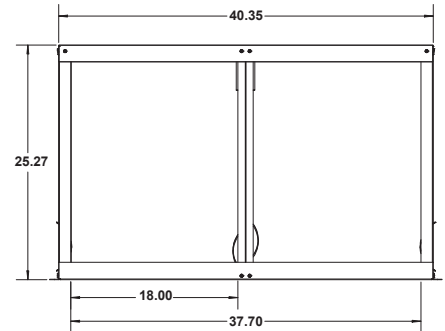

Bottom View

ENCLOSURE

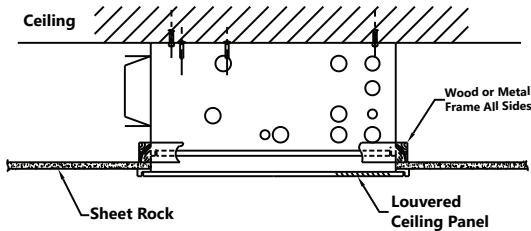

Installation Support Framing

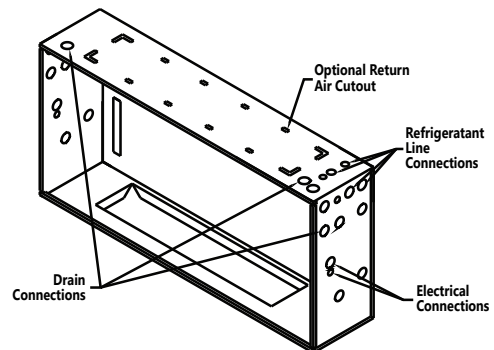

Connection Locations

HX SERIES

1.5 - 3.0 TONS / DIMENSIONS

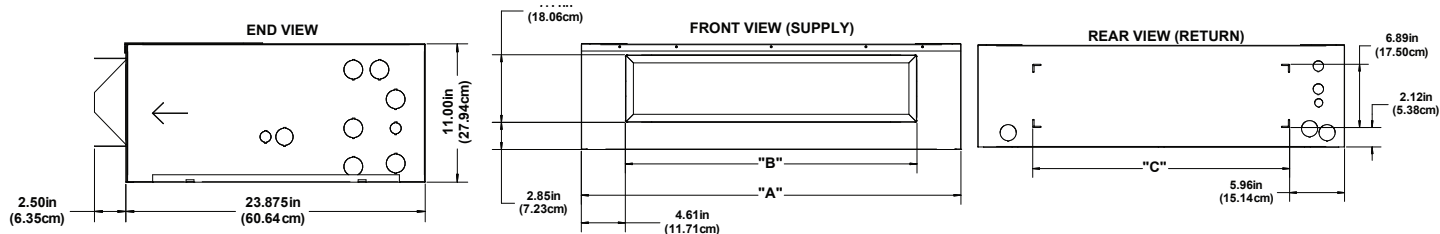

ENCLOSURE DIMENSIONS

MODEL NUMBER	ENCLOSURE NUMBER	A	B	C
18, 19, 24HXS	9EHX01	39-3/4	30-5/8	28
20, 25, 30HXS	9EHX02	45-3/4	36-5/8	34
26, 31, 36HXS	9EHX03	51-3/4	42-5/8	40
28, 32, 37HX/X/	9EHX04	58-3/4	50	46-3/4

PHYSICAL DIMENSIONS

MODEL	A	B	C	D
18, 19, 24HXS	37-1/4	34-11/16	30	6-1/2
20, 25, 30HXS	43-1/4	40-11/16	36	6-1/2
26, 31, 36HXS	49-1/4	46-11/16	42	6-1/2
28, 32, 37HX/X	56-1/4	53-11/16	49	6-1/2



Picture shown is enclosure with installed HXS (Available from the factory as a complete unit)

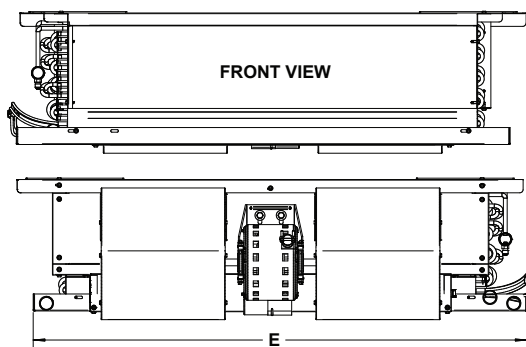
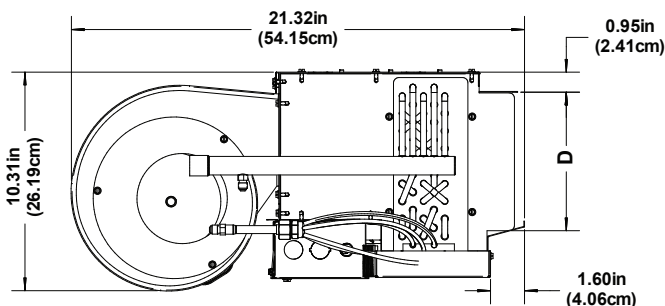
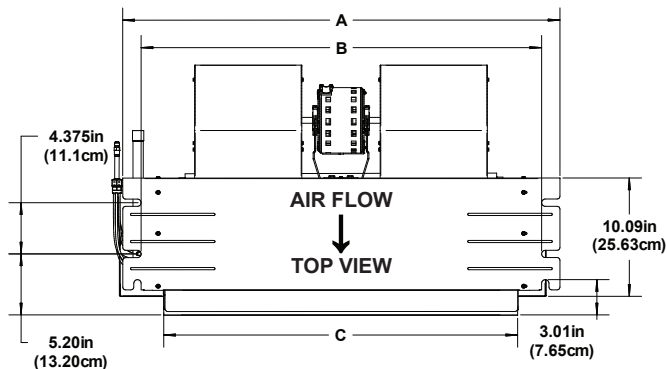

HX SERIES

1.5 - 3.0 TONS ELECTRICAL AND BLOWER DATA

HX0

DATA TABLES

HX ONLY • ELECTRICAL DATA											
UNIT MODEL	NOM. CFM	NOM. COOL BTUH	HEAT Kw			TOTAL AMPS	MIN. CIR. AMPACITY		(2) MAX FUSE		
			208V	240V	BTUH		208V	240V	208V	240V	
28HX	800	24,000	---	---	---	2.0	3	3	15	15	
			-03	2.3	3	10,200	14.5	16	20	20	20
			-05	3.8	5	17,000	22.8	25	30	25	30
			-06	4.5	6	20,500	27.0	29	35	30	35
			-08	6.0	8	27,300	35.3	39	47	40	50
			-10	7.5	10	34,100	43.6	48	55	50	60
32HX	1000	30,000	---	---	---	2.0	3	3	15	15	
			-03	2.3	3	10,200	14.5	16	20	20	20
			-05	3.8	5	17,000	22.8	25	30	25	30
			-06	4.5	6	20,500	27.0	29	35	30	35
			-08	6.0	8	27,300	35.3	39	47	40	50
			-10	7.5	10	34,100	43.6	48	55	50	60
37HX	1200	36,000	---	---	---	2.8	4	4	15	15	
			-03	2.3	3	10,200	15.3	18	20	20	20
			-05	3.8	5	17,000	23.6	27	30	30	30
			-06	4.5	6	20,500	27.8	31	35	35	35
			-08	6.0	8	27,300	36.1	40	46	40	50
			-10	7.5	10	34,100	44.5	49	56	50	60

- (1) All BTUH heating ratings at 240V - derate heating capacities by 25% for 208V
 (2) Maximum fuse or HACR-type circuit breaker.

HX ONLY • BLOWER DATA								
UNIT MODEL	MOTOR HP (240V)	CFM vs. EXTERNAL STATIC PRESSURE						
		0.00	0.05	0.10	0.15	0.20	0.25	0.30
28HX	1/4	910	875	840	805	770	730	690
32HX	1/4	1170	1140	1110	1075	1040	1000	960
37HX	1/3	1460	1420	1380	1340	1300	1250	1200

- (1) Add .05 static when enclosure is used.

HX SERIES

1.5 - 3.0 TONS ELECTRICAL AND BLOWER DATA



DATA TABLES

HXX • ELECTRICAL DATA												
UNIT MODEL	NOM. CFM	NOM. COOL BTUH	HEAT kW			TOTAL AMPS		MIN. CIR. AMPACITY		MAX FUSE		
			208V	240V	BTUH	208V	240V	208V	240V	208V	240V	
28HXX	800	24,000	---	---	---	4.3	4.3	6	6	15	15	
			-03	2.3	3	10,200	15.2	16.8	19	21	20	25
			-05	3.8	5	17,000	22.4	25.2	28	32	30	35
			-06	4.5	6	20,500	26.0	29.3	33	37	35	40
			-08	6.0	8	27,300	33.2	37.7	42	47	50	50
			-10	7.5	10	34,100	40.4	46.0	51	58	60	60
32HXX	1000	30,000	---	---	---	4.3	4.3	6	6	15	15	
			-03	2.3	3	10,200	15.2	16.8	19	21	20	25
			-05	3.8	5	17,000	22.4	25.2	28	32	30	35
			-06	4.5	6	20,500	26.0	29.3	33	37	35	40
			-08	6.0	8	27,300	33.2	37.7	42	47	50	50
			-10	7.5	10	34,100	40.4	46.0	51	58	60	60
37HXX	1200	36,000	---	---	---	4.3	4.3	6	6	15	15	
			-03	2.3	3	10,200	15.2	16.8	19	21	20	25
			-05	3.8	5	17,000	22.4	25.2	28	32	30	35
			-06	4.5	6	20,500	26.0	29.3	33	37	35	40
			-08	6.0	8	27,300	33.2	37.7	42	47	50	50
			-10	7.5	10	34,100	40.4	46.0	51	58	60	60

- (1) All BTUH heating ratings at 240V - derate heating capacities by 25% for 208V
- (2) Maximum fuse or HACR-type circuit breaker.

HXX • BLOWER DATA														
UNIT MODEL	MOTOR HP (240V)	SPEED TAP	MOTOR BHP	NOM. AMPS	CFM vs. EXTERNAL STATIC PRESSURE									
					0.00	0.05	0.10	0.15	0.20	0.25	0.30	0.35	0.40	.50
28HXX	1/2	OPTIONAL HIGH	.30	2.1	970	950	930	910	890	870	850	825	800	755
		STD. HIGH	.20	1.5	810	790	770	745	720	705	690	-	-	-
		STD. LOW	.16	1.0	720	690	660	645	630	615	600	-	-	-
32HXX	1/2	OPTIONAL HIGH	.43	3.3	1280	1245	1210	1180	1150	1115	1080	1025	970	870
		STD. HIGH	.32	2.2	1090	1050	1010	985	960	930	900	-	-	-
		STD. LOW	.24	1.5	950	920	890	855	820	790	760	-	-	-
37HXX	1/2	OPTIONAL HIGH	.51	4.0	1430	1400	1370	1355	1320	1295	1270	1220	1170	1085
		STD. HIGH	.43	3.3	1260	1225	1190	1160	1130	1115	1100	-	-	-
		STD. LOW	.32	2.2	1110	1080	1050	1025	1000	970	940	-	-	-

- (1) Add .05 static when enclosure is used.
- ** Does not include electric heat
- ** (---) Does not meet the minimum 350 CFM requirement

HX SERIES

1.5 - 3.0 TONS ELECTRICAL AND BLOWER DATA

HXS

DATA TABLES

HXS • ELECTRICAL DATA											
UNIT MODEL		NOM. CFM	NOM. COOL BTUH	HEAT Kw			TOTAL AMPS	MIN. CIR. AMPACITY		(2) MAX FUSE	
				208V	240V	BTUH		208V	240V	208V	240V
18 HXS	-05	600	18,000	2.3	5	17,000	22.8	25	30	25	30
	-06			3.8	6	20,500	27.0	30	35	30	35
19 & 20 HXS	-00	600	18,000	---	---	---	1.0	2	2	15	15
	-03			2.3	3	10,200	13.5	15	18	15	20
	-05			3.8	5	17,000	21.8	24	30	25	30
	-06			4.5	6	20,500	26.0	29	35	30	35
	-08			6.0	8	27,300	34.3	38	47	40	50
24, 25 HXS & 26 HXS	-00	800	24,000	---	---	---	2.0	3	3	15	15
	-03			2.3	3	10,200	14.5	16	20	20	20
	-05			3.8	5	17,000	22.8	25	30	25	30
	-06			4.5	6	20,500	27.0	29	35	30	35
	-08			6.0	8	27,300	35.3	39	47	40	50
	-10			7.5	10	34,100	43.6	48	55	50	60
30 & 31 HXS	-00	1000	30,000	---	---	---	2.0	3	3	15	15
	-03			2.3	3	10,200	14.5	16	20	20	20
	-05			3.8	5	17,000	22.8	25	30	25	30
	-06			4.5	6	20,500	27.0	29	35	30	35
	-08			6.0	8	27,300	35.3	39	47	40	50
	-10			7.5	10	34,100	43.6	48	55	50	60
36 HXS	-00	1200	36,000	---	---	---	2.8	4	4	15	15
	-03			2.3	3	10,200	15.3	18	20	20	20
	-05			3.8	5	17,000	23.6	27	30	30	30
	-06			4.5	6	20,500	27.8	31	35	35	35
	-08			6.0	8	27,300	36.1	40	46	40	50
	-10			7.5	10	34,100	44.5	49	56	50	60

(1) All BTUH heating ratings at 240V - derate heating capacities by 25% for 208V

(2) Maximum fuse or HACR-type circuit breaker.

HXS • BLOWER DATA								
UNIT MODEL	MOTOR HP (240V)	CFM vs. EXTERNAL STATIC PRESSURE						
		0.00	0.05	0.10	0.15	0.20	0.25	0.30
18HXS	1/8	810	775	740	705	670	640	610
19HXS	1/8	820	785	750	715	680	650	620
20HXS	1/8	850	815	780	745	710	670	630
24HXS	1/4	910	875	840	805	770	730	690
25HXS	1/4	930	895	860	825	790	750	710
26HXS	1/4	960	925	890	850	810	770	730
30, 31HXS	1/4	1110	1075	1040	990	940	900	860
36HXS	1/3	1410	1370	1330	1290	1250	1210	1170

(1) Add .05 static when enclosed is used.

HX SERIES

1.5 - 3.0 TONS ELECTRICAL AND BLOWER DATA

HXS*X

DATA TABLES

HXS*X • ELECTRICAL DATA												
UNIT MODEL		NOM. CFM	NOM. COOL BTUH	HEAT Kw			TOTAL AMPS		MIN. CIR. AMPACITY		(2) MAX FUSE	
				208V	240V	BTUH	208V	240V	208V	240V	208V	240V
18, 19 & 20 HXS*X	-00	600	18,000	---	---	---	4.3	4.3	6	6	15	15
	-03			2.3	3	10,200	15.2	16.8	19	21	20	25
	-05			3.8	5	17,000	22.4	25.2	28	32	30	35
	-06			4.5	6	20,500	26.0	29.3	33	37	35	40
	-08			6.0	8	27,300	33.2	37.7	42	47	50	50
	-10			7.5	10	34,100	40.4	46.0	51	58	60	60
24, 25 & 26 HXS*X	-00	800	24,000	---	---	---	4.3	4.3	6	6	15	15
	-03			2.3	3	10,200	15.2	16.8	19	21	20	25
	-05			3.8	5	17,000	22.4	25.2	28	32	30	35
	-06			4.5	6	20,500	26.0	29.3	33	37	35	40
	-08			6.0	8	27,300	33.2	37.7	42	47	50	50
	-10			7.5	10	34,100	40.4	46.0	51	58	60	60
30 & 31 HXS*X	-00	1000	30,000	---	---	---	4.3	4.3	6	6	15	15
	-03			2.3	3	10,200	15.2	16.8	19	21	20	25
	-05			3.8	5	17,000	22.4	25.2	28	32	30	35
	-06			4.5	6	20,500	26.0	29.3	33	37	35	40
	-08			6.0	8	27,300	33.2	37.7	42	47	50	50
	-10			7.5	10	34,100	40.4	46.0	51	58	60	60

(1) All BTUH heating ratings at 240V - derate heating capacities by 25% for 208V

(2) Maximum fuse or HACR-type circuit breaker.

HXS*X • BLOWER DATA														
UNIT MODEL	MOTOR HP (240V)	SPEED TAP	MOTOR BHP	NOM. AMPS	CFM vs. EXTERNAL STATIC PRESSURE									
					0.00	0.05	0.10	0.15	0.20	0.25	0.30	0.35	0.40	0.50
18 & 19 HXS*X	1/2	OPTIONAL HIGH	.16	1.2	800	765	730	695	660	620	580	535	490	395
		STD. HIGH	.10	.08	660	630	600	575	550	525	500	-	-	-
		STD. LOW	.08	.07	590	555	520	495	470	445	420	-	-	-
20 HXS*X	1/2	OPTIONAL HIGH	.16	1.2	800	765	730	695	660	620	580	535	490	395
		STD. HIGH	.10	0.8	650	625	600	575	550	525	500	-	-	-
		STD. LOW	.08	0.7	590	560	530	505	480	455	430	-	-	-
24 HXS*X	1/2	OPTIONAL HIGH	.31	1.2	1000	985	965	950	935	915	900	885	865	830
		STD. HIGH	.23	1.5	860	840	820	800	780	765	745	-	-	-
		STD. LOW	.17	1.0	715	685	660	640	615	595	580	-	-	-
25 HXS*X	1/2	OPTIONAL HIGH	.30	2.1	970	950	930	910	890	870	850	825	800	755
		STD. HIGH	.20	1.5	810	790	770	745	720	705	690	-	-	-
		STD. LOW	.06	1.0	720	690	660	645	630	615	600	-	-	-
26 HXS*X	1/2	OPTIONAL HIGH	.30	2.1	1010	980	950	925	900	880	860	840	820	795
		STD. HIGH	.20	1.5	840	810	780	760	740	720	700	-	-	-
		STD. LOW	.16	1.0	750	715	680	655	630	615	600	-	-	-
30 & 31 HXS*X	1/2	OPTIONAL HIGH	.43	3.3	1230	1195	1160	1140	1120	1090	1060	995	930	825
		STD. HIGH	.32	2.2	1060	1015	970	945	920	875	830	-	-	-
		STD. LOW	.24	1.5	920	885	850	810	770	735	700	-	-	-

(1) Add .05 static when enclosed is used.

** Does not include electric heat

** (---) Does not meet the minimum 350 CFM requirement

Approved for installation with 0" clearance to combustible materials





AMERICAN-MADE. FAMILY OWNED.



FIRST CO.
P.O. BOX 270969 - DALLAS, TEXAS 75227
PH. (214) 388-5751 | FAX (214) 388-2255
WWW.FIRSTCO.COM

NOVEMBER 2024