

NEW 2.5 Ton
11.0 EER!!



SPXC / SPXC-HP Series Single Package Vertical Unit Straight Cool and Heat Pump 3/4 through 2.5 tons, up to 10 kW Electric Heat



The SPXC Series "Suite 20" is a compact, through-the-wall single package vertical HVAC unit that delivers conditioned air from a single unit to multiple rooms. The SPXC series is available in straight cool (SPXC) or heat pump (SPXC-HP) models. Having a small footprint allows the SPXC to use a minimal amount of floor space. The SPXC installs easily into a closet having an exterior wall. Like your home, a standard wall mounted thermostat controls the SPXC unit. Applications for the SPXC include:

- Hotels / Motels
- High rise apartments / Condominiums
- Assisted Living / Independent care facilities
- Student housing
- Manufactured / Modular buildings

Standard Features: (see pages 5 and 6 for further information)

- Completely pre-charged with environmentally friendly R-410A refrigerant
- Easy access for in-place service of most components
- Multi-function micro-processor board that includes the following functions:
 - Evaporator coil low temperature protection
 - Low ambient lockout
 - ECM motor utilized on all models
 - Random restart
 - Compressor restart delay
 - Fan-off delay in the cooling mode
 - Low voltage fuse protection
- Service disconnect
- Completely insulated cabinet for sound attenuation and weather infiltration
- Adjustable fresh air damper
- No tool needed to replace the filter
- Weight-supporting, single piece wall sleeves (except side access sleeves) for various wall thicknesses from 5" to 20"
- Sleeves have primary condensate drain connection with secondary overflow to building exterior
- All sleeves are shipped with a weather guard
- Flush type exterior architectural grilles

Optional Features: (see page 10-11)

- Side access wall sleeves (rear access is standard)
- Custom painted exterior architectural grilles
- Hurricane grille / sleeve combinations
- Various louvered and non-louvered interior access panels
- Digital wall mount thermostats with high and low temperature limits
- **(NEW!) Insulation Kit** - Adds additional 5/8" insulation to three sides of the SPXC units. (see pages 6 & 11)



SPXC Series

Cooling Only

In keeping with its policy of continuous progress and product improvement, First Co. reserves the right to make changes without notice. Maintenance for all First Co. products is available under "Product Maintenance" at www.firstco.com.

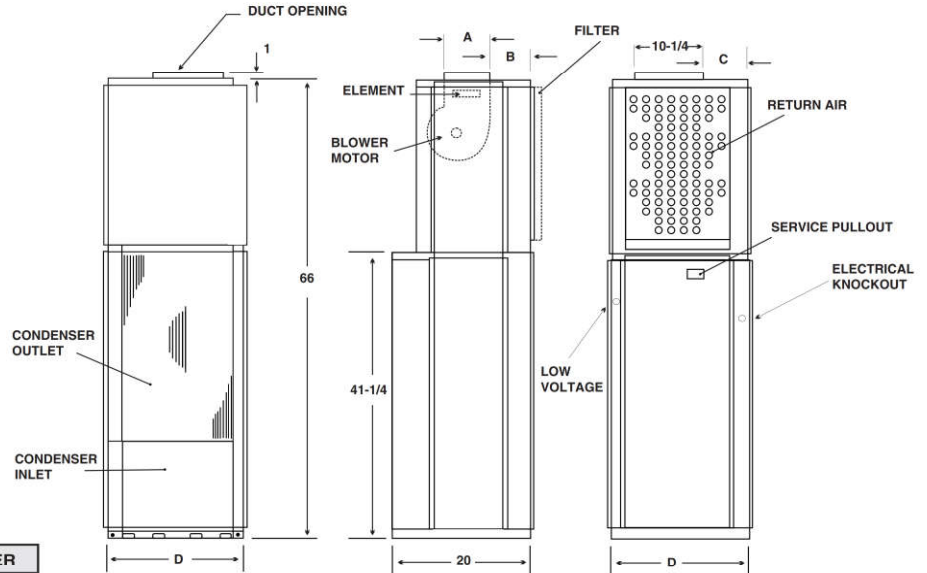

	A	B	C	D	FILTER
9,12,18SPXC	6-1/2	6-1/8	6-5/8	20	18 x 24 x 1
24,30SPXC	10	2-1/2	8	26	24 x 24 x 1

ELECTRICAL DATA (208/230V-1PH-60Hz)																		
UNIT MODEL	ELECTRIC HEAT DATA						BLOWER DATA		CONDENSER DATA				MINIMUM CIRCUIT AMPACITY		MAXIMUM CIRCUIT PROTECTION		SHIP WT.	
	kW		BTUH		TOTAL HEATING AMPS		EVAPORATOR MOTOR		COMPRESSOR		CONDENSER MOTOR							
	240V	208V	240V	208V	240V	208V	AMPS	HP	RLA	LRA	FLA	HP	208V	240V	208V	240V		
9SPXC	-0	0	0	0	0.0	0.0							10	10	15	15	245	
	-2	2	1.5	6800	5100	10.6	9.5	2.3	1/4	4.4	25	2.3	1/4	12	13	15		15
	-3	3	2.25	10200	7700	14.8	13.1							16	18	20		20
	-4	4	3	13600	10200	19.0	16.7							21	23	20		25
12SPXC	-0	0	0	0	0.0	0.0							10	10	15	15	245	
	-2	2	1.5	6800	5100	10.6	9.5	2.3	1/4	4.7	25	2.3	1/4	12	13	15		15
	-3	3	2.25	10200	7700	14.8	13.1							16	18	20		20
	-4	4	3	13600	10200	19.0	16.7							21	23	25		25
	-5	4.5	3.38	15400	11500	21.1	18.6							23	26	25		30
18SPXC	-0	0	0	0	0.0	0.0							16	16	25	25	255	
	-2	2	1.5	6800	5100	11.1	10.0						16	16	25	25		
	-3	3	2.25	10200	7700	15.3	13.6						17	18	25	25		
	-4	4	3	13600	10200	19.5	17.2	2.8	1/3	9.0	56.3	2.3	1/4	22	24	25		25
	-5	4.5	3.38	15400	11500	21.6	19.1							24	26	25		30
	-6	6	4.5	20500	15400	27.8	24.4							31	34	35		35
	-8	8	6.0	27300	20500	36.1	31.6							40	44	40		45
-10	9	6.75	30700	23000	40.3	35.3							44	50	45	50		
24SPXC	-0	0	0	0	0.0	0.0							19	19	25	25	295	
	-3	3	2.25	10200	7700	15.3	13.6						19	19	25	25		
	-4	4	3	13600	10200	19.5	17.2	2.8	1/3	10.9	62.9	2.3	1/4	22	24	25		25
	-5	4.5	3.38	15400	11500	21.6	19.1							24	26	25		30
	-6	6	4.5	20500	15400	27.8	24.4							31	34	35		35
	-8	8	6.0	27300	20500	36.1	31.6							40	44	40		45
-10	9	6.75	30700	23000	40.3	35.3							44	50	45	50		
30SPXC	-0	0	0	0	0	0							22	22	30	30	300	
	-3	3	2.25	10200	7700	16.6	14.9						22	22	30	30		
	-4	4	3	13600	10200	20.8	18.5	4.1	1/2	12.8	67.8	1.9	1/3	23	25	30		30
	-5	4.5	3.38	15400	11500	22.9	20.4							26	28	30		30
	-6	6	4.5	20500	15400	29.1	25.7							32	35	35		35
	-8	8	6.0	27300	20500	37.4	32.9							41	46	45		50
-10	9	6.75	30700	23000	41.6	36.6							46	51	50	60		

BLOWER DATA									
UNIT MODEL	MOTOR SPEED CONN. (1)	CFM vs EXTERNAL STATIC PRESSURE							
		0.05	0.10	0.15	0.20	0.25	0.30	0.35	0.40
9SPXC	HIGH	490	475	465	455	450	440	430	425
	MED (H & C)	390	380	370	360	350	340	330	320
	LOW	320	310	300	290	280	270	260	250
12SPXC	HIGH	500	485	475	465	460	450	445	440
	MED (H & C)	430	420	410	400	390	385	375	370
	LOW	350	340	330	320	310	305	295	285
18SPXC	TAP 3	705	695	685	675	670	660	650	635
	TAP 2(C)	655	645	635	620	610	600	590	580
	TAP 1(H)	565	550	540	530	515	505	490	480
24SPXC	TAP 3	900	890	880	870	860	855	845	835
	TAP 2(C)	820	810	800	790	780	770	760	750
	TAP 1(H)	720	710	700	690	680	670	660	650
30SPXC	TAP 3	910	900	895	890	885	880	875	870
	TAP 2(C)	845	840	835	830	825	820	815	810
	TAP 1(H)	740	730	720	725	715	710	700	690

COOLING / PERFORMANCE DATA		
UNIT MODEL	STANDARD RATING (1)	EER
	BTUH	
9SPXC	9200	11.0
12SPXC	11700	11.0
18SPXC	17600	11.0
24SPXC	22400	11.0
30SPXC	27800	11.0

(1) Tested at 95°F DB/75°F WB outdoors and 80°F DB/67°F WB indoors.

(2) Tested in accordance with AHRI Standard 390.

(1) Factory Settings:

(H) = Heating, (C) = Cooling



SPXC-HP Series

Heat Pump

In keeping with its policy of continuous progress and product improvement, First Co. reserves the right to make changes without notice. Maintenance for all First Co. products is available under "Product Maintenance" at www.firstco.com.



	A	B	C	D	FILTER
9,12,18SPXC-HP	6-1/2	6-1/8	6-5/8	20	18 x 24 x 1
24,30SPXC-HP	10	2-1/2	8	26	24 x 24 x 1

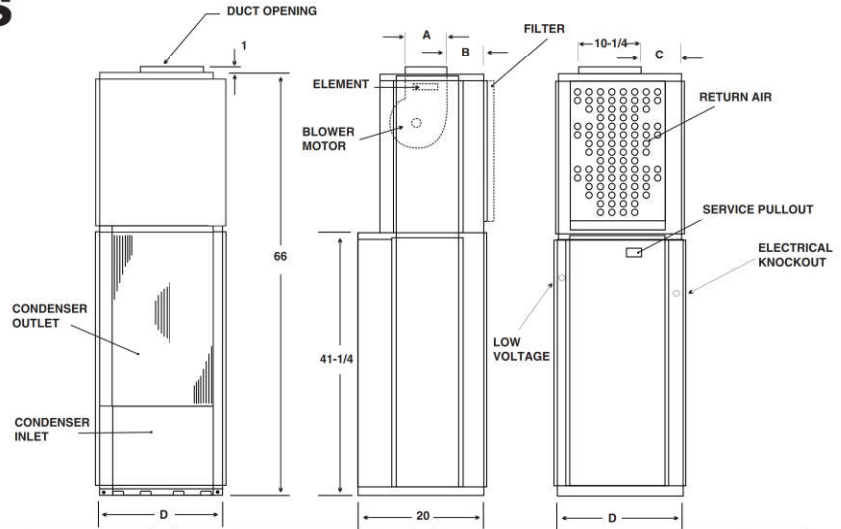

ELECTRICAL DATA (208/230V-1PH-60Hz)																		
UNIT MODEL	ELECTRIC HEAT DATA						BLOWER DATA		CONDENSER DATA				MINIMUM CIRCUIT AMPACITY		MAXIMUM CIRCUIT PROTECTION		SHIP WT.	
	kW		BTUH		TOTAL HEATING AMPS		EVAPORATOR MOTOR		COMPRESSOR		CONDENSER MOTOR		208V	240V	208V	240V		
	240V	208V	240V	208V	240V	208V	AMPS	HP	RLA	LRA	FLA	HP						
9SPXC	-2	2	1.5	6800	5100	10.6	9.5	2.3	1/4	4.4	25	2.3	1/4	12	13	15	15	245
	-3	3	2.25	10200	7700	14.8	13.1							16	18	20	20	
	-4	4	3	13600	10200	19.0	16.7							21	23	25	25	
12SPXC	-2	2	1.5	6800	5100	10.6	9.5	2.3	1/4	4.7	25	2.3	1/4	12	13	15	15	245
	-3	3	2.25	10200	7700	14.8	13.1							16	18	20	20	
	-4	4	3	13600	10200	19.0	16.7							21	23	25	25	
	-5	4.5	3.38	15400	11500	21.1	18.6							23	26	25	30	
	-6	6	4.5	20500	15400	27.8	24.4							31	34	35	35	
18SPXC	-2	2	1.5	6800	5100	11.1	10.0	2.8	1/3	9.0	56.3	2.3	1/4	16	16	25	25	255
	-3	3	2.25	10200	7700	15.3	13.6							17	18	25	25	
	-4	4	3	13600	10200	19.5	17.2							22	24	25	25	
	-5	4.5	3.38	15400	11500	21.6	19.1							24	26	25	30	
	-6	6	4.5	20500	15400	27.8	24.4							31	34	35	35	
	-8	8	6.0	27300	20500	36.1	31.6							40	44	40	45	
	-10	9	6.75	30700	23000	40.3	35.3							44	50	45	50	
24SPXC	-3	3	2.25	10200	7700	15.3	13.6	2.8	1/3	10.9	62.9	2.3	1/4	19	19	25	25	295
	-4	4	3	13600	10200	19.5	17.2							22	24	25	25	
	-5	4.5	3.38	15400	11500	21.6	19.1							24	26	25	30	
	-6	6	4.5	20500	15400	27.8	24.4							31	34	35	35	
	-8	8	6.0	27300	20500	36.1	31.6							40	44	40	45	
	-10	9	6.75	30700	23000	40.3	35.3							44	50	45	50	
30SPXC	-3	3	2.25	10200	7700	16.6	14.9	4.1	1/2	12.8	67.8	1.9	1/3	22	22	30	30	300
	-4	4	3	13600	10200	20.8	18.5							23	25	30	30	
	-5	4.5	3.38	15400	11500	22.9	20.4							26	28	30	30	
	-6	6	4.5	20500	15400	29.1	25.7							32	35	35	35	
	-8	8	6.0	27300	20500	37.4	32.9							41	46	40	50	
	-10	9	6.75	30700	23000	41.6	36.6							46	51	50	60	

NOTE:

Compressors in these models do not operate simultaneously with heater elements.

BLOWER DATA									
UNIT MODEL	MOTOR SPEED CONN. (1)	CFM vs EXTERNAL STATIC PRESSURE							
		0.05	0.10	0.15	0.20	0.25	0.30	0.35	0.40
9SPXC-HP	HIGH	490	475	465	455	450	440	430	425
	MED (H & C)	390	380	370	360	350	340	330	325
	LOW	320	310	300	290	280	270	260	250
12SPXC-HP	HIGH	500	485	475	465	460	450	445	440
	MED (H & C)	430	420	410	400	390	385	375	370
	LOW	350	340	330	320	310	305	295	285
18SPXC-HP	TAP 3	705	695	685	675	670	660	650	635
	TAP 2(C)	655	645	635	620	610	600	590	580
	TAP 1(H)	565	550	540	530	515	505	490	480
24SPXC-HP	TAP 3	900	890	880	870	860	855	845	835
	TAP 2(C)	820	810	800	790	780	770	760	750
	TAP 1(H)	720	710	700	690	680	670	660	650
30SPXC-HP	TAP 3	910	900	895	890	885	880	875	870
	TAP 2(C)	845	840	835	830	825	820	815	810
	TAP 1(H)	740	730	720	725	715	710	700	690

COOLING / PERFORMANCE DATA		
UNIT MODEL	STANDARD RATING (1)	EER
	BTUH	
9SPXC-HP	9100	11.0
12SPXC-HP	11200	11.0
18SPXC-HP	16800	11.0
24SPXC-HP	22200	11.0
30SPXC-HP	27600	11.0

(1) 95°F DB/75°F WB outdoor - 80°F DB/67°F WB indoor.
 (2) Tested in accordance with AHRI Standard 390.

HEATING / PERFORMANCE DATA (3)		
UNIT MODEL	STANDARD RATING (1)	COP (47°)
	BTUH	
9SPXC-HP	8800	3.5
12SPXC-HP	10700	3.3
18SPXC-HP	15700	3.5
24SPXC-HP	20800	3.5
30SPXC-HP	25200	3.3

(1) 47°F DB/43°F WB outdoor, 70°F DB/60°F WB indoor.

WARNING AVERTISSEMENT ADVERTENCIA
 Cancer and Reproductive Harm
 Cancer et Troubles de l'appareil reproducteur
 Cancer y Daño Reproductivo
www.P65Warnings.ca.gov
 LB0997

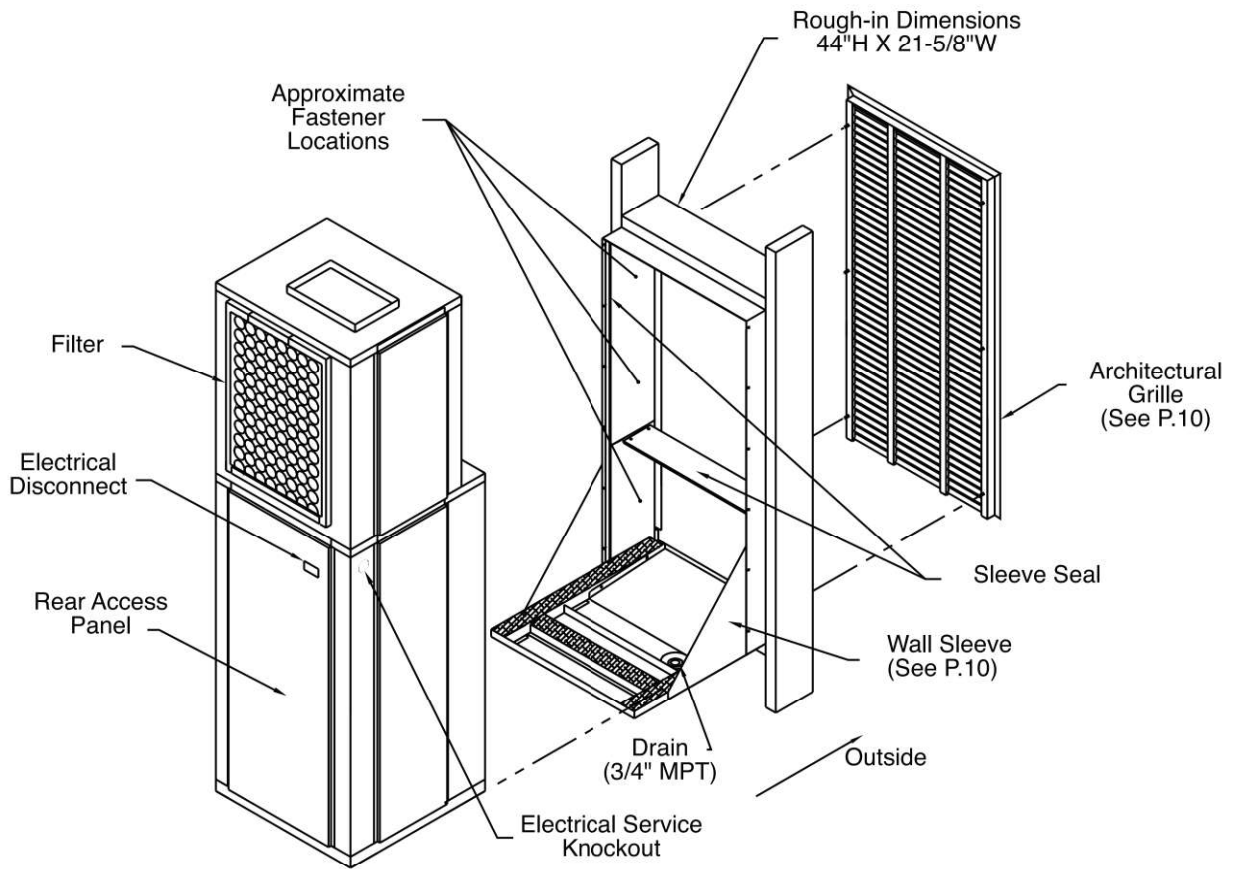

Figure 1 - General Assembly for standard sleeve and Grill

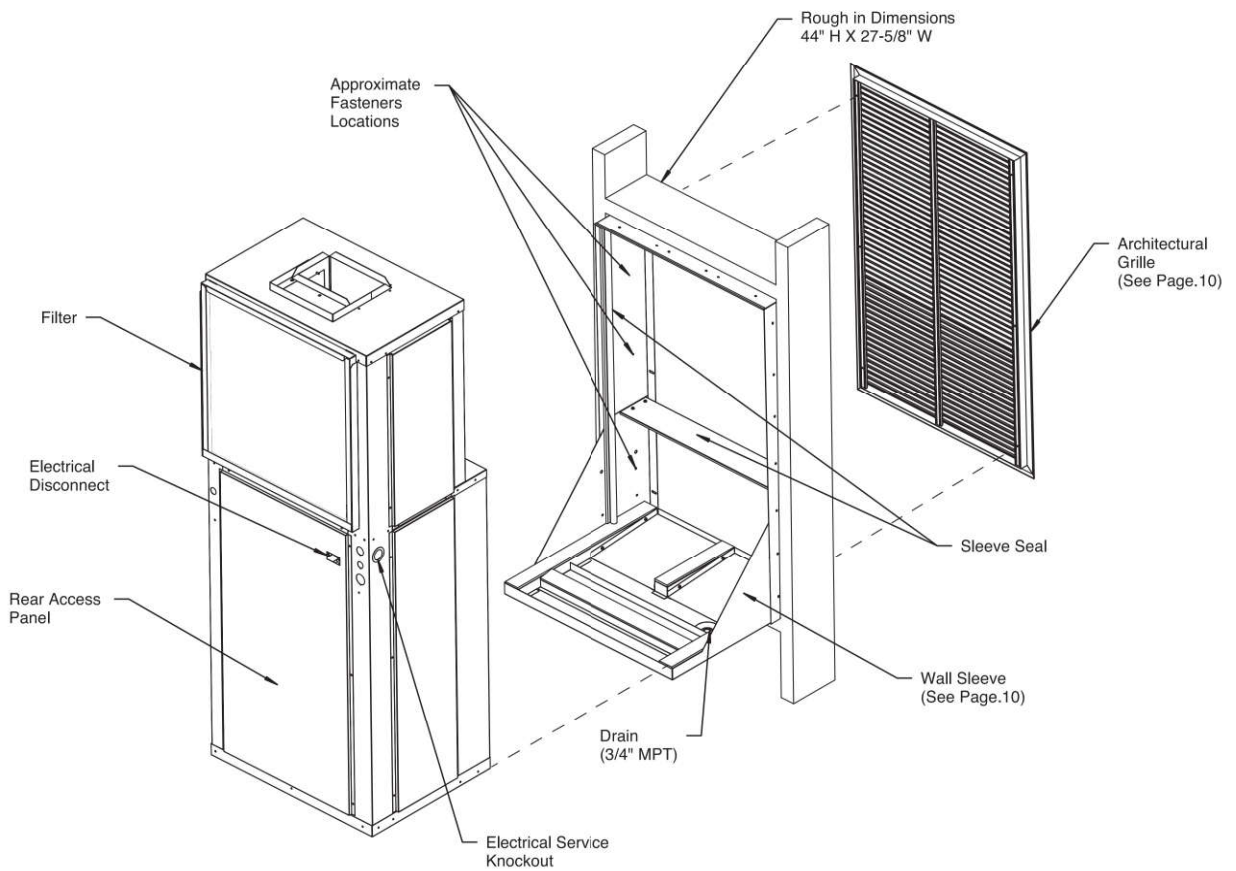

Figure 1A - General Assembly for Large sleeve and Grill size 24

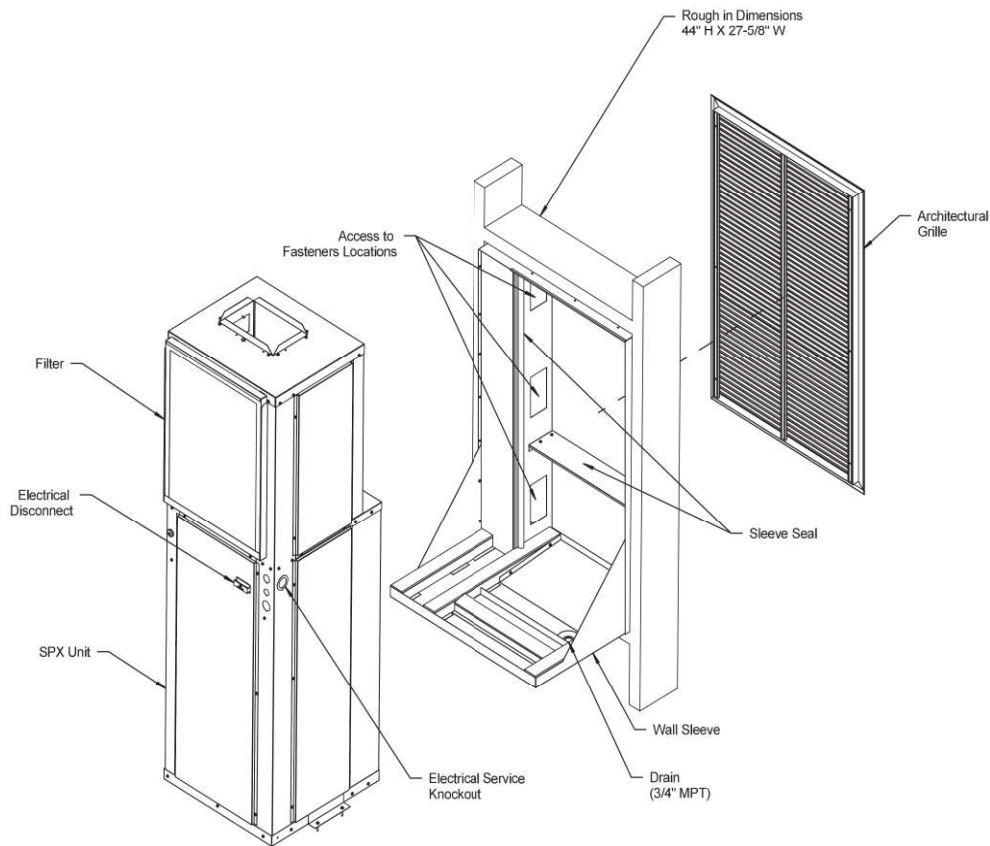

Figure 1B - General Assembly for Large sleeve and Grill for 09-18 sizes with block off

FEATURES AND BENEFITS

1. **Solid State Circuit Board** - Incorporates the following control features:
 - **Evaporator coil low temperature protection** – During the cooling mode, should the evaporator coil experience either a low temperature condition that could result in ice build up on the coil or a reduced air flow situation, a temperature sensor attached to the coil will de-energize the SPXC unit. The sensor will re-energize the SPU unit when the coil warms back up.
 - **Low ambient lockout** – Locks out compressor when the sensor registers temperatures of 40 degrees F and below to extend compressor life.
 - **Random restart** – When power is turned on after a power outage, a built-in random restart (3 to 4 minutes) prevents all compressors from restarting simultaneously.
 - **Compressor restart delay** – This delay ensures that system pressures are allowed to equalize before a compressor restart, which extends compressor life.
 - **Fan delay** – A fan delay allows the evaporator blower to continue running for up to 45 seconds after the thermostat is satisfied. This feature maximizes cooling performance.
 - **Low voltage fuse protection**
2. **Service Pullout** - Factory installed for service convenience and maintenance.
3. **Adjustable fresh air (manual)** - To meet code requirements for fresh air introduction. When opened, the fresh air vent (see Figure 8) allows up to 50 CFM of outside air to be introduced into the equipment closet. The air then mixes with return air entering the closet through the return air grille.
4. **Wall-mounted thermostat** – (See “accessories”, P.11) The SPXC is easily controlled by a standard low voltage wall thermostat rather than complicated unit-mounted controls. Low voltage wires are “stubbed” out the left side of the cabinet.
5. **40VA transformer**

FEATURES AND BENEFITS (CONT.)

5. **Wall Sleeve** – (See Figures 1,1A,1B, 4 and 5) Rear or side install wall sleeves are provided for installation during rough-in and, when ready, the SPXC unit is simply slid into the sleeve and the ductwork and electrical connected. The sleeve is a weight-bearing sleeve that supports the entire weight of the SPXC unit and provides a weather tight seal against wind and water infiltration. A 3/4" male NPT fitting is provided in the bottom of the sleeve for field connection to a condensate riser. Four wall sleeve depths are available to accommodate wall thickness from 5" to 20". Each sleeve includes a factory installed "weather guard" to cover the sleeve opening during construction.
6. **Unique "Sleeve Drain" Condensate System** - (Also see Figure 4) A factory installed drain line connects the evaporator drain pan to a vertical pipe connection in the SPXC base pan. Evaporator condensate is delivered from the SPXC



"Standard Rear Install" sleeve shown

unit to a catch tray in the wall sleeve and exits the sleeve through the 3/4" male NPT fitting. This design allows the plumber to completely pipe the drain to a condensate riser during the rough-in stage, thus eliminating condensate connection problems usually encountered when trying to connect the HVAC drain to the riser after the HVAC unit is installed in the closet. This features also allows the SPXC unit to be removed for service without disconnecting the condensate

pipng! This configuration does not require any additional closet space to make the drain connection, as do some competitive products.

7. **Secondary overflow:** If for any reason the primary condensate riser becomes clogged, water will fill the catch tray and then be diverted through the sleeve to the exterior of the building, rather than be allowed to overflow into the closet or living area. Rain water entering the sleeve is automatically diverted to the 3/4" sleeve drain.
8. **Ductable return air** – Return air can be ducted to the unit. However, most installations would not normally require ducted return air.
9. **New "Flush Style" Architectural Grille** – (See Figure 6) This new grille is an attractive extruded aluminum architectural grille that attaches to the outside face of the wall sleeve. The blades of this unique grille recess into the wall sleeve for a neat, "flush" appearance. Grilles install from the inside of the wall sleeve. Do not install the SPXC unit into the sleeve before installing the grille.
10. **Filter Brackets** – (See Figure 7) Filter Brackets and throw away filter are shipped with each unit and are field installed over the unit's evaporator coil.
11. **Insulation kit (#91K01-91K02)** - The interior of all SPXC's is lined with 1/2" fiberglass as standard. The 91K** kit is designed to be used in any application where additional insulation is desired. The kit includes three sections of 5/8" foil faced ductboard insulation that are screwed together in the field and cover the three sides on the condenser section.

Figure 2



SHOWN WITH OPTIONAL LOUVERED ACCESS PANEL (See P.11)

NOTE: A solid door or panel in front with a side wall return air grill will result in lower sound levels.

Figure 3

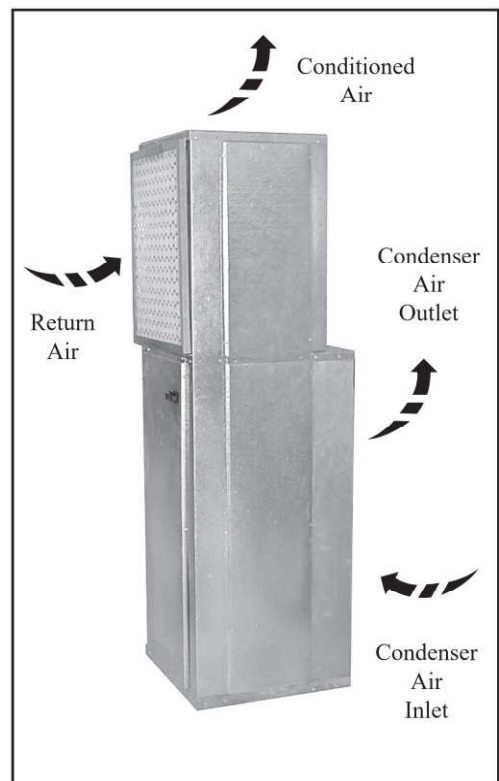

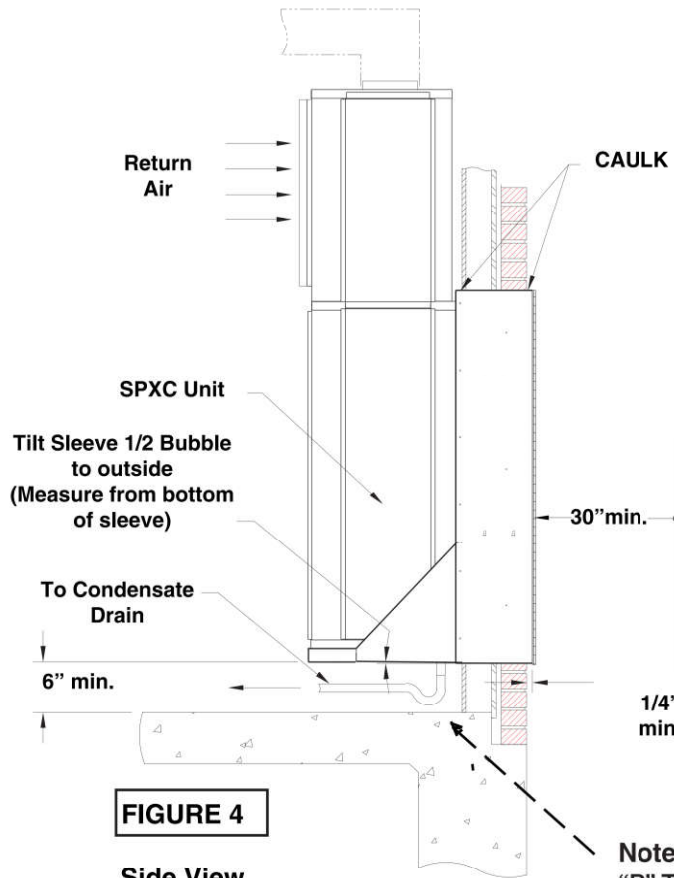

FIGURE 4

**Side View
(with "Rear Install" sleeve)**

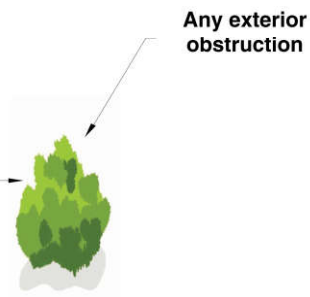

FIGURE 5

Side Install Sleeve

Note:
Separate wall mounting bracket is shipped with "side install" wall sleeves.

Note:
"P" Trap is shown for illustration purposes only - It may not be required by local codes.

UNIT / SLEEVE DIMENSIONS					
Part Number		Fits Wall Thickness	A	B	C
Rear Install	Side Install				
9**-1B	9**-11B	5" - 8" wall	9"	17-1/2"	26"
9**-2B	9**-12B	8" - 12" wall	13"	17-1/2"	30"
9**-3B	9**-13B	12" - 15" wall	16"	17-1/2"	33"
9**-4B	9**-14B	15" - 20" wall	21"	17-1/2"	38"

** = wall sleeve regular, large and large with block off see page 10



FIGURE 6

(Unit shown with "Rear Install" sleeve)

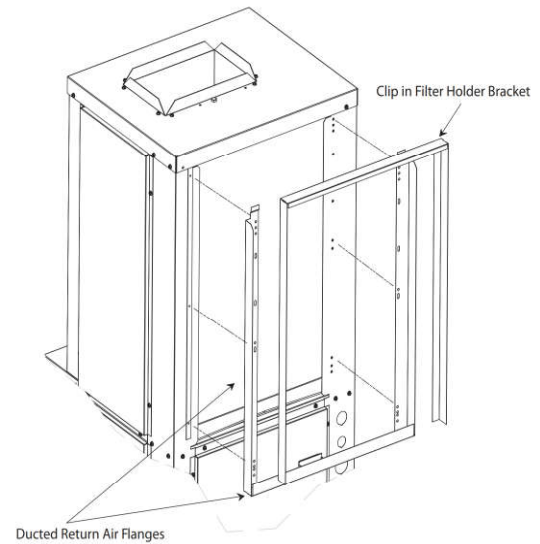
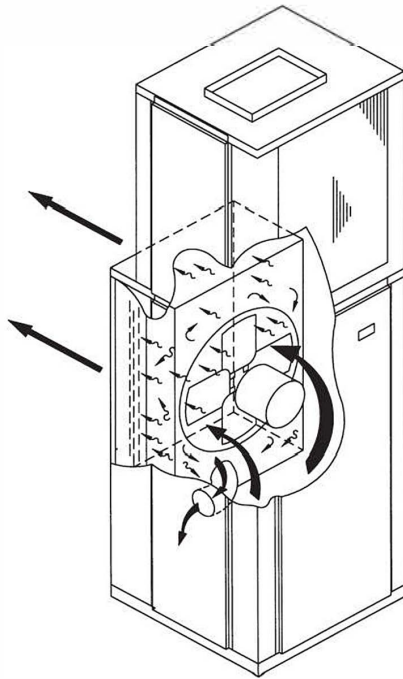

FIGURE 7

Filter Bracket Detail



One end of a 3" aluminum vent pipe is connected to the condenser venturi and the other end is connected to the side of the SPXC cabinet. A mesh screen is installed inside the vent pipe and a metal plate on the side of the cabinet covers the opening of the vent pipe. Up to 50 CFM of fresh air is introduced into the equipment closet by removing the metal cover plate. The fresh air then mixes with the return air and is then pulled through the evaporator coil and into the supply duct. The cover plate can be re-installed to partially close the fresh air opening if less than 50 CFM is desired. An external source of negative pressure (i.e. a bathroom fan) could be used to introduce more than 50 CFM of fresh air. Consult with factory for further details.

FIGURE 8

SPXC Closet Rear Installation Detail for Small Sleeve 21" Wide(9-18SPXC only)

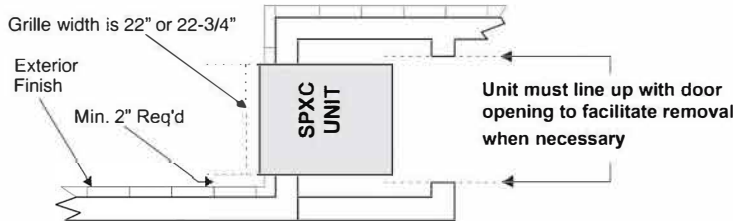

Notes:

1. Sleeve rough-in opening is 44"(H) X 21-5/8"(W).
2. Bottom of opening should be approx. 6" above floor level
3. Minimum 3" of clearance is required on all sides of the SPXC unit.
4. Note the Hurricane Grill is 3/4" larger

SPXC Closet Dimensions - Rear Installation Detail for Small Sleeve 21" Wide (9-18SPXC only)

NOTE:

Provide minimum clearances as shown for interior closet dimensions

Instructions:

To find the minimum closet depth (dimension "C"), use the following method:

Determine dimension "A" which is the total finished wall thickness.

- For 5"-8" outside wall thickness, subtract "A" from 29".
("C" = 29 - "A")
- For 8"-12" outside wall thickness, subtract "A" from 33".
("C" = 33 - "A")
- For 12"-15" outside wall thickness, subtract "A" from 36".
("C" = 36 - "A")

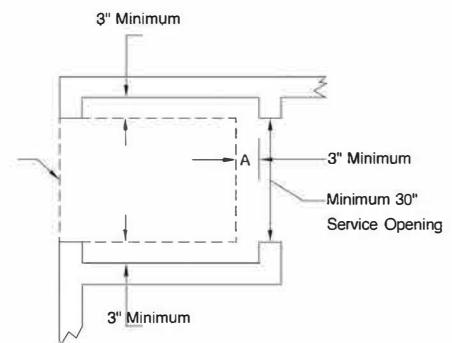

Installed Wall Sleeve
Note: Sleeve dimensions vary based on model purchased

SPXC Closet Rear Installation Detail for Large Sleeve 27" Wide (24 or 30SPXC or 9-18 with Blockoff)

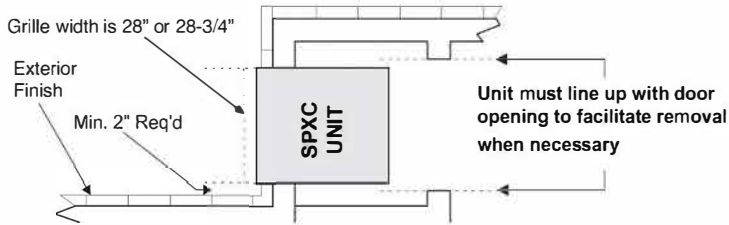

Notes:

1. Sleeve rough-in opening is 44"(H) X 27-5/8"(W).
2. Bottom of opening should be approx. 6" above floor level.
3. Minimum 3" of clearance is required on all sides of the SPXC unit.
4. Note the Hurricane Grill is 3/4" larger

SPXC Closet Dimensions - Rear Installation Detail for Large Sleeve 27" Wide (24SPXC or 9-18 with Blockoff)

NOTE:

Provide minimum clearances as shown for interior closet dimensions

Instructions:

To find the minimum closet depth (dimension "C"), use the following method:

Determine dimension "A" which is the total finished wall thickness.

- For 5"-8" outside wall thickness, subtract "A" from 39".
("C" = 39 - "A")
- For 8"-12" outside wall thickness, subtract "A" from 43".
("C" = 43 - "A")
- For 12"-15" outside wall thickness, subtract "A" from 46".
("C" = 46 - "A")

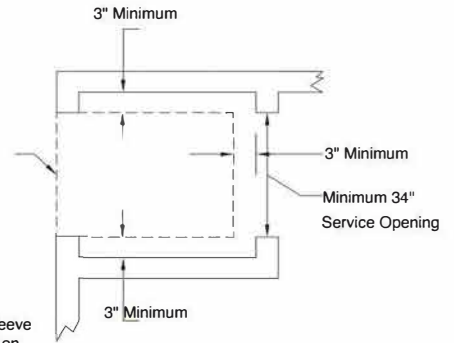

Installed Wall Sleeve
Note: Sleeve dimensions vary based on model purchased

SPXC Closet Dimensions - Side Installation for Small Sleeve 21" Wide (9-18SPXC only)

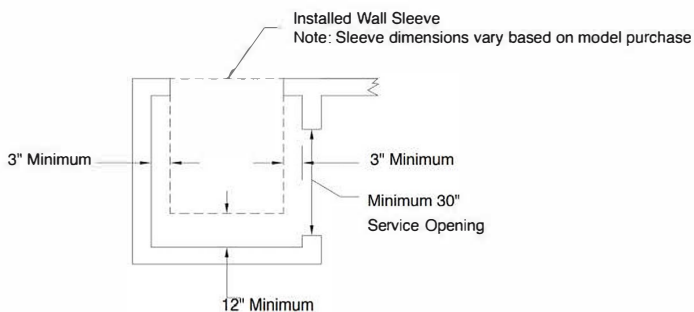

Notes:

1. Sleeve rough-in opening is 44"(H) X 21-5/8"(W).
2. Bottom of opening should be approx. 6" above floor level.
3. Minimum 3" of clearance is required on the sides of the SPXC unit and 12" clearance on the rear of the unit .

NOTE:

Sleeve should be installed in a exterior wall prior to constructing the closet.

SPXC Closet Dimensions - Side Installation for Large Sleeve 27" Wide (24 or 30SPXC or 9-18 with Blockoff)

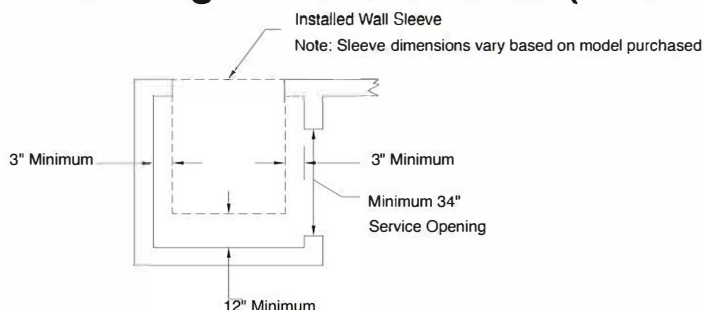

NOTE:

Sleeve should be installed in a exterior wall prior to constructing the closet.

Notes:

1. Sleeve rough-in opening is 44"(H) X 27-5/8"(W).
2. Bottom of opening should be approx. 6" above floor level.
3. Minimum 3" of clearance is required on the sides of the SPXC unit and 12" clearance on the rear of the unit .

ACCESSORIES (sleeves, louver, and thermostat required for each installation)								
ACCESSORY	DESCRIPTION	DIMENSIONS (HXWXD)	PART NUMBERS				SHIP WT. (EA)	
			STANDARD SLEEVES		HURRICANE (5)			
			REAR INSTALL (non-Hurricane)	SIDE INSTALL (3) (non-Hurricane)	REAR INSTALL	SIDE INSTALL	REAR	SIDE
STANDARD WALL SLEEVES SIZE 9-18 (2)	For 5" - 8" thick walls	43-3/4 x 21-3/8 x 26	936-1B	936-11B	936-1H	936-11H	59 (4)	64 (4)
	For 8" - 12" thick walls	43-3/4 x 21-3/8 x 30	936-2B	936-12B	936-2H	936-12H	63 (4)	68 (4)
	For 12" - 15" thick walls	43-3/4 x 21-3/8 x 33	936-3B	936-13B	936-3H	936-13H	68 (4)	73 (4)
	For 15" - 20" thick walls	43-3/4 x 21-3/8 x 38	936-4B	936-14B	936-4H	936-14H	75 (4)	80 (4)
			REAR INSTALL (non-Hurricane)	SIDE INSTALL (3) (non-Hurricane)	REAR INSTALL	SIDE INSTALL	REAR	SIDE
LARGE WALL SLEEVES SIZE 24 & 30 (2)	For 5" - 8" thick walls	43-3/4 x 27-3/8 x 26	985-1B	985-11B	985-1H	985-11H	63 (4)	68 (4)
	For 8" - 12" thick walls	43-3/4 x 27-3/8 x 30	985-2B	985-12B	985-2H	985-12H	68 (4)	73 (4)
	For 12" - 15" thick walls	43-3/4 x 27-3/8 x 33	985-3B	985-13B	985-3H	985-13H	75 (4)	80 (4)
	For 15" - 20" thick walls	43-3/4 x 27-3/8 x 38	985-4B	985-14B	985-4H	985-14H	79 (4)	84 (4)
			REAR INSTALL (non-Hurricane)	SIDE INSTALL (3) (non-Hurricane)	REAR INSTALL	SIDE INSTALL	REAR	SIDE
LARGE WALL SLEEVES WITH BLOCK OFF SIZE 9-18 (2)	For 5" - 8" thick walls	43-3/4 x 27-3/8 x 26	986-1B	986-11B	986-1H	986-11H	63 (4)	68 (4)
	For 8" - 12" thick walls	43-3/4 x 27-3/8 x 30	986-2B	986-12B	986-2H	986-12H	68 (4)	73 (4)
	For 12" - 15" thick walls	43-3/4 x 27-3/8 x 33	986-3B	986-13B	986-3H	986-13H	75 (4)	80 (4)
	For 15" - 20" thick walls	43-3/4 x 27-3/8 x 38	986-4B	986-14B	986-4H	986-14H	79 (4)	84 (4)
			REAR INSTALL (non-Hurricane)	SIDE INSTALL (3) (non-Hurricane)	REAR INSTALL	SIDE INSTALL	REAR	SIDE
ARCHITECTURAL GRILLES STANDARD			Custom Painted	For Field Painting	Anodized Aluminum			
	Standard	44 x 22	G205S (1)	G205PPA	G205A	---	12	
	Hurricane	45-5/8 x 22-3/4	G215S (1)	G215P	G215A	---	22	
ARCHITECTURAL GRILLES LARGE			Custom Painted	For Field Painting	Anodized Aluminum			
	Standard	44 x 28	G216S (1)	G216PPA	G216A	---	18	
	Hurricane	45-5/8 x 28-3/4	G217S (1)	G217P	G217A	---	28	

NOTES:

- (1) "S" indicates custom color, to be provided by customer. Minimum order quantity is 20 per color.
- (2) Rear install application provides better access to the SPXC unit and is recommended over "side install" wherever possible.
- (3) Side install application requires different closet size and configuration. (See P.9) Contact factory for further information.
- (4) All wall sleeves are shipped two (2) per carton.
- (5) Hurricane sleeves require special grille (see "Architectural Grilles" above) (contact the factory for information about hurricane sleeves and grilles)

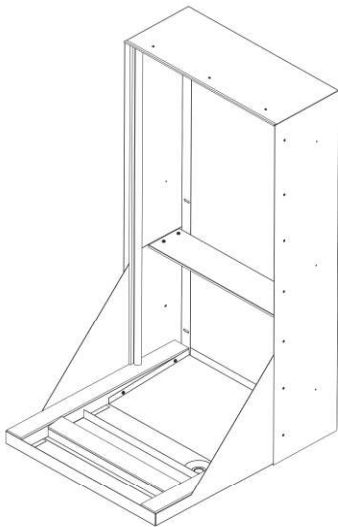



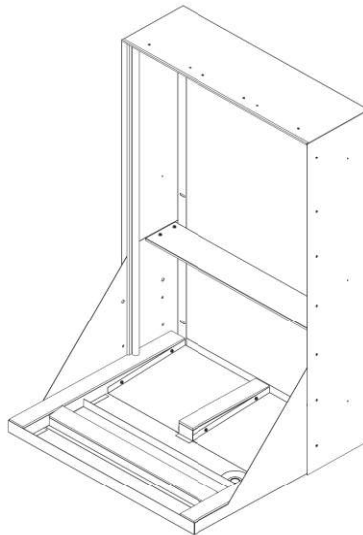

Standard sleeve for 9SPXC, 12SPXC and 18SPXC

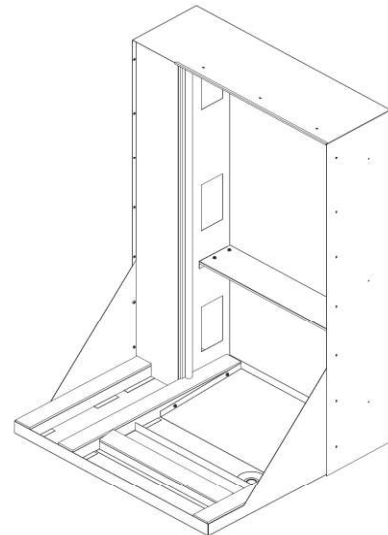

Standard sleeve for 24 or 30SPXC (large)



Large sleeve for 9SPXC, 12SPXC and 18SPXC If Larger Grille is needed to match exterior

THERMOSTATS	Straight Cool (24V) Digital cool - off - heat, auto - on w/limits-(6-wire)	4 x 5 (Horizontal)	T1020NC		---	---
	Heat Pump (24V) Digital w/emergency heat cool - off - heat, auto - on w/limits-(6-wire)	4 x 5 (Horizontal)	T1220NC		---	---
	Programmable (5-2) st. Cool/Ht. Pump (24V) cool-off-heat, auto-on w/em. Ht. & limits (6-wire)	4 x 5 (Horizontal)	T2220NC		---	---
	Straight Cool or Heat Pump (24V) Digital Occupancy Sensor	4.3 x 5.7 (Horizontal)	T8532		New!	

OPTIONAL ACCESSORIES (field installed)					
COMPONENT	DESCRIPTION	DIMENSIONS (H X W)		PART NUMBER	SHIP WT.
		FRAME	OPENING		
ACCESS / RETURN AIR PANEL (3)(4)	LOUVERED (1)	87 X 31	84 X 28	931-11	55
	NON-LOUVERED (2)	87 X 31	84 X 28	931-12	
	LOUVERED (1)	82 X 31	79 X 28	931-13	55
	NON-LOUVERED (2)	82 X 31	79 X 28	931-14	
ACCESS / RETURN AIR PANEL (3)(4)	LOUVERED (1)	87 X 37	84 X 34	931-15	55
	NON-LOUVERED (2)	87 X 37	84 X 34	931-16	
	LOUVERED (1)	82 X 37	79 X 34	931-17	55
	NON-LOUVERED (2)	82 X 37	79 X 34	931-18	
9-18 INSULATION KIT	5/8" DUCTBOARD	N/A		91K01	---
24 INSULATION KIT				91K02	---

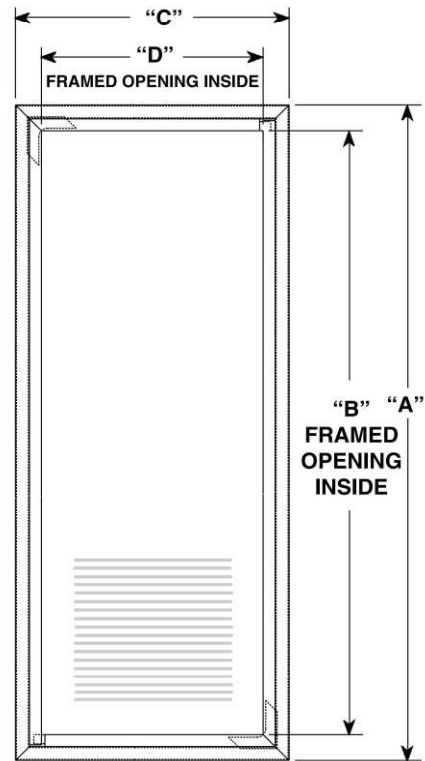

PART NO.	"A"	"B"	"C"	"D"
931-11(12)	87.00	84.00	31.00	28.00
931-13(14)	82.00	79.00	31.00	28.00
* 931-15(16)	87.00	84.00	37.00	34.00
* 931-17(18)	82.00	79.00	37.00	34.00



91K01 OR 91K02

* For rear installation use with size 24 or 30

NOTE: A solid door or panel with a side wall return air grille will result in lower sound levels.

NOTES:

- (1) Includes 18 x 24 x 1 or 20 x 24 x 1 filter.
- (2) Requires external return air grille and unit mount filter.
- (3) Both panels are insulated for sound reduction and have tamperproof screws.
- (4) Panels are shipped ten per carton.

MODEL NUMBER NOMENCLATURE

