

Installation, Operation, & Maintenance

IOM 8511
Rev. B 03/26

EFE, EFW SERIES Space Constrained Unit w/ Hot Water or Electric Heat & Energy Recovery Ventilation

ecoseries
FRESH-PAK[®]

ATTENTION:

Read all instructions thoroughly and retain all manuals for future reference.

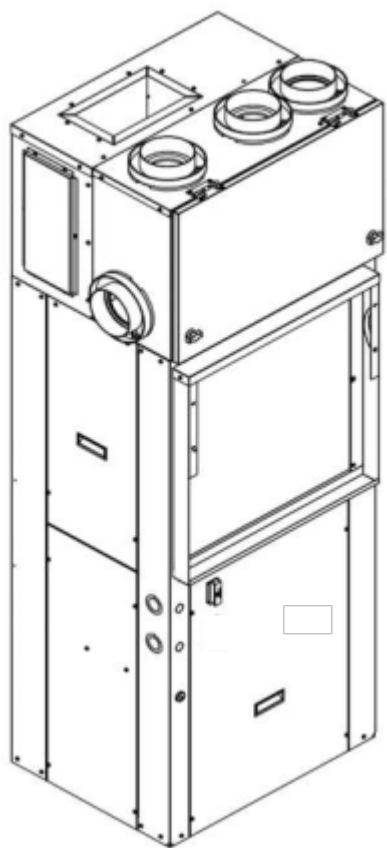

COPYRIGHT

The Manufacturer works to continually improve its products and as a result, it reserves the right to change design and specifications without notice.

The warranty may be void unless the Startup & Performance Checklist is completed and returned to the warrantor. If the FRESH-PAK unit is not installed properly the warranty will be void as the manufacturer cannot be held accountable for problems that stem from improper installation.



WARNING



This appliance is not to be used by persons (including children) with reduced physical, sensory or mental capabilities, or lack of experience and knowledge, unless they have been given supervision or instruction concerning use of the appliance by a person responsible for their safety

Children should be supervised to ensure that they do not play with the appliance

Use adequate personal protection equipment when installing and performing maintenance. After switching off and locking-out an electrical disconnect, verify a safe condition with an electrical tester. Discharge a capacitor before handling any PSC motor and wiring. Use eye protection, cut resistant gloves and sleeves to protect against metal edges and screws.

Do not alter this product by using non-authorized parts. Such action voids all warranties or implied warranties and may result in adverse operation and performance and may be hazardous to service personnel and occupants. Company employees and/or contractors are not authorized to waive this warning.



TABLE OF CONTENTS

| | |
|---------------------------------|-------|
| SAFETY CONSIDERATIONS | 4 |
| MODEL NOMENCLATURE | 5 |
| GENERAL INFORMATION | 6 |
| UNIT OPERATION | 7 |
| STORAGE | 7 |
| SHIPPING & PACKAGE LIST | 8 |
| UNIT INSPECTION LIST | 9 |
| UNIT DIMENSIONAL DATA EFE | 10-11 |
| UNIT DIMENSIONAL DATA EFW | 12-13 |
| HOT WATER OUTLETS EFW | 14 |
| UNIT PHYSICAL DATA EFE | 15 |
| UNIT PHYSICAL DATA EFW | 16 |
| ELECTRICAL DATA | 17-18 |
| INSTALLATION | 19-29 |
| ELECTRICAL | 30 |
| CONTROLS | 31-40 |
| BLOWER DATA | 41-42 |
| FIELD ERV ACCESSORIES | 43-45 |
| LOCATION OF MAJOR COMPONENTS | 46 |
| WIRING DIAGRAMS | 47-50 |
| CIRCUIT SCHEMATIC | 51 |
| STARTUP INSTRUCTIONS | 52-54 |
| STARTUP & PERFORMANCE CHECKLIST | 54 |
| TROUBLESHOOTING | 55-56 |
| ERV ALARM CODES | 57-61 |
| OPERATION & MAINTENANCE | 62-68 |
| PERFORMANCE TABLES | 69 |
| SUPPORT MATERIAL | 70 |
| STARTUP & PERFORMANCE CHECKLIST | 71-72 |
| NOTES | 73 |



SAFETY CONSIDERATIONS

1. READ THE ENTIRE MANUAL BEFORE STARTING THE INSTALLATION.
2. These instructions are intended as a general guide and do not supersede national, state, or local codes in any way.
3. Altering the product, improper installation, or the use of unauthorized factory parts voids all warranty or implied warranty and may result in adverse operation and/or performance or may result in hazardous conditions to service personnel and occupants. Company employees or contractors are not authorized to waive this warning.
4. This product should only be installed and serviced by a qualified, licensed, and factory authorized installer or service agency.
5. All “kits”, parts, and “accessories” used must be factory authorized when modifying this product. Refer and follow instructions packaged with the kits or accessories when installing.



RECOGNIZE THE FOLLOWING SAFETY NOTATIONS THROUGHOUT THIS MANUAL AND POSTED ON THE EQUIPMENT:



 **WARNING** 

Indicates a potentially hazardous situation or unsafe practices that could result in severe personal injury or death and/or damage to property.



 **NOTE** 



Used to highlight suggestions, which may result in enhanced installation, reliability or operation.

 **WARNING** 

 **ELECTRIC SHOCK HAZARD** 

Signifies potential electrical shock hazards that could result in personal injury or death.

 **WARNING** 

 **FIRE OR EXPLOSION HAZARD** 

Failure to follow safety warnings exactly could result in property damage, dangerous operation, serious injury, or death. Improper servicing could result in dangerous operation, serious injury, death, or property damage.

- Before servicing, disconnect all electrical power to the unit.
- When servicing controls, label all wires prior to disconnecting. Reconnect wires correctly.

Verify proper operation after servicing

 **CAUTION** 

Indicates a potentially hazardous situation that may result in minor or moderate personal injury.

 **IMPORTANT** 

Suggests important procedure steps to insure proper installation, reliability, or operation.

MODEL NOMENCLATURE

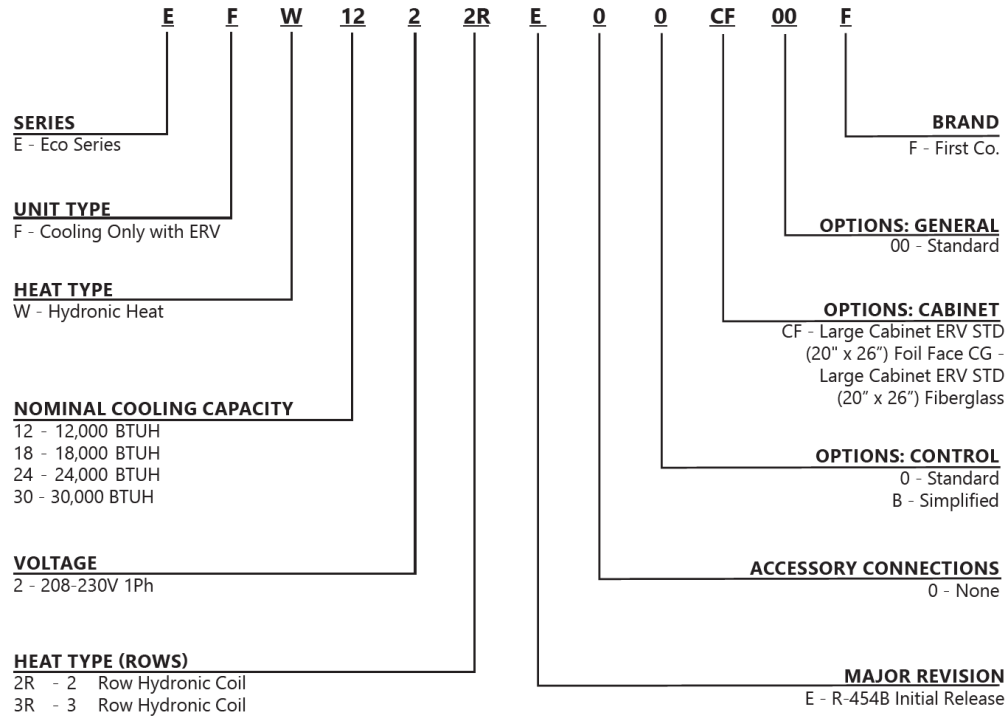
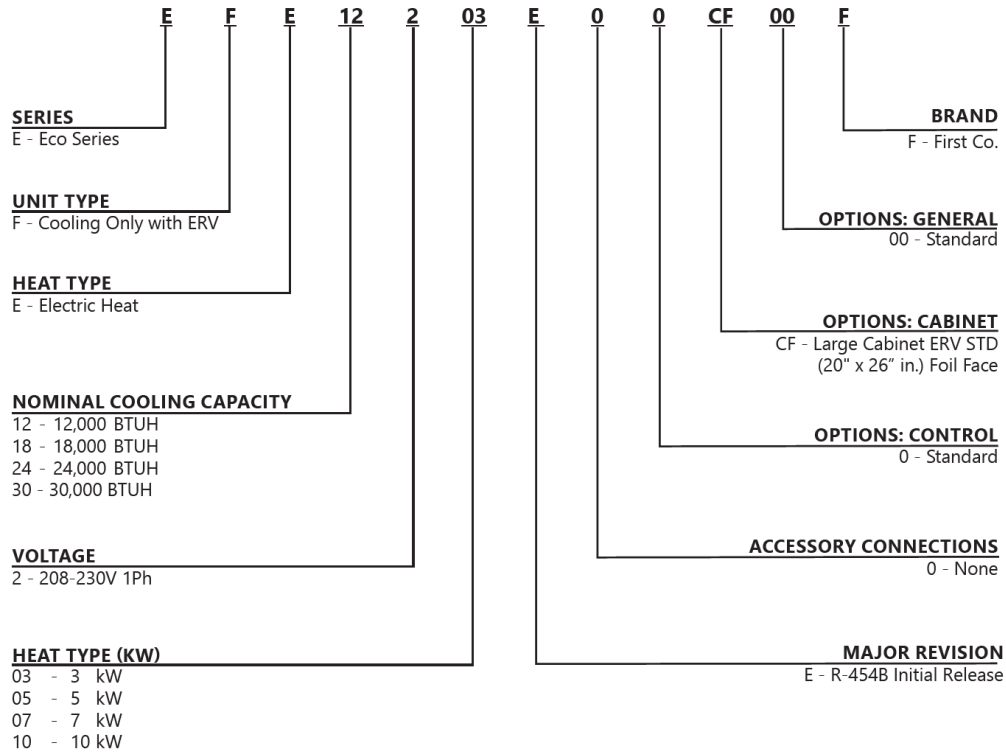



FIGURE 1 - Model Nomenclature



GENERAL INFORMATION





The FRESH-PAK unit is a combination of our high efficiency, high performance and reliable vertically packaged unit with an integral Energy Recovery Ventilation (ERV) System. ERVs provide pre-conditioned fresh outdoor air to your space either directly or through the normal return of your air handling unit. The benefits include improved indoor air-quality, reduced energy costs and lower first cost of installation. The FRESH-PAK EFE/EFW models come standard with ECM blowers for high efficiency and comfort and features and optional electric or hydronic heating. All FRESH-PAK models are certified to AHRI Standard 210/240-2020 and are compliant with UL60335-2-40.



These instructions are given for the installation of the Eco Series Fresh-Pak EFE and EFW models specifically. For any other related equipment, refer to the appropriate manufacturer's instructions.

This unit may be installed at altitudes up to 10,000 ft. (3,048 m).

| | | |
|--------------------------------------------------------------------------------------------------------------------------------------------------------------------------------------------------------------------------------|----------------|------------------------------------------------------------------------------------|
|  | WARNING |  |
| This unit is certified for through-the-wall indoor installation only. It is NOT approved for mobile homes, recreational vehicles or outdoor applications. Such use could result in property damage, personal injury, or death. | | |



| | | |
|---------------------------------------------------------------------------------------------------------------------------------------------------------------------------------------------------------------------------------------|------------------|-------------------------------------------------------------------------------------|
|  | IMPORTANT |  |
| Do not operate this unit in any mode during building construction due to excessive airborne dust and debris. Do not operate this unit without an air filter in place. The manufacturer does not warrant equipment subjected to abuse. | | |

| | | |
|-----------------------------------------------------------------------------------------------------------------------------------------------------------------------|------------------------------|-------------------------------------------------------------------------------------|
|  | WARNING |  |
|  | ELECTRIC SHOCK HAZARD |  |
| Before servicing equipment, ALWAYS turn off all power to the unit. There may be more than one disconnect switch. Electrical shock can cause injury or death | | |

| | | |
|-------------------------------------------------------------------------------------------------------------------------------------------------------------------------------------------------------------------------|-------------|-------------------------------------------------------------------------------------|
|  | NOTE |  |
| Material in this shipment has been inspected at the factory and released to the transportation agency in good condition. | | |
| Upon receipt, a visual inspection of all cartons should be made immediately. Any evidence of rough handling or apparent damage should be noted on the delivery receipt in the presence of the carrier's representative. | | |
| If damage is found, a claim should be immediately filed against the carrier. | | |

| | | |
|-----------------------------------------------------------------------------------------------------------|----------------|-------------------------------------------------------------------------------------|
|  | WARNING |  |
| Take extreme caution that no internal damage will result if screws or holes are drilled into the cabinet. | | |

| | | |
|-------------------------------------------------------------------------------------|----------------|---------------------------------------------------------------------------------------|
|  | CAUTION |  |
| Do not operate this unit without an air filter in place. | | |

| | | |
|-------------------------------------------------------------------------------------------------------------------------------------------|-------------|---------------------------------------------------------------------------------------|
|  | NOTE |  |
| Remove shrink-wrap and all packaging materials before installation. Ensure louvered areas are free from obstructions before installation. | | |

UNIT OPERATION



IMPORTANT



The unit is designed to operate at maximum 0.5 in.w.c external static pressure. Operation at higher E.S.P may cause equipment failure. For applications requiring higher static operation, please contact factory or the manufacture’s sales representative.



WARNING



These instructions are intended as an aid to qualified, licensed, service personnel for proper installation, adjustment and operation of this unit. Read these instructions thoroughly before attempting installation or operation. Failure to follow these instructions may result in improper installation, adjustment, service or maintenance possibly resulting in fire, electrical shock, property damage, personal injury or death.

| Unit Operating Range °F [°C] | | |
|------------------------------|-----------|------------|
| Condition | Cooling | |
| | Min | Max |
| Outdoor DB | 60 [15.6] | 115 [46.1] |
| Indoor DB | 60 [15.6] | 90 [32.2] |

Table 1 – Unit Operating Range

Note:

- 1) Operating ranges based off standard installation with “0” external static and standard Louvers. Operation with non-standard louvers may lower unit operating range.

STORAGE

Equipment should be stored in a clean dry, conditioned area with maximum temperatures up to 120°F [48.89°C] and minimum temperatures to 32°F [0°C]. Units should be stored upright and in an indoor environment. It is recommended to leave packaging on the unit until the installation is to begin.



WARNING



REFRIGERANT UNDER PRESSURE

Units are factory charged with refrigerant. Store units in a location that will minimize the potential for damage. Do not store the unit where sources of ignition are continuously present.

Do not use means to accelerate the defrosting process, or to clean the unit, other than those recommended by the manufacturer.

Be aware that refrigerants may not contain an odour.

Do not pierce or burn.



WARNING



DO NOT stack FRESH-PAK units!. Failure to follow these instructions may result in property damage, personal injury or death.



WARNING



Do not operate this unit in any mode during building construction due to excessive airborne dust and debris. Do not operate this unit without an air filter in place. The manufacturer does not warrant equipment subjected to abuse.

SHIPPING & PACKAGING LIST

SHIPPING INSTRUCTIONS

FRESH-PAK units must remain in the upright position throughout the shipping and handling process to maintain the proper compressor oil level.

PACKAGE LIST

The units will be shipped with the following. Quantities listed in Paratheses.

1. FRESH-PAK Package DX Cooling Unit with Integral ERV
 - a. Shipping brackets (2)
 - b. Screws (4)
 - c. Mounting bracket (2)
 - d. Screws (4)
2. Literature Package containing
 - a. IOM - Installation & Operations Manual (1)
3. Duct Collar Kit
 - a. ERV Round Duct Connections (4)
 - b. Screws (12)

Check the unit for shipping damage; if damage is found, immediately contact the last carrier.

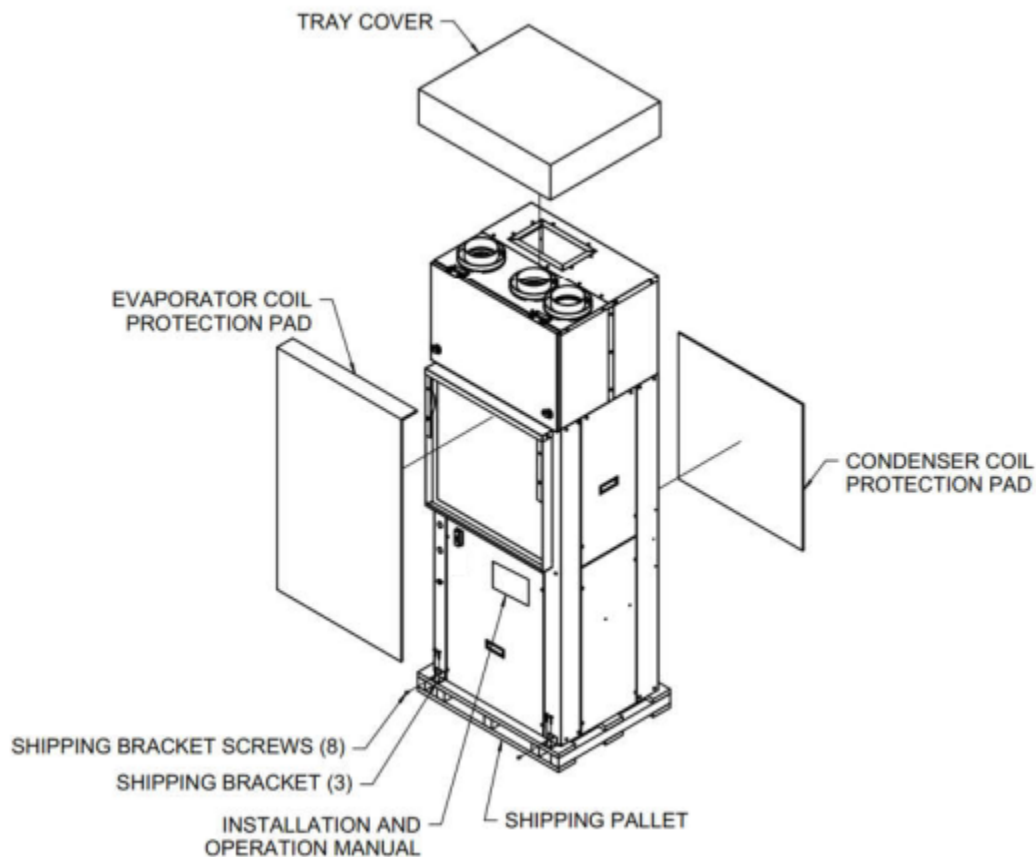

FIGURE 2 - Standard Packaging

UNIT INSPECTION CHECKLIST

Before preparing unit for installation, complete the inspection procedures below.

- 1) Visually inspect unit for any shipping damage. Damage must be reported immediately to the shipping company to make a claim.
- 2) Ensure that the carrier makes proper notation of any shortages or damage on all copies of the freight bill and completes a common carrier inspection report.
- 3) Verify that unit nameplates on the data label match the sales order or bill of lading (including, unit configuration, size and voltage).
- 4) Immediately before installation, remove unit front panel and verify that all electrical connections are tight and that there are no loose wires.
- 5) Verify that the refrigerant piping is free from any kinks and there is no interference between unit piping and sheet metal or electrical wires.
- 6) Remove the blower access panel and remove the foam packaging mount underneath the blower.
- 7) Check that the blower spins freely within the housing and there are no obstructions between the wheel and housing. The wheel can sometimes come loose in shipping.
- 8) Ensure that evaporator distributor tubes are not touching one another and that they are over the drain pan.
- 9) Check the air-coil fins for any damage during shipping.
- 10) Ensure that shipping brackets and screws are removed from condensing section. Refer to **FIGURE 3 - Standard Packaging with Brackets – Front View** & **FIGURE 4 - Standard Packaging with Brackets – Back View** for more information.

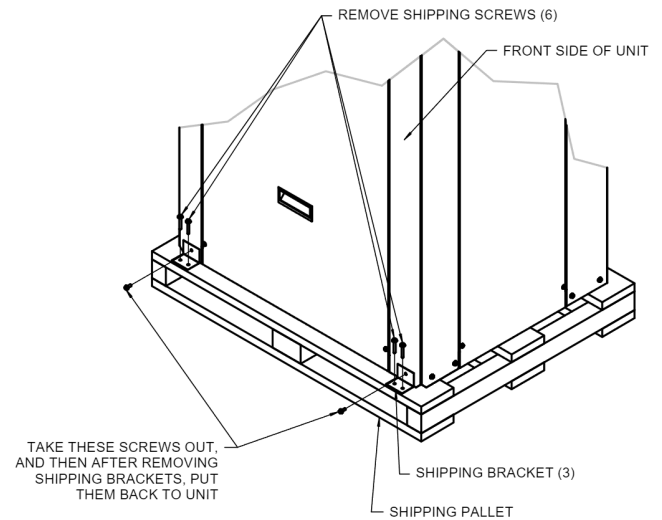

FIGURE 3 - Standard Packaging with Brackets – Front View

| | | |
|---------------------------------------------------------------------------------------------------------------------------------------------------------------------------------------------------|-------------|----------|
| i | NOTE | i |
| <p>Check the unit nameplate for correct voltage with the plans before installing the equipment.</p> <p>Ensure that all electrical ground, connections are made in accordance with local code.</p> | | |

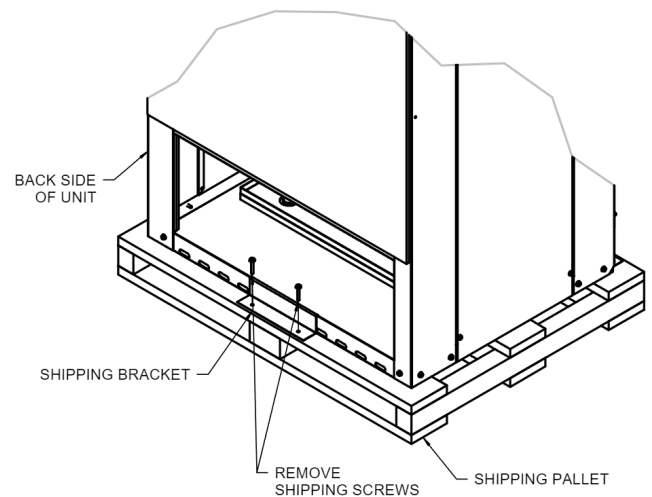

FIGURE 4 - Standard Packaging with Brackets – Back View

UNIT DIMENSIONAL DATA EFE

Unit Dimensions
12K

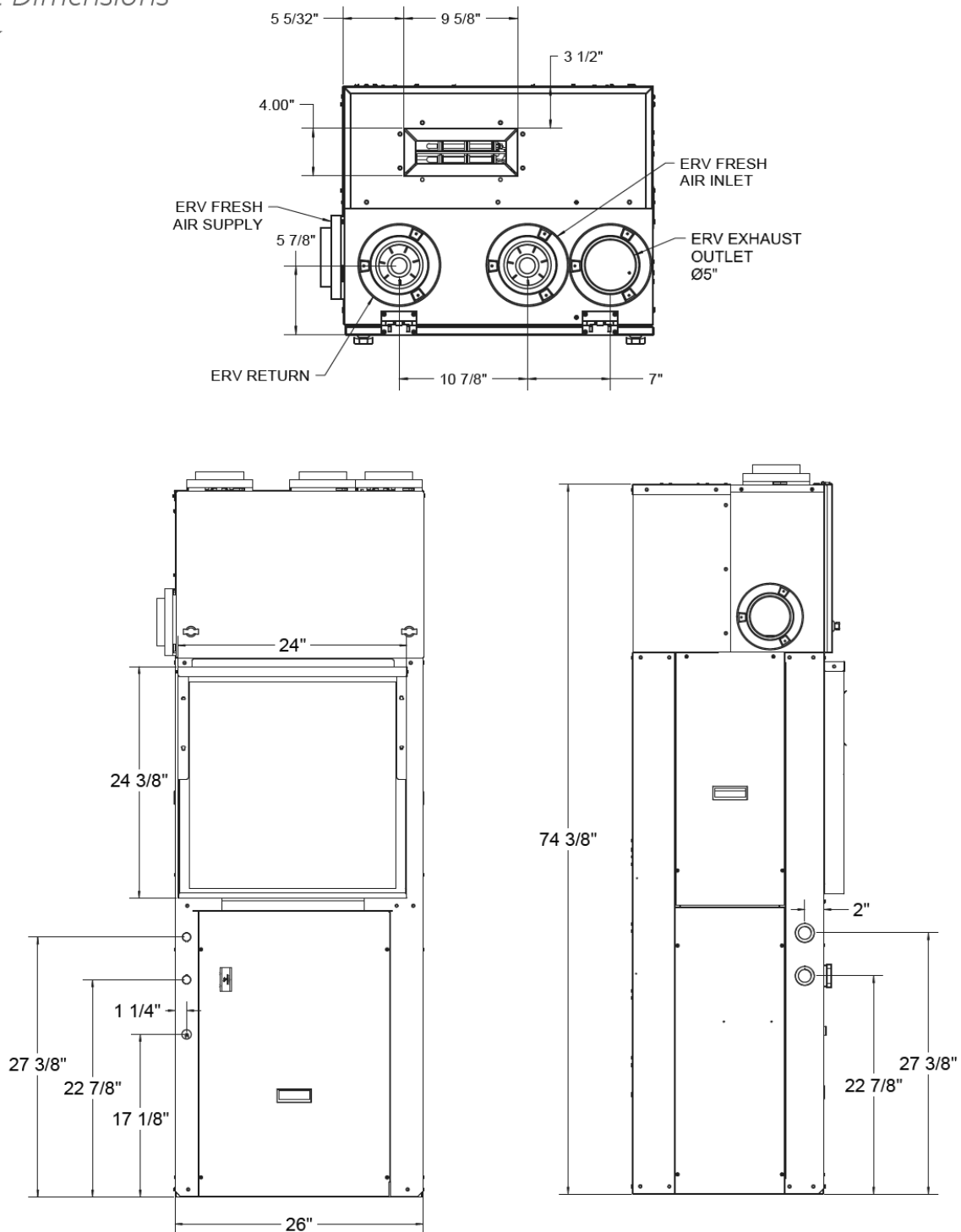

Figure 5- EFE Unit Dimensions 12K

UNIT DIMENSIONAL DATA EFE

Unit Dimensions
18-30K

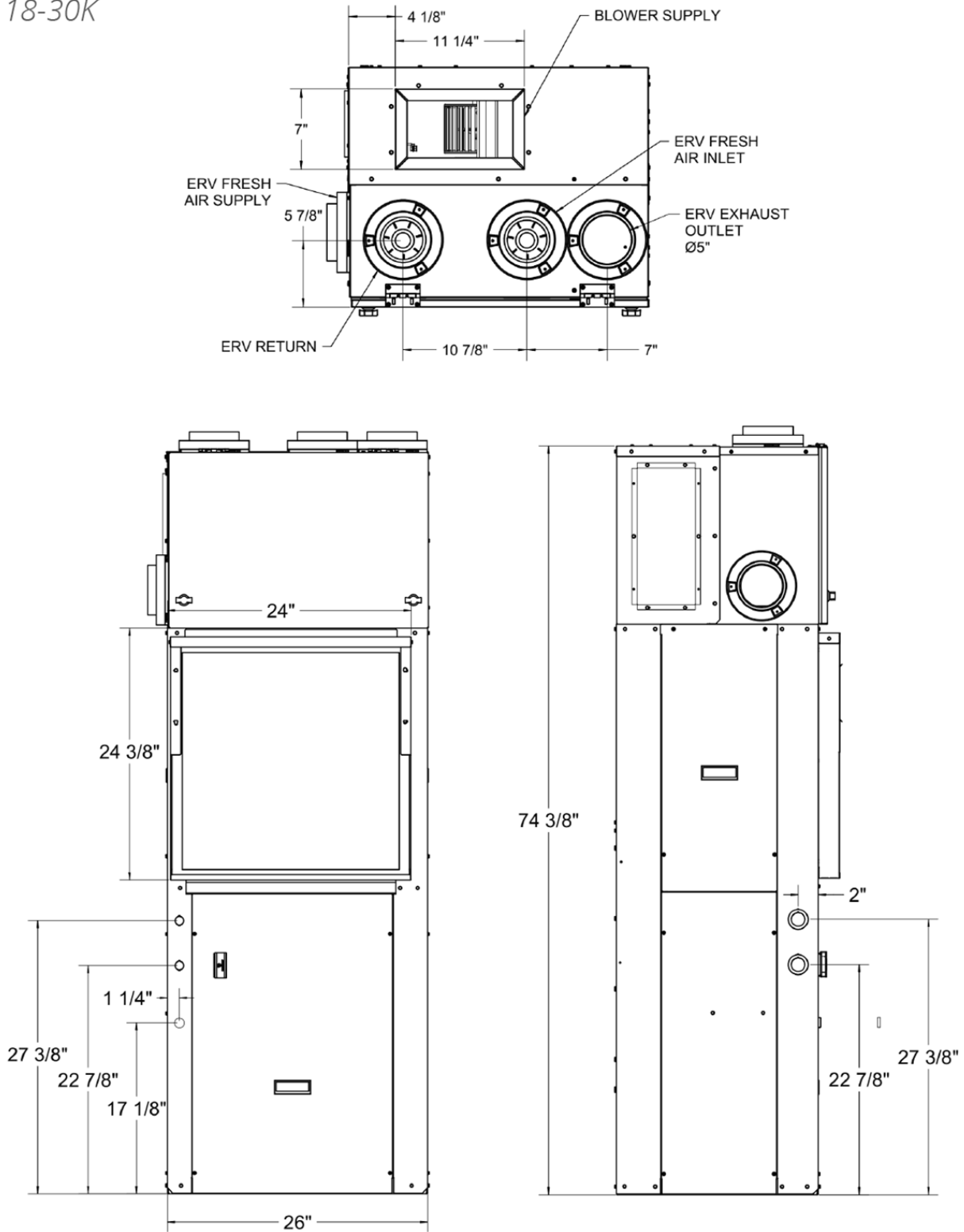

Figure 6 - EFE Unit Dimensions 18-30K

UNIT DIMENSIONAL DATA EFW

Unit Dimensions

12K

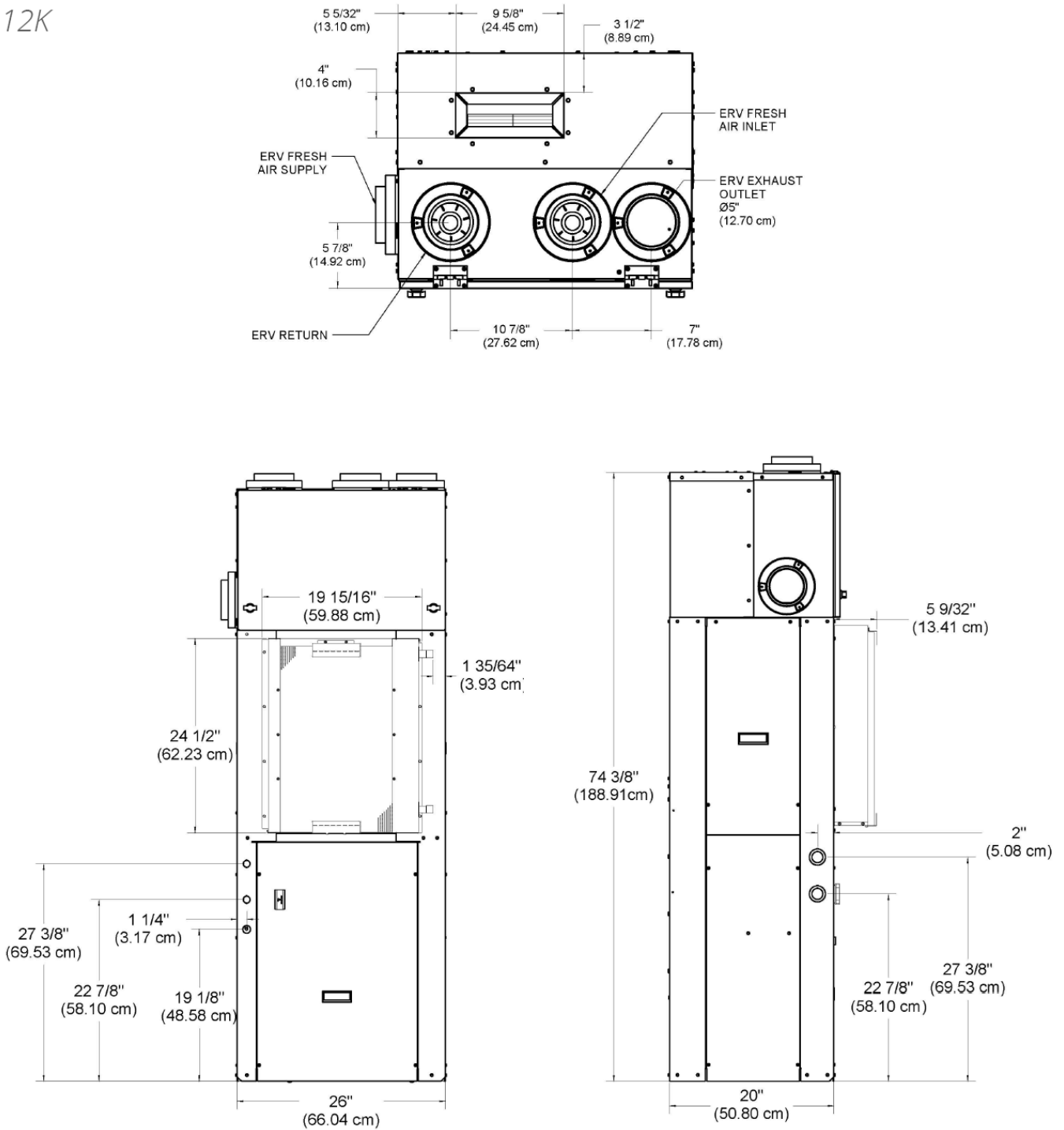

Figure 7 - EFW Unit Dimensions 12K

UNIT DIMENSIONAL DATA EFW

Unit Dimensions 18-30K

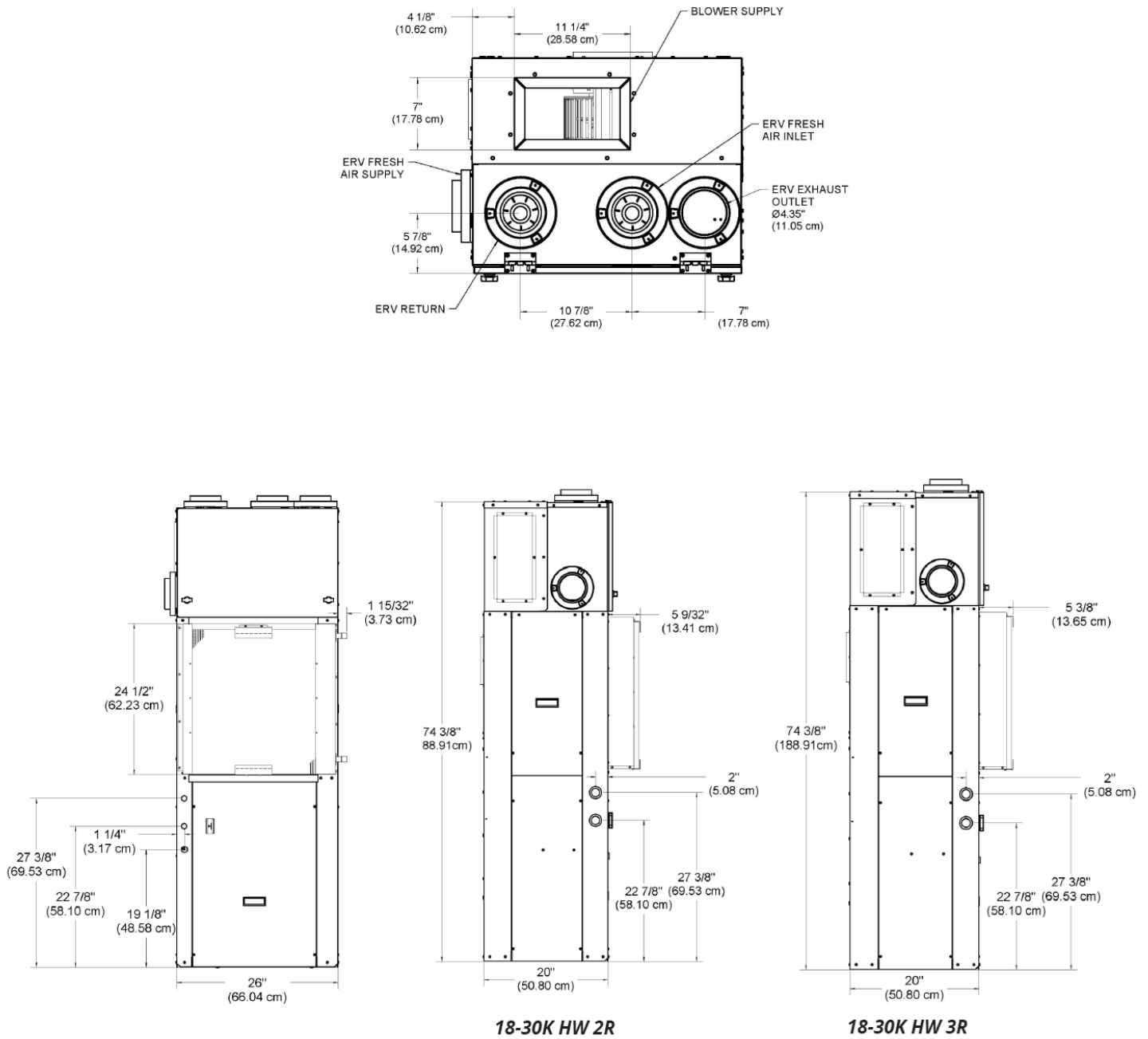

Figure 8 - EFW Unit Dimensions 18-30K

HOT WATER OUTLETS EFW

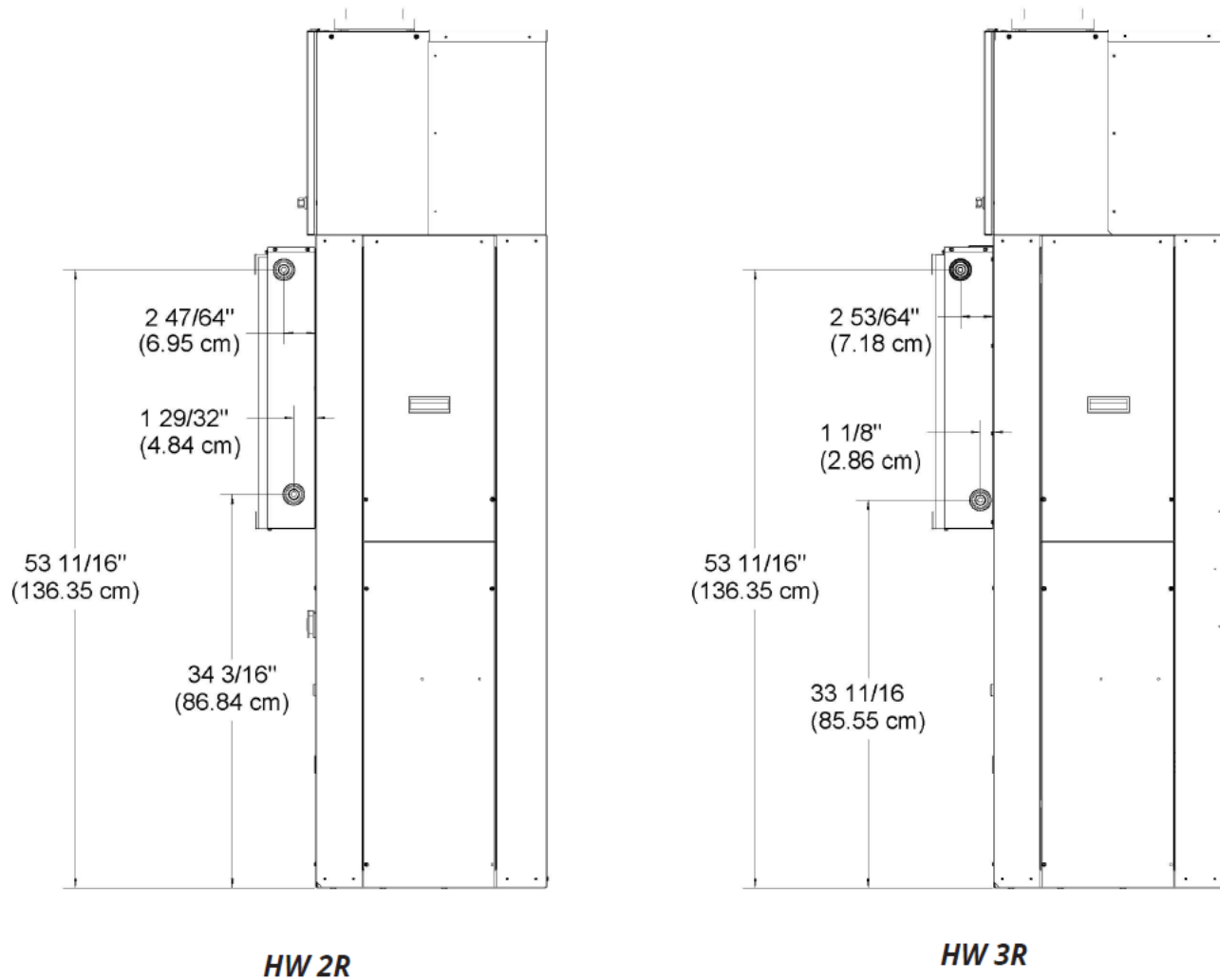

Figure 9 - EFW Hot Water Outlets

UNIT PHYSICAL DATA EFE

| PHYSICAL DATA | | | | | |
|---------------------------------------------|--------------------|-----------------|-----------------|-----------------|-----------------|
| 454B FRESH PAK AC | | EFE12 | EFE18 | EFE24 | EFE30 |
| Compressor (Quantity) | | Rotary (1) | | Scroll (1) | |
| Compressor FLA | | 4.6 | 7.6 | 9 | 12.8 |
| Factory Charge (R454B) | lb | 3.13 | 4.2 | 4.5 | 4.675 |
| | kg | 1.41 | 1.9 | 2.04 | 2.12 |
| Minimum Room Area | m ² | 4.3 | 5.7 | 6.2 | 6.4 |
| Minimum Room Area | Ft ² | 45.8 | 61.8 | 66.3 | 68.9 |
| Minimum Air Flow | CFM | 84 | 113 | 122 | 126 |
| | M ³ /hr | 143 | 193 | 207 | 215 |
| ID MOTOR | | | | | |
| Motor (Quantity) | | 1 | 1 | 1 | 1 |
| Fan Motor Type | | ECM | ECM | ECM | ECM |
| Motor HP | | 1/4 | 1/3 | 1/3 | 1/2 |
| Motor FLA | | 2.3 | 2.8 | 2.8 | 4.1 |
| OD MOTOR | | | | | |
| Motor (Quantity) | | 1 | 1 | 1 | 1 |
| Fan Motor Type | | ECM | ECM | ECM | ECM |
| Motor HP | | 1/4 | 1/3 | 1/3 | 1/3 |
| Motor FLA | | 2.3 | 2.8 | 2.8 | 2.8 |
| ID BLOWER | | | | | |
| Blowers (Quantity) | | 1 | 1 | 1 | 1 |
| Blower Wheel Size (D x W) in. [cm] | | 6 x 8 | 10 x 4 | 10 x 4 | 10 x 4 |
| | | [15.24 x 20.32] | [25.4 x 10.16] | [25.4 x 10.16] | [25.4 x 10.16] |
| EVAPORATOR COIL | | | | | |
| Dimensions (H x W) in. [cm] | | 24 x 16.25 | 24x22 | 24x22 | 24x22 |
| | | [61 x 41.275] | [61 x 55.88] | [61 x 55.88] | [61 x 55.88] |
| Face Area ft ² [m ²] | | 3.53 [2.70] | 3.53 [0.33] | 3.53 [0.33] | 3.53 [0.33] |
| Rows | | 3 | 4 | 4 | 4 |
| OD COIL | | | | | |
| Dimensions (H x W) in. [cm] | | 26 x 16.5 | 26 x 22.5 | 26 x 22.5 | 26 x 22.5 |
| | | [66 x 42] | [66 x 57] | [66 x 57] | [66 x 57] |
| Face Area ft ² [m ²] | | 3.0 [0.2772] | 4.1 [0.3762] | 4.1 [0.3762] | 4.1 [0.3762] |
| MISCELLANEOUS | | | | | |
| Throwaway Filter Dim. in. [cm] | | 24 x 24 | 24 x 24 | 24 x 24 | 24 x 24 |
| | | [60.96 x 60.96] | [60.96 x 60.96] | [60.96 x 60.96] | [60.96 x 60.96] |
| Throwaway Filter Quantity | | 1 | 1 | 1 | 1 |
| A2L MITIGATION | | NO | YES | YES | YES |
| Operating Weight lb. [oz] | | 270 [122.5] | 285 [129.3] | 300 [136] | 305 [138.3] |
| Packaged Weight lb. [oz] | | 290 [131.5] | 305 [138.3] | 320 [145.1] | 325 [147.4] |

Table 2 – Unit Physical Data

UNIT PHYSICAL DATA EFW

| PHYSICAL DATA | | | | | |
|---------------------------------------------|-----------------|-----------------|-----------------|-----------------|-----------------|
| 454B FRESH PAK AC | | EFW12 | EFW18 | EFW24 | EFW30 |
| Compressor (Quantity) | | Rotary (1) | | Scroll (1) | |
| Compressor FLA | | 4.6 | 7.6 | 9 | 12.8 |
| Factory Charge (R454B) | lb | 3.13 | 4.2 | 4.5 | 4.675 |
| | kg | 1.41 | 1.9 | 2.04 | 2.12 |
| Minimum Room Area | m ² | 4.3 | 5.7 | 6.2 | 6.4 |
| Minimum Room Area | Ft ² | 45.8 | 61.8 | 66.3 | 68.9 |
| Minimum Air Flow | CFM | 84 | 113 | 122 | 126 |
| | M3/hr | 143 | 193 | 207 | 215 |
| ID MOTOR | | | | | |
| Motor (Quantity) | | 1 | 1 | 1 | 1 |
| Fan Motor Type | | ECM | ECM | ECM | ECM |
| Motor HP | | 1/4 | 1/3 | 1/3 | 1/2 |
| Motor FLA | | 2.3 | 2.8 | 2.8 | 4.1 |
| OD MOTOR | | | | | |
| Motor (Quantity) | | 1 | 1 | 1 | 1 |
| Fan Motor Type | | ECM | ECM | ECM | ECM |
| Motor HP | | 1/4 | 1/3 | 1/3 | 1/3 |
| Motor FLA | | 2.3 | 2.8 | 2.8 | 2.8 |
| ID BLOWER | | | | | |
| Blowers (Quantity) | | 1 | 1 | 1 | 1 |
| Blower Wheel Size (D x W) in. [cm] | | 6 x 8 | 10 x 4 | 10 x 4 | 10 x 4 |
| | | [15.24 x 20.32] | [25.4 x 10.16] | [25.4 x 10.16] | [25.4 x 10.16] |
| EVAPORATOR COIL | | | | | |
| Dimensions (H x W) in. [cm] | | 24 x 16.25 | 24x22 | 24x22 | 24x22 |
| | | [61 x 41.275] | [61 x 55.88] | [61 x 55.88] | [61 x 55.88] |
| Face Area ft ² [m ²] | | 3.53 [2.70] | 3.53 [0.33] | 3.53 [0.33] | 3.53 [0.33] |
| Rows | | 3 | 4 | 4 | 4 |
| OD COIL | | | | | |
| Dimensions (H x W) in. [cm] | | 26 x 16.5 | 26 x 22.5 | 26 x 22.5 | 26 x 22.5 |
| | | [66 x 42] | [66 x 57] | [66 x 57] | [66 x 57] |
| Face Area ft ² [m ²] | | 3.0 [0.2772] | 4.1 [0.3762] | 4.1 [0.3762] | 4.1 [0.3762] |
| MISCELLANEOUS | | | | | |
| Throwaway Filter Dim. in. [cm] | | 24 x 24 | 24 x 24 | 24 x 24 | 24 x 24 |
| | | [60.96 x 60.96] | [60.96 x 60.96] | [60.96 x 60.96] | [60.96 x 60.96] |
| Throwaway Filter Quantity | | 1 | 1 | 1 | 1 |
| A2L MITIGATION | | NO | YES | YES | YES |
| Operating Weight lb. [oz] | | 270 [122.5] | 285 [129.3] | 300 [136] | 305 [138.3] |
| Packaged Weight lb. [oz] | | 290 [131.5] | 305 [138.3] | 320 [145.1] | 325 [147.4] |

Table 3 – Unit Physical Data

For installations in locations above 800 meters, the room size and mitigation airflow must be adjusted with a factor from this chart:

| Altitude Correction Factor | | | | | | | | | | | | | |
|----------------------------|------|------|------|------|------|------|------|------|------|------|------|------|-------|
| Altitude (m) | 800 | 1000 | 1200 | 1400 | 1600 | 1800 | 2000 | 2200 | 2400 | 2600 | 2800 | 3000 | 3200 |
| Altitude (ft) | 2625 | 3281 | 39.7 | 4693 | 5349 | 5906 | 6562 | 7218 | 7874 | 8530 | 9186 | 9843 | 10499 |
| Adj Factor (AF) | 1.02 | 1.05 | 1.07 | 1.1 | 1.12 | 1.15 | 1.18 | 1.21 | 1.25 | 1.28 | 1.32 | 1.36 | 1.4 |

ELECTRICAL DATA

| EFE ELECTRICAL DATA | | | | | | | | | | | |
|---------------------|--------------|------------|-----|---------------|-----|--------------|-----|-----------------------------|------|-----------------------------------|------|
| Model Number | Voltage | COMPRESSOR | | OUTDOOR MOTOR | | INDOOR MOTOR | | MIN. CIRCUIT AMPACITY (MCA) | | MAX. OVERCURRENT PROTECTION (MOP) | |
| | | RLA | LRA | FLA | HP | FLA | HP | (L1-L2) | | (L1-L2) | |
| | | | | | | | | 240V | 208V | 240V | 208V |
| 85FE12203E0D* | 208/230-1-60 | 4.6 | 25 | 2.3 | 1/4 | 2.3 | 1/4 | 19.0 | 17.0 | 20 | 20 |
| 85FE12205E0D* | 208/230-1-60 | 4.6 | 25 | 2.3 | 1/4 | 2.3 | 1/4 | 27.0 | 24.0 | 30 | 25 |
| 85FE18203E0D* | 208/230-1-60 | 7.6 | 36 | 2.8 | 1/3 | 2.8 | 1/3 | 20.0 | 18.0 | 20 | 20 |
| 85FE18205E0D* | 208/230-1-60 | 7.6 | 36 | 2.8 | 1/3 | 2.8 | 1/3 | 30.0 | 27.0 | 30 | 30 |
| 85FE18207E0D* | 208/230-1-60 | 7.6 | 36 | 2.8 | 1/3 | 2.8 | 1/3 | 40.0 | 36.0 | 40 | 40 |
| 85FE18210E0D* | 208/230-1-60 | 7.6 | 36 | 2.8 | 1/3 | 2.8 | 1/3 | 53.0 | 47.0 | 55 | 50 |
| 85FE24205E0D* | 208/230-1-60 | 9 | 63 | 2.8 | 1/3 | 2.8 | 1/3 | 30.0 | 27.0 | 30 | 30 |
| 85FE24207E0D* | 208/230-1-60 | 9 | 63 | 2.8 | 1/3 | 2.8 | 1/3 | 40.0 | 36.0 | 40 | 40 |
| 85FE24210E0D* | 208/230-1-60 | 9 | 63 | 2.8 | 1/3 | 2.8 | 1/3 | 53.0 | 47.0 | 55 | 50 |
| 85FE30205E0D* | 208/230-1-60 | 12.8 | 77 | 2.8 | 1/3 | 4.1 | 1/2 | 32.0 | 28.0 | 35 | 35 |
| 85FE30207E0D* | 208/230-1-60 | 12.8 | 77 | 2.8 | 1/3 | 4.1 | 1/2 | 42.0 | 37.0 | 45 | 40 |
| 85FE30210E0D* | 208/230-1-60 | 12.8 | 77 | 2.8 | 1/3 | 4.1 | 1/2 | 55.0 | 48.0 | 55 | 50 |

TABLE 4 ELECTRICAL DATA

For all models, units have single point power and can only operate either the compressor or electric heat, not both.

Refer to the wiring diagrams in the EFE IOM for additional details

Wire sizes should be determined in accordance with National Electrical Codes

Units are rated for 208/230V, but MOP,MCA values are calculated at 208/240V

ELECTRICAL DATA (continued)

| EFW ELECTRICAL DATA | | | | | | | | | | | |
|---------------------|--------------|------------|-----|---------------|-----|--------------|-----|-----------------------------|------|-----------------------------------|------|
| Model Number | Voltage | COMPRESSOR | | OUTDOOR MOTOR | | INDOOR MOTOR | | MIN. CIRCUIT AMPACITY (MCA) | | MAX. OVERCURRENT PROTECTION (MOP) | |
| | | RLA | LRA | FLA | HP | FLA | HP | (L1-L2) | | (L1-L2) | |
| | | | | | | | | 240V | 208V | 240V | 208V |
| 85FW1222RE0D* | 208/230-1-60 | 4.6 | 25 | 2.3 | 1/4 | 2.3 | 1/4 | 12.0 | 12.0 | 15 | 15 |
| 85FW1822RE0D* | 208/230-1-60 | 7.6 | 36 | 2.8 | 1/3 | 2.8 | 1/3 | 17.0 | 17.0 | 20 | 20 |
| 85FW1823RE0D* | 208/230-1-60 | 7.6 | 36 | 2.8 | 1/3 | 2.8 | 1/3 | 17.0 | 17.0 | 20 | 20 |
| 85FW2422RE0D* | 208/230-1-60 | 9 | 63 | 2.8 | 1/3 | 2.8 | 1/3 | 19.0 | 19.0 | 25 | 25 |
| 85FW2423RE0D* | 208/230-1-60 | 9 | 63 | 2.8 | 1/3 | 2.8 | 1/3 | 19.0 | 19.0 | 25 | 25 |
| 85FW3022RE0D* | 208/230-1-60 | 12.8 | 77 | 2.8 | 1/3 | 4.1 | 1/2 | 25.0 | 25.0 | 35 | 35 |
| 85FW3023RE0D* | 208/230-1-60 | 12.8 | 77 | 2.8 | 1/3 | 4.1 | 1/2 | 25.0 | 25.0 | 35 | 35 |

TABLE 5 – ELECTRICAL DATA

Refer to the wiring diagrams in the EFW IOM for additional details

Wire size should be determined in accordance with National Codes.

Units are rated for 208/230V, but MOP, MCA values are calculated at 208/240V

INSTALLATION

INSTALLATION PRECAUTIONS

CAUTION

Always wear all appropriate personal protection Equipment when installing and servicing units.

WARNING

Use multiple people to team lift when moving and installing these units.

Failure to properly lift units may result in personal injury or death.

CAUTION

Contact with metal edges and corners can result in personal injury. Protective gloves should be worn when handling. Exercise caution when installing and servicing unit.

Observe the following precautions for typical installation.

- Always use proper tools and equipment
- No wiring or any work should be attempted without first ensuring the unit is completely disconnected from the power source and locked out. Also, verify that a proper permanent and uninterrupted, ground connection exists prior to energizing power to the unit.
- Review unit nameplate and wiring diagram for proper voltage and control configurations. This information may vary from unit to unit.
- Units must be installed level to ensure proper drainage and operation.
- Be sure that the drain pan is free from foreign material prior to start up.

CAUTION

Components rotate at high speeds when the unit is in operation.

- Check filter media installation to ensure that it is installed correctly. Use the directional arrows or other information on the filter to determine the proper flow direction.
- Ensure air distribution system does not exceed the external static rating of the unit.

WARNING

When soldering and brazing, have a fire extinguisher available. When soldering and brazing close to valves or sensitive components, heat shields or wet rags are required to prevent damage to the valves or components.



NOTE



Damaged insulation must be repaired or replaced before the unit is placed back into operation. Insulation loses its insulating properties when wet, damaged, separated or torn.

CAUTION

When servicing this equipment, ensure that the reversing valve, expansion device, filter drier and other components are specifically designed for R-454B refrigerant.



INSTALLATION (continued)

WARNING



FIRE OR EXPLOSION HAZARD

Failure to following this warning could result in personal injury, death and/or property damage.



Do not attempt any sealed system repair without first recovering the entire refrigerant charge. R-454B refrigerant and oil mixture could ignite in the presence of a brazing torch flame. Completely recover the refrigerant charge using both the high and low sides of the system and purge the sealed system with nitrogen before brazing any component or tubing.

WARNING

Installation and service must be performed by a licensed professional installer (or equivalent), service agency. Attempting to install or repair this unit without such background may result in product damage, personal injury or death.

Work with extreme caution to minimize the risk of refrigerant ignition while installing and servicing a system containing a flammable refrigerant. Control the work environment as much as possible while potentially flammable vapors are present. Inform all persons on site about the risks of the nature of the work underway and the necessary safety precautions. Do not work in confined spaces. Test the work area for refrigerant in the air using an intrinsically safe A2L refrigerant leak detector before beginning work. Have a dry powder or CO2 fire extinguisher available. Use proper tools designed for A2L class refrigerants. While working near A2L refrigerants, use only non-sparking tools. Open flames and other ignition sources must not be present except during brazing. Brazing must only take place on evacuated and nitrogen purged refrigerant lines and components that are open to the atmosphere.

Consult local building codes and current editions of the National Electrical Code (NEC) NFPA 70. In Canada, refer to current editions of the Canadian electrical code CSA CEC22.1.

IMPORTANT

These units are for indoor installation **ONLY!**

INSTALLATION (continued)

UNIT LOCATION

This FRESH-PAK unit is certified for through-the-wall, indoor, up-flow vertical position installation only. This appliance is not design certified for installation in mobile homes, recreational vehicles, or outdoors. A factory approved wall sleeve must be used to install the FRESH-PAK unit.

The interior portion of the unit is surrounded by a closet with a rear access, refer to **FIGURE 10 - Condo with FRESH-PAK on Exterior Wall**. The vertical discharge allows for ducting to the top of the room for best air circulation and elimination of cold drafts on occupants. The exterior (grille side) of the unit must have no obstruction (trees, landscape material, etc.) within 30 in. [76.2 cm].

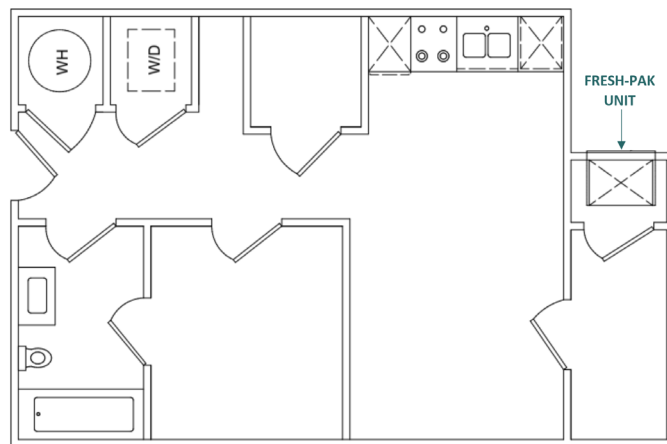

FIGURE 10 - Condo with FRESH-PAK on Exterior Wall

| | | |
|---------------------------------------------------------------------------------------------------------------|-------------|----------|
| i | NOTE | i |
| Do not locate two units adjacent to each other on an inside corner or where they may exhaust into each other. | | |

Provisions should be made to allow access to the indoor side of the unit for installation and inspection. The closet or access panel opening must be centered with the exterior wall opening and be at least 30 in. [76.2 cm] wide by 84 in. [213.36 cm] tall for all FRESH-PAK models.

12 in. [30.4 cm] (6 in. [15.24 cm] on sides without the ERV fresh air connection) of unobstructed clearance must be maintained around the FRESH-PAK chassis for adequate airflow to achieve optimum performance. These guidelines address minimum spacing requirements only. It is acceptable to go beyond these limits at any time. At least 29 in. [73.66 cm] of unobstructed space should be provided in front of the access door to permit removal of the unit, should repair and inspection be required.

| | | |
|--------------------------------------------------------------------------------------------------------------------------------------------------------|-------------|----------|
| i | NOTE | i |
| The FRESH-PAK units are designed for quiet operation. However, all air conditioning equipment will transfer a level of noise to the conditioned space. | | |
| This should be considered when planning the location of the equipment. | | |

| | | |
|-------------------------------------------------------------------------------------------------------------|-------------|----------|
| i | NOTE | i |
| The Architectural Louver must be installed prior to the installation of the FRESH-PAK unit into the sleeve. | | |

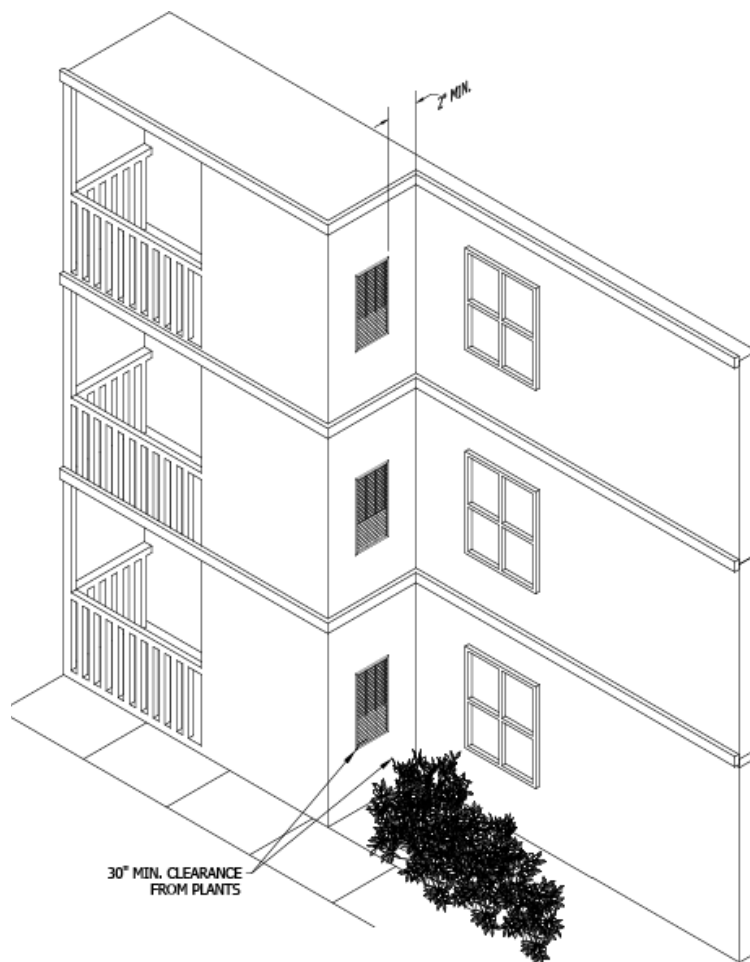

FIGURE 11 - Required Building Clearances

INSTALLATION (continued)

UNIT CLEARANCE REQUIREMENTS

Service clearance must be provided for future maintenance and service. A minimum of 29 in. [73.66 cm] open area must be left unobstructed in front of the access panels.

The louver side must be kept free from any obstructions to air flow. The unit must be installed at least 4 feet [1.22m] from electric meters, gas meters, regulators, and relief equipment.

| CLEARANCE REQUIREMENTS | | |
|-----------------------------------|--------|-----|
| MINIMUM CLEARANCE | INCHES | CM |
| Horizontal distance between units | 12 | 30 |
| Vertical distance between units | 60 | 152 |
| Distance above ground level | 6 | 15 |
| Distance above finished floor | 6 | 15 |
| Distance above a garage floor | 18 | 46 |

Table 6 - Clearance Requirements

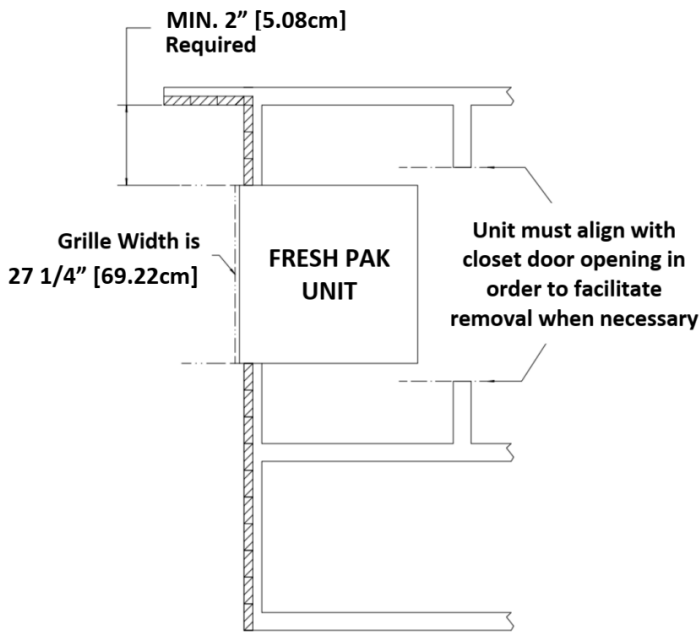

FIGURE 12 - Clearance Requirements

A unit installed in a garage must also be protected from damage by vehicles.

WALL SLEEVE INSTALLATION

Refer to installation instruction packed with the wall sleeve to assemble and mount into the wall. Before unit installation, verify that sleeve components are not damaged and that the drain line is unobstructed free of leaks.

Check all seals to ensure that they are in position and un-damaged. Ensure that the wall sleeve is sloped toward the exterior of the building. Securely fasten the Architectural louver to the front of the sleeve using the supplied hardware.

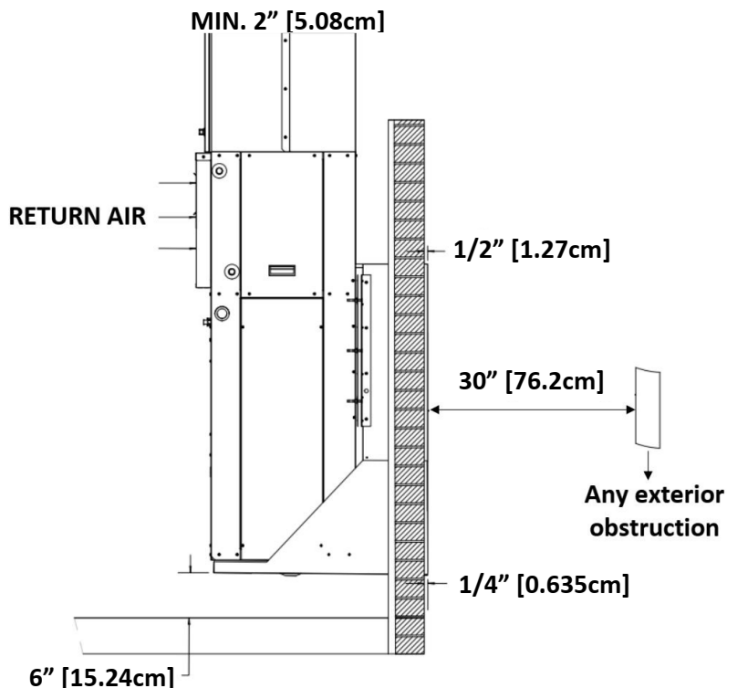

FIGURE 13 - Wall Sleeve Mounting

! IMPORTANT !

After sleeve installation, ensure that the gap in-between the wall and seal is insulated and is in contact with the sleeve sides.

INSTALLATION (continued)

WALL SLEEVE INSTALLATION CONTINUED REAR INSTALLATION & DIMENSIONS

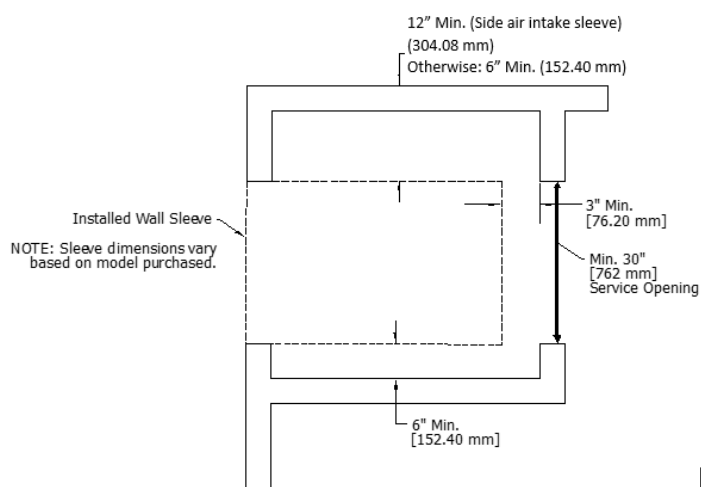

FIGURE 14 - Rear Installation

- Sleeve rough-in opening is 43-1/2 in. (H) [110.49 cm] x 26-3/4 in. (W) [67.94 cm].
- Bottom of opening should be approximately 6 in. [15.24 cm] about the floor.
- Minimum of 12 in. [30.4 cm] clearance required for side air intake sleeve insulation.
- Minimum of 6 in. [15.24 cm] clearance is required on the ERV fresh air (supply air) side.
- Minimum of 3 in. [7.62 cm] of clearance is required on all sides, except ERV fresh air (supply air) side, of the FRESH-PAK unit. See **FIGURE 14- Rear Installation**.



IMPORTANT



Apply a high grade non-hardening sealant approved for exterior at the following locations to prevent air and water from migrating inside:

1. Between edge of the sleeve and the structure
2. On the inside/outside walls.



CAUTION



Contact with metal edges and corners can result in injury. Wear protective gloves when handling. Exercise caution when installing and servicing unit.



CAUTION



Seal exposed joints to prevent water and outside air infiltration into the closet, which can cause improper unit operation and may cause damage the unit and other property.



NOTE



Locate the unit in an area that easily provides minimum clearance to all service access panels. Consider all additional clearances needed for water connections, electrical connections, duct connections and sufficient return airflow.



CAUTION



A masonry wall opening must be properly constructed with a lintel for wall support. Wall openings must be flashed and sealed. The unit must be level, front to back, side to side. Refer to CLEARANCE REQUIREMENTS section in this manual for more information.

INSTALLATION (continued)

PACKAGED UNIT INSTALLATION

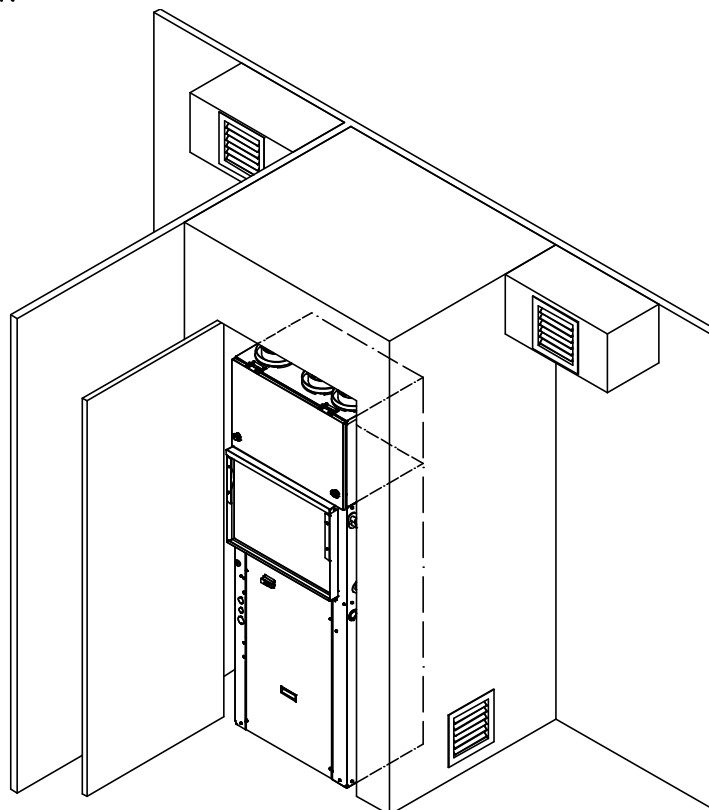

FIGURE 15 - FRESH-PAK Unit Installation



NOTE



DO NOT install unit in areas subject to freezing temperatures or where high humidity levels could cause cabinet condensation.

Units should be mounted on the sleeve with a pitch to the outside of the building.

Insulation is installed in indoor equipment to provide a barrier between outside air conditions surrounding the unit and the varying conditions inside the unit. If the insulating barrier is damaged, the surrounding ambient air will affect the inside surface temperature of the cabinet; this may lead to sheet metal corrosion and subsequently, component failure.

The installer must adhere strictly to all local and national code requirements pertaining to the installation of this equipment. All units are designed for indoor use only, and are agency listed for installation with clearances specified in **Table 6- Clearance Requirements**. This includes the cabinet, discharge plenum and connecting ducts.



NOTE



Check nameplate voltage, amperage and fuse size to ensure the proper power supply.

INSTALLATION (continued)

PACKAGED UNIT INSTALLATION

1. Remove the two shipping brackets holding the unit to the shipping pallet and remove unit from the shipping pallet.
2. Ensure that properly sized ductwork is in place to mate to the connections on the FRESH-PAK.
3. Before setting unit into closet, remove upper side access panel and inspect the evaporator blower to ensure that the wheel turns freely without rubbing on the housing.



NOTE



Remove the Styrofoam shipping block supporting the blower assembly.

4. Replace upper access doors prior to completing installation.
5. Remove the disconnect and the rear access door to get to the loose items described in the packing list. Check all electrical connections and check the condenser fan to see if it turns freely.
6. Remove the 4 ERV duct collars from inside the cabinet.
7. Attach unit mounting brackets (2) as shown in **FIGURE 16 - Mounting Brackets Installation**.

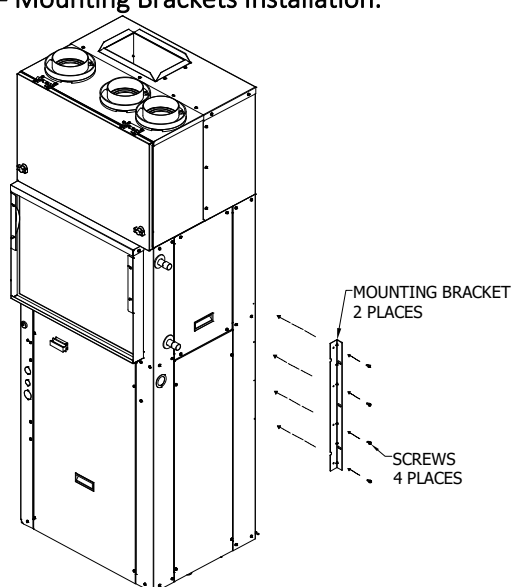

FIGURE 16 - Mounting Brackets Installation

8. Ensure that the wall sleeve is installed squarely and is secured before installing the unit.



IMPORTANT



After removing the construction debris guard, check the bottom of the sleeve pan to ensure that it is sloped toward the building exterior. Ensure that the bottom of the pan and drain are clear of obstruction and are operational.

9. After the seal is inspected, lift the unit onto the base of the sleeve and slide the unit forward to engage the seal. The unit uses locking brackets with weld studs. Align the unit to the bracket on the sleeve. Tighten down the unit until there is a tight seal with the sleeve. See **FIGURE 17 - Wall Sleeve Seal**.

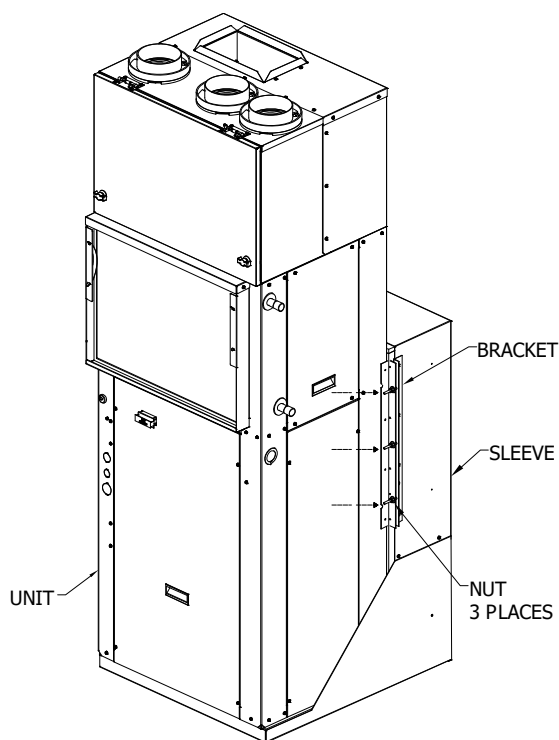

FIGURE 17 - Wall Sleeve Seal

10. Check that the unit is completely seated on all four sides against the wall sleeve seals.



CAUTION



If unit is not sealed properly, water and/or outside air will infiltrate the closet which may cause improper unit operation and can cause damage to the unit and/or property.

INSTALLATION (continued)

PIPING (HOT WATER COILS)

CAUTION

Prior to making piping connections, contractor must clean and flush water loop system. Failure to clean/flush system may result in nuisance tripping and premature component failure.

PIPING NOTES

1. Flush all field piping prior to connection to clear all debris.
2. Open all valves (mid-way for hand valves, manually open motorized valves) prior to soldering and brazing. Use proper heat shields to protect valve bodies.
3. When soldering or brazing to the unit, it is recommended to have a fire extinguisher readily available.
4. Use proper soldering and brazing techniques to protect valve bodies and unit components.
5. Heat can only be applied to the cup of the valve body for a minimal time before damage occurs (even with the use of wet rags).
6. Avoid rapid quenching of soldered joints to prevent weakening.
7. Make provisions for expansion and contraction of piping systems to provide movement with temperature changes. Failure to account for these factors will result in damage and failure of piping, fittings, and valves throughout the system.
8. **DO NOT** insulate the heads or motorized portion of control valves. Excessive heat build-up can cause damage and affect proper operation of the system.
9. Consider electrical routing when installing field piping.
10. Observe all regulations and codes governing installation of piping.

CAUTION

Hydronic systems are not designed to hold pressurized air and should only be tested with water.

Pressurizing system with air could damage equipment.

WARNING

Do not exceed 180 degree F (82 degrees C) water temperature..

When all connections are complete, pressure test the system, and repair any leaks or faulty joints.

PIPING INSTALLATION

1. All piping must be adequately sized to meet the design water flow requirements as specified for the specific installation. Piping must be installed in accordance with all applicable codes.
2. The piping connection on the equipment are not necessarily indicative of the proper supply and return line sizes. To minimize restrictions, piping design should be kept as simple as possible.

CAUTION

Do not bend or crimp the supply lines or hoses.

For all supply lines or hoses of 1.5 in. O.D. or larger, use properly sized fittings to prevent piping damage and potential restrictions in water flow.

3. Prior to connecting the FRESH-PAK all external piping must be purged of debris.
4. It is also recommended that all piping be insulated to prevent freezing when piping is run in all unconditioned spaces.

NOTE

Coil freeze protection is recommended for applications where the FRESH-PAK w/Hot Water is located in ambient air locations or within structures that may be unoccupied during freezing conditions.

Consult the Manufacturer for additional information.

| Hot Water Specifications | |
|---------------------------------------|------------|
| Maximum Design Pressure kPa (PSI) | 4137 (600) |
| Maximum Operating Temperature C° (°F) | 82.2 (180) |

TABLE 7

INSTALLATION (continued)



IMPORTANT



Do not restrict supply air by using a vertical duct with dimensions smaller than the supply air flanges.

Ne pas restreindre l'air soufflé en utilisant un conduit vertical dont les dimensions sont inférieures aux brides d'air soufflé.

DUCTWORK

Discharge ductwork is normally used with these units. When return air ductwork is required, the unit is supplied with 2 in. [5.08 cm] thick filter rack/duct collar for connection of return air ductwork. All ductwork must be installed in accordance with National Fire Protection Assoc. Codes 90A and 90B.

Supply and Return ducts must be sized properly as to not exceed static pressure capabilities of the unit. Ducts should be adequately insulated to prevent condensation and to minimize heat loss. A flexible connector is recommended for supply air connections on metal duct systems.

DISCHARGE DUCTING

All Ductwork must conform to industry standards of good practice as described in ASHRAE System Guide. The transition piece from the unit discharge to the duct distribution system must not have an angle greater than 30° or severe loss of air performance can result.

Do not connect the full duct size to the unit discharge collar without using a transition piece down to the size of the unit discharge collar. With metal material, the sides of the elbow and entire branch duct should be internally lined with acoustic insulation for sound attenuation.

The ductwork should be configured such that there is no line of sight between the unit discharge and the distribution diffusers.



NOTE



Follow the filter rack kit instructions & recommendations for installation.

RETURN AIR DUCTING

Return air duct can be brought in through a wall grille and then to the unit. The return duct system will normally consist of flexible connector at the unit and a trunk duct to the return air grille. With metal duct material, the return air duct should be internally lined with acoustic insulation for sound attenuation.

A 2 in. [5.08 cm] air duct collar flange is included on the filter rack for ducted return air application. A flexible duct collar can then be attached between a duct transition and the return air ductwork. The return air duct transition must be the same size as the return air coil face area. See **FIGURE 18 - Ductwork**. Be sure to allow for proper clearance to allow for filter change outs.

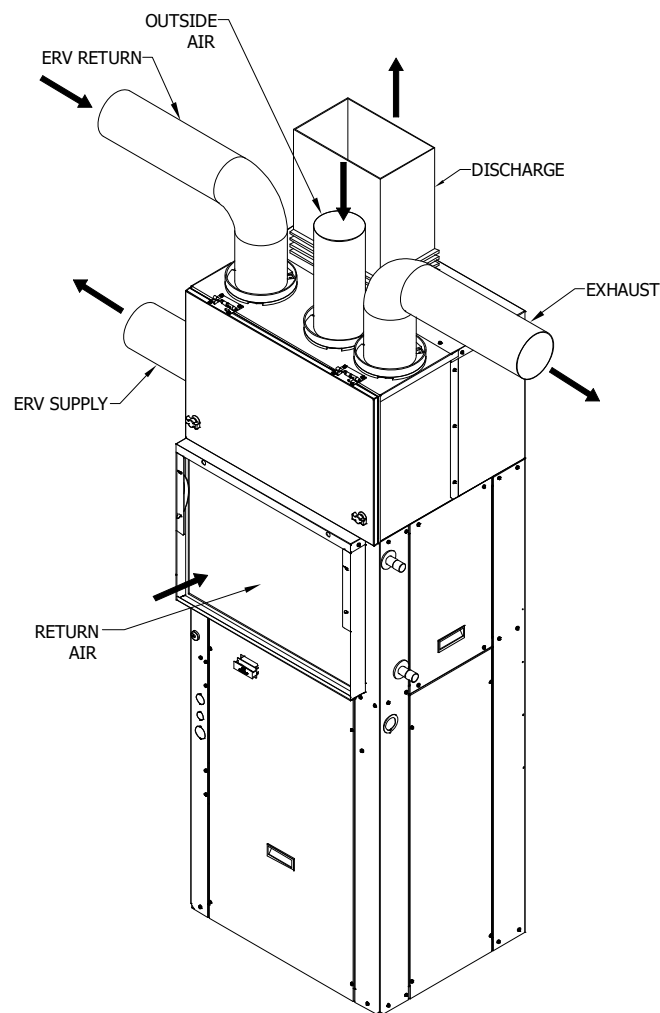
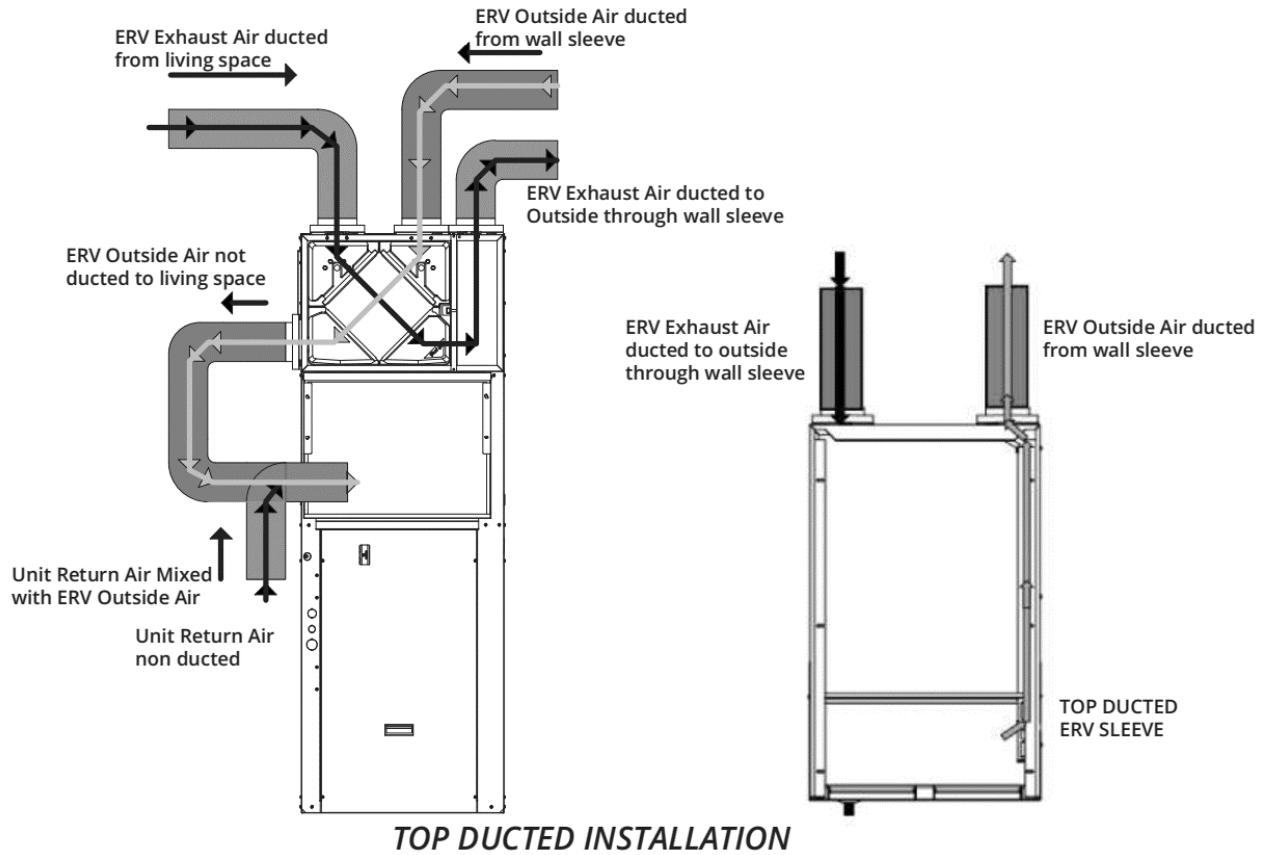

FIGURE 18 - Ductwork

ERV AIR DUCTING

The ERV module requires fresh/exhaust air ducted from/to outside the building and return air ducted from the occupied space. The ERV supply can be discharged into the open return of the closet. If the unit return air is ducted, the ERV supply air must be ducted into the return as well for proper ventilation and filtration. Examples on ducting the ERV air flow, refer to **FIGURE 19 – ERV AIRFLOW PATHS**

INSTALLATION (continued)



! IMPORTANT !
 All ductwork must be installed in accordance with National Fire Protection Assoc. Codes 90A and 90B

i NOTE i
 The Fresh Pak wall sleeve with integrated ventilation air intake and exhaust ports ensures a minimum of 36" of separation between the ventilation air intake and exhaust discharge.

FIGURE 19-ERV AIRFLOW PATHS

INSTALLATION (continued)

CONDENSATE DRAIN

The FRESH-PAK is designed so that the wall sleeve is the principle drain pan. Drain tubing is factory installed which drains evaporator condensate through the bottom of the unit which then is allowed to drain into the wall sleeve pan.

Condensate drain lines must be installed with adequate slope to ensure positive drainage.

Prior to unit installation ensure that the drain is unobstructed and leak free.

! **CAUTION** !

On units with plastic drain pans, the drain connection must be made hand tight only.

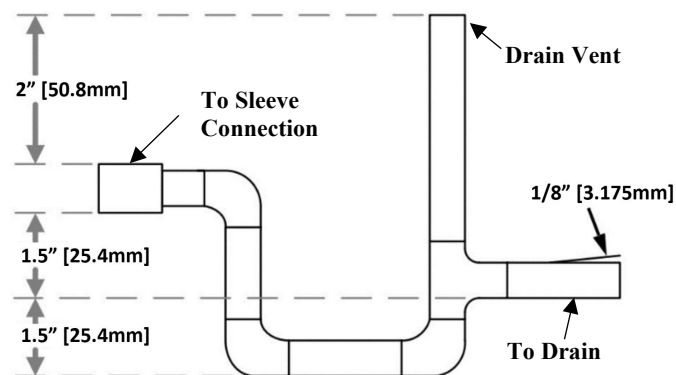

FIGURE 20 - Condensate Drain

i **NOTE** i

While preparing unit for installation, ensure that the drain tubing from the evaporator is securely attached to the copper nipple in the pan under the compressor. The wall sleeve has a 3/4in. NPT nipple located in the bottom for connection to a drain (FIGURE 20 - Condensate Drain). A trap may be required in the condensate drain line to prevent sewer gas from escaping into the room.

AIR FILTER

All indoor return air must be filtered. The preferred methods are listed below.

1. Use the factory supplied filter kit which attaches to the inlet of the evaporator.
2. Use the filter kit supplied with the access panel which accepts an 18 in. [45.72 cm] x 20 in. [50.8 cm] x 1 in. [2.54 cm] (or 2 in. [5.08 cm]) throwaway type of filter.
3. If a field installed filter rack is installed in the return air system, the filter must not be smaller than the surface area of the evaporator coil.

! **CAUTION** !

DO NOT operate this equipment without an air filter.

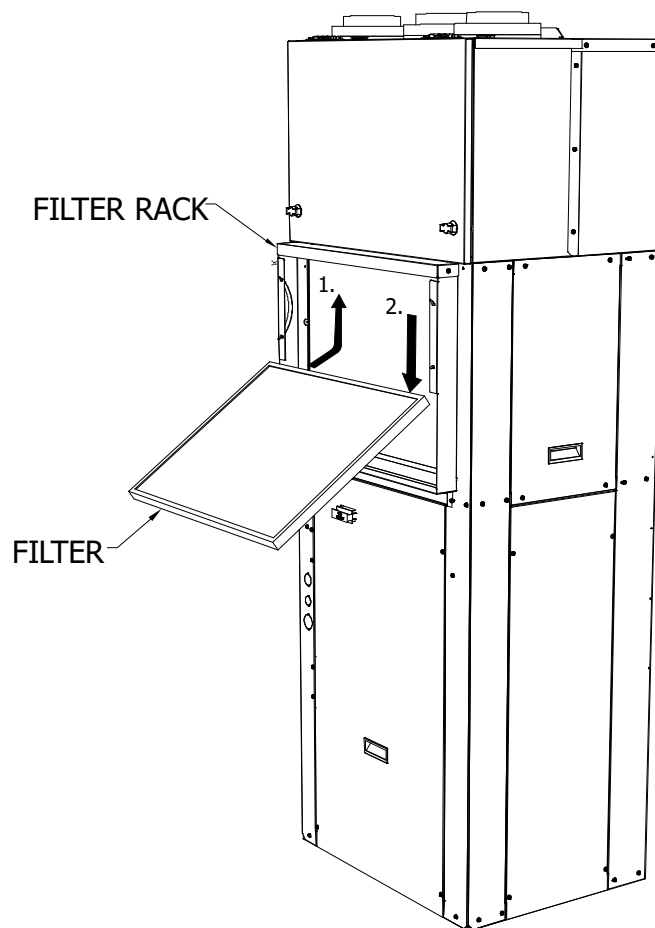

FIGURE 21 - Air Filter

| Operating Range °F [°C] | | |
|-------------------------|-----------|------------|
| Condition | Cooling | |
| | Min | Max |
| Outdoor DB | 60 [15.6] | 115 [46.1] |
| Indoor DB | 60 [15.6] | 90 [32.2] |

Table 8 – Unit Operating Range

ELECTRICAL

HIGH VOLTAGE

! IMPORTANT !

Electrical work associated with the installation of this appliance must comply with the National Electrical Code (NEC). Other local or regional electrical and building code requirements may apply.

In Canada electrical work associated with the installation of this appliance must comply with CE CSA C22

! WARNING !

The unit cabinet must have an uninterrupted / unbroken ground to minimize personal injury if an electrical fault should occur. Failure to do so can cause electrical shock resulting in severe personal injury or death.

Ensure field wiring complies with local and national fire, safety, and electrical codes. Ensure voltage supply is within limits shown on unit rating plate. Contact the local power company for correction of improper voltage. Refer to the unit rating plate for recommended circuit protection device.

! WARNING !

ELECTRIC SHOCK HAZARD

Disconnect all power supplies before servicing. Lock out/tag out to prevent accidental electrical shock.

NOTE: There may be multiple power sources supplying the unit.

! WARNING !

USE COPPER CONDUCTORS ONLY!

Install all parts and panels before operation of unit. Failure to follow these warnings can result in personal injury or death.

Units are provided with a class 2 transformer for 24VAC control circuits. Should any add-on accessory or component also have a class 2 transformer furnished, care must be taken to prevent interconnecting outputs of the two transformers by using a thermostat with isolating contacts.

! WARNING !

Electrically ground the unit. Connect ground wire to ground lug. Failure to do so can result in injury or death.

! WARNING !

Do not bypass or eliminate safety devices.

! CAUTION !

Any device that has been furnished by the factory for field installation must be wired in strict accordance with the associated wiring diagram. Failure to properly wire the unit may damage components and void warranties.

! WARNING !

Connect ground wire to ground terminal marked "GND". Failure to properly ground the unit may result in personal injury or death.

208 VOLT OPERATION

All 208-240 Volt units are factory wired for 240 Volt operation. For 208 Volt operation; on the primary side of the transformer (line voltage), move the black wire from the 230 volt tap to the 208 volt tap. See note on unit wiring diagram for instructions.

LOW VOLTAGE

THERMOSTAT

A minimum 24 VAC Ventilation thermostat is required to operate the FRESH-PAK unit. Thermostat is required with a fan signal (G) in all operating Modes). Thermostat connections and functions are as follows:

| THERMOSTAT CONNECTIONS KEY | | |
|----------------------------|--------|----------------------------------|
| LETTER | COLOR | DESCRIPTION |
| C | BROWN | Transformer 24VAC Common |
| R | RED | Transformer 24VAC Hot |
| G | GREEN | Evaporator Blower |
| U | YELLOW | ERV Comfort Common |
| Y | BLUE | Compressor Contactor |
| Y2 | PINK | Compressor 2 nd stage |
| W2 | BLACK | Auxiliary Heating |

Table 9 - Thermostat Connections Key

THERMOSTAT INSTALLATION

Use 18 AWG wire with color-coded insulation (35°C minimum) up to 100 ft. in length (31 m). Use 16 AWG wire if more than 100 ft. of wire is required

The Thermostat should be located on an interior wall in a larger room, away from supply duct draft. Position the thermostat back plate against the wall so that it appears level and so the thermostat wires protrude through the middle of the back plate mounting holes and drill holes with a 3/16 in. bit. Install supplied anchors and secure plate to the wall. Thermostat wire must be 18 AWC wire.

CONTROLS (continued)

ECO SERIES CONTROL MODULE

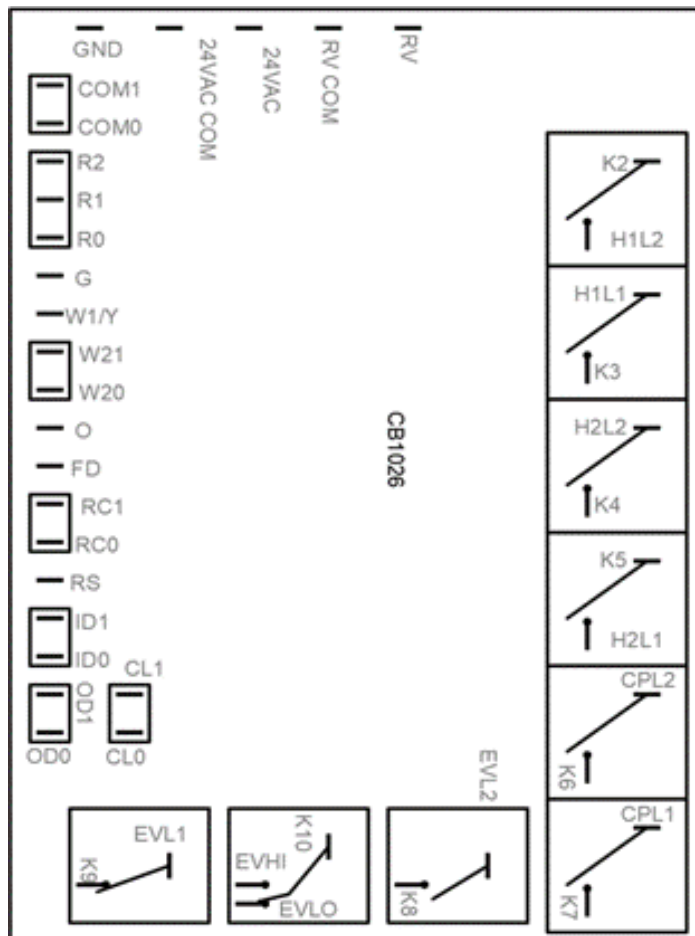

FIGURE 23 - ECO Series Control Module

POWER-UP

When power is first applied to the control, all timers are reset. The control will execute a random start delay before allowing normal operation of outputs, and a compressor anti short cycle delay (6 minute) before allowing the compressor output to be energized. While the control is operating, all of the inputs are continuously monitored for a change in the desired operating status.

RANDOM START DELAY

There will be a control random start delay which will vary from 10 to 60 seconds, which will be executed before energizing outputs when the control is powered up. All control outputs remain off during the random start delay.

ANTI-SHORT CYCLE DELAY

After the compressor output has been energized the control will execute a 6-minute anti short cycle delay from the time the compressor is de-energized, before allowing the compressor output to be energized again. A 6-minute anti short cycle delay will be present at control power up, before allowing the compressor output to be energized.

POWER INTERRUPTIONS

If the power to the control is interrupted for less than 100 milliseconds, the control shall resume operation at the same point in the timing cycle if the compressor output is not energized. Relays may temporarily drop out during the power interruption. Power interruptions greater than 100 milliseconds are to reset the control as a power- sequence. If the power to the control is interrupted for more than 40 milliseconds with the compressor output energized, the compressor output will be de-energized, and the control will execute a short cycle delay before allowing the compressor to operate.

CONTROLS (continued)

COOLING OPERATION

STEADY STATE COOLING

When the “W1/Y” input is present, and the compressor is not being held off by the anti-short cycle timer, the control will operate in steady state cooling. In steady state cooling, the compressor and condenser fan are energized. After a 7 second delay the evaporator fan is energized. For units with 2-stage compressors, if the only the “W1/Y1” input is present, the control will operate in low speed cooling, energizing the low speed evaporator fan. If the “Y2” input is applied with a “W1,Y1” input, the unit will operate in full speed cooling and energize the high speed evaporator fan.

If the W2 input is applied to the control, the auxiliary heat output will be energized immediately. The compressor and condenser outputs will be shut off and the evaporator fan will switch to low speed. When the “W2” input is removed, the auxiliary output will be turned off immediately, and the control will return to steady state cooling mode, assuming the “W1/Y” input is still present.

When the “W1/Y” input is removed, the compressor and condenser fan will be turned off immediately. For 2 stage units, if a “Y2” input is applied without a “W1/Y1”, the compressor will not energize, however the high speed evaporator fan will energize. The high-speed evaporator fan will be turned off following a 45 second blower off delay.

LOW AMBIENT SHUTDOWN

When the control is operating in steady state cooling, and the “INDOOR” input is applied (temperature 30°F [-1°C] and below), the control will immediately de-energize the compressor and condenser fan. The high-speed evaporator will be turned off following a 45 second blower off delay. The compressor will go into an anti-short cycle delay for 6 minutes.

LOW AMBIENT COOLING LOCKOUT

When the control is operating in steady state cooling and the “COOLING LOCKOUT” input is applied (Outside Temperature of 40°F [4.4°C] or less) the control will continue to operate for 10 minutes. After 10 minutes, if the “COOLING LOCKOUT” is still active the cooling operation will be locked out for 30 minutes and run high speed evaporator during the lockout. After 30 minutes the control will be returned to normal operation.

AUXILIARY HEATING OPERATION

THERMOSTAT CALL FOR AUXILIARY HEAT

If the “W2” thermostat input is present without a “W1/Y” input, the control will operate in the auxiliary heat mode. The low-speed evaporator fan and the auxiliary heat output will be energized immediately when the “W2” input is received. When the “W2” input is removed, all of the outputs will be turned off immediately.

If the “W2” thermostat input is present with a “W1/Y” input, the control will switch the system to auxiliary heat mode and will de-energize the compressor and condenser fan immediately.

LOW ROOM AMBIENT AUXILIARY HEAT

If the “RS” low room temperature input becomes active (switch closes), the control will operate in the auxiliary heat mode, regardless of any other control inputs. The low-speed evaporator fan and the first stage auxiliary heat outputs will be energized immediately when the “RS” input is received. After a 15 second staging delay, the second stage auxiliary heat output will be energized. When the “RS” input is removed, all of the outputs will be turned off immediately.

DEFROST LOCKOUT

When the control has inputs for first or second stage heating, and the “OUTDOOR DEFROST” input is removed (switch opens), the compressor and condenser fan outputs are de-energized, and the evaporator fan switches to low speed. If the auxiliary heat outputs are not already active, the first stage of auxiliary heat is energized immediately, and the second stage is energized after 15 seconds.

Any time the “OUTDOOR DEFROST” input is removed (switch opens), a six (6) hour timer is activated and the compressor and condenser fan will not operate until the time has expired. During the time the compressor and condenser fan are locked out, the auxiliary heat will be energized any time there is a “Y” or a “W2” input.

CONTROLS (continued)

CONTINUOUS FAN OPERATION

If no other thermostat inputs are present, the low-speed evaporator fan output will be energized when the “G” thermostat input is active. If either or both of the “Y” or “W2” inputs are present, the operation of the evaporator fan will be based upon those inputs, and the “G” thermostat input will be ignored. compressor and condenser fan and will only allow auxiliary heat operation. In the case of the “W2” input interrupting the compressor operation, the auxiliary heat will continue to operate until the thermostat is no longer calling for heat.

THERMOSTAT INPUT OPERATION (Y, W2)

If both “Y” and “W2” thermostat inputs are active, the control will lock out or interrupt the operation of the compressor and condenser fan and will only allow auxiliary heat operation. In the case of “W2” input interrupting the compressor operation, the auxiliary heat will continue to operate until the thermostat is no longer calling for heat.

FIELD SPEEDUP MODE

The field speedup mode is entered by applying R (24VAC) to Y (active) without “B” being active (Cooling Mode), and closing the cooling lockout sensor switch (24VAC applied to the terminal). The field speedup mode is automatically canceled after 5 minutes. While in the field speedup mode, control timings will be reduced as follows:

| | |
|------------------------------|-----------|
| Random Start Delay | 0 Seconds |
| Short Cycle Delay | 5 seconds |
| Cooling Blower off Delay | 0 Seconds |
| Auxiliary Heat Staging Delay | 1 Second |

FRONT DESK SHUTDOWN OPERATION

If the front desk shutdown input “FD” is removed (switch opens), operation based upon the “Y”, “W2” and “G” thermostat input will be prohibited. Auxiliary heat operation based upon the low room ambient temperature input “RS” is the only heating or cooling operation that will be allowed. When the “FD” input is re-applied (switch closes), the control will return to normal operation based upon the thermostat inputs.



NOTE



From the factory this will not shutdown the ERV. This will only shutdown the Heating/Cooling modes.

A2L SENSING AND MITIGATION

Units charged with over 4lbs (1.81kg) of R454B refrigerant are shipped with a factory installed refrigerant leak detector attached to the evaporator coil. In the event that a refrigerant leak is detected, the controls will disable the compressor operation, and energize the evaporator fan to disperse the leaked refrigerant. The unit will operate in this mitigation state until the sensor no longer detects a refrigerant leak, for a minimum time of 5 minutes. Once the mitigation period has ended, the unit will return to its normal operation based on the current thermostat inputs. An LED status light is provided with the sensor for diagnostic purposes, the description of the LED status light signals can be found in the troubleshooting section.

CONTROLS (continued)

ERV CONTROL MODULE

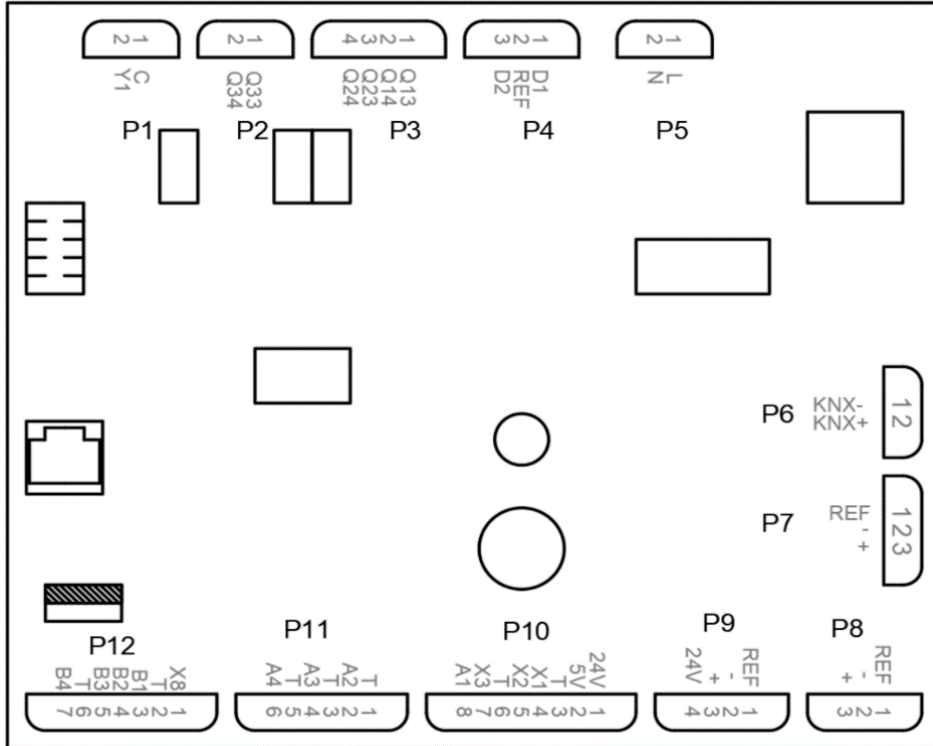

FIGURE 24 - ERV Control Module

| ERV CONTROL MODULE KEY | | |
|------------------------|---------------------------------------------------------------------------------------------------|--------|
| INTERFACE | TYPE | NOTE |
| B1, B2, B3, B4 | Analog Input 1: Resistor NTC10k | AI |
| X1, X2 | Analog Input 1: Measuring 0---10V 2) Tacho pulse (max. 300Hz) | AI |
| X3 | Analog / Digital (Binary) Input 1: Measuring 0---10V 2: Potential free contact (NO or NC) | AI, BI |
| A1, A2, A3, A4 | Analog Output 1: Signal 0---10V | AO |
| X8 | Analog / Digital (Binary) Input 1: Resistor NTC10K 2: Potential free contact (NO or NC) | AI, BI |
| D1, D2 | Digital (Binary) input 1: Potential free contact (NO or NC) | BI |
| Q1, Q2, Q3 | Relay (Binary) Output 1: Potential free contact (NO) | BO |
| Y1 | Digital (Binary) / Analog Output triac VAC 1: Signal On/Off 2: Signal PWN (constant period) | BO, AO |

Table 10 - ERV Control MODULE KEY



NOTE



TO MAKE ERV CONTROL CHANGES:
CONNECT EITHER OPTIONAL WIFI KIT OR BACNET COMMUNICATION TO THE ERV.

CONTROLS (continued)

ERV DEFAULT CONFIGURATION

The controller's I/O are preconfigured for the following applications:

- Supply exhaust fan speed control
- Outside air damper control (on off)
- Contact input for rapid ventilation (Fan boost) and occupied operating mode
- Common alarm output

| DEFAULT ERV CONFIGURATION | | | | |
|---------------------------------------------------------------|--------------------------------------|---------------|-------------|------|
| PIN | DESCRIPTION | BACNET OBJECT | SIGNAL TYPE | NOTE |
| B1 | Outside air temperature | TOa | NTC10k | |
| B2 | Supply air temperature | TSu | NTC10k | |
| B3 | Exhaust air temperature | TEh | NTC10k | |
| B4 | Extract air temperature | TEx | NTC10k | |
| D1 | Rapid ventilation input | RpdVntIn | Contact | NO |
| D2 | Input room operating mode Comfort | OpModRin | Contact | NO |
| X1 | Supply air fan speed feedback pulse | FanSuSpdFb | 0---30 Hz | |
| X2 | Exhaust air fan speed feedback pulse | FanEhSpdFb | 0---30 Hz | |
| X3* | None | - | - | |
| X8* | None | - | - | |
| Q1* | None | - | - | |
| Q2 | None | - | - | |
| Q3 | Outside air damper command | DmpOaCmd | Relay | |
| A1 | Supply air fan speed | FanSuSpd | 0---10V | |
| A2 | Exhaust air fan speed | FanEhSpd | 0---10V | |
| A3 | Mixing air damper position | MADmpPos | 0---10V | |
| A4 | Outside air damper position | OADmpPos | 0---10V | |
| Y1 | None | - | - | |
| *Not active from the factory will require field configuration | | | | |

Table 11 - Default ERV Configuration

| ERV Modes of Operation | | | | |
|----------------------------------|---------------------|---------------|------------------|---------------------------------------------------------------|
| OPERATING MODE | CATEGORY | OPERATING VIA | DURATION | ACTIVATION SIGNAL |
| Protection | Off mode | APP, DI | Permanent | |
| Unoccupied | Normal or away mode | APP, POS8, DI | Permanent or TSP | |
| Economy | Normal mode | APP, POS8, DI | Permanent or TSP | |
| Comfort | Normal or Home mode | APP, POS8, DI | Permanent or TSP | |
| Fan boost (Rapid ventilation) | Temporary mode | APP, POS8, DI | Temporary | Continuous or pulse signal (Duration can be parameterized) |

Table 12 - ERV Modes of Operation

CONTROLS (continued)

ERV DEFAULT CONFIGURATION

OPERATING MODE CATEGORIES

The following selectable operating modes belong to operating mode categories.

NORMAL MODES

The normal modes Unoccupied, Economy, and Comfort are the main operating modes that can be applied for a constant and, if desired, infinite time. For each one, certain settings are defined, which sensibly apply to the corresponding state of the system.

- **Unoccupied** - the building is unoccupied and the system is operated with the most essential settings needed.
- **Economy** - The building is occupied, but the system is operated with economical, energy efficient settings
- **Comfort** - The building is occupied and the system is operated according to the needs of the user.

TEMPORARY MODES

The modes Fan Boost, is a temporary mode that can only be activated for a certain, settable time. The temporary mode is activated either via POS8.44X0 or configured digital input as an impulse button or, when pressed longer, as an "egg timer".

Once activated, they override all normal operating mode and for the set time, the dedicated settings for the temporary mode apply, which mostly concerns the fan speed.

SIGNAL FOR FAN BOOST

If the duration of the signal is <5 seconds:

- The Signal is interpreted as an impulse: The temporary mode is started and only stopped when the timer has expired.

If the duration of the signal is >5 seconds:

- The signal is interpreted as an "egg timer": Temporary modes is started when the signal is activated and stopped when the signal is inactive.

OFF MODE

The operating mode Protection switches the system into a form of "Off" mode in which the fans no longer run. However, the system is not switched off completely, individual pumps can continue to operate and the frost protection strategy continues to run for as long as has been set. The Protection mode can only be set in the configuration and cannot be set by the end user themselves (neither via app nor POS8.44x0).

OPERATING MODE SETTING

The settings for the operating modes define the specific settings for the supply and exhaust fans for all operating modes and for the speed and flow control strategies. These settings are configured by the installer. The end user has no option to change the values for the operating modes.

For Comfort, Economy, and Unoccupied modes, dedicated settings for temperature can be defined. The temporary operating modes Fan Boost, In-room-sensor, have no dedicated temperature settings. For these modes, the settings of Comfort mode apply.

FAN SPEED CONTROL

Supply fan and exhaust fan set points have defined setting for each operating mode level. Individual percentage value is used between 0---100%. These settings only define the fan speed used in various operating modes and they have no effect on other functions like de-icing.

During active temperature control, values set here are used as maximum speed (80%). Depending on deviations to set point, temperature control can freely increase/decrease the speed of both fans simultaneously with symmetrical control signal which then keeps the set supply/exhaust ratio in every situation.

FAN BOOST

The Fan Boost mode can be activated as a temporary mode to temporarily increase ventilation, e.g., after a bath or in a sauna. In this case, Fan boost is activated directly and kept active until the set time has elapsed. The Fan boost mode uses the fan speeds defined for the Comfort operating mode.

PASSIVE HEAT EXCHANGER, UNCONTROLLED (PLTHEXG22Y)

The purpose of energy recovery is to absorb heat/cold from the exhaust air and transfer it back to the supply air side. The control of the energy recovery is not possible, the ERC always works with maximum capacity. With this solution, the outside air cannot be used for heating or cooling even if the outside air is closer to the set point than the exhaust air (e.g., in rooms with a high internal load or when heating up after cold nights.)

CONTROLS (continued)

C DE-ICING (PASSIVE, UNCONTROLLED)

Passive Energy Recovery units are basically just heat exchangers. They receive warm and humid air on one side and cold on the other which will eventually cumulate ice on the surfaces when the conditions are suitable for that. Passive element usually starts to cumulate ice close to 32° F [0° C].

ERV DEFAULT CONFIGURATION

DETECTING ICE ON THE HEAT EXCHANGER OR IN THE DUCT WORK

Detecting ice on the heat exchanger or in the ductwork is possible.

- With exhaust air temperature sensor TE_h. This is not a real indication, but an expectation that ice is expected to build up.
 - Deicing with TE_h sensor starts with TE_h is below the limit.
 - The end of the de-icing phase cannot be detected and is estimated via timer.
- With outside air sensor TO_a. This is used when no exhaust air sensors are available. It is also only an expectation that ice has built up.
 - De-icing with TO_a sensor starts when the TO_a is below the limit.
 - The end of the de-icing phase cannot be detected as is estimated via timer.

DE-ICING THE HEAT EXCHANGER

De-icing is possible by:

- Reducing the supply fan speed, so that the load of cold air incoming is reduced, increasing the exhaust air temperature.
- Preheating the outside air, increasing the exhaust air temperature.

DE-ICING MODES

The de-icing mode can be configured as:

- No De-icing
- Reduce fan speed
- Increase preheating
- Reduce fan speed and increase preheating

Deicing with fan speed is running in parallel or with 2-stage, see below.

TIME BASED DE-ICING STARTED BY TE_h OR TO_a

The sensor is not suitable for detecting the end of the de-icing phase. Therefore, a fixed de-icing time is used. After de-icing is finished, an off time is started until the next de-icing phase can be started again. The duration of the off time depends on the measured temperature at

the start of the de-icing phase. De-icing time, maximum off time with assigned temperature and minimum off time with assigned temperature can be configured.

DE-ICING WITH REDUCED FAN SPEED STARTED BY TE_h OR TO_a

The temperatures have 2 adjustable limits. The limit SpTDeicFan (stage 2) starts de-icing with the fan speed. During deicing, fan speed for supply fan and exhaust fan are reduced to configurable values. For faster de-icing, it is possible to set supply fan speed set point even to 0%. In this case electric heaters in the supply air are blocked.

ERC SUPERVISION (PASSIVE, UNCONTROLLED)

A mechanical failure on the ERV (heat exchanger dirty etc.) can be detected via the efficiency of the heat exchanger. Therefore, the temperature difference between extract air / room air and exhaust air is used. When the difference drops below set value and stays below during set delay time, alarm is generated. Detection function is active only when temperature difference between outside air and extract air is more than set limit. When extract air temperature and exhaust air temperature are not available, the supervision of the ERV is not possible.

PRIORITY LIST

Different functions require priorities over the other functions so that logical/critical operation can be guaranteed.

- Safety functions (field configured)
 - Off by smoke detector, emergency, supply air temperature or extract air temperature
 - Off by fire damper closed
 - Purge or smoke extract by smoke detector
- Protection functions
 - A-Alarms for plant protection
 - ERC de-icing function
- Switch or push-button operations
 - Rapid ventilation mode (Configured B1, POS8)
 - Comfort mode (Conf. B1), Fireplace (Conf. B1), Off mode (Conf. B1), Eco mode (Conf. B1)
 - Maintenance function
- User operation
 - Present / Away button
 - Manual operation
- Automatic Function
 - Scheduler operation mode

CONTROLS (continued)

ERV DEFAULT CONFIGURATION

OUTSIDE AIR DAMPERS (DMPSHOFFOA11Y)

When ventilation is active the outside air dampers are always open. Damper(s) are controlled open/close from one binary output. Delay time for outside air damper opening can be defined to secure that damper is fully open before fans are started.

STARTUP / SHUT-DOWN SEQUENCE

For safe and optimum operation of the ventilation unit, special switch-on and switch-off sequences are used to switch the ventilation off and on again. The ventilation unit is normally not “switched off”, but can be switched off for maintenance work or in emergency situations. This can be done by opening the ERV maintenance panel releasing the door switch signal or by powering down whole FRESH-PAK system. The start –up sequence is used every time except in emergency situations. The start-up sequence applies also for fire damper test function which is performed automatically.

STARTUP SEQUENCES

1. Start is initiated.
2. Only after power return. Delay time step 2 (to secure startup time for valves, fire dampers and ERV)
3. If available open the outside air dampers. Delay time step 3 (to secure dampers fully open). If damper output cannot be switched, an A-Alarm is activated, the startup process is stopped.
4. ERV ramps up to maximum speed. Heat exchangers bypass closes. Exhaust fan starts and ramps up to comfort mode speed. If exhaust fan speed is monitored, and the feedback signals is not received within the delay time, an A-Alarm is activated, the starting process is stopped. Delay time step 5 (to secure “heating up” of heat exchanger)
5. Supply fan starts and ramps up to “unoccupied” mode speed Delay time step 6. If supply fan speed is monitored, and the feedback signal is not received within the delay time, and A-Alarm is activated, the starting process is stopped.
6. Both fans ramp to required operating mode speed. Delay time step 6 preparing for normal operation.
7. Normal operating mode is started.

SHUTDOWN SEQUENCES

Executed after normal operation or if startup is interrupted after step 4 is finished. Shutdown sequence is not used in emergency situations.

1. Shutdown is initiated.
2. Both fans ramp down to stop.
3. Close the outside air dampers, same time as in start-up step 5.
4. Plant is “Off”.



NOTE



The ERV portion of the FRESH-PAK can be switched off using the BACnet. The stop sequence is executed by activating the input PrtOpModRln or the BACnet object PitShD. These functions override all other influences except the emergency control and protection control.

ERV ALARM FUNCTIONS

GENERAL

The application uses 2 different alarm classes:

An **A-Alarm** indicated as important and urgent situation. IF an A-Alarm is triggered, the unit shuts down. An **A-Alarm** must be acknowledged and can only be reset after cause of alarm is eliminated.

A **B-Alarm** indicates a less urgent maintenance incident and during active B-Alarm, the unit runs either normally or is still in acceptable conditions to run (without major problems).

The installer can configure alarm for certain errors and can chose between A-Alarm, B-Alarm or no alarm. Alarms must be acknowledged and as soon as the cause for each alarm is eliminated, normal operation is resumed. If one or more reasons still exist, acknowledgement does not rest that specific alarm and operation might not continue normally. All alarms are shown with a time stamp and entry to nonvolatile storage for each “change of state”. Five different alarm state are used in the application and they are valid for both A and B-alarms. These different states are meant to give additional information for different users and different situations. Relay operation is depending on actual configuration.



NOTE



See Troubleshooting section for additional alarm details.

For more information on ERV Alarm Function please see the **TROUBLESHOOTING** Section.

CONTROLS (continued)

BLOWER SPEED CONTROL

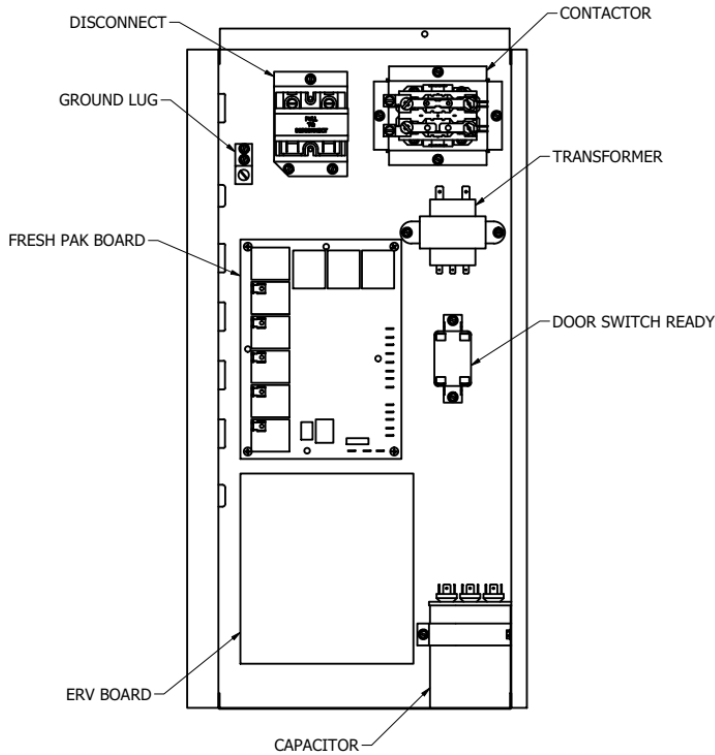

FIGURE 25 - Controls Box Detail

FRESH-PAK units are equipped with a direct drive ECM blower motor. See the **BLOWER DATA** section for airflow at different external static pressure. Select the motor speed according to the airflow and external static pressure. See wiring diagram located on unit.

For FRESH-PAK models, the default motor tap selections can be changed by directly changing the speed tap at the motor terminal.



WARNING



ELECTRIC SHOCK HAZARD



High efficiency brushless DC motors are wired with power applied at all times, see illustration above.
Low voltage thermostat demand and board algorithms will control its use.

BLOWER DATA

| EFE BLOWER DATA | | | | | | | | | | | | |
|-----------------|-----------|-------------|---------------------|-----|------|-----|------|-----|------|-----|------|-----|
| MODEL | Motor Tap | Motor Speed | IWC STATIC PRESSURE | | | | | | | | | |
| | | | 0.10 | | 0.20 | | 0.30 | | 0.40 | | 0.50 | |
| | | | SCFM | W | SCFM | W | SCFM | W | SCFM | W | SCFM | W |
| EFE12203 | 1 | T1H | 446 | 66 | 421 | 70 | 398 | 75 | 376 | 80 | 352 | 84 |
| | 2 | T2C | 478 | 77 | 453 | 82 | 429 | 86 | 408 | 41 | 384 | 95 |
| | 3 | T3 | 535 | 101 | 510 | 105 | 487 | 110 | 465 | 41 | 441 | 119 |
| EFE12205 | 1 | T1H | 477 | 86 | 464 | 93 | 448 | 100 | 430 | 105 | 412 | 108 |
| | 2 | T2C | 446 | 73 | 433 | 81 | 417 | 87 | 399 | 41 | 381 | 95 |
| | 3 | T3 | 505 | 98 | 492 | 106 | 476 | 112 | 458 | 41 | 440 | 121 |
| EFE182205 | 1 | T1H | 703 | 126 | 663 | 126 | 637 | 129 | 604 | 129 | 570 | 126 |
| | 2 | T2C | 749 | 146 | 709 | 146 | 683 | 149 | 651 | 149 | 617 | 146 |
| | 3 | T3 | 832 | 189 | 792 | 189 | 766 | 191 | 734 | 191 | 700 | 189 |
| EFE182207 | 1 | T1H | 792 | 167 | 752 | 167 | 726 | 170 | 694 | 170 | 660 | 167 |
| | 2 | T2C | 749 | 146 | 709 | 146 | 683 | 149 | 651 | 149 | 617 | 146 |
| | 3 | T3 | 832 | 189 | 792 | 189 | 766 | 191 | 734 | 191 | 700 | 189 |
| EFE182210 | 1 | T1H | 901 | 233 | 861 | 234 | 835 | 236 | 803 | 236 | 769 | 233 |
| | 2 | T2C | 749 | 146 | 709 | 146 | 683 | 149 | 651 | 149 | 617 | 146 |
| | 3 | T3 | 832 | 189 | 792 | 189 | 766 | 191 | 734 | 191 | 700 | 189 |
| EFE24205 | 1 | T1H | 749 | 146 | 709 | 146 | 683 | 149 | 651 | 149 | 617 | 146 |
| | 2 | T2C | 901 | 233 | 861 | 234 | 835 | 236 | 803 | 236 | 769 | 233 |
| | 3 | T3 | 931 | 255 | 891 | 255 | 865 | 257 | 832 | 257 | 798 | 255 |
| EFE24207 | 1 | T1H | 868 | 211 | 828 | 211 | 802 | 214 | 770 | 214 | 736 | 211 |
| | 2 | T2C | 901 | 233 | 861 | 234 | 835 | 236 | 803 | 236 | 769 | 233 |
| | 3 | T3 | 931 | 255 | 891 | 255 | 865 | 257 | 832 | 257 | 798 | 255 |
| EFE24210 | 1 | T1H | 956 | 274 | 916 | 275 | 890 | 277 | 857 | 277 | 823 | 275 |
| | 2 | T2C | 901 | 233 | 861 | 234 | 835 | 236 | 803 | 236 | 769 | 233 |
| | 3 | T3 | 931 | 255 | 891 | 255 | 865 | 257 | 832 | 257 | 798 | 255 |
| EFE30205 | 1 | T1H | 873 | 215 | 843 | 215 | 802 | 209 | 771 | 204 | 728 | 194 |
| | 2 | T2CL | 767 | 155 | 736 | 154 | 696 | 148 | 665 | 143 | 622 | 134 |
| | 3 | T3CH | 981 | 287 | 950 | 287 | 910 | 281 | 879 | 276 | 836 | 266 |
| EFE30207 | 1 | T1H | 922 | 247 | 891 | 246 | 851 | 240 | 820 | 235 | 776 | 226 |
| | 2 | T2CL | 767 | 155 | 736 | 154 | 696 | 148 | 665 | 143 | 622 | 134 |
| | 3 | T3CH | 981 | 287 | 950 | 287 | 910 | 281 | 879 | 276 | 836 | 266 |
| EFE30210 | 1 | T1H | 992 | 295 | 962 | 295 | 921 | 289 | 890 | 284 | 847 | 274 |
| | 2 | T2CL | 767 | 155 | 736 | 154 | 696 | 148 | 665 | 143 | 622 | 134 |
| | 3 | T3CH | 981 | 287 | 950 | 287 | 910 | 281 | 879 | 276 | 836 | 266 |

TABLE 13

^cFactory Default Cooling and heat Pump Airflow, L denotes Low speed and H denotes High speed for Two Stage units

^HFactory Default Electric Heat Airflow

T3 is reserved for high static operation

Blower performance data based on a dry coil at 70 degrees Fahrenheit DB EAT with standard 1" clean air filter

BLOWER DATA (continued)

| EFW BLOWER DATA | | | | | | | | | | | | |
|-----------------|-----------|------------------|---------------------|-----|------|-----|------|-----|------|-----|------|-----|
| MODEL | Motor Tap | Motor Speed | IWC STATIC PRESSURE | | | | | | | | | |
| | | | 0.10 | | 0.20 | | 0.30 | | 0.40 | | 0.50 | |
| | | | SCFM | W | SCFM | W | SCFM | W | SCFM | W | SCFM | W |
| EFW122R | 1 | T1 ^H | 446 | 66 | 421 | 70 | 398 | 75 | 376 | 80 | 352 | 84 |
| | 2 | T2 ^C | 478 | 77 | 453 | 82 | 429 | 86 | 408 | 41 | 384 | 95 |
| EFW1822R | 1 | T1 ^H | 660 | 110 | 624 | 112 | 595 | 112 | 560 | 110 | 528 | 108 |
| | 2 | T2 ^C | 739 | 141 | 702 | 143 | 674 | 144 | 638 | 142 | 606 | 140 |
| EFW1823R | 1 | T1 ^H | 744 | 148 | 709 | 149 | 681 | 150 | 648 | 148 | 611 | 144 |
| | 2 | T2 ^C | 744 | 148 | 709 | 149 | 681 | 150 | 648 | 148 | 611 | 144 |
| EFW2422R | 1 | T1 ^H | 839 | 193 | 803 | 195 | 774 | 195 | 739 | 193 | 707 | 191 |
| | 2 | T2 ^C | 895 | 228 | 859 | 230 | 830 | 230 | 795 | 228 | 762 | 226 |
| EFW2423R | 1 | T1 ^H | 893 | 233 | 858 | 234 | 830 | 235 | 797 | 233 | 759 | 229 |
| | 2 | T2 ^C | 893 | 233 | 858 | 234 | 830 | 235 | 797 | 233 | 759 | 229 |
| EFW3022R | 1 | T1 ^H | 916 | 250 | 883 | 247 | 850 | 243 | 811 | 234 | 767 | 224 |
| | 2 | T2 ^{CL} | 761 | 159 | 728 | 156 | 695 | 151 | 655 | 143 | 612 | 133 |
| | 3 | T2 ^{CH} | 991 | 302 | 958 | 299 | 925 | 294 | 886 | 286 | 842 | 276 |
| EFW3023R | 1 | T1 ^H | 992 | 304 | 954 | 300 | 921 | 294 | 882 | 287 | 839 | 277 |
| | 2 | T2 ^{CL} | 776 | 168 | 738 | 164 | 705 | 159 | 667 | 151 | 623 | 141 |
| | 3 | T2 ^{CH} | 992 | 304 | 954 | 300 | 921 | 294 | 882 | 287 | 839 | 277 |

TABLE 14

FIELD ERV ACCESSORIES

FIELD ERV ACCESSORIES CONNECTIONS

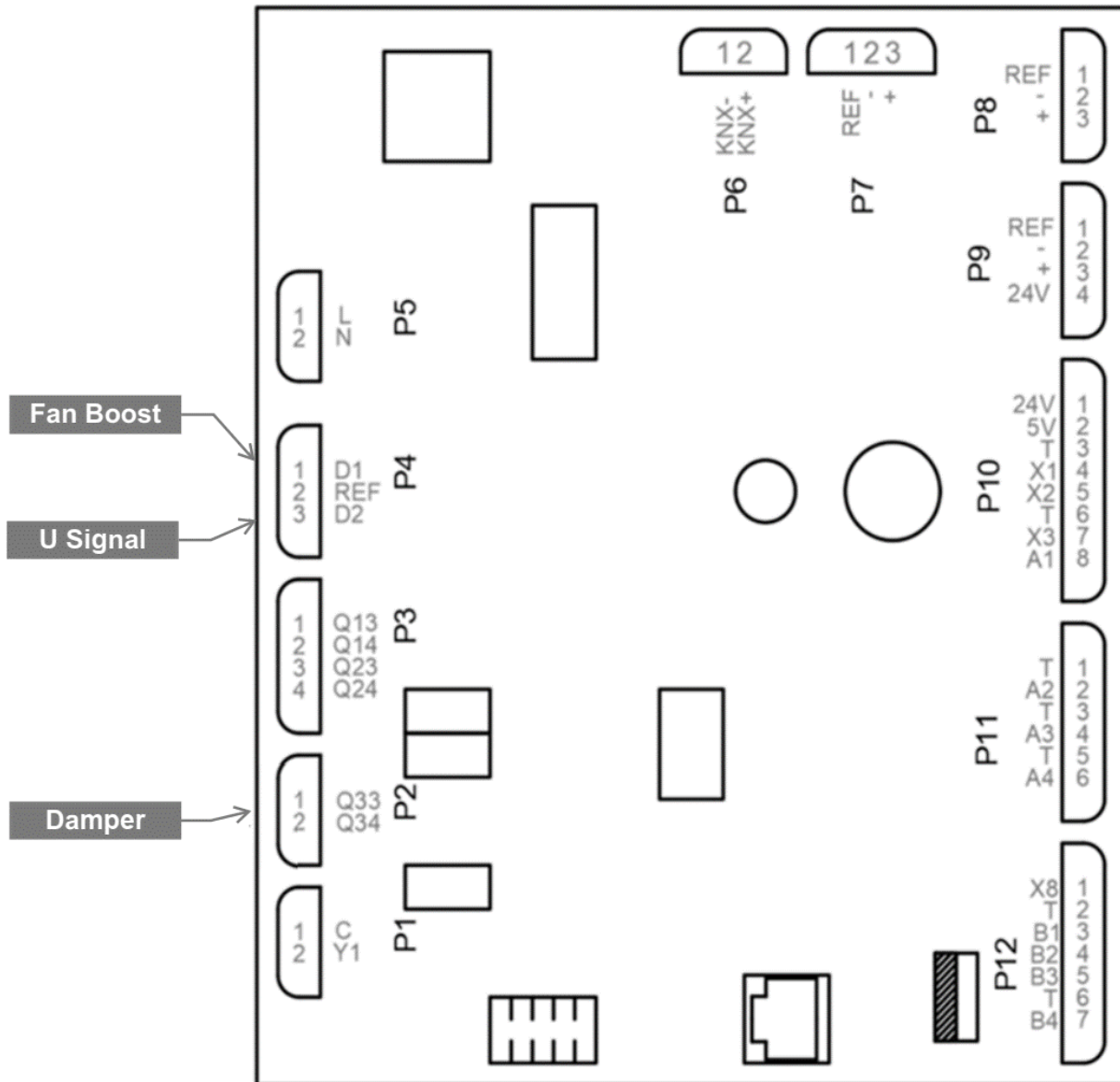

FIGURE 26 - Field ERV Accessories Connections

FIELD ERV ACCESSORIES (continued)

VERSION 2 (DIGITAL)

1. Power down FRESH-PAK unit.
2. Refer to the Installation instructions provided with the 120V digital timer switch. The switch will require its own 120v power source.
3. Find the 120V relay in the FRESH-PAK control box. Refer to the applicable wiring diagram.
4. Connect the R connection of the timer switch to the 120V pole on the relay.
5. Connect the NEUTRAL side of the timer switch to the remaining pole on the 120V relay (
6. **FIGURE 29 - Version 2 (120V Digital Timer Connection).**
7. Reenergize the FRESH-PAK unit.
8. Once the ERV restarts (about 1-2 minutes) activate the timer and confirm the ERV fans go

CO2/Humidity Sensor

1. Power down FRESH-PAK unit.
2. Refer to the Installation instructions provided with the 24V Sensor.
3. For sensors with 0-10V PWM fan control use connection A shown in **Figure 30 – Humidity/CO2 Sensor**. For 24V relay activation of fans use the B connections. Insert sensor wires into specified terminals. **DO NOT REMOVE ANY EXISTING WIRES FROM ERV CONTROLLER**
4. Connect the 24V power for the sensor to the R terminal and the 24V Common to the C terminal of the thermostat
5. Reenergize the FRESH-PAK unit.
6. Once the ERV restarts (about 1-2 minutes) Test the sensor to ensure fan operation.

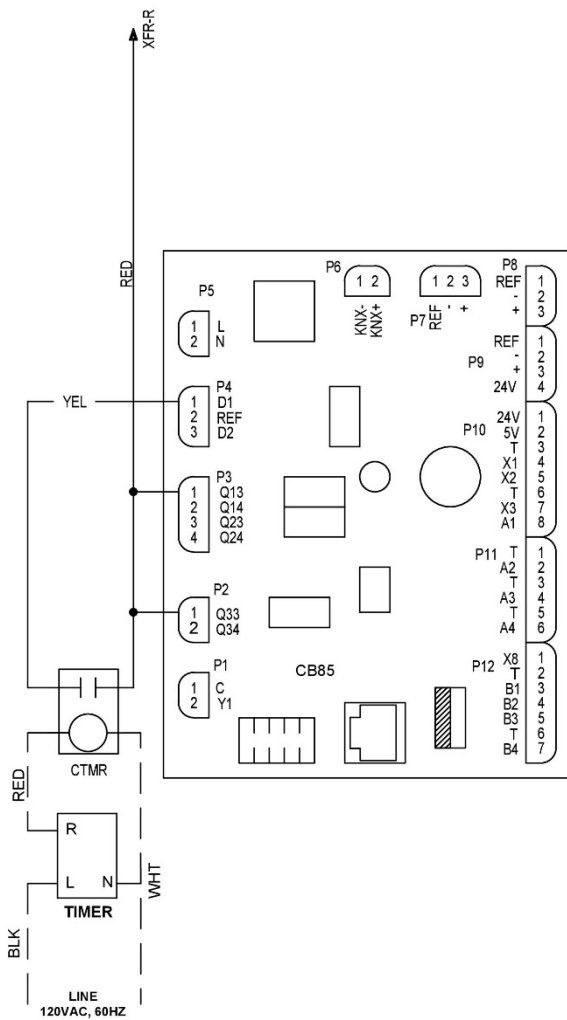

FIGURE 29 - Version 2 (120V Digital Timer Connection)

Notes: See WD85X001 For ERV Control Reference

- A: For 0-10V PWM control of ERV Fan
- B: For 24V Relay Activation of ERV FAN

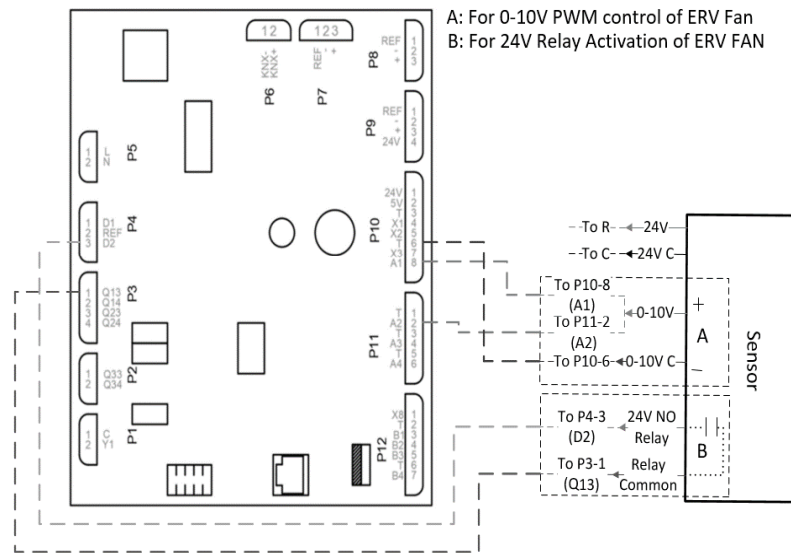

Figure 30 – Humidity/CO2 Sensor

LOCATION OF MAJOR COMPONENTS

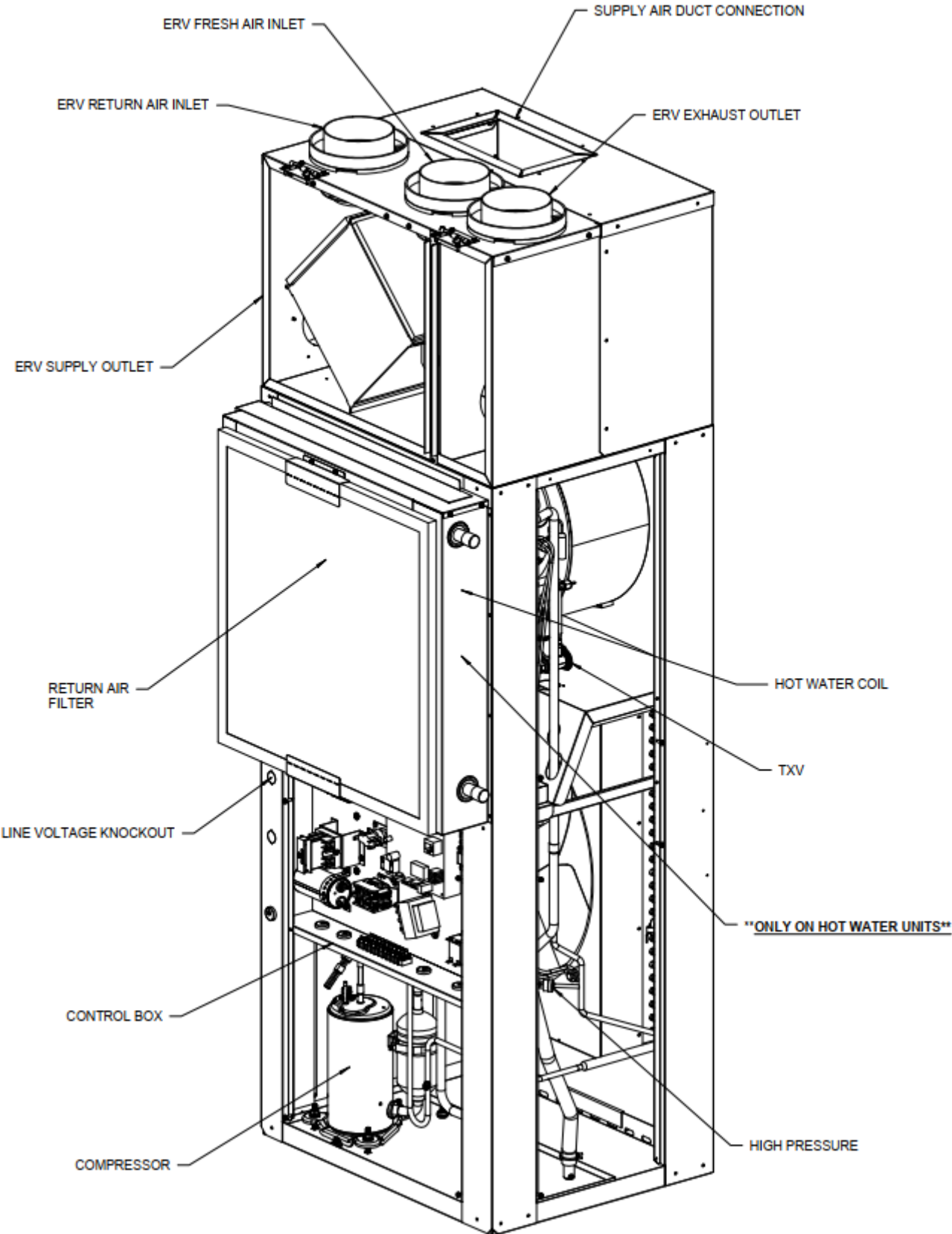

FIGURE 31 - Location of Major Components

WIRING DIAGRAMS

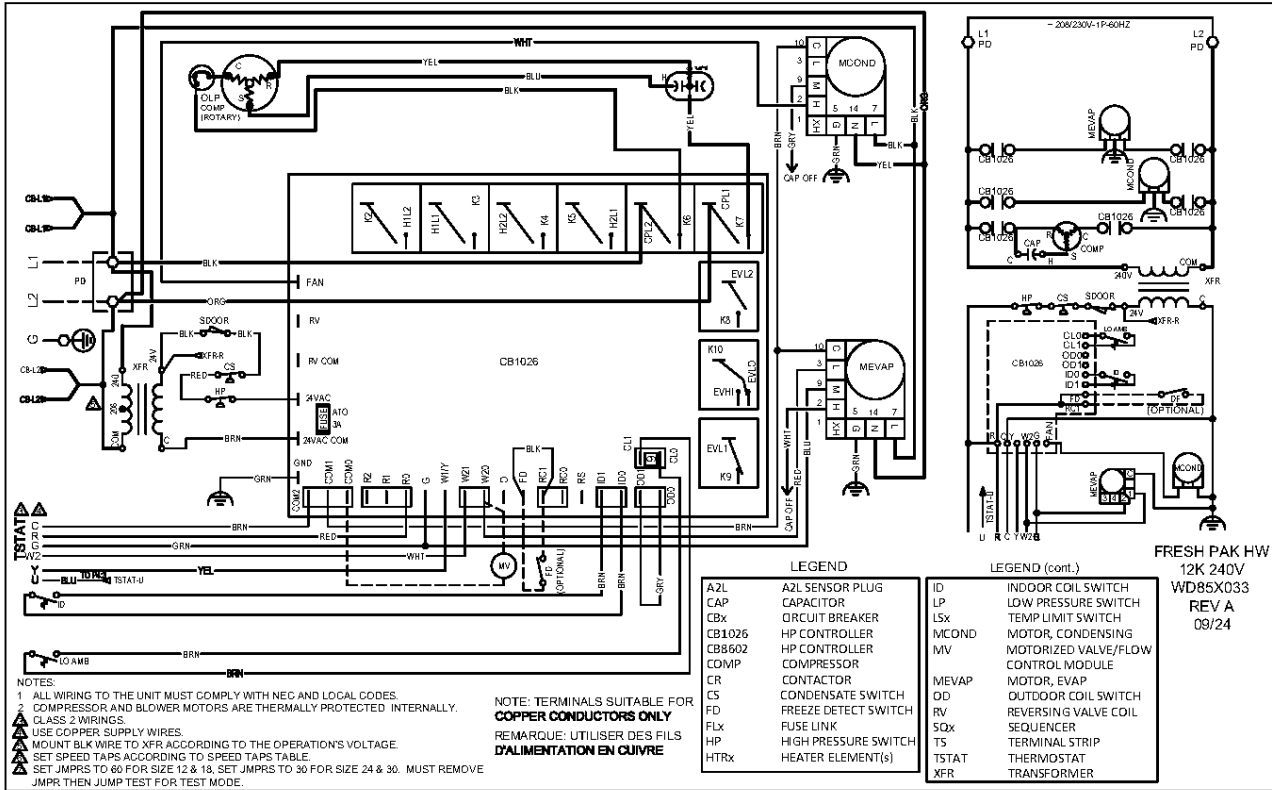

Figure 32 - Fresh Pak HW 12K 240V

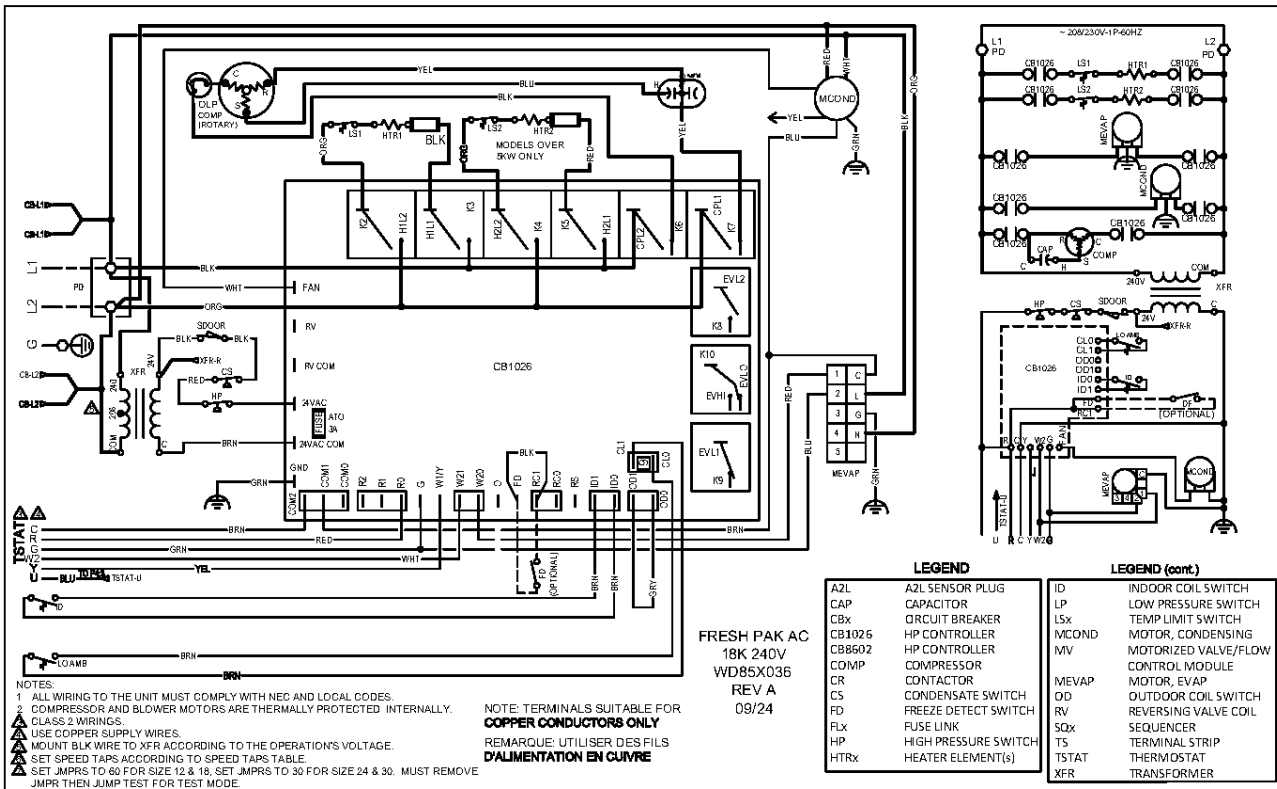

Figure 33 - Fresh Pak AC 18K 240V

WIRING DIAGRAMS

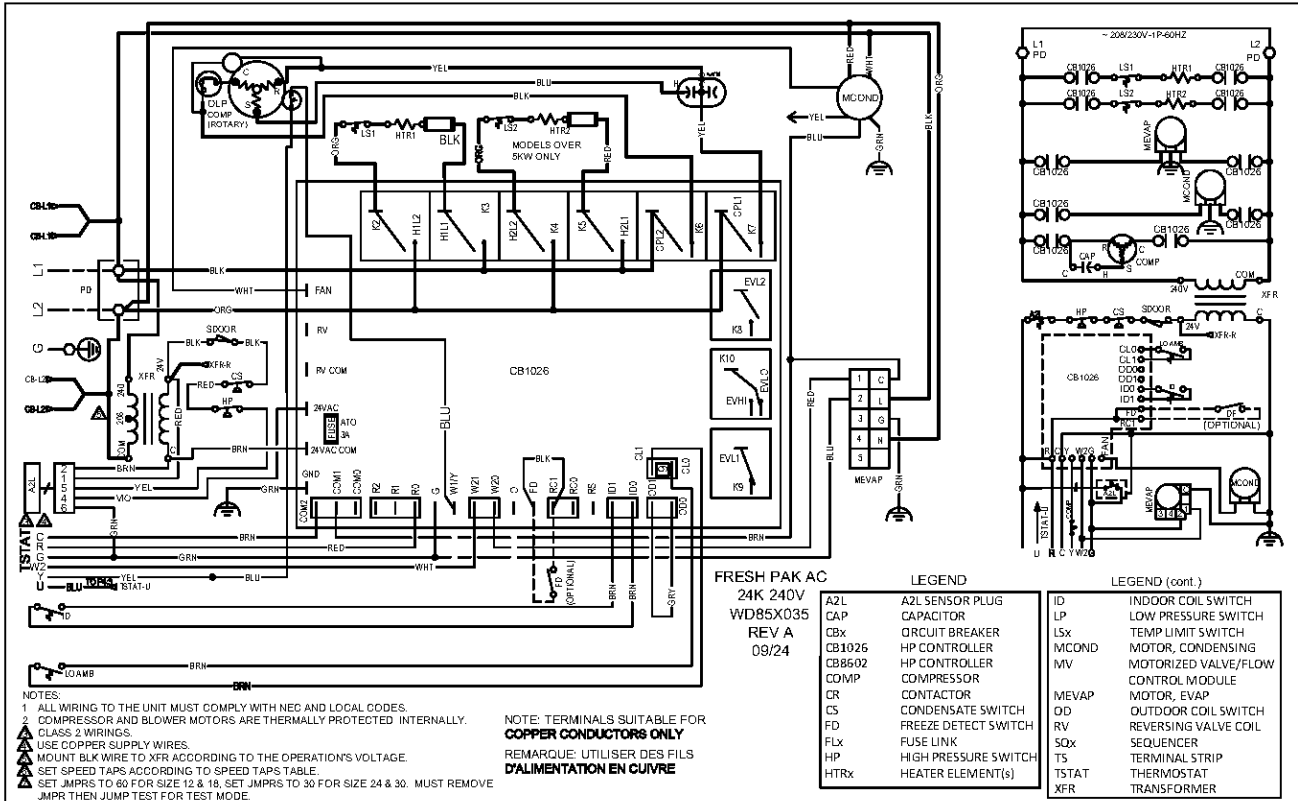

Figure 34 - Fresh Pak AC 24K 240V

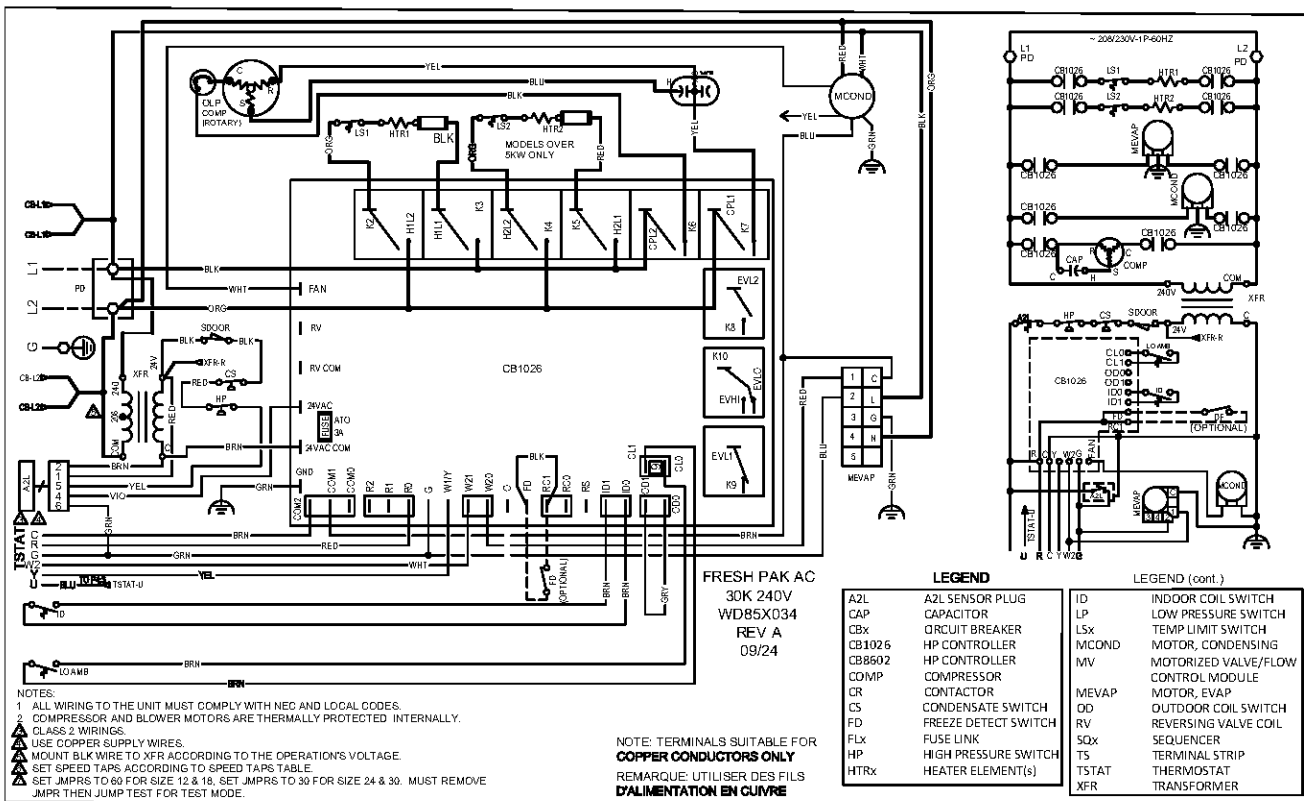

Figure 35 - Fresh Pak AC 30K 240V

WIRING DIAGRAMS

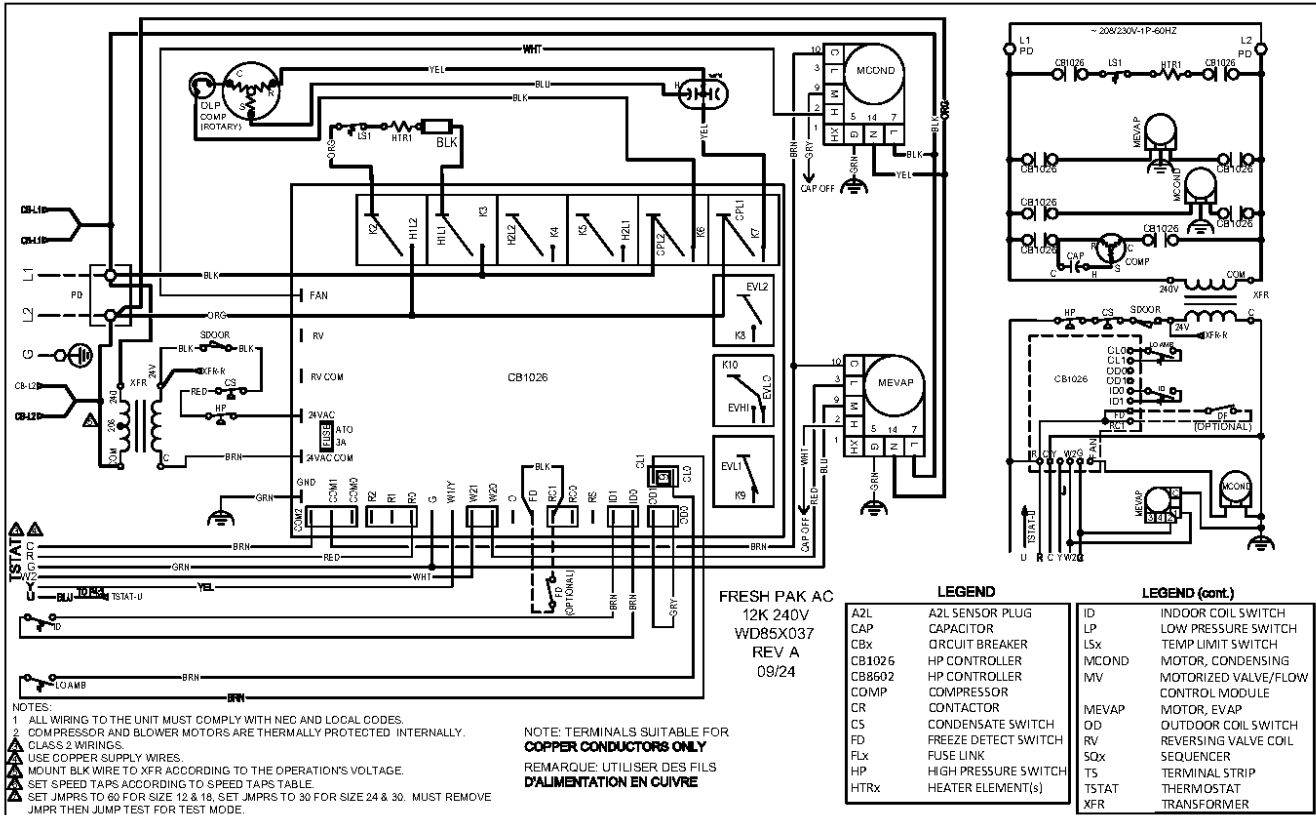

Figure 36 - Fresh Pak AC 12K 240V

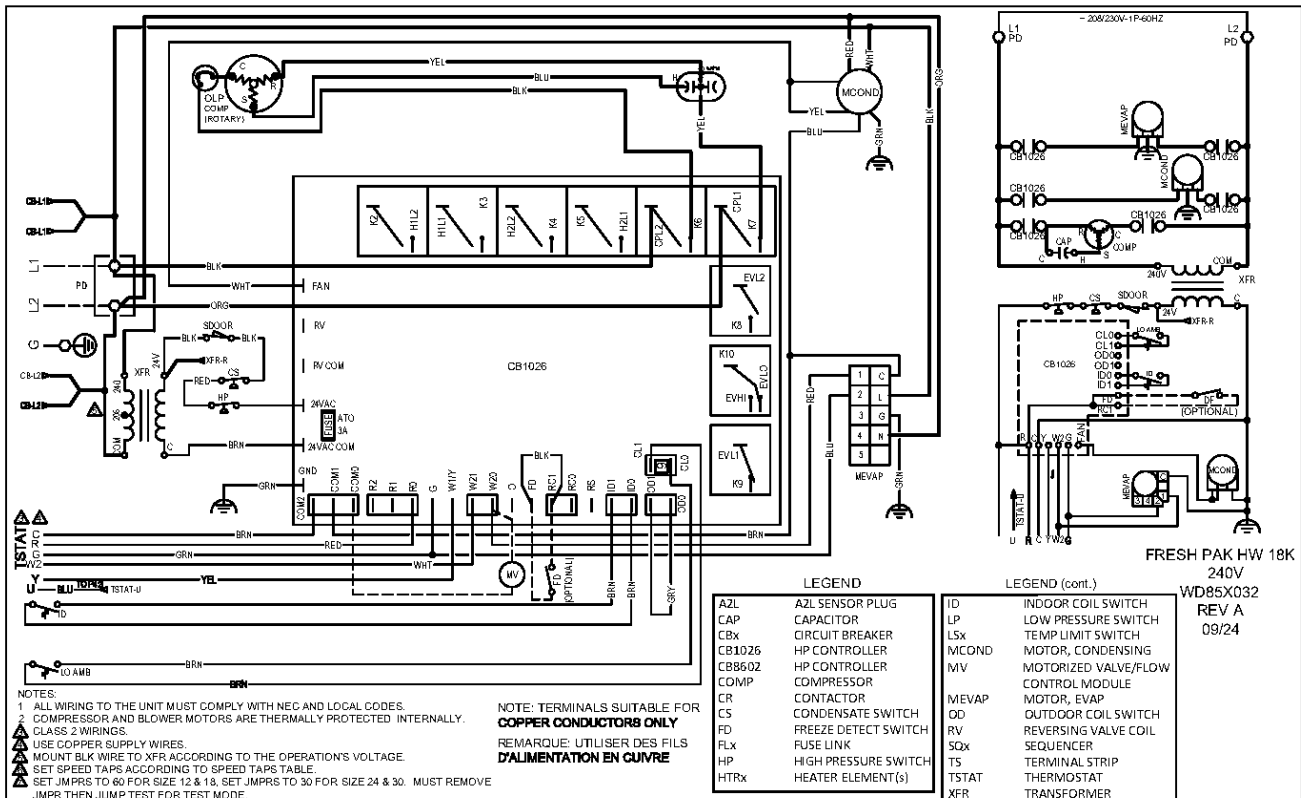

Figure 37 - Fresh Pak HW 18K 240V

CIRCUIT SCHEMATIC

COOLING & HOT WATER ONLY

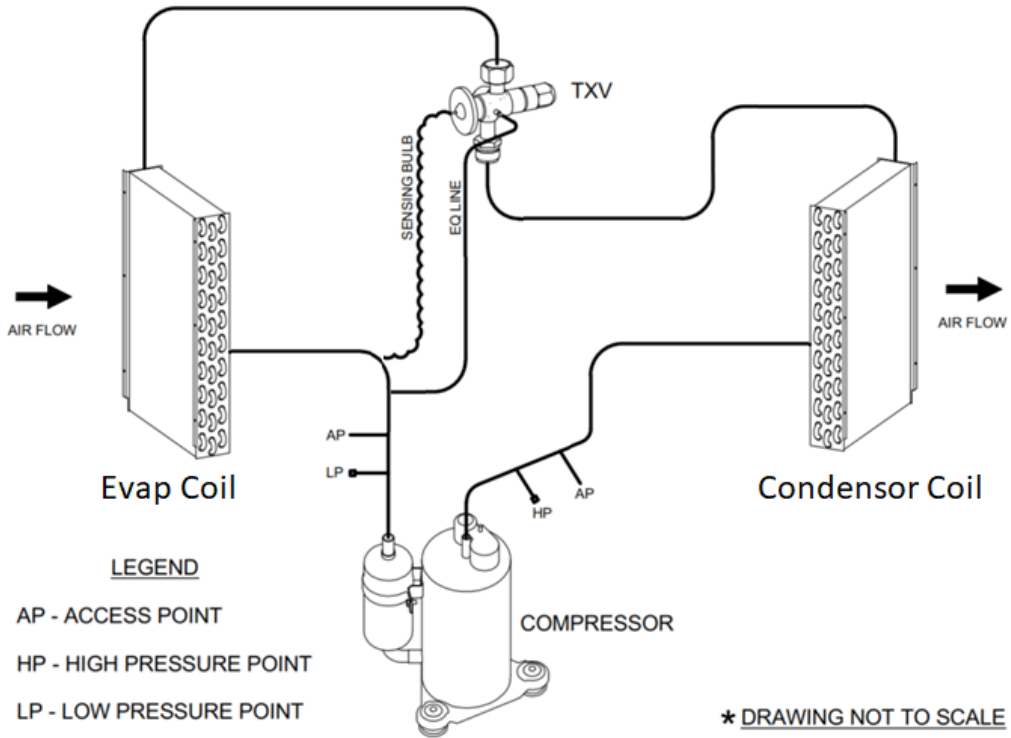

FIGURE 40 - Circuit Schematic (Cooling & Hot Water)

STARTUP INSTRUCTIONS

PRE-STARTUP CHECKS

Before start-up, thoroughly check all the components. Optimal operation of equipment requires cleanliness. Often after installation of the equipment, additional construction activities occur. Protect the equipment from debris during these construction phases.

WARNING

FIRE OR EXPLOSION HAZARD

IMPROPER HANDLING OF REFRIGERANTS CAN CAUSE INJURY, EXPLOSION AND DEATH

- It is illegal to release refrigerant into the atmosphere. Refrigerant released into an enclosed space will displace oxygen causing unconsciousness and death.
- If an indoor refrigerant leak is suspected, thoroughly ventilate the area before beginning any work
- DO NOT purge or allow refrigerant to be released into an interior space
- Contact with liquid refrigerant can cause frostbite and blindness. Avoid skin contact with liquid refrigerant, wear goggles and gloves when working with refrigerants. Seek medical help immediately if any refrigerant contact with skin or eyes occurs
- Never burn refrigerant as highly toxic gas will be produced
- Only EPA certified technicians should handle refrigerants.
- In Canada technicians must be ODP / ODS certified to handle refrigerants
- Follow all EPA regulations

WARNING

Do not supply power to unit with the compressor terminal box cover removed.

WARNING

ELECTRIC SHOCK HAZARD

Disconnect all power supplies before servicing. Lock out/tag out to prevent accidental electrical shock.

WARNING

Install all parts and panels before operation of unit. Failure to follow these warnings can result in injury or death.

CAUTION

Wire any field installed device such as a fan switch or thermostat furnished by the factory in strict accordance with the wiring diagram supplied with the unit. Failure to properly wire the unit could result in damage to components and will void all warranties.

WARNING

Do not exceed the maximum operating pressure listed on the unit rating plate.

STARTUP INSTRUCTIONS



WARNING



ELECTRIC SHOCK HAZARD

Transformers are multi voltage, It is crucial to refer to unit wiring diagram, transformers wiring diagram as well as unit voltage to ensure proper connections and operation safety.

PRIOR TO THE STARTUP OF THE UNIT

1. Ensure supply voltage matches nameplate data.
2. Ensure the unit is properly grounded
3. With the power off, check blower wheel set screws for proper tightness and that the blower wheel rotates freely.
4. Ensure unit will be accessible for servicing.
5. Ensure condensate line is properly sized, run, trapped, pitched and tested.
6. Ensure all cabinet openings and wiring connections have been sealed.
7. Ensure clean filters are in place.
8. Ensure all access panels are in place and secured.
9. Ensure that all air has been vented from the water coil.
10. Verify that all electrical connections are tight and secure.
11. Check the electrical overcurrent protection and wiring for the correct size.
12. Verify that the low voltage wiring between the thermostat and the unit matches the wiring diagram.
13. Verify that the water piping is complete and correct.
14. Check condensate overflow sensor for proper operation and adjust position if required.

FRESH-PAK COOLING/ELECTRIC HEAT UNITS

1. Set thermostat system switch to "OFF" position and fan switch to "Auto" position. Apply power to the FRESH-PAK Unit.



NOTE



The FRESH-PAK employs a random reset timer which delays unit operation up to 60 seconds following initial power application. Electronic thermostats may also employ internal reset timers which may further delay any changes which are made to the operation of the unit.

2. Set fan switch to "On", indoor blower should operate after the reset timer cycle is complete.
3. Return fan switch to "Auto", indoor blower should de-energize.
4. Set system switch to "Cool" and lower the thermostat set point to coldest setting. The compressor should energize as well as the outdoor fan and indoor blower.



NOTE



The FRESH-PAK employs a compressor short cycle delay (approx. 6 minutes) which will not allow the compressor to immediately restart following shut down. Additional delays may be experienced if using an electronic digital thermostat.

5. Return thermostat set point to a temperature warmer than a room temperature and the compressor and outdoor fan should de-energize. The indoor blower should remain in operation for an additional 45 seconds, then de-energize.
6. Move system switch to "Heat" and raise thermostat to a set point higher than room temperature. The indoor blower and electric heating element(s) should energize.
7. Return system switch to "Off" position.



NOTE



The FRESH-PAK employs a random reset timer which delays unit operation up to 60 seconds following initial power application. Electronic thermostats may also employ internal reset timers which may further delay any changes which are made to the operation of the unit.

STARTUP INSTRUCTIONS (continued)



NOTE



The FRESH-PAK employs a compressor short cycle delay (approx. 6 minutes) which will not allow the compressor to immediately restart following shut down. Additional delays may be experienced if using an electronic digital thermostat.



NOTE



The FRESH-PAK employs a compressor lock out which will not allow the compressor and electric heaters to energize at the same time.



NOTE



The FRESH-PAK features a low ambient compressor lock out switch, which limits the refrigerant system operation when the sensor detects a temperature less than 40°F in the outdoor section of the cabinet.

FRESH-PAK COOLING WITH HOT WATER UNITS

1. Set thermostat system switch to “Off” position and fan switch to “Auto” position. Apply power to the FRESH-PAK HW unit.



NOTE



The FRESH-PAK employs a random reset timer which delays unit operation up to 60 seconds following initial power application. Electronic thermostats may also employ internal reset timers which may further delay any changes which are made to the operation of the unit.

2. Set fan switch to “On”, indoor blower should operate after the rest timer cycle is complete.
3. Return fan switch to “Auto”, indoor blower should de-energize.
4. Set system switch to “Cool” and lower thermostat set point to coldest setting. The compressor should energize as well as the outdoor fan and the indoor blower.
5. Return thermostat set point to a temperature warmer than a room temperature and the compressor and outdoor fan should de-energize. The indoor blower should remain in operation for an additional 45 seconds, then de-energize.
6. Move system switch to “Heat” and raise the thermostat to a set point higher than room temperature. The indoor blower and field supplied motorized valve should energize.

7. Lower the set point to less than room temperature and the system should de-energize.
8. Return system switch to “Off” position.

STARTUP & PERFORMANCE CHECKLIST INSTRUCTIONS:

The warranty may be void unless is completed and returned to the warrantor. If the unit is not installed properly the warranty will be void as the manufacturer will not be held accountable for problems that stem from improper installation.



WARNING



- Always wear eye protection.
- When fan coil is operating, some components are operating at high speeds. Do not touch rotating items with any object
- Return and secure all electrical and service access panels in their proper place.
- Clear surrounding area of all tools, equipment and debris.
- Check the entire unit to ensure its cleanliness.

TROUBLESHOOTING

| PROBLEM | POSSIBLE CAUSE | CHECKS & CORRECTIONS |
|---------------------------------------------|-----------------------------|-------------------------------------------------------------------------------------------------------------------------------------------------------------------------------------------------------------------------------------------------------------------------------------------------------------------------------------------------------------------------------------------------------------------------------------------------------------------------------------------------------------------------------------------------|
| ENTIRE UNIT DOES NOT RUN | Power supply off | Apply power; close disconnect. |
| | Blown Fuse | Replace fuse or reset circuit breaker. Check for correct fuses. |
| | Voltage supply low | If voltage is below minimum voltage specified on unit data plate, contact lower power company. |
| | Thermostat | Set the fan to "ON", the fan should run. Set thermostat to "COOL" and lowest temperature setting, the unit should run in the cooling mode. If neither the blower nor compressor run in either case, the thermostat could be mis-wired or faulty. To ensure mis-wired or faulty thermostat verify 24 volts is available on the condenser section low voltage terminal strip between "R" and "C", "Y" and "C". If blower does not operate, verify 24 volts between terminals "G" and "C" in the air handler. Replace the thermostat if defective. |
| BLOWER OPERATES BUT COMPRESSOR DOES NOT RUN | Thermostat | Check setting, calibration and wiring. |
| | Wiring | Check for loose or broken wires at compressor, capacitor or contractor. |
| | Compressor overload open | If the compressor is cool and the overload will not reset, replace the compressor. |
| | Compressor motor grounded | Internal wiring grounded to the compressor shell. Replace compressor. If compressor burnout, install new filter dryer. |
| | Compressor windings open | After compressor has cooled, check continually of compressor windings. If the windings are open, replace the compressor. |
| | Refrigerant Sensor | For units over 4lbs, an active refrigerant leak or faulty sensor will disable the compressor operation. Verify absence of refrigerant leak and replace sensor. |
| UNIT OFF ON HIGH PRESSURE CONTROL | Discharge pressure too high | In "COOLING" mode: Lack of or inadequate water flow. Entering water temperature too warm. Scaled or restricted water to refrigerant heat exchanger. |
| | Refrigerant charge | The unit is overcharged with refrigerant. Reclaim refrigerant, evacuate and recharge with factory recommended charge. |
| | High pressure switch | Check for defective or improperly calibrated high-pressure switch. |
| UNIT OFF ON LOW PRESSURE CONTROL | Suction Pressure too low | In "COOLING" mode: Lack of or inadequate airflow. Entering air temperature too cold. Blower inoperative, clogged filter or restriction in ductwork. |
| | Refrigerant charge | The unit is low on refrigerant. Check for refrigerant leak, repair, evacuate and recharge with factor recommended charge. |
| | Low pressure switch | Check for defective or improperly calibrated low-pressure switch. |
| UNIT SHORT CYCLES | Unit oversized | Recalculate heating and cooling loads. |
| | Thermostat | Thermostat installed near a supply air register, relocate thermostat. Check heat anticipator. |
| | Wiring and controls | Loose connections in the wiring or a defective compressor contactor. |
| A2L SENSOR STATUS LIGHT | Solid Green | Sensor is in startup mode. |
| | Blinking Green | Sensor is in normal operation. |
| | Solid Red | Sensor has detected a leak and is in mitigation mode. |
| | Blinking Red | Sensor fault, unit compressor will not energize and fan will be continuous. |

Table 15 - Troubleshooting Table (1 of 2)

TROUBLESHOOTING (continued)

| PROBLEM | POSSIBLE CAUSE | CHECKS & CORRECTIONS |
|---------------------------------|----------------------------------|-------------------------------------------------------------------------------------------------------------------------------------------------------------------------------|
| INSUFFICIENT COOLING OR HEATING | Unit undersized | Recalculate heating and cooling loads. If not excessive, possibly adding insulation will rectify the situation. |
| | Loss of conditioned air by leaks | Check for leaks in ductwork or introduction of ambient air through doors or windows. |
| | Airflow | Lack of adequate airflow or improper distribution of air. Replace dirty air filter. |
| | Refrigerant charge | Low on refrigerant charge causing inefficient operation. |
| | Compressor | Check for defective compressor. If discharge is too low and suction pressure is too high, compressor is not pumping properly. Replace compressor. |
| | Reversing valve | Defective reversing valve creating bypass of refrigerant from discharge to suction side of compressor. Discharge is too low and suction is too high. Replace reversing valve. |
| | Operating pressures | Compare unit operating pressures to the pressure / temperature chart for the unit. |
| | Refrigerant metering device | Check for possible restriction or defect. Replace is necessary. |
| | Moisture, non-condensable | The refrigerant system may be contaminated with moisture or non-condensable. Reclaim refrigerant, evacuate and recharge with factory recommended charge. |

Table 16 - Troubleshooting Table (2 of 2)

ERV ALARM CODES

| ALARM CODES (ERV) | | |
|------------------------|--------------------------------------------------------------------------------------------------------------------------------------------|-------------|
| STATE | SITUATION | ALARM RELAY |
| Normal | Everything works normally | Open |
| Alarm, unacknowledged | Problem detected by controller and alarm activated | Closed |
| Alarm, acknowledged | Problem still existing, service man acknowledged the active alarm | Open |
| Normal, acknowledged | Problem fixed / eliminated, alarm is acknowledged For A-Alarm: Reset pending to unlock unit For B-Alarm: Works normal. | Open |
| Normal, unacknowledged | Problem fixed / eliminated, but alarm is not acknowledged | Closed |

Table 17 - Alarm Codes (ERV)

A-ALARMS

In the case of critical A-Alarms, the application operation is locked in shut down mode until the alarm is acknowledged and reset.

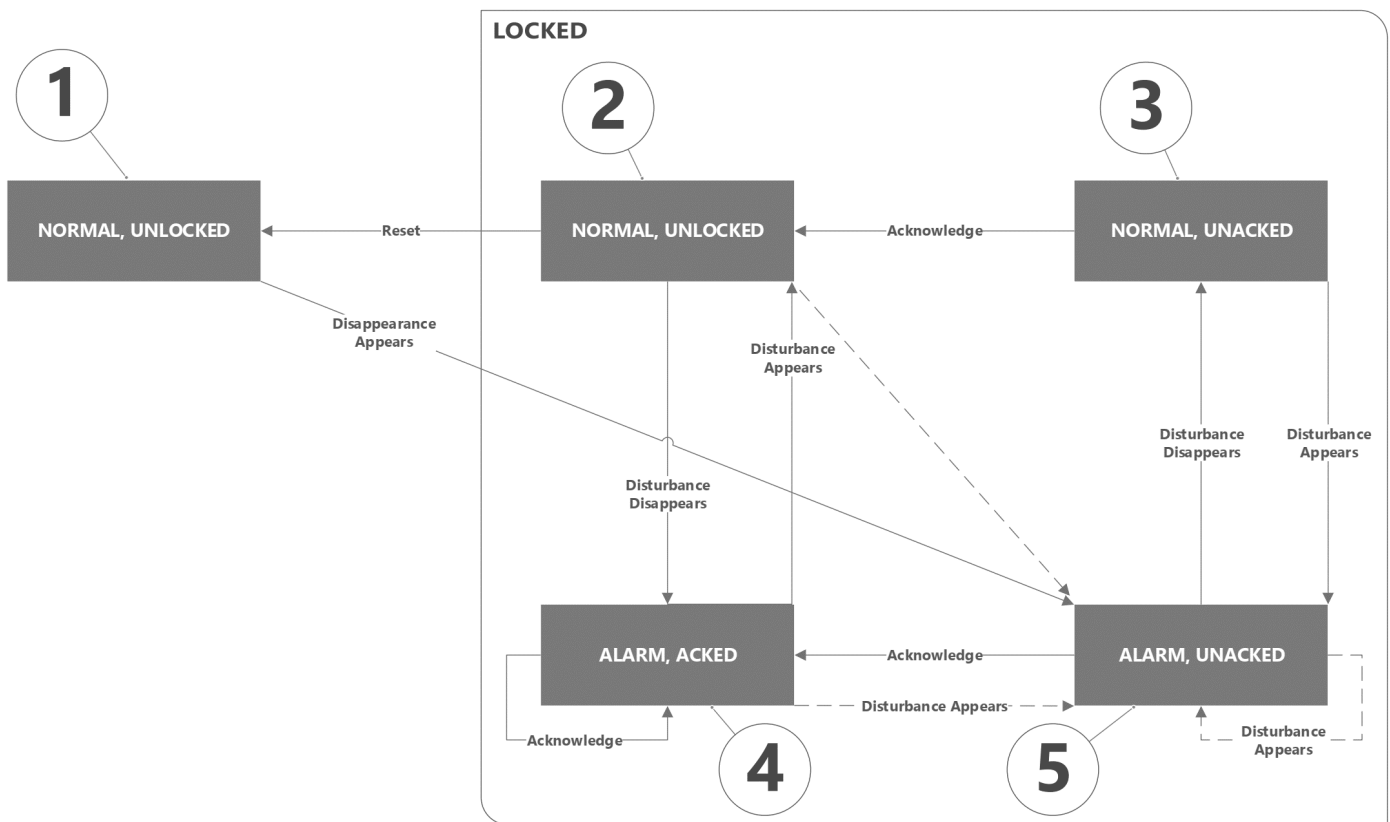

Figure 41 - A-Alarms Application Operation Key

| A-ALARMS APPLICATIONS OPERATION KEY | | | |
|-------------------------------------|-------|--------|----------------|
| | ALARM | LOCKED | UNACKNOWLEDGED |
| 1 | 0 | 0 | 0 |
| 2 | 0 | 1 | 0 |
| 3 | 0 | 1 | 1 |
| 4 | 1 | 1 | 0 |
| 5 | 1 | 1 | 1 |

Table 18 - A-Alarms Application Operation Key

ERV ALARM CODES (continued)

B-ALARMS

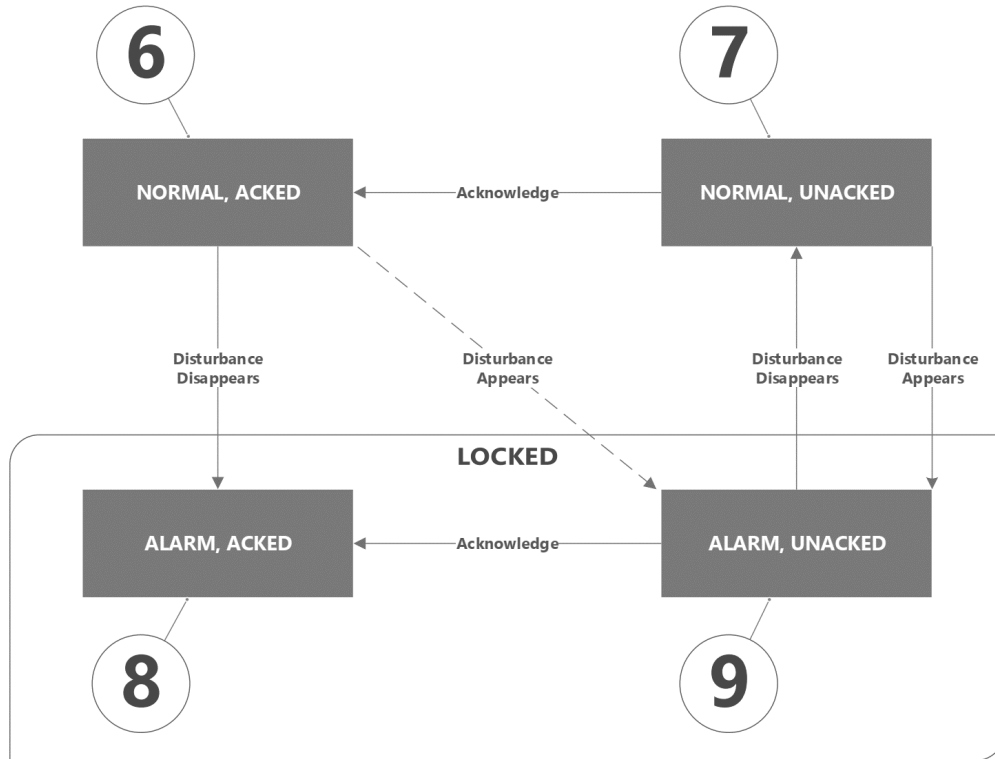

FIGURE 42 - B-Alarms Application Operation Key

| B-ALARMS APPLICATIONS OPERATION KEY | | | |
|-------------------------------------|-------|--------|----------------|
| | ALARM | LOCKED | UNACKNOWLEDGED |
| 1 | 0 | 0 | 0 |
| 2 | 0 | 1 | 0 |
| 3 | 0 | 1 | 1 |
| 4 | 1 | 1 | 0 |
| 5 | 1 | 1 | 1 |

Table 19 - B-Alarms Application Operation Key

ERV ALARM CODES (continued)

AVAILABLE PARAMETERS

| AVAILABLE PARAMETERS | | | |
|---------------------------------------------------------------------------------------------|-------------------------|------|----------------------------------------------------------------------------------------------------|
| ACKNOWLEDGE AND RESET | BACNET OBJECT | R/RW | NOTE |
| A-Alarm acknowledgement | AalmAck MVAL,137 | RW | 1: Ready 2: Acknowledge 3: Reset Automatic return to 1 |
| B-Alarm acknowledgement | BalmAck MVAL,133 | RW | 1: Ready 2: Acknowledge Automatic return to 1 |
| A-ALARMS | BACNET OBJECT | R/RW | NOTE |
| A-Alarm state | AalmSta MVAL, 135 | R | 1: Acknowledged, unlocked 2: Unacknowledged 3: Reset Automatic return to 1 |
| A-Alarm indication | AalmInd MVAL, 136 | R | 1: Normal 2: Alarm |
| A-Alarm code | AalmCode AVAL, 49 | R | 0...9999 |
| B-ALARMS | BACNET OBJECT | R/RW | NOTE |
| B-Alarm state | BalmSta MVAL, 132 | R | 1: Acknowledged, unlocked 2: Unacknowledged 3: Reset Automatic return to 1 |
| B-Alarm indication | BalmInd MVAL, 131 | R | 1: Normal 2: Alarm |
| B-Alarm code | BalmCode AVAL, 43 | R | 0...9999 |
| ALARM CLASS SETTINGS | BACNET OBJECT | R/RW | NOTE |
| Alarm configuration for outside air temperature | AlmCnfTOa MVAL,141 | RW | 1: A-Alarm 2: B-Alarm |
| Alarm configuration for heat exchanger | AlmCnfHExg MVAL,348 | RW | 1: A-Alarm 2: B-Alarm 3: None |
| Alarm configuration for all fan errors (Feedback fault, error signal or Modbus interrupted) | AlmCnfFanFb MVAL,349 | RW | 1: A-Alarm 2: B-Alarm 3: None (No fan error supervision. – Do not use “None for Modbus fans) |

Table 20 - Available Parameters

Error codes are divided in different groups for easier recognition of the alarm source. Those groups are identified in the table below.

| ERROR CODES | |
|-------------|--------------------------------------|
| ERROR CODE | ERROR SOURCE |
| 1000---1999 | Hardware related errors |
| 2000---2999 | Application related errors |
| 3000---3999 | Communication errors |
| 9000---9999 | 3 rd party related errors |

Table 21 - Error Codes

ERV ALARM CODES (continued)

CODE RANGES – HARDWARE

| CODE RANGES – HARDWARE | | | | | | |
|------------------------|-------------|-------------------------------------------------------------|---------|------------|--------------------------------------------------------------------------------------------|------------------------------------------------------------------------------------------------|
| CODE | ALARM CLASS | NAME/DESCRIPTION | SOURCE | PLANT LOCK | BACNET OBJECT/COMMENT | INFLUENCE OF ALARM |
| 1001 | A | Supply air temperature, Sensor fault | System | Stop | TSu | Shutdown AHU |
| 1002 | A/B | Exhaust air temperature, sensor fault | System | Run | TEh, Active only if sensor available | Shutdown AHU/ No Heat exchanger supervision possible |
| 1003 | B | Extract air temperature, sensor fault | System | Run | TEx, Active only if sensor available | Fallback to room temperature control or supply air control |
| 1004 | A/B | Outside air temperature sensor fault | System | Conf. | TOa | Shutdown AHU / fallback to default |
| 1005 | A | Frost protection temperature for heating coil, sensor fault | System | Stop | TFrPrtHcl Active only if HclHw selected | Shutdown AHU, Frost protection mode |
| 1006 | B | Relative humidity for extract air, sensor fault | System | Run | HuRelEx, Active only if sensor available | Stop Humidity control if all sensors fail |
| 1009 | A | Fire damper position, feedback fault | Process | Stop | FdpFb, Active only if Fdp selected. Plausibility check of fire damper position feedback | Shutdown AHU |
| 1012 | B | Room Temperature, sensor fault | System | Run | TR with POS8/QMX3 | Fallback to extract temperature control or supply air control |
| 1013 | B | Room air quality, sensor fault | System | Run | AQualR with QMX3 or PmR | Stop air quality control if all sensors fail |
| 1014 | B | Extract air quality, sensor fault | System | Run | PmR or AQualR, Particulate matters, Air quality | Stop control if all sensors fail |
| 1017 | B | Room air humidity, sensor fault | System | Run | HuRelR, Active only if sensor available | Stop Humidity control if all sensors fail |
| 1018 | A/B | Supply air temp. after preheating coil, sensor fault | System | Run | TSuAfPreHcl, Active only if sensor available | Shutdown AHU / Shutdown electric preheating coil, fallback value for heat exchanger efficiency |
| 1019 | B | Flow temperature preheating coil, sensor fault | System | Run | TFIPreHcl, Active only if sensor available | Fallback to default value |
| 1020 | B | Air filter, dirty | Process | Run | Operating hour of air filter exceeds limit or delta P, active only if FilA selected | No reaction |
| 1021 | B | Supply air temperature after heat exchanger, sensor fault | System | Run | TsuAfHEXg, Active only if sensor available | Fallback value for Hexg efficiency calculation |
| 1031 | A/B/n | Heat Exchanger fault | Process | Run | RotHEXgFlt or HEXgCdnMon | Shutdown AHU / Bypass or shutdown HEXg / no reaction |
| 1037 | A/B/n | Supply air fan fault | Process | Conf. | FanSuSpdFb, FanSuFlt Check of fan speed feedback or fault signal | Shutdown AHU / No reaction / No reaction |
| 1038 | A/B/n | Exhaust air fan fault | Process | Conf. | FanSuSpdFb, FanSuFlt Check of fan speed feedback or fault signal | Shutdown AHU / No reaction / No reaction |
| 2001 | A | Emergency off | Process | Stop | EngOff (BI) | AHU off |
| 2002 | A | Smoke detector | Process | Stop | Smext (BI) | Smoke extract mode |
| 2004 | A | Fire Alarm | Process | Stop | Supply (TSu) or extract (TEx) air temperature exceeds max limit | Shutdown extract mode |
| 2005 | B | Supply air temperature, exceeds operating limits | Process | Stop | Supply air temperature (TSu) exceeds min/max limits | No reaction |
| 2012 | A | Preheating coil, over temperature | Process | Stop | PreHclOvrTDet, active only if PreHclEI selected | Shutdown AHU |
| 2013 | A | Outside air damper stops air flow | Process | Stop | | Shutdown AHU |
| 2017 | A/B/n | Heat exchanger efficiency supervision | Process | Conf. | Plausibility check of air temperatures | Shutdown AHU / Bypass or shutdown / no reaction |

Table 22 - Code Ranges - Hardware

ERV ALARM CODES (continued)

CODE RANGES – COMMUNICATION

| CODE RANGES – HARDWARE | | | | | | |
|------------------------|-------------|--------------------------------------------------|--------|------------|-----------------------------------------------------------------------------------------------------------------------|------------------------------------------------------------------------------------------|
| CODE | ALARM CLASS | NAME/DESCRIPTION | SOURCE | PLANT LOCK | BACNET OBJECT/COMMENT | INFLUENCE OF ALARM |
| 3005 | B | I/O extension module, Modbus communication fault | System | Run | POS9 active only if device configured | Same reaction as for each connection input |
| 3011 | B | Duct pressure sensor, Modbus communication error | System | Run | QBM, Active only if device configured | Fallback to linear Fan speed |
| 3012 | A/B | Supply air fan, Modbus communication fault | System | Conf. | Active only if Modbus fan configured | A: Shutdown AHU / B: No reaction Reaction of fan based on fan device configuration |
| 3101 | B | Room sensor, KNX PL-Link communication error | System | Run | Common fault for all PL-Link room devices: POS8.4420/4440, QMX3.P30/P40/P70 Active only if device configured | |

Table 23 - Code Ranges - Hardware

OPERATION & MAINTENANCE

REFRIGERANT CHARGE AND PARTIAL REFRIGERANT CHARGE

Aqua Pak units are factory charged with refrigerant. All units use an adjustable thermostatic expansion valve (txv) to control refrigerant flow to the evaporator coil. Do not adjust the txv unless an evaluation of the system as described below indicates it is necessary. Superheat is increased (decrease refrigerant flow) by turning the txv stem clockwise, turning the stem counter-clockwise will decrease superheat (increase refrigerant flow). Ideal conditions for checking refrigerant charge in cooling mode exist when the outdoor temperature is above 70°f (21° c) and indoor temperature is between 70°f (21°c) & 80°f (26.7° c).

PARTIAL REFRIGERANT CHARGE

Total refrigerant charge is listed on the unit rating plate. For partial system charging, the subcooling and superheat method can be used to make small refrigerant charge adjustments. Optionally, the entire refrigerant charge can be recovered and weighed back in per the total system charge listed on the rating plate. To check the refrigerant charge, actual subcooling & superheat must be determined. Allow the unit to operate in cooling mode for 15 minutes before taking readings. Attach refrigerant gauges to the suction line and liquid line access ports.

Subcooling

- 1) Place an accurate temperature sensor on the liquid line as close as practical to the TXV inlet. Insulate the temperature sensor from ambient to assure an accurate line temperature reading.
- 2) Record the liquid line temperature
- 3) Record the saturated temperature on your liquid line gauge that corresponds to the pressure shown on your gauge.

Actual Subcooling = saturated liquid line temperature - liquid line temperature

Superheat

- 1) Place an accurate temperature sensor on the suction line as close as practical to the compressor. Insulate the temperature sensor from ambient to assure an accurate line temperature reading
- 2) Record the suction line temperature
- 3) Record the saturated temperature on your suction line gauge that corresponds to the pressure shown on your gauge

Actual superheat = suction line temperature - saturated suction temperature

Compare your actual subcooling and superheat to the target subcooling and superheat.

If subcooling and superheat are both low, adjust the TXV stem clockwise 1/4 turn. Allow the system to stabilize before re-checking.

If subcooling is low and superheat is high, add a small amount of refrigerant. Allow the system to stabilize before re-checking.

If subcooling and superheat are both high, adjust the TXV stem counter-clockwise 1/4 turn. Allow the system to stabilize before re-checking.

If subcooling is high and superheat is low, adjust the TXV stem 1/4 turn clockwise. Recover a small amount of refrigerant. Allow the system to stabilize before re-checking.

| Cooling Capacity | 12K | 18K | 24K | 30K |
|-------------------------|-----|-----|-----|-----|
| Subcooling | 8 | 8 | 16 | 10 |
| Superheat at coil | 14 | 7 | 9 | 8 |
| Superheat at compressor | 17 | 20 | 16 | 10 |

NOTE

Subcooling and superheat readings are reliable when the conditioned space is at comfortable conditions.

OPERATION & MAINTENANCE (continued)

PREVENTIVE MAINTENANCE

WARNING

FIRE OR EXPLOSION HAZARD

Explosion risk, recover refrigerant only in a cylinder designed and intended for this purpose

- Do not use a damaged cylinder
- Do not apply flame or excessive heat to a refrigerant cylinder
- Do not fill a refrigerant cylinder to more than 80% of its capacity
- Do not use a refrigerant cylinder for anything other than its designed and intended purpose
- Do not use an expired refrigerant cylinder
- Use recovery equipment designed to handle the refrigerant being recovered
- Earth-ground refrigerant cylinders before using

WARNING

Failure to follow this warning could result in personal injury or death. Recover all refrigerant before attempting a sealed air conditioning system repair. Recover all refrigerant before final unit disposal. Use all service ports and position all refrigerant flow-control devices open, including expansion valves and solenoid valves.

WARNING

HIGH VOLTAGE!

Disconnect all power before servicing. Failure to do so may result in property damage, personal injury, or death.

CAUTION

Compressors and sealed system tubing components may be extremely hot!

CAUTION

Do not use compressors to evacuate the air conditioning system. A vacuum may cause internal electrical arcing resulting in a damaged or failed compressor.

WARNING

Do not exceed the maximum operating pressure listed on the unit rating plate.

IMPORTANT

It is illegal to discharge refrigerant into the atmosphere. Use proper reclaiming methods and equipment when installing or servicing this unit. Service should be performed by a QUALIFIED service agency. A sealed refrigerant system normally requires no maintenance since it is a closed, self-contained system.

CAUTION

Wear all appropriate personal protection equipment when servicing or maintaining this unit. Personal injury can result from sharp metal edges, moving parts, and hot or cold surfaces.

WARNING

FIRE OR EXPLOSION HAZARD

Failure to following this warning could result in personal injury, death and/or property damage. Do not use flames or any potential ignition sources to leak check R-545B refrigerant tubing or components.

WARNING

**FIRE OR EXPLOSION HAZARD
ELECTRIC SHOCK HAZARD**

Failure to follow safety warnings exactly could result in property damage, dangerous operation, serious injury, or death. Improper servicing could result in dangerous operation, serious injury, death, or property damage.

- Before servicing, disconnect all electrical power to the unit.
 - When servicing controls, label all wires prior to disconnecting. Reconnect wires correctly. Verify proper operation after servicing.

WARNING

Components rotate at high speeds when the unit is in operation. Do not touch any rotating component with any object. Damage to the equipment and personal injury can occur.

To ensure maximum performance and service life of equipment, a formal schedule of regular preventative maintenance must be established and adhered to.

Failure to do establish and perform preventative maintenance program can void the manufactures warranty.

OPERATION & MAINTENANCE (continued)

PREVENTIVE MAINTENANCE

To achieve maximum performance and service life of equipment, a formal schedule of regular maintenance should be established and adhered to.





If servicing or major repairs are required, the complete unit can be removed as follows:

1. Disconnect the electrical power circuit supplying the unit.
2. Remove line and low voltage wiring from unit,
3. Remove rear access panel.
4. Remove supply duct from top of unit.
5. Slide unit back out of sleeve.
6. Unit may be removed from closet.

To reinstall unit, use the installation procedure outlined above.

FAN

The fan should be inspected and cleaned annually in conjunction with maintenance of the motor and bearings. It is important to keep the fan section and motor clean and free from obstruction to prevent imbalance, vibration, and improper operation.

| | | |
|----------------------------------------------------------------------------------------------------------------------------------------------------------------------------------------------------------------------------------|------------------------------|-------------------------------------------------------------------------------------|
|  | WARNING |  |
|  | ELECTRIC SHOCK HAZARD |  |
| <p>Check motor connections to ensure they are secure and in accordance with the unit wiring diagram. ECM motors have line voltage power applied at all times.</p> <p>MAKE SURE POWER IS DISCONNECTED BEFORE SERVICING</p> | | |

FILTER

The air filter and ERV filters should be cleaned or replaced every 30 days or more frequently if severe operating conditions exist. Always replace the filter with the same type and size as originally furnished.

ERV CORE

The Energy Recovery plate heat exchanger (CORE), should be inspected at least twice (2) times a year. The CORE should be removed and cleaned as needed at least once (1) per year. The CORE can be cleaned with light air pressure or with a mild detergent and water solution. Be sure that the CORE is completely dry before reinserting it back into the ERV.

ERV INSULATION

The ERV interior should be inspected with the CORE (2 times a year). Check and clean the cabinet interior of all dirt and debris.

COIL

Clean all heat transfer surfaces and remove all dirt, dust, and contaminants that potentially impairs air flow using industry accepted practices. Care should be taken not to bend coil fin material.

CONDENSATE DRAIN PAN AND PIPE

Check and clean all dirt and debris from pan. Ensure drain line is free flowing and unobstructed.

MAINTENANCE UPDATES

Contact First Co. Technical Support for maintenance updates.

UNIT PERFORMANCE

Record performance measurements of volts, amps and water temperature differences (both heating and cooling). A comparison of logged data with start-up and other annual data is useful as an indicator of general equipment condition.

UNIT LOCKOUT

Air or water problems could cause periodic lockouts. The lockout (shutdown) of the units is a normal protective result. Check for dirt in the water system, water flow rates, water temperatures, airflow rates (may be caused by dirty filter) and air temperatures.

LABORATORY TESTING

When the unit has less than 100 operational hours and the coils have not had sufficient time to be "seasoned", it is necessary to clean the coils with mild surfactant such as Calgon to remove the oils left by manufacturing processes.

OPERATION & MAINTENANCE (continued)

Compressor bearing products designed for A2L refrigerants may come equipped with a factory installed refrigerant leak detection system. If the sensor is faulty, or disconnected, the appliance will not properly function.

False ceilings or drop ceilings may be used as a return air plenum if a refrigerant detection system is provided in the appliance and any external connections are also provided with a sensor immediately below the return air plenum duct joint.

QUALIFICATION OF WORKERS

Service shall only be performed by qualified technicians, certified by national training organizations or manufacturers that are accredited to teach the relevant national competency standards that may be set in legislation. Competence to properly service the appliance should be documented by a certificate.

CHECKS TO THE WORK AREA

Prior to beginning work on the appliance, safety checks are necessary to ensure that the risk of ignition of released gasses is minimized. Work shall be undertaken under a controlled procedure so as to minimize the risk of a flammable gas or vapor being present while the work is being performed.

All maintenance staff and others working in the local area shall be instructed on the nature of work being carried out. Work in confined spaces shall be avoided.

CHECKING FOR PRESENCE OF REFRIGERANT

The area shall be checked with an appropriate refrigerant detector prior to and during work, to ensure the technician is aware of potentially toxic or flammable atmospheres. Ensure that the leak detection equipment being used is suitable for use with all applicable refrigerants, i.e. non-sparking, adequately sealed or intrinsically safe.

If any hot work is to be conducted on the refrigerating equipment or any associated parts, appropriate fire extinguishing equipment shall be available to hand. Have a dry powder or CO2 fire extinguisher adjacent to the charging area.

No person carrying out work in relation to a REFRIGERATING SYSTEM which involves exposing any such a pipe work shall use any sources of ignition in manner that it may lead to the risk of fire or explosion.

All possible ignition sources, including cigarette smoking, should be kept sufficiently far away from the site of installation, repairing, removing and disposal, during which refrigerant can possibly be released to the surrounding space. Prior to work taking place, the area around the equipment is to be surveyed to make sure that there are no flammable hazards or ignition risks. "NO SMOKING" signs shall be displayed.

VENTILATED AREA

Ensure that the area is in the open or that it is adequately ventilated before breaking into the system or conducting any hot work. A degree of ventilation shall continue during the period that the work is carried out. The ventilation should safely disperse any released refrigerant and preferably expel it externally into the atmosphere.

CHECKS TO THE REFREIGERATING EQUIPMENT

Where electrical components are being changed, they shall be fit for the purpose and to the correct specification. At all times the manufacturer's maintenance and service guidelines shall be followed. If in doubt, consult the manufacturer's technical department for assistance.

The following checks shall be applied to installations using FLAMMANLE REFRIGERANTS:

- The actual REFRIGERANT CHARGE is in accordance with the room size within which the refrigerant containing parts are installed;
- The ventilation machinery and outlets are operating adequately and are not obstructed;
- Marking to the equipment continues to be visible and legible. Markings and signs that are illegible shall be corrected;
- Refrigerating pipe or components are installed in a position where they are unlikely to be exposed to any substance which may corrode refrigerant containing components, unless the components are constructed of materials which are inherently resistant to being corroded or are suitably protected against being so corroded.

OPERATION & MAINTENANCE (continued)

CHECKS TO ELECTRICAL DEVICES AND SEALED

ELECTRICAL COMPONENTS

Repair and maintenance to electrical components shall include initial safety checks and component inspection procedures. If a fault exists that could compromise safety, then no electrical supply shall be connected to the circuit until it is satisfactorily dealt with. If the fault cannot be corrected immediately but it is necessary to continue operation, an adequate temporary solution shall be used. This shall be reported to the owner of the equipment so all parties are advised.

Initial Safety Checks shall include:

- That capacitors are discharged: this shall be done in a safe manner to avoid possibility of sparking;
- That no live electrical components and wiring are exposed while charging, recovering or purging the system;
- That there is continuity of earth bonding.

Sealed electrical components shall be replaced in the event of damage or malfunction.

CABLING

Check that cabling will not be subject to wear, corrosion, excessive pressure, vibration, sharp edges or any other adverse environmental effects. The check shall also take into account the effects of aging or continual vibration from sources such as compressors or fans.

DETECTION OF FLAMMABLE REFRIGERANTS

Under no circumstances shall potential sources of ignition be used in the searching for or detection of refrigerant leaks. A halide torch (or any other detector using a naked flame) shall not be used.

Electronic leak detectors may be used to detect refrigerant leaks but, in the case of FLAMMABLE REFRIGERANTS, the sensitivity may not be adequate, or may need re-calibration. (Detection equipment shall be calibrated in a refrigerant-free area.) Ensure that the detector is not a potential source of ignition and is suitable for the refrigerant used. Leak detection equipment shall be set at a percentage of the LFL of the refrigerant and shall be calibrated to the refrigerant employed, and the appropriate percentage of gas (25 % maximum) is confirmed.

Leak detection fluids (such as the bubble method or fluorescent method agents) are also suitable for use with most refrigerants but the use of detergents containing

chlorine shall be avoided as the chlorine may react with the refrigerant and corrode the copper pipe-work.

If a leak is suspected, all naked flames shall be removed/extinguished. If a leakage of refrigerant is found which requires brazing, all of the refrigerant shall be recovered from the system, or isolated (by means of shut off valves) in a part of the system remote from the leak.

REMOVAL AND EVACUATION OF FLAMMABLE REFRIGERANTS

When breaking into the refrigerant circuit to make repairs – or for any other purpose – conventional procedures shall be used. However, for FLAMMABLE REFRIGERANTS it is important that best practice is followed since flammability is a consideration. The following procedure shall be adhered to:

- Remove refrigerant charge following local and national regulations
- Purge the circuit with inert gas (optional for A2L);
- Evacuate (optional for A2L)
- If using flame to open circuit, continuously flush system with an inert gas
- Open the circuit by cutting or brazing.

The refrigerant charge shall be recovered into the correct recovery cylinders if venting is not allowed by local and national codes. For appliances containing flammable refrigerants, the system shall be purged with oxygen-free nitrogen to render the appliance safe for flammable refrigerants. This process might need to be repeated several times. Compressed air or oxygen shall not be used for purging refrigerant systems.

For appliances containing flammable refrigerants, refrigerant purging shall be achieved by breaking the vacuum in the system with oxygen-free nitrogen and continuing until the working pressure is achieved, then venting to the atmosphere, and finally pulling down to a vacuum (optional for A2L). This process shall be repeated until no refrigerant is within the system (optional for A2L). When the final oxygen-free nitrogen charge is used, the system shall be vented down to atmospheric pressure to enable work to take place. The outlet for the vacuum pump shall not be close to any potential ignition sources, and ventilation shall be available.

OPERATION & MAINTENANCE (continued)

CHARGING PROCEDURES

In addition to conventional charging procedures, the following requirements shall be followed.

- Ensure that contamination of different refrigerants does not occur when using charging equipment. Hoses or lines shall be as short as possible to minimize the amount of refrigerant contained in them.
- Cylinders shall be kept in an appropriate position according to the instructions.
- Ensure that the REFRIGERATING SYSTEM is earthed prior to charging the system with refrigerant.
- Label the system when charging is complete (if not already).
- Extreme care shall be taken not to overfill the REFRIGERATING SYSTEM.

Prior to recharging the system, it shall be pressure-tested with the appropriate purging gas. The system shall be leak-tested on completion of charging but prior to commissioning. A follow up leak test shall be carried out prior to leaving the site.

DECOMMISSIONING

Before carrying out this procedure, it is essential that the technician is completely familiar with the equipment and all its detail. It is recommended good practice that all refrigerants are recovered safely. Prior to the task being carried out, an oil and refrigerant sample shall be taken in case analysis is required prior to re-use of recovered refrigerant. It is essential that electrical power is available before the task is commenced.

- A. Become familiar with the equipment and its operation.
- B. Isolate system electrically.
- C. Before attempting the procedure, ensure that:
 - a. mechanical handling equipment is available, if required, for handling refrigerant cylinders;
 - b. all personal protective equipment is available and being used correctly;
 - c. the recovery process is supervised at all times by a competent person;
 - d. recovery equipment and cylinders conform to the appropriate standards.
- D. Pump down refrigerant system, if possible.
- E. If a vacuum is not possible, make a manifold so that refrigerant can be removed from various parts of the system.

- F. Make sure that cylinder is situated on the scales before recovery takes place.
- G. Start the recovery machine and operate in accordance with instructions.
- H. Do not overfill cylinders (no more than 80 % volume liquid charge).
- I. Do not exceed the maximum working pressure of the cylinder, even temporarily.
- J. When the cylinders have been filled correctly and the process completed, make sure that the cylinders and the equipment are removed from site promptly and all isolation valves on the equipment are closed off.
- K. Recovered refrigerant shall not be charged into another REFRIGERATING SYSTEM unless it has been cleaned and checked.

LABELING

Equipment shall be labelled stating that it has been decommissioned and emptied of refrigerant. The label shall be dated and signed. For appliances containing FLAMMABLE REFRIGERANTS, ensure that there are labels on the equipment stating that the equipment contains FLAMMABLE REFRIGERANT.

RECOVERY

When removing refrigerant from a system, either for servicing order commissioning, it is recommended good practice that all refrigerants are removed safely. When transferring refrigerant into cylinders, ensure that only appropriate refrigerant recovery cylinders are employed. Ensure that the correct number of cylinders for holding the total system charge is available. All cylinders to be used are designated for the recovered refrigerant and labelled for that refrigerant (i.e. special cylinders for the recovery of refrigerant). Cylinders shall be complete with pressure-relief valve and associated shut-off valves in good working order. Empty recovery cylinders are evacuated and, if possible, cooled before recovery occurs.

The recovery equipment shall be in good working order with a set of instructions concerning the equipment that is at hand and shall be suitable for the recovery of the flammable refrigerant. If in doubt, the manufacturer should be consulted. In addition, a set of calibrated weighing scales shall be available and in good working order. Hoses shall be complete with leak-free disconnect couplings and in good condition

OPERATION & MAINTENANCE (continued)

The recovered refrigerant shall be processed according to local Legislation in the correct recovery cylinder, and the relevant waste transfer note arranged. Do not mix refrigerants in recovery units and especially not in cylinders.

If compressors or compressor oils are to be removed, ensure that they have been evacuated to an acceptable level to make certain that flammable refrigerant does not remain within the lubricant. The compressor body shall not be heated by an open flame or other ignition sources to accelerate this process. When oil is drained from a system, it shall be carried out safely

REFRIGERANT DETECTION SENSOR (RDS) INFORMATION

Refer to the appliance IOM for information regarding the minimum conditioned room requirements, and instructions for the RDS operation, installation, and wiring. Any field installed wiring connected to the RDS must be at least 18AWG and have minimum insulation thickness of 1.58mm or be protected from damage.

The RDS is not intended for service or repair. In the event of a sensor failure, the mitigation mode will engage and the sensor shall be replaced by removing the sensor and replacing it with a new sensor.

DUCTING

If the appliance is connected via an air duct system to one or more rooms with A2L refrigerants is installed in a room with an area of less than the minimum as noted on the unit physical data table, or a minimum effective dispersal volume less than 18m³(636 ft³), the room shall be without continuously operating open flames (e.g. an operating gas appliance), or other potential ignition sources (such as an operating electric heater/ hot surface). A flame producing device may be installed in the same space if the device is provided with an effective flame arrest.

Auxiliary devices which may be a potential ignition source shall not be installed in the duct work. Potential ignition sources include hot surfaces with a temperature exceeding 430°C (806°F) and electric switching devices.

PIPING

Pipe-work including piping material, pipe routing, and installation shall include protection from physical damage in operation and service, and be in compliance with national and local codes and standards, such as AHRAE 15, ASHRAE 15.2, IAPMO uniform mechanical code, ICC International Mechanical Code, or CSA B52. All field joints shall be accessible for inspection prior to being covered or enclosed.

PERFORMANCE TABLES

| ERV EFFECTIVENESS TABLE | | | | | | | |
|-------------------------|-----|-------------------|-----------------|-----|-----------------|--------|-------|
| SUPPLY TEMPERATURE | | RELATIVE HUMIDITY | SUPPLY AIR FLOW | | RECOVERY | | |
| | | | | | SENSIBLE | LATENT | TOTAL |
| °C | °F | RH % | L/s | CFM | Effectiveness % | | |
| 25 | 77 | 80 | 47 | 100 | 62.4 | 41.9 | 54.7 |
| 0 | 32 | 80 | 23 | 50 | 70.7 | 53.6 | 65 |
| 0 | 32 | 80 | 37 | 80 | 65.4 | 46 | 59 |
| 0 | 32 | 80 | 56 | 120 | 59.7 | 38.5 | 52.7 |
| -25 | -13 | 80 | 47 | 100 | 65.4 | 41.9 | 56.2 |

Table 24 - ERV Effectiveness

| VENTILATION PERFORMANCE | | | | | |
|--------------------------|----------|-----------------|-----|------------------|-----|
| EXTERNAL STATIC PRESSURE | | SUPPLY AIR FLOW | | EXHAUST AIR FLOW | |
| Pa | in. W.C. | L/s | Pa | L/s | Pa |
| 25 | 0.1 | 60 | 127 | 60 | 127 |
| 50 | 0.2 | 56 | 119 | 56 | 119 |
| 75 | 0.3 | 55 | 117 | 55 | 117 |
| 100 | 0.4 | 52 | 110 | 52 | 110 |
| 125 | 0.5 | 49 | 104 | 49 | 104 |
| 150 | 0.6 | 47 | 100 | 47 | 100 |
| 175 | 0.7 | 46 | 97 | 46 | 97 |
| 200 | 0.8 | 41 | 87 | 41 | 87 |
| 225 | 0.9 | 37 | 78 | 37 | 78 |
| 250 | 1.0 | 34 | 72 | 34 | 72 |

Table 25 - Ventilation Performance

SUPPORT MATERIAL

ASHRAE 62.2 VENTILATION STANDARD TABLES

| ASHRAE 62.2 CFM Sizing Chart | | | | | |
|------------------------------|--------------------------|-----|-----|-----|-----|
| FLOOR AREA | NUMBER OF BEDROOMS / CFM | | | | |
| | 0-1 | 2-3 | 4-5 | 6-7 | >7 |
| < 1500 | 30 | 45 | 60 | 75 | 90 |
| 1501 – 3000 | 45 | 60 | 75 | 90 | 105 |
| 3001 – 4500 | 60 | 75 | 90 | 105 | 120 |
| 4501 – 6000 | 75 | 90 | 105 | 120 | 135 |
| 6001 – 7500 | 90 | 105 | 120 | 135 | 150 |
| > 7500 | 105 | 120 | 135 | 150 | 165 |

ANSI/ASHRAE STANDARD 62.2-2010 – Ventilation Air Requirements; values in cfm. The above chart outlines the minimum requirements for continuous ventilation.

Table 26 - ASHRAE 62.2 CFM Sizing Chart

| ROOM COUNT CALCULATION METHOD TABLE | | | | |
|-------------------------------------|-----------------|-----------------------|---|--------------|
| LIVING SPACE | NUMBER OF ROOMS | X CFM (or L/s) | = | CFM Required |
| Master Bedroom | | x 20 cfm (for 10 L/s) | = | |
| Basement | | x 20 cfm (for 10 L/s) | = | |
| Single Bedroom | | x 10 cfm (for 5 L/s) | = | |
| Living Room | | x 10 cfm (for 5 L/s) | = | |
| Dining Room | | x 10 cfm (for 5 L/s) | = | |
| Family Room | | x 10 cfm (for 5 L/s) | = | |
| Recreation Room | | x 10 cfm (for 5 L/s) | = | |
| Other | | x 10 cfm (for 5 L/s) | = | |
| Kitchen | | x 10 cfm (for 5 L/s) | = | |
| Bathroom | | x 10 cfm (for 5 L/s) | = | |
| Laundry Room | | x 10 cfm (for 5 L/s) | = | |
| Utility Room | | x 10 cfm (for 5 L/s) | = | |
| TOTAL VENTILATION REQUIREMENT | | | = | |

Table 27 - Room Count Calculation Method Table

STARTUP & PERFORMANCE CHECKLIST INSTRUCTIONS



CUSTOMER _____ STARTUP DATE _____ JOB # _____
 ADDRESS _____ SERVICING COMPANY _____
 _____ TECHNICIAN _____
 MODEL # _____ SERIAL # _____ PHONE # _____

INSTALLATION CHECK LIST

- Inspect the unit for transit damage and report any damage on the carrier's freight bill.
- Check model number to insure it matches the job requirements.
- Install field accessories and unit adapter panels as required. Follow accessory and unit installation manuals.
- Verify field wiring, including the wiring to any accessories.
- Check all multi-tap transformers, to insure they are set to the proper incoming voltage.
- Prior to energizing the unit, inspect all the electrical connections.
- Power the unit. Bump the motor contractor to check rotation. Three phase motors are synchronized at the factory. If the blower fans are running backwards, de-energize power to the unit, then swap two of the three incoming electrical lines to obtain proper phasing. Re-check.
- Perform all start up procedures outline in the installation manual shipped with the unit.
- Fill in the Start Up Information as outlined below and on the following page.
- Provide owner with information packet. Explain the thermostat and unit operation.

START UP INFORMATION SHEET

ELECTRICAL

Supply Voltage L1-L2 _____ Compressor Amps _____
 Running Voltage L1-L2 _____ Blower Amps _____
 Secondary Voltage _____ Condenser Fan Amps _____
 C (black) to G (green) Volts* _____
 C (black) to W (white) Volts* _____ *With thermostat calling.

AMPERAGE – ERV MOTORS

Intake Motor: Nominal HP _____
 Rated Amps _____
 Running Amps _____
 Exhaust Motor: Nominal HP _____
 Rated Amps _____
 Running Amps _____

AIRFLOW

Intake Design CFM _____ Exhaust Design CFM _____
 Pressure Drop _____ Pressure Drop _____
 Calculated CFM _____ Calculated CFM _____
 Amb db Temp _____ Amb db Temp _____
 Return Air db Temp* _____ Return Air db Temp* _____
 Tempered Air db Temp* _____ Tempered Air db Temp* _____
*Measure after 15 minutes of run time

TEMPERATURES

Outdoor Air Temperature _____ DB _____ WB _____
 Cooling Supply Air Temperature _____ DB _____ WB _____
 Return Air Temperature _____ DB _____ WB _____
 Heating Supply Air Temperature _____ DB _____ WB _____

DOCUMENT #: _____

FIGURE 43 - Startup & Performance Checklist (1 of 2)

STARTUP & PERFORMANCE CHECKLIST (continued)



UNIT OPERATION

HEATING MODE

- 1 INDOOR BLOWER AMPS _____
- 2 TEMPERATURE RISE
 - Supply Duct Temperature _____
 - Return Duct Temperature - _____
 - Temperature Rise = _____
- 3 TOTAL EXTERNAL STATIC
 - Supply Duct Temperature _____
 - Return Duct Temperature + _____
 - Temperature Rise = _____
- 4 CONDENSATE LINE
 - Leak Free

COOLING MODE

- 5 INDOOR BLOWER AMPS _____
- 6 TEMPERATURE DROP
 - Return Duct Temperature _____
 - Supply Duct Temperature - _____
 - Temperature Drop = _____
- 7 TOTAL EXTERNAL STATIC
 - Supply External Static _____
 - Return External Static + _____
 - Total External Static = _____
- 8 DRAIN LINE
 - Leak Free
- 9 THERMOSTAT
 - Adjusted & Programmed
 - Explained Operation to Owner

The warranty may be void unless the Startup & Performance Checklist is completed and returned to the warrantor. If the HVAC unit is not installed properly the warranty will be void as the manufacturer can't be held accountable for problems that stem from improper installation.

FIGURE 44 - Startup & Performance Checklist (2 of 2)

NOTES



P.O. Box 270969 Dallas, TX 75227
www.firstco.com or www.ae-air.com