

*First Co.*

# FRESH-PAK HW

*Hydronic Heating (EFW)*

Space Constrained Vertical Unit With Fully Integrated ERV

1.0 – 2.5 Tons

Up to 47,800 BTUH Hydronic Heat

11.7 SEER2

R-454B

**eco**series  
FRESH-PAK



---

# TABLE OF CONTENTS

NOMENCLATURE .....	3
PRODUCT OVERVIEW .....	4
WHAT IS ERV .....	7
ERV SENSOR.....	8
ERV FAN PERFORMANCE.....	9
REQUIRED ACCESSORIES.....	12
WALL SLEEVE ERV DUCTING .....	13-14
LOUVERS .....	15
CONTROLS.....	16
OPTIONAL ACCESSORIES .....	17
GENERAL ASSEMBLY AND MAJOR COMPONENTS .....	18-19
<b>(EFW) HYDRONIC HEAT</b>	
PHYSICAL DATA.....	20
UNIT DIMENSIONS 12K .....	21
UNIT DIMENSIONS 18-30K.....	22
HOT WATER OUTLETS 12K-30K .....	23
ELECTRICAL DATA & HW HEATING TABLE.....	24
COOLING PERFORMANCE.....	25

In keeping with its policy of continuous progress and product improvement, First Co. reserves the right to make changes without notice.

# NOMENCLATURE

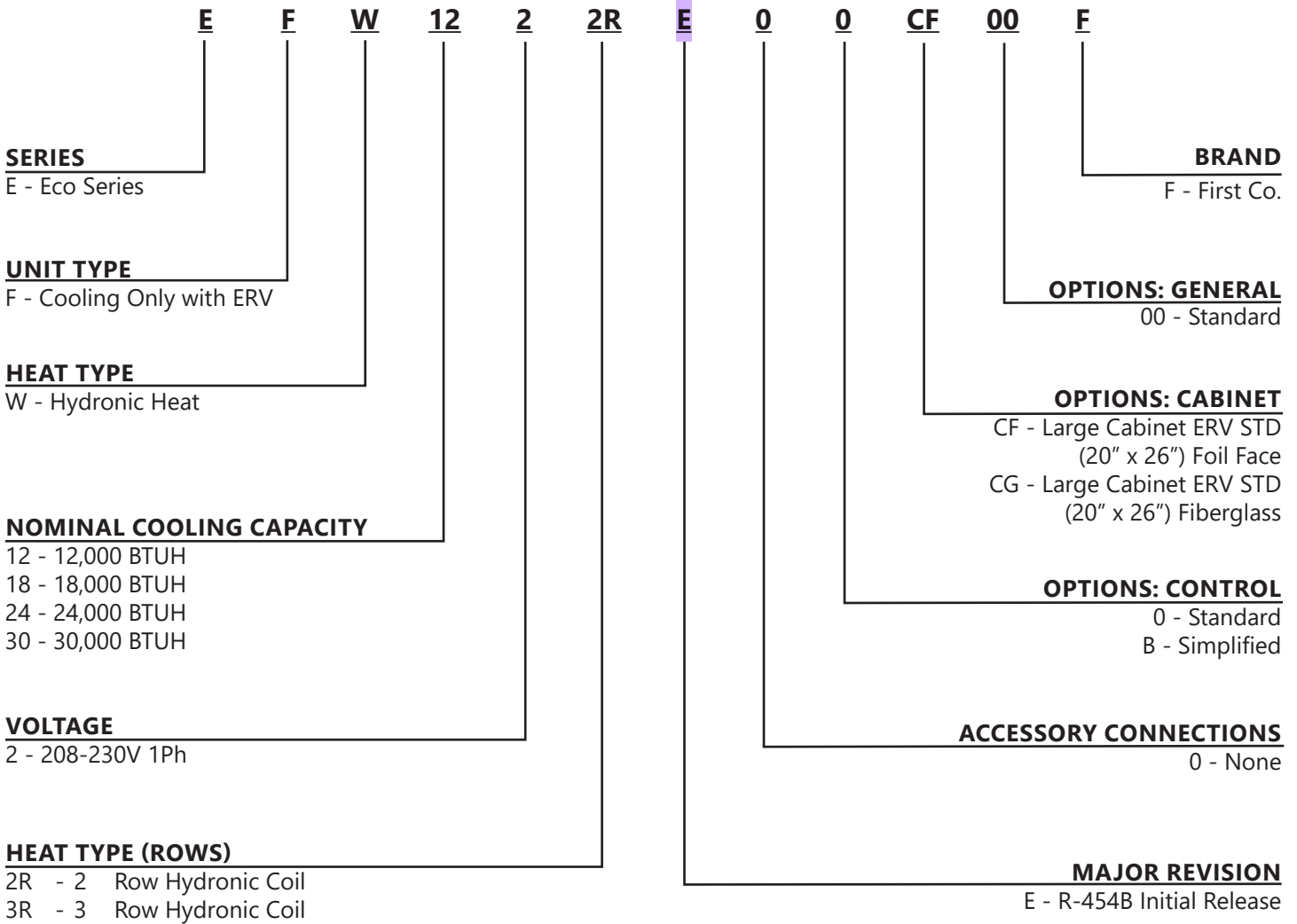

---

# FRESH-PAK HW

## SPACE CONSTRAINED VERTICAL UNIT

### PRODUCT DESCRIPTION

- Space constrained vertical unit with with integrated energy recovery ventilator (ERV)
- Pre-wired and pre-charged with R-454B refrigerant, capable of delivering conditioned air to multiple rooms
- Easily installs into a closet or mechanical room on an exterior wall, utilizing a minimal amount of floor space
- Controlled by a standard low voltage thermostat with ventilation capabilities

### APPLICATIONS

Hospitality, Apartments/Condominiums, Assisted Living/Memory Care, Student Housing, Senior Living and Modular/Prefabricated Buildings.

### STANDARD FEATURES

- Shipped ready for top supply and front return (with optional ducted return)
- Insulated compartment to improve cooling performance, reduce noise, and prevent sweating
- ECM indoor blower & outdoor fan motor to provide precise airflow selection and improve system efficiency
- High-efficiency scroll and rotary compressors with double isolated compressor mount to lower noise and vibration.
- Larger evaporator coil with low face velocity for improved cooling performance
- Drain pan with corrosion resistant coating to drain condensate in cooling and heating operations
- Thermal expansion valve (TXV) for cooling to optimize performance
- High pressure switch protection
- Filter brackets and disposable filter shipped with unit for field installation; no tool needed to replace filter
- Multi-function microprocessor control board
- Factory installed condensate float switch for overflow protection
- Refrigerant leak mitigation on units over 4lbs of charge

#### Warning:

**The incoming conductors of the service switch remain energized when the service switch is pulled out. Always disconnect power at the main source as well as the service switch before servicing. All lockout/tag out procedures must be followed.**

### SERVICEABILITY FEATURES

- Easy access for in-place service of most components
- All electrical components and control boards are serviceable from front of the unit

### WARRANTY

Five (5) year limited warranty on compressor and parts

### REQUIRED ACCESSORIES

- Single piece weight bearing wall sleeves with integrated ventilation air intake and exhaust ports for various wall thicknesses from 5" to 20"
- Flush type aluminum louver with finish and paint options
- Standard low voltage thermostat with ventilation capabilities
- WLAN service stick to program ERV control board (not required for Simplified Controls option)

# FRESH-PAK HW

## SPACE CONSTRAINED VERTICAL UNIT

### OPTIONAL ACCESSORIES

- Interior Access Panels - Louvered or Solid
- ERV Sensors - Humidity or Carbon Dioxide (field provided)
- ERV Exhaust Controls - Analog Egg Timer or Digital Timer Switch (field provided)

### STANDARD UNIT FEATURES

**Ductwork Connections** - Shipped ready for top supply duct connection and front non-ducted return with optional ducted return. If require by code, return air can be ducted to the unit.

**NOTE:** If ducted return is utilized, the filter will need to be relocated to a suitable location outside the cabinet for ease of service.

**Filter Rack** - Filter brackets and a disposable filter ship with each unit to be field installed over the evaporator coil.

**NOTE:** Do not use filters which will cause the total external static pressure, including ducts, louvers, registers, and filters to exceed 0.5 in. w.c.

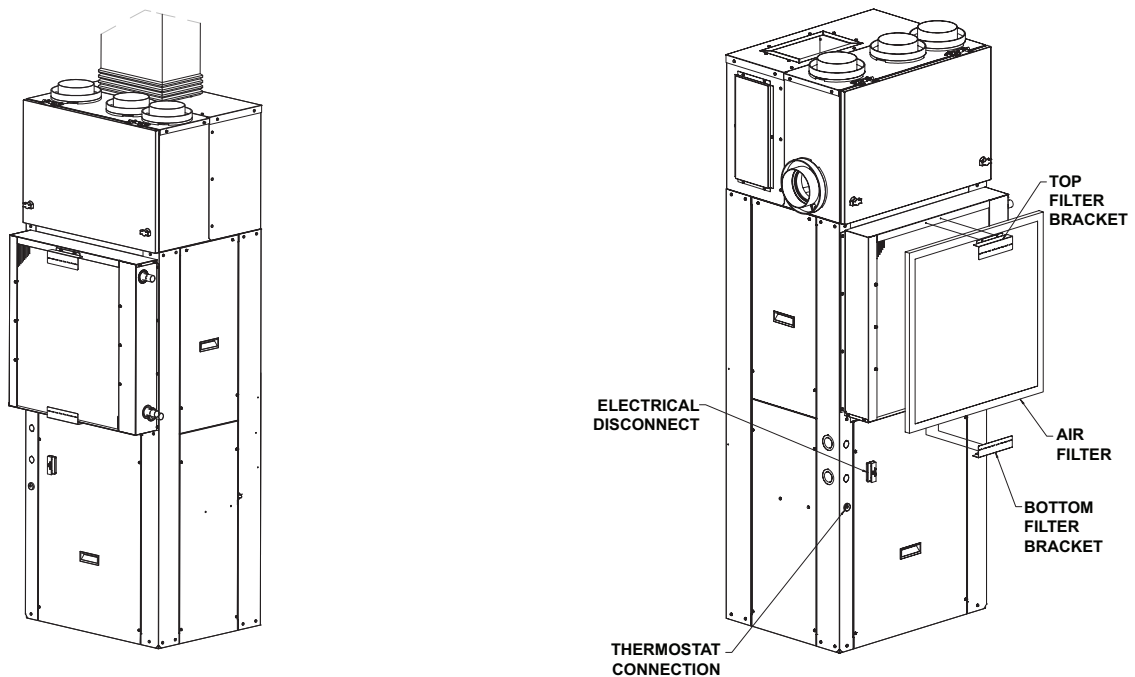

### MULTI-FUNCTION MICROPROCESSOR CONTROL BOARD

**Evaporator coil low temperature protection** – During the cooling mode, should the evaporator coil experience either a low temperature condition that could result in ice buildup on the coil or a reduced air flow situation, a temperature sensor attached to the coil will de-energize the unit. The sensor will re-energize the unit when the coil warms back up.

**Random restart** – When power is turned on after a power outage, a built-in random restart delay of 3-4 minutes prevents all compressors from restarting simultaneously.

**Compressor restart delay** – This delay ensures that system pressures are allowed to equalize before a compressor restart, which extends compressor life.

**Fan delay** – A fan delay allows the evaporator blower to continue running for up to 45 seconds after the thermostat is satisfied which maximizes cooling performance.

# FRESH-PAK HW

## SPACE CONSTRAINED VERTICAL UNIT

### SERVICE PULL OUT SWITCH

Provides a visible disconnecting means performing maintenance.

**WARNING:** This service switch does not de-energize the incoming power supply to the unit. ALWAYS turn off all power to the unit before servicing equipment. There may be more than one disconnect switch. All lockout/tag out procedures should be followed..

### CONDENSATE SYSTEM

#### Primary Condensate

Factory installed drain line connects the evaporator drain pan to a vertical pipe connection in the unit base pan. Evaporator condensate is delivered from the unit to a catch tray in the wall sleeve and exits the sleeve through the 3/4" male NPT fitting. This design allows the plumber to completely pipe the drain to a condensate riser during the rough-in stage, thus eliminating condensate connection problems usually encountered when trying to connect the HVAC drain to the riser after the HVAC unit is installed in the closet. This features also allows the unit to be removed for service without disconnecting the condensate piping. This configuration does not require any additional closet space to make the drain connection, as do some competitive products.

#### Secondary Condensate

If for any reason, the primary condensate riser becomes clogged, water will fill the catch tray and then be diverted through the wall sleeve to the exterior of the building, rather than be allowed to overflow into the closet or living area. Rain water entering the wall sleeve is automatically diverted to the condensate drain.

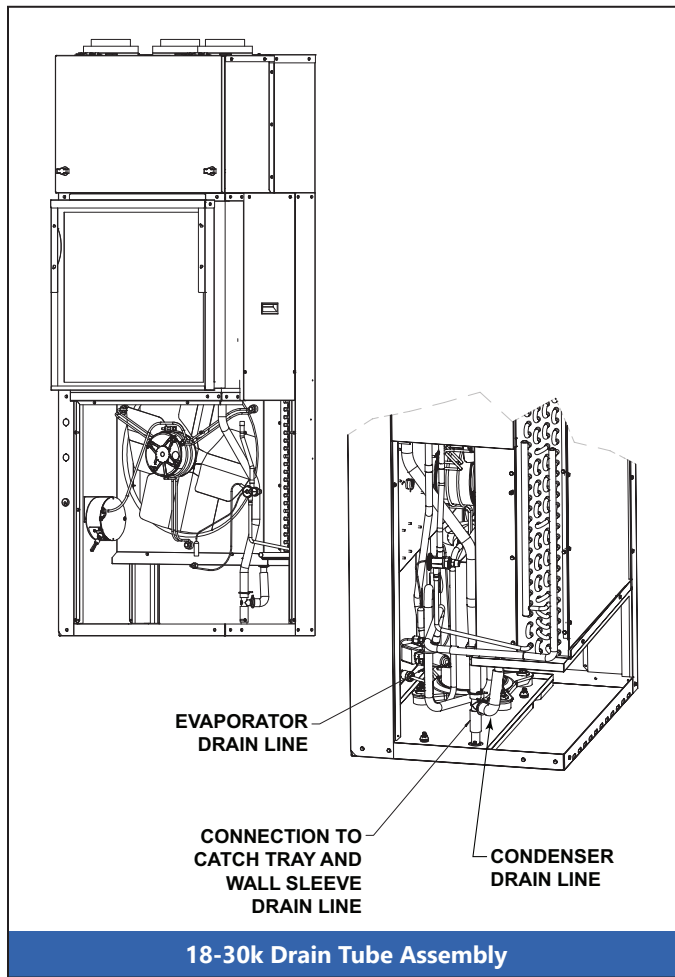
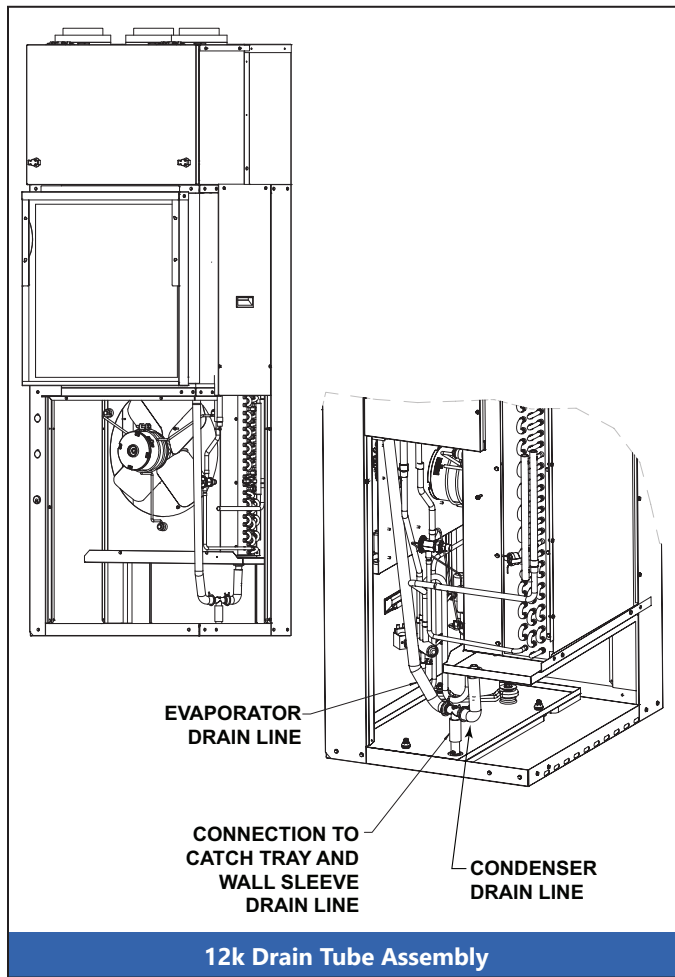

# FRESH-PAK HW

## SPACE CONSTRAINED VERTICAL UNIT

### WHAT IS ERV ?

**ENERGY RECOVERY VENTILATOR (ERV)** is a device that uses waste/stale air to precondition incoming outside/fresh air for ventilation.

**ERV** uses a polymer core to transfer temperature (sensible energy) and moisture (latent energy) from waste air to incoming ventilation air. It will cool the air in the warmer months and warm the air in the colder months.

Tighter construction requirements create less natural ventilation, the **ERV** offers the solution with balanced ventilation.

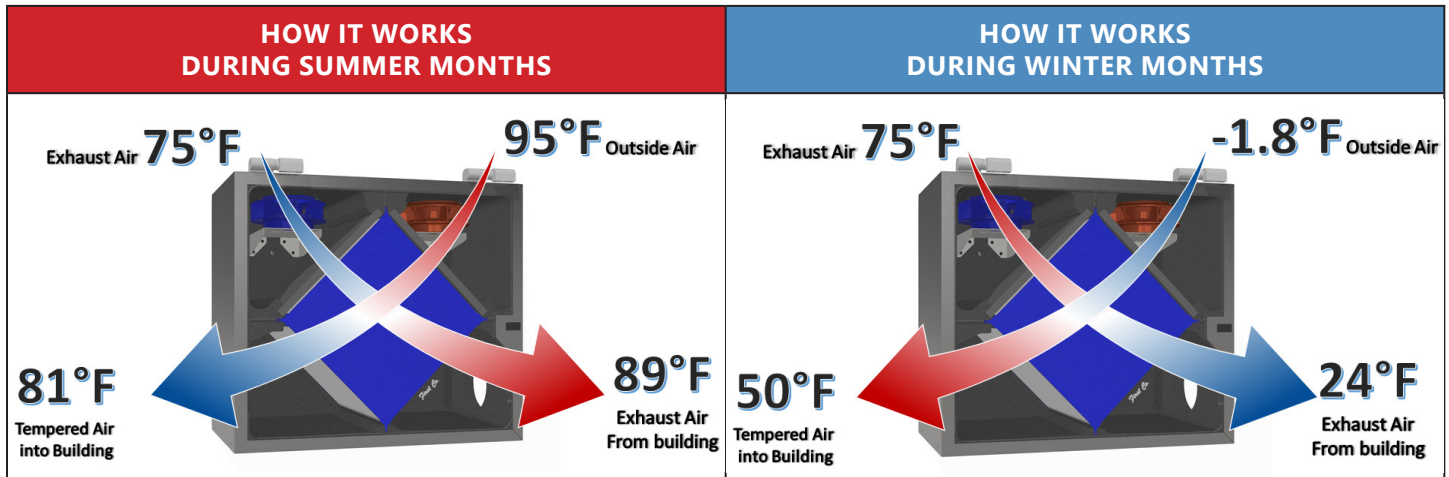

### INTEGRATED ENERGY RECOVERY VENTILATOR (ERV)

- **Core Enclosure:** Insulated one piece molded enclosure, made from mold/mildew resistant material. Completely sealed providing noise and air leakage reduction
- **Core:** Full enthalpy core made from polymer material that is removable for servicing & cleaning
- **Core Filters:** Filtration of ventilation air & return air with MERV 5 washable and disposable filters

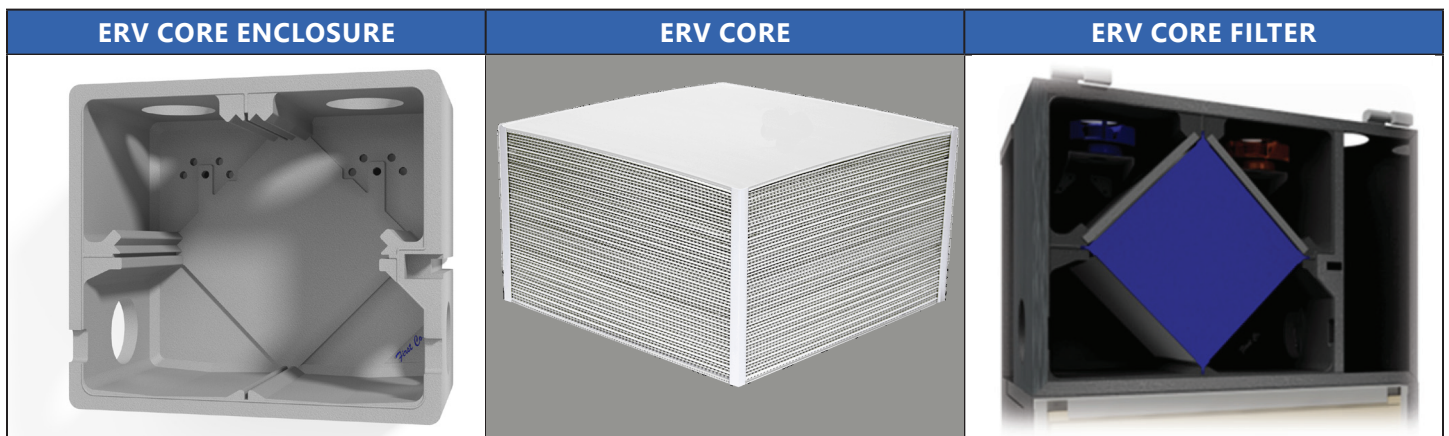

**DEFROST** – The ERV will sense when the exhaust drops below the set temperature and will activate the built-in multi-stage defrost mode. The first stage will reduce the fan speed to help warm up the core and prevent freezing. The second stage will, if optional, activate a 3rd party field installed electric preheater.

The ERV will cycle between defrost and normal operation until the temperature rises to the set point. It can be field configured so the supply fan can be switched off while the exhaust runs to warm up the core.





# FRESH-PAK HW

## SPACE CONSTRAINED VERTICAL UNIT

### ERV SENSORS

#### FIELD PROVIDED

- Humidity: Measures temperature and air humidity, signals ERV board to bring on ventilation
- Carbon Dioxide (CO2): Used for determining ventilation air supplied to maintain acceptable levels of CO2 in the space

BRAND	DESCRIPTION	PART NUMBER	IMAGE
Honeywell	Carbon Dioxide (CO2) Sensor Duct mounted no display	C7232	
Honeywell	Carbon Dioxide (CO2) Sensor wall mounted sensor with LED light display	C7233	
PCE	Humidity Sensor wall mounted 4 – 20 mA output	PCE-P18	
Honeywell	Humidistat wall mounted HumidiPRO Digital Humidity Control	H6062	

# FRESH-PAK HW

## SPACE CONSTRAINED VERTICAL UNIT

### ERV FAN PERFORMANCE

#### ERV FAN CURVE – AIR FLOW AT 60HZ

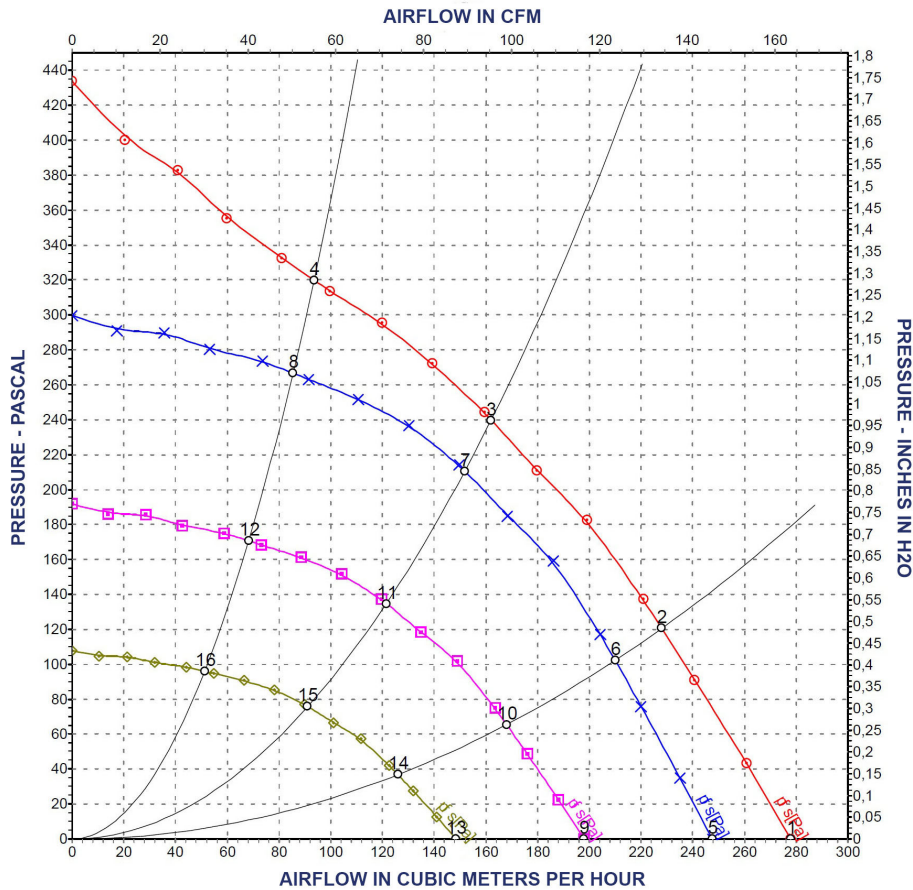

	VOLTAGE	FREQUENCY HZ	SPEED (REV/MIN)	POWER (WATTS)	CURRENT (AMPS)	AIRFLOW (M <sup>3</sup> /H)	PRESSURE (PA)	AIRFLOW (CFM)	PRESSURE (IN H <sub>2</sub> O)
1	230	60	3930	24	0.23	280	0	165	0.00
2	230	60	3800	26	0.26	230	120	136	0.48
3	230	60	3770	27	0.27	160	240	95	0.96
4	230	60	3835	26	0.25	95	320	56	1.28
5	230	60	3500	17	0.16	250	0	148	0.00
6	230	60	3500	20	0.2	210	102	124	0.41
7	230	60	3500	22	0.22	150	211	89	0.85
8	230	60	3500	19	0.19	85	267	51	1.07
9	230	60	2800	8.5	0.08	200	0	118	0.00
10	230	60	2800	10	0.1	170	66	101	0.26
11	230	60	2800	11	0.11	120	135	71	0.54
12	230	60	2800	9.9	0.1	70	171	42	0.69
13	230	60	2100	3.6	0.04	150	0	89	0.00
14	230	60	2100	4.4	0.04	125	37	74	0.15
15	230	60	2100	4.8	0.05	90	76	53	0.31
16	230	60	2100	4.2	0.04	50	96	30	0.39

# FRESH-PAK HW

## SPACE CONSTRAINED VERTICAL UNIT

### ERV FAN PERFORMANCE SUMMER

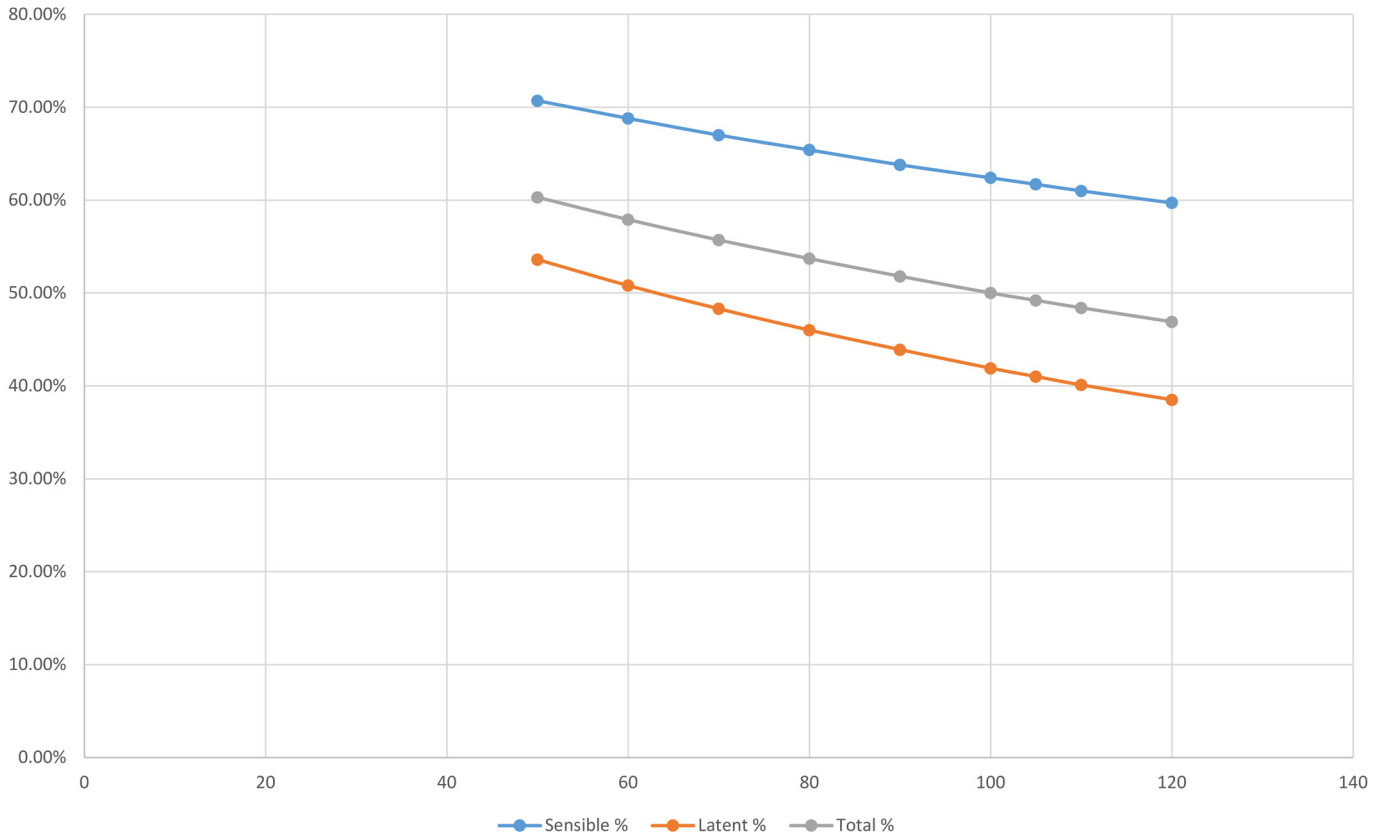

OUTDOOR		RETURN	
db	rh	db	rh
95	46.5%	75	51.17%



CFM	SENSIBLE %	LATENT %	TOTAL %
50	70.70%	53.60%	60.30%
60	68.80%	50.80%	57.90%
70	67.00%	48.30%	55.70%
80	65.40%	46.00%	53.70%
90	63.80%	43.90%	51.80%
100	62.40%	41.90%	50.00%
105	61.70%	41.00%	49.20%
110	61.00%	40.10%	48.40%
120	59.70%	38.50%	46.90%

# FRESH-PAK HW

## SPACE CONSTRAINED VERTICAL UNIT

### ERV FAN PERFORMANCE WINTER

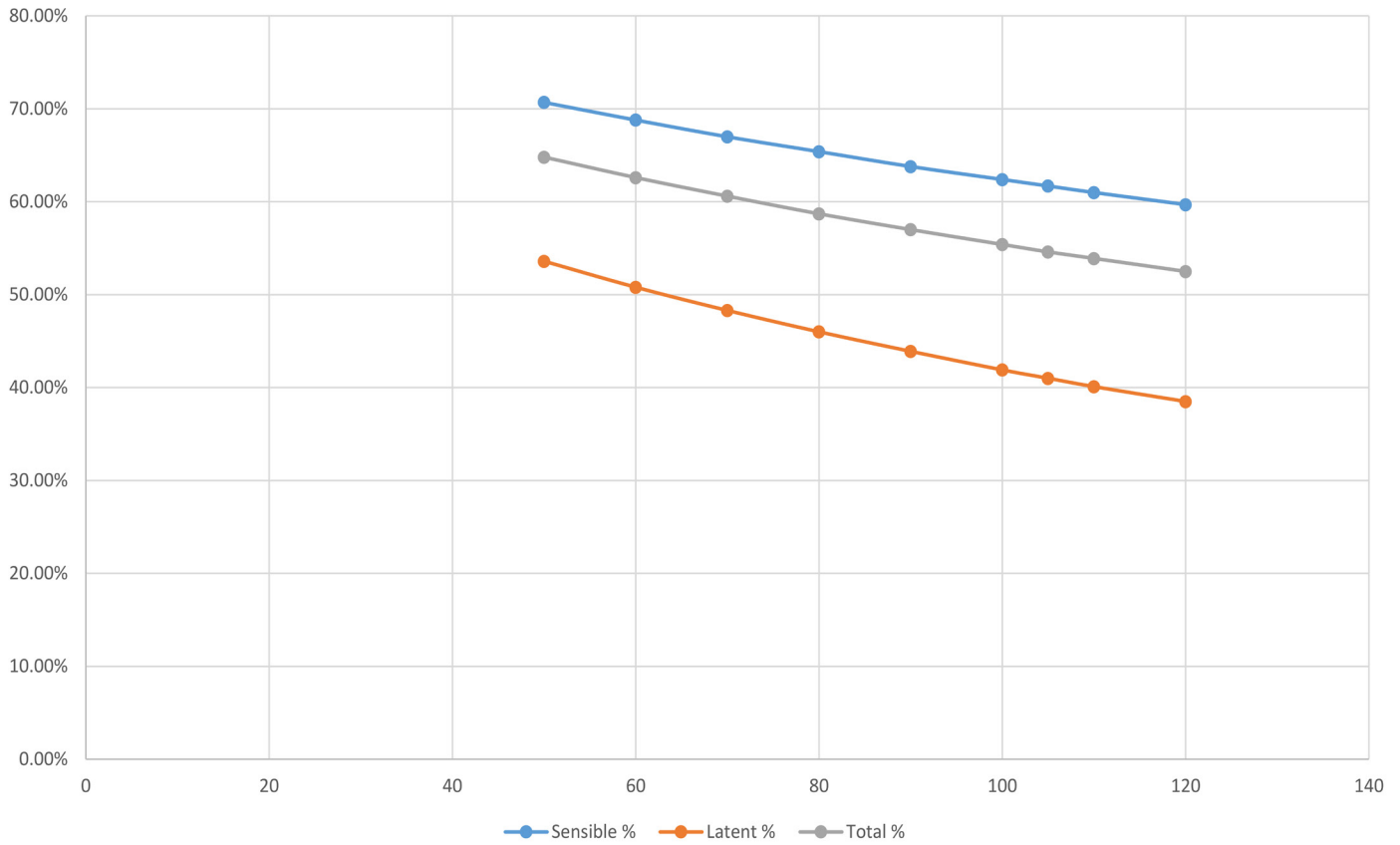

OUTDOOR		RETURN	
db	rh	db	rh
35	81.69%	70	47.88%



CFM	SENSIBLE %	LATENT %	TOTAL %
50	70.70%	53.60%	64.80%
60	68.80%	50.80%	62.60%
70	67.00%	48.30%	60.60%
80	65.40%	46.00%	58.70%
90	63.80%	43.90%	57.00%
100	62.40%	41.90%	55.40%
105	61.70%	41.00%	54.60%
110	61.00%	40.10%	53.90%
120	59.70%	38.50%	52.50%

# FRESH-PAK HW

## SPACE CONSTRAINED VERTICAL UNIT

### REQUIRED ACCESSORIES

**WALL SLEEVE, LOUVER AND THERMOSTAT ARE REQUIRED FOR EACH INSTALLATION**

#### WALL SLEEVES

- Fresh air intake and exhaust ports are built in to wall sleeve
- Provided for installation during rough-in or when ready the unit is slid into the wall sleeve and ductwork and electrical are connected.
- Weight bearing wall sleeve that supports the entire weight of the unit and provides a weather tight seal against wind and water infiltration
- Four wall sleeve depths are available to accommodate wall thickness from 5" to 20".
- Includes a weather guard to cover the sleeve opening and a debris guard to cover wall sleeve base and drain during construction

ACCESSORY	DESCRIPTION	DIMENSIONS (H X W X D)	PART #	A	B	C
<b>FRESH-PAK INTEGRATED TOP PORTS</b>	For 5" - 8" thick walls	43-1/4 x 26-1/2 x 37-1/4	999-21B-E	16-3/4"	20-15/16"	37-11/16"
	For 8" - 12" thick walls	43-1/4 x 26-1/2 x 41-1/4	999-22B-E	20-3/4"	20-15/16"	41-11/16"
	For 12" - 15" thick walls	43-1/4 x 26-1/2 x 44-1/4	999-23B-E	23-3/4"	20-15/16"	44-11/16"
	For 15" - 20" thick walls	43-1/4 x 26-1/2 x 50-1/4	999-24B-E	29-3/4"	20-15/16"	50-11/16"

All wall sleeves are shipped two (2) per carton, fully assembled.

**Wall sleeve, louver and thermostat are required for each installation.**

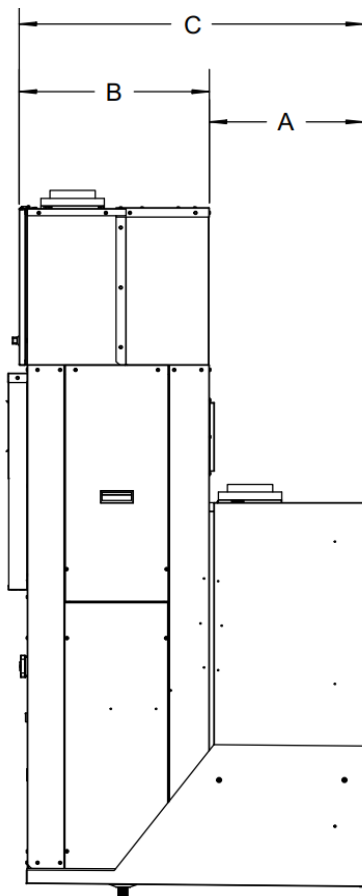

**WALL SLEEVE WITH TOP PORTS**

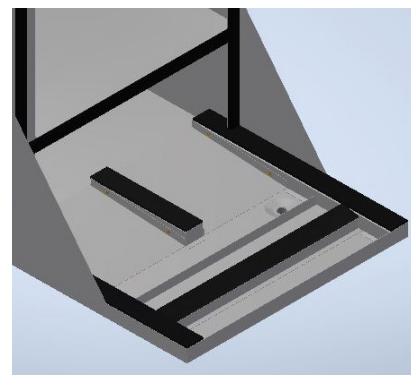
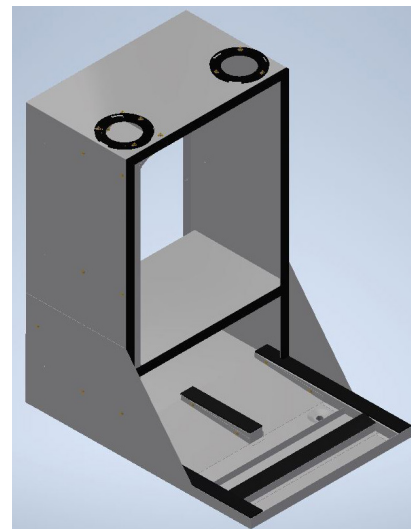

**WALL SLEEVE CONDENSATE DRAIN**

# FRESH-PAK HW

## SPACE CONSTRAINED VERTICAL UNIT

### WALL SLEEVE ERV DUCTING



Top Ducted Installation

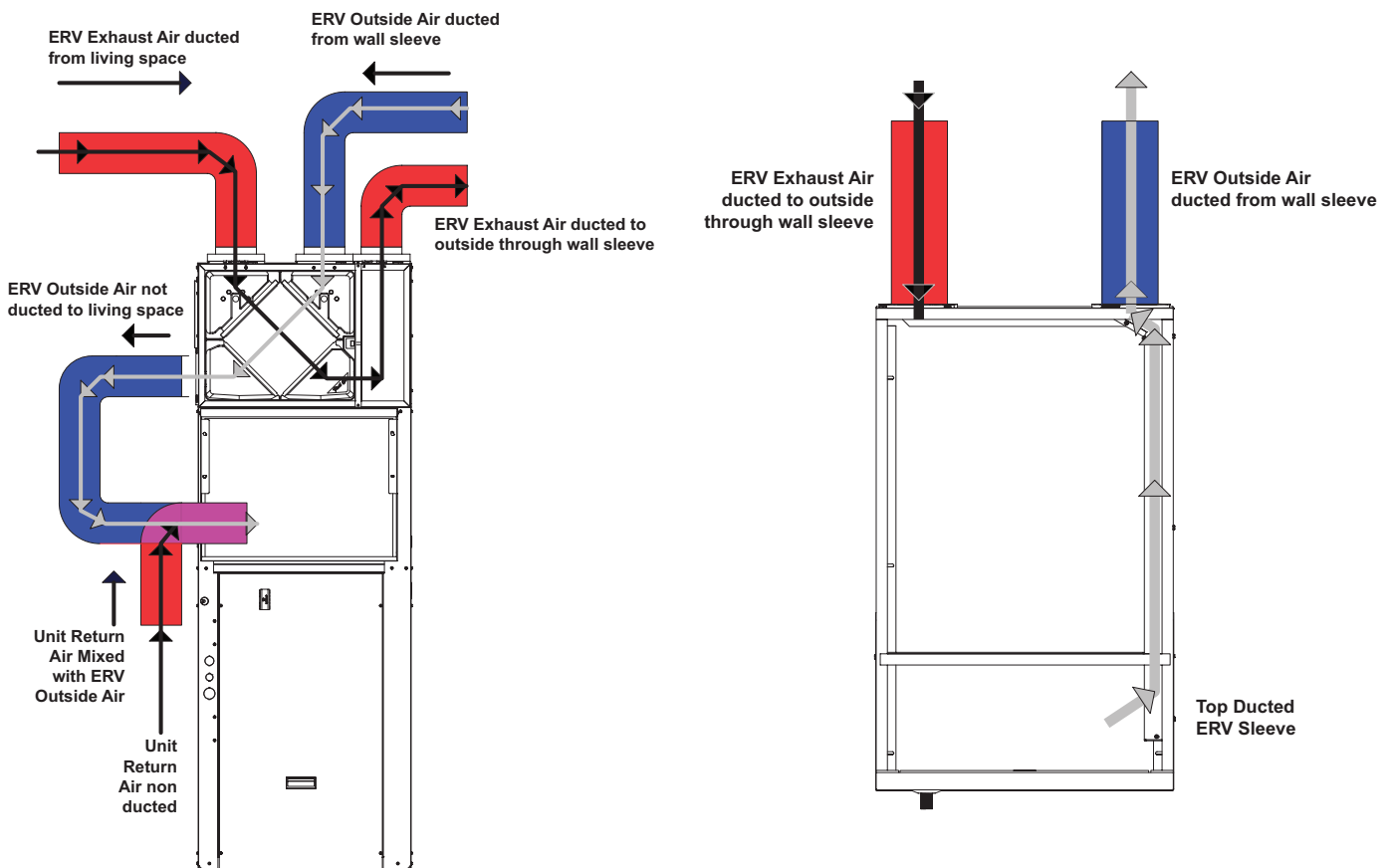

# FRESH-PAK HW

## SPACE CONSTRAINED VERTICAL UNIT

### OPTION 1

#### ELECTRIC PREHEAT

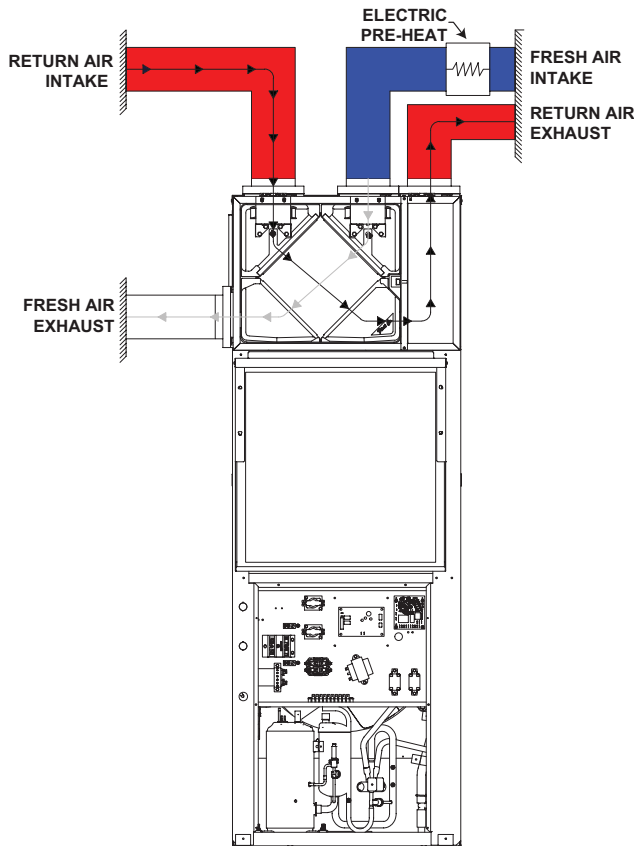

### OPTION 2

#### RECIRCULATION DAMPER

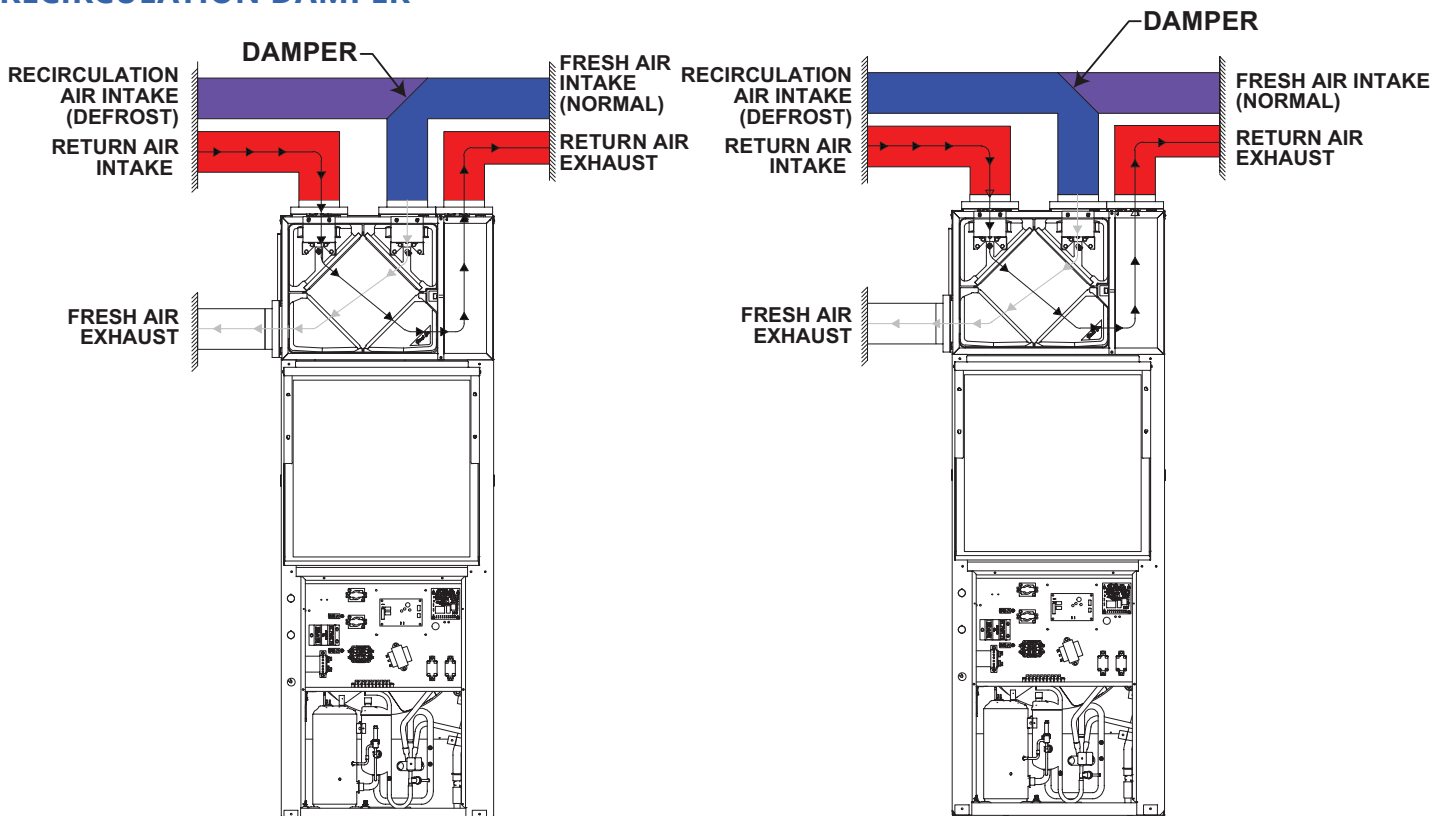

# FRESH-PAK HW

## SPACE CONSTRAINED VERTICAL UNIT

### LOUVERS

Extruded aluminum louver that attaches to the outside face of the wall sleeve. The blades of this unique louver recess into the wall sleeve for a neat, flush appearance.

Louver attachment screws are tightened from inside of the wall sleeve. Do not install the unit into the wall sleeve before installing the louver and tightening attachment screws.

DESCRIPTION	DIMENSIONS (H X W X D)	PART NUMBER
Field Painted	43-1/2 x 26-1/8	G8502PPA
Anodized Clear Coat	43-1/2 x 26-1/8	G8501A
Custom Painted	43-1/2 x 26-1/8	G8503S*

S\* indicates custom color, to be provided by customer. Minimum order quantity is 15 per color, if less than 15 set up fees will be applied

### STANDARD PAINT COLORS:

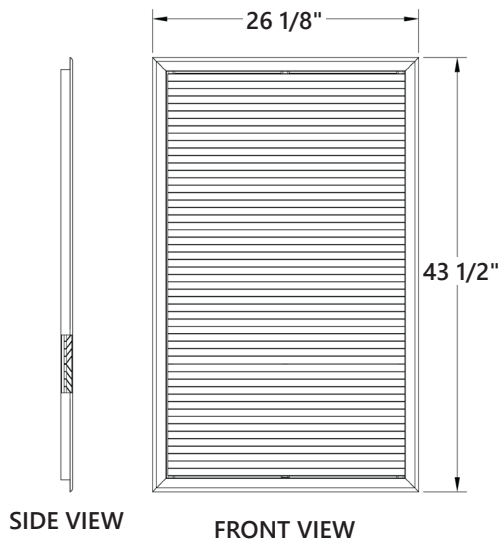

 SLATE BLUE (LF01)	 MEDIUM BRONZE (LF02)		
 LIGHT GRAY (LF04)	 CHARCOAL (LF05)		
 WESTERN TAN (LF07)	 ARCHITECTURAL BRONZE (LF08)		
 SANDSTONE (LF03)	 FOREST GREEN (LF10)	 SURREY BEIGE (LF11)	
 CLAY (LF15)	 BONE WHITE (LF06)	 BARN RED (LF13)	 BURGUNDY (LF14)
 VISTA GREEN (LF18)	 REGAL BLUE (LF09)	 ALMOND (LF16)	 COASTAL WHITE (LF17)
 CAMPUS GREEN (LF21)	 ROYAL BROWN (LF12)	 BLACK (LF19)	 GLOSS BLACK (LF20)

# FRESH-PAK HW

## SPACE CONSTRAINED VERTICAL UNIT

### CONTROLS

#### THERMOSTATS

Units are controlled by a standard low voltage thermostat. Thermostats with ventilation controls recommended for optimal ERV performance.

BRAND	DESCRIPTION	PART NUMBER	IMAGE
Honeywell	Programmable 7-day/5-2/5-1-1 3H/2C HP 2H/2C Conv. 24v Hardwired, C-wire only, Wi-Fi, aux heat lockout w/ventilation control	THX321WF3003W	

### WLAN SERVICE STICK

ERV Programming via WLAN\* service stick - Must purchase one stick per project. Required to program ERV board through the ABT GO app.

PART NUMBER	IMAGE
USB-300	

\*WLAN = wireless local area network

**NOTE:** Only required on Standard Controls package. Simplified Controls package can be programmed without a service stick.

# FRESH-PAK HW

## SPACE CONSTRAINED VERTICAL UNIT

### OPTIONAL ACCESSORIES

#### ACCESS PANELS

COMPONENT	DESCRIPTION	FRAME (A x C)	OPENING (B x D)	PART NUMBER	SHIPPING WEIGHT LBS.
RETURN AIR PANEL	LOUVERED	87 X 37	84 X 34	931-20	55
ACCESS PANEL	SOLID	87 X 37	84 X 34	931-16	55

**NOTE:**

No filter provided, requires unit mounted filter.

Both panels are insulated for sound reduction and have tamperproof screws.

Panels are shipped ten per carton.

A solid door or panel with a side wall return air grille will result in lower sound levels.



Return Air Panel



Access Panel

# FRESH-PAK HW

SPACE CONSTRAINED VERTICAL UNIT

## GENERAL ASSEMBLY AND MAJOR COMPONENTS

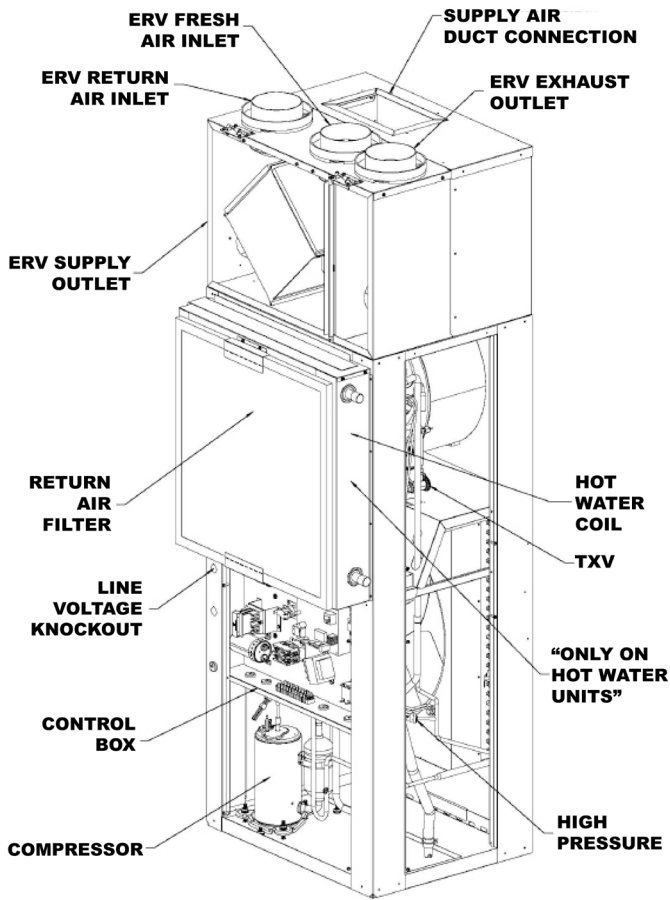

Major Components

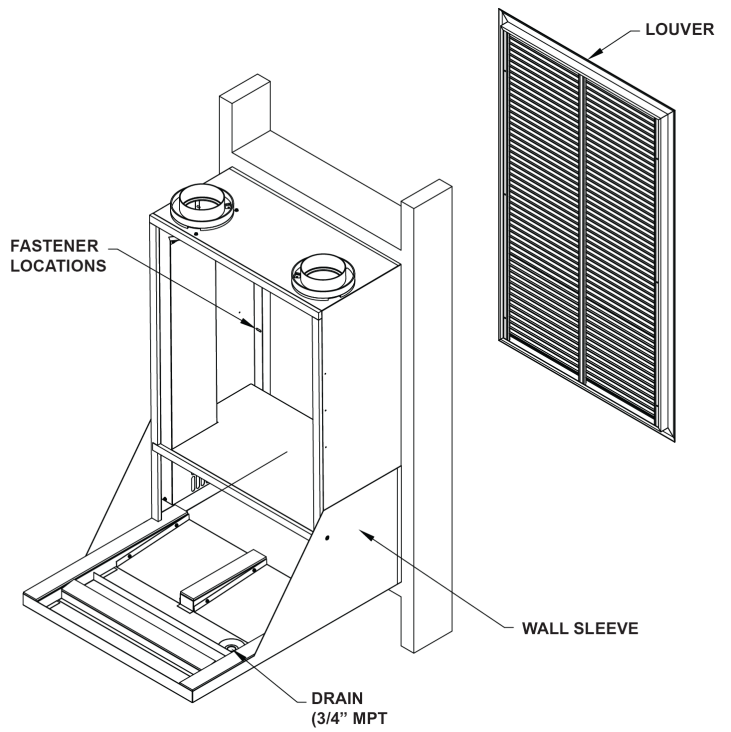

General assembly for wall sleeve and louver

# FRESH-PAK HW

## SPACE CONSTRAINED VERTICAL UNIT

### SIMPLIFIED CONTROL – MAJOR COMPONENTS

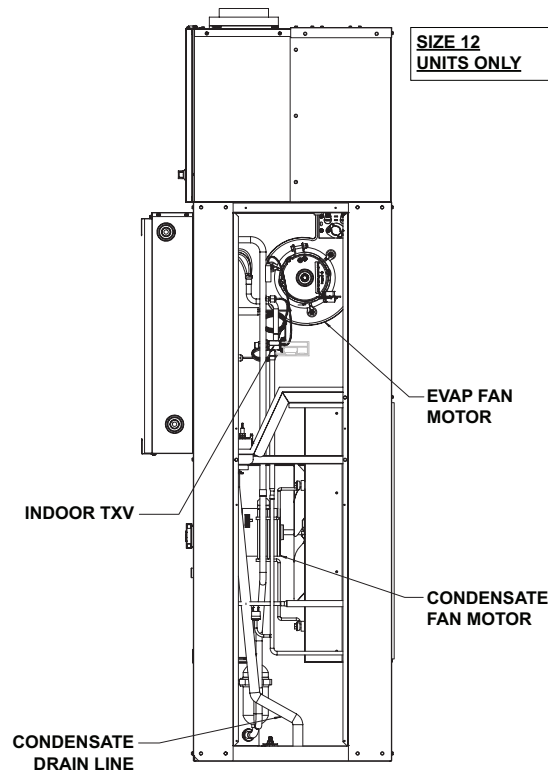
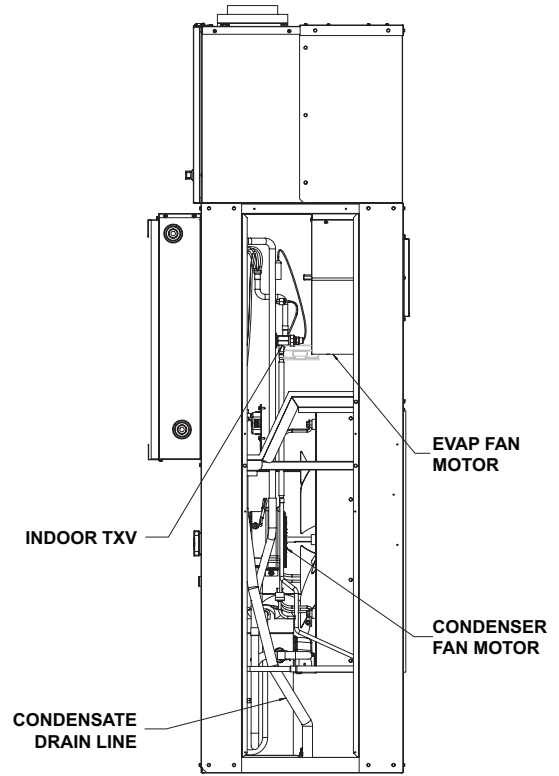
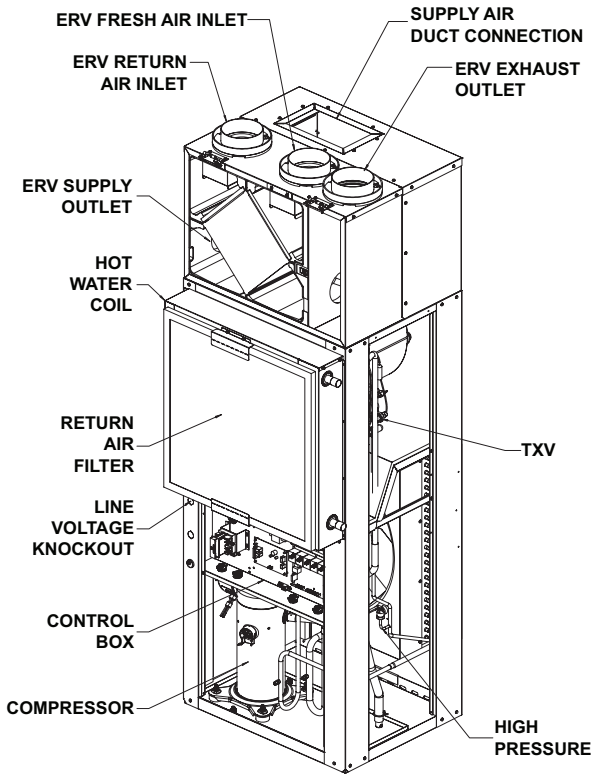

## HYDRONIC HEAT

PHYSICAL DATA					
454B FRESH PAK AC		EFW12	EFW18	EFW24	EFW30
Compressor (Quantity)		Rotary (1)		Scroll (1)	
Compressor FLA		4.6	7.6	9	12.8
Factory Charge (R454B)	lb	3.13	4.2	4.5	4.675
	kg	1.41	1.9	2.04	2.12
Minimum Room Area	m <sup>2</sup>	4.3	5.7	6.2	6.4
Minimum Room Area	Ft <sup>2</sup>	45.8	61.8	66.3	68.9
Minimum Air Flow	CFM	84	113	122	126
	M3/hr	143	193	207	215
ID MOTOR					
Motor (Quantity)		1	1	1	1
Fan Motor Type		ECM	ECM	ECM	ECM
Motor HP		1/4	1/3	1/3	1/2
Motor FLA		2.3	2.8	2.8	4.1
OD MOTOR					
Motor (Quantity)		1	1	1	1
Fan Motor Type		ECM	ECM	ECM	ECM
Motor HP		1/4	1/3	1/3	1/3
Motor FLA		2.3	2.8	2.8	2.8
ID BLOWER					
Blowers (Quantity)		1	1	1	1
Blower Wheel Size (D x W) in. [cm]		6 x 8	10 x 4	10 x 4	10 x 4
		[15.24 x 20.32]	[25.4 x 10.16]	[25.4 x 10.16]	[25.4 x 10.16]
EVAPORATOR COIL					
Dimensions (H x W) in. [cm]		24 x 16.25	24x22	24x22	24x22
		[61 x 41.275]	[61 x 55.88]	[61 x 55.88]	[61 x 55.88]
Face Area ft <sup>2</sup> [m <sup>2</sup> ]		3.53 [0.33]	3.53 [0.33]	3.53 [0.33]	3.53 [0.33]
Rows		3	4	4	4
OD COIL					
Dimensions (H x W) in. [cm]		26 x 16.5	26 x 22.5	26 x 22.5	26 x 22.5
		[66 x 42]	[66 x 57]	[66 x 57]	[66 x 57]
Face Area ft <sup>2</sup> [m <sup>2</sup> ]		3.0 [0.2772]	4.1 [0.3762]	4.1 [0.3762]	4.1 [0.3762]
MISCELLANEOUS					
Throwaway Filter Dim. in. [cm]		24 x 24	24 x 24	24 x 24	24 x 24
		[60.96 x 60.96]	[60.96 x 60.96]	[60.96 x 60.96]	[60.96 x 60.96]
Throwaway Filter Quantity		1	1	1	1
A2L MITIGATION		NO	YES	YES	YES
Operating Weight lb. [oz]		270 [122.5]	285 [129.3]	300 [136]	305 [138.3]
Packaged Weight lb. [oz]		290 [131.5]	305 [138.3]	320 [145.1]	325 [147.4]

## UNIT DIMENSIONS 12K

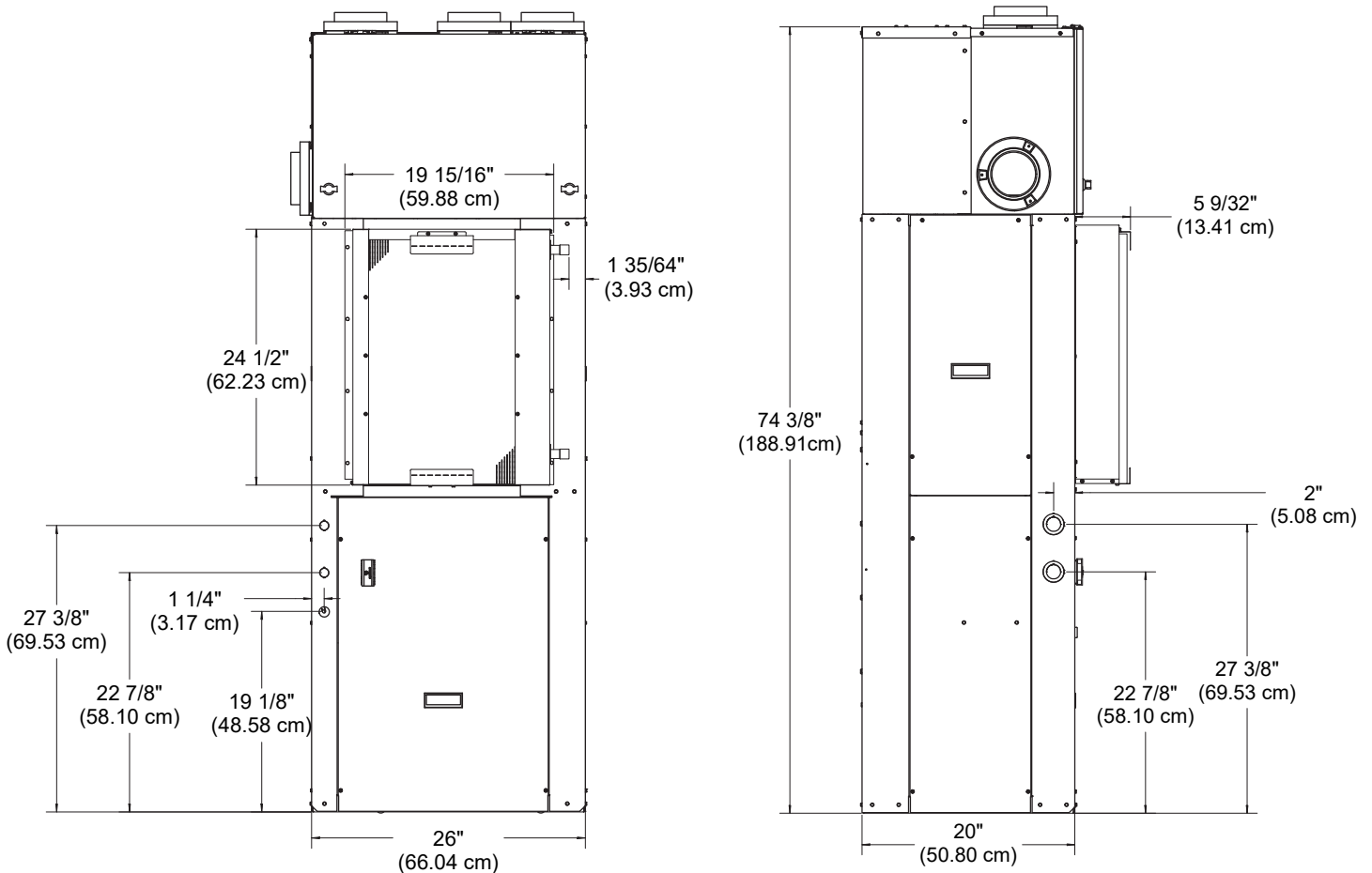
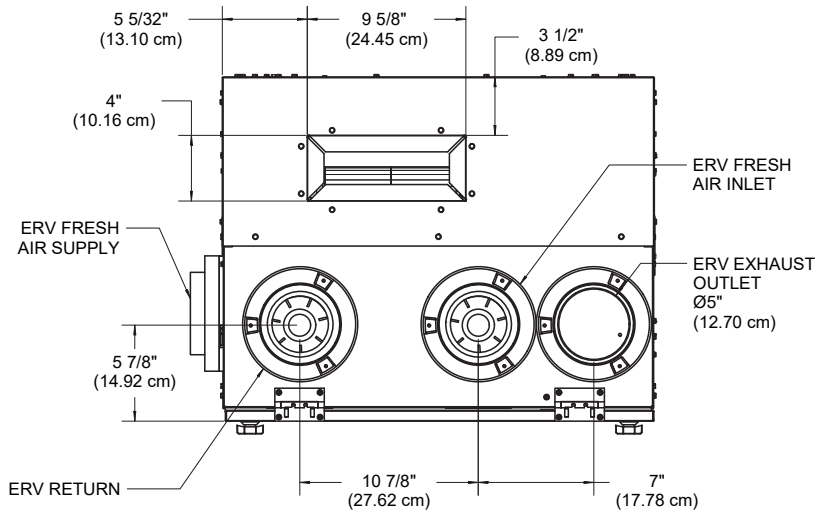

# FRESH-PAK HW

## SPACE CONSTRAINED VERTICAL UNIT

# EFW

## PHYSICAL DATA

### UNIT DIMENSIONS 18-30K

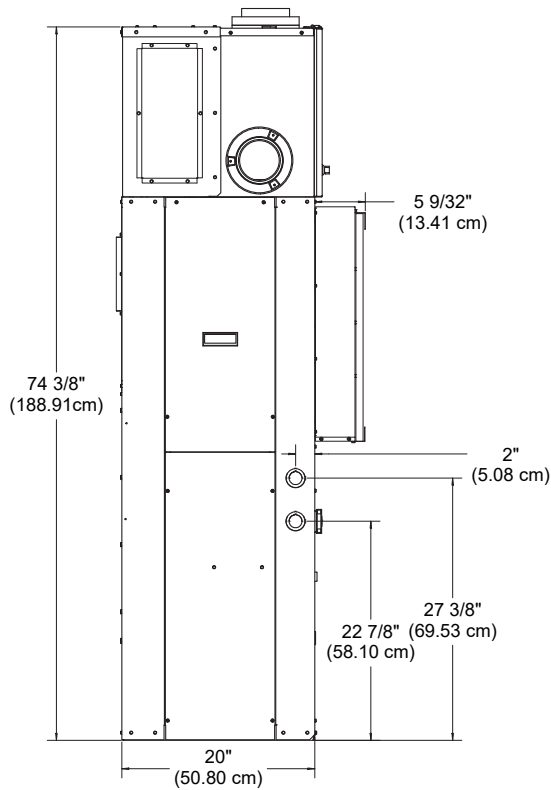
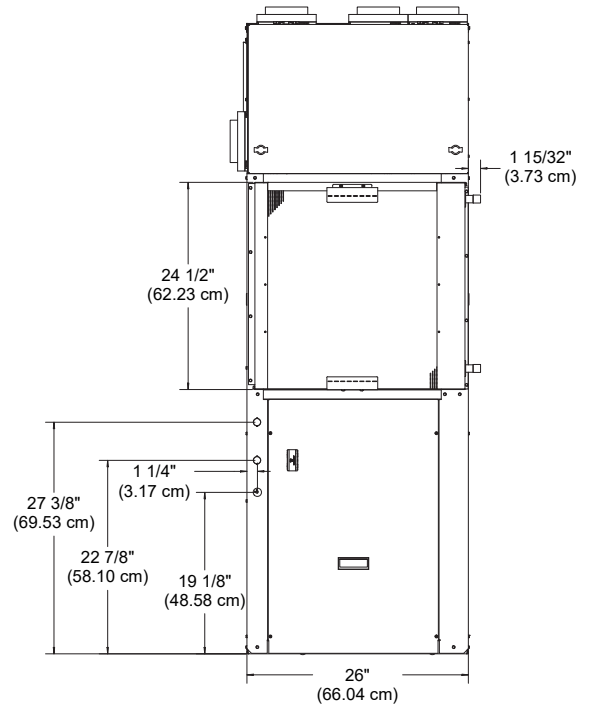
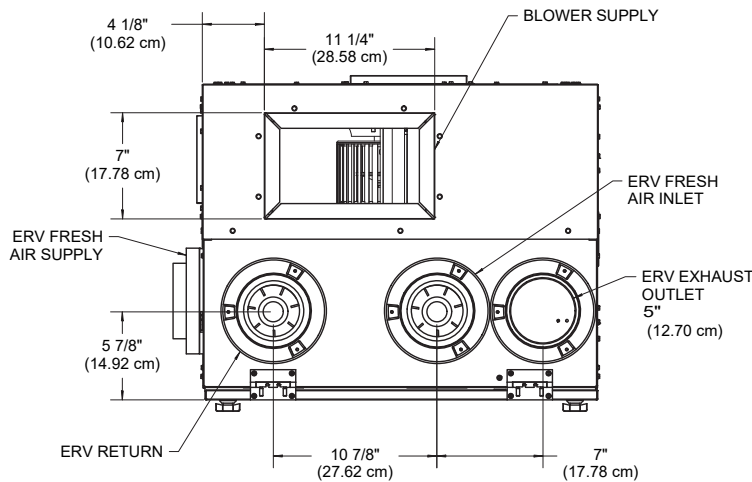

**18-30K HW 2R**

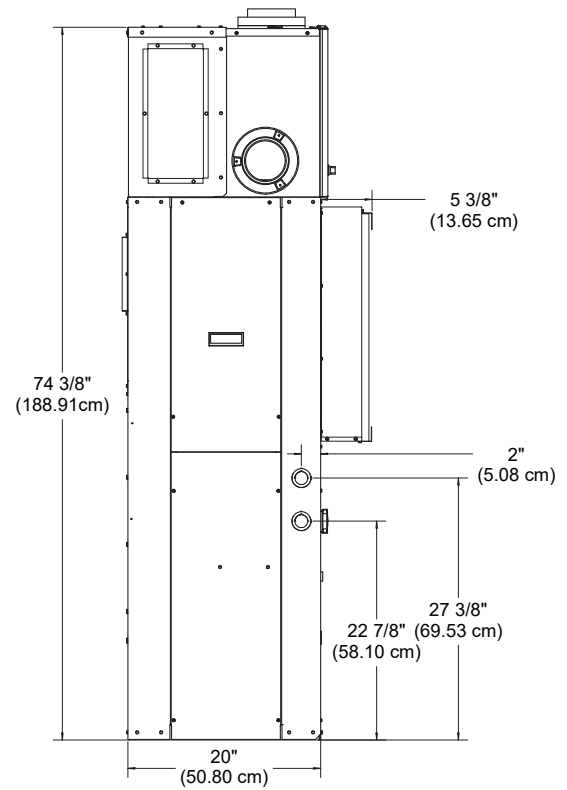

**18-30K HW 3R**

**HOT WATER OUTLETS 12K-30K**

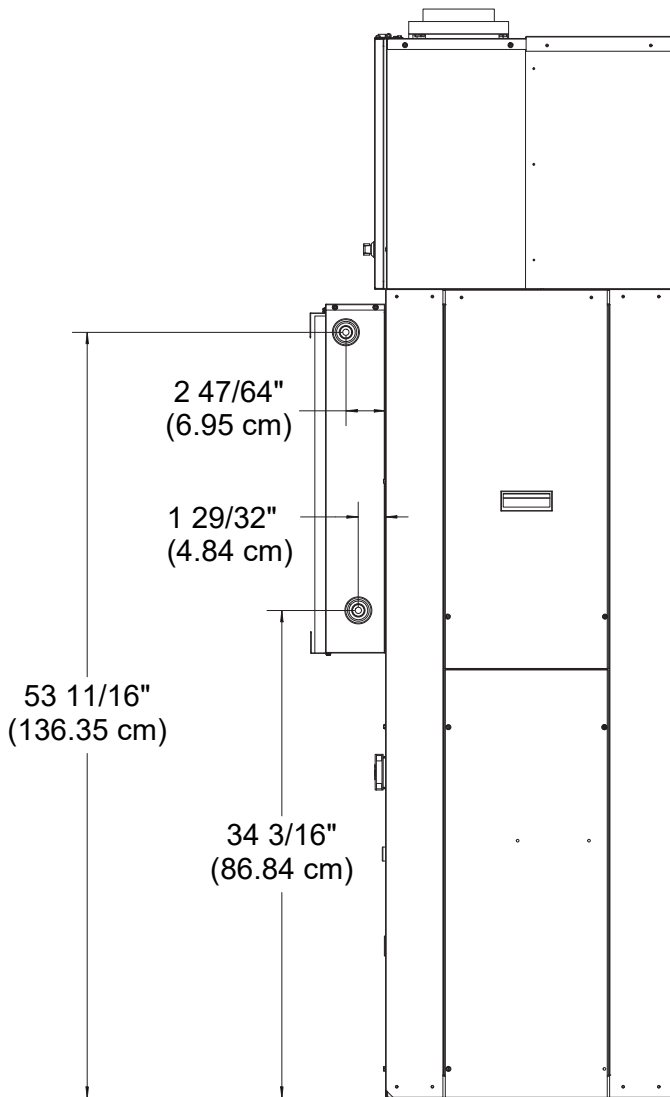

HW 2R

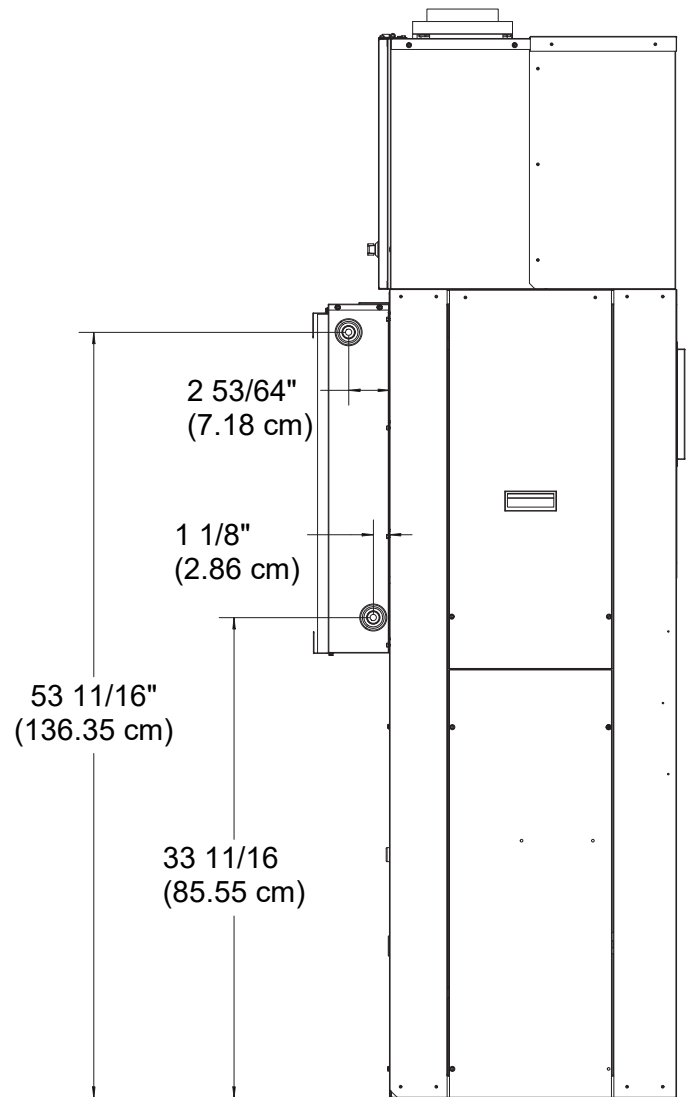

HW 3R

## ELECTRICAL DATA

COOLING WITH HOT WATER HEAT											
MODEL NUMBER	VOLTAGE	COMPRESSOR		OUTDOOR MOTOR		INDOOR MOTOR		MIN. CIRCUIT AMPACITY (MCA)		MAX. OVERCURRENT PROTECTION (MOP)	
		RLA	LRA	FLA	HP	FLA	HP	(L1-L2)		(L1-L2)	
								240V	208V	240V	208V
EFW1222RE0D*	208/230-1-60	4.6	25	2.3	1/4	2.3	1/4	12.0	12.0	15	15
EFW1822RE0D*	208/230-1-60	7.6	36	2.8	1/3	2.8	1/3	17.0	17.0	20	20
EFW1823RE0D*	208/230-1-60	7.6	36	2.8	1/3	2.8	1/3	17.0	17.0	20	20
EFW2422RE0D*	208/230-1-60	9	63	2.8	1/3	2.8	1/3	19.0	19.0	25	25
EFW2423RE0D*	208/230-1-60	9	63	2.8	1/3	2.8	1/3	19.0	19.0	25	25
EFW3022RE0D*	208/230-1-60	12.8	77	2.8	1/3	4.1	1/2	25.0	25.0	35	35
EFW3023RE0D*	208/230-1-60	12.8	77	2.8	1/3	4.1	1/2	25.0	25.0	35	35

**NOTE:**

Refer to the wiring diagrams in the EFW IOM for additional details  
 Wire size should be determined in accordance with National Electric Codes  
 Unit are rated for 208/230V, but MOP,MCA values are calculated at 208/240V

HOT WATER HEATING TABLE						
UNIT MODEL	AIRFLOW (CFM)	GPM	P.D. (Ft. Wtr.)	MBTUH @ ENTERING WATER TEMPERATURE		
				120.0	140.0	180.0
EFW1222R	400	1	0.3	10.6	15.0	24.2
		1.5	0.7	12.2	17.3	27.5
		2	1.2	13.2	18.6	29.5
EFW1822R	600	2	1.3	18.0	25.4	40.3
		2.5	2	19.1	26.9	42.7
		3	2.8	19.9	28.0	44.4
EFW1823R	600	2	1.2	20.8	29.3	46.4
		2.5	1.8	22.3	31.3	49.5
		3	2.5	23.3	32.7	51.7
EFW2422R	800	2	1.4	20.9	29.5	46.9
		2.5	2	22.5	31.7	50.3
		3	2.8	23.6	33.3	52.8
EFW2423R	800	2	1.2	24.3	34.2	54.1
		2.5	1.8	26.3	37.0	58.6
		3	2.5	27.8	39.2	62.0
EFW3022R	950	2	1.4	23.4	32.7	52.0
		2.5	2	25.2	35.5	56.4
		3	2.8	26.7	37.6	59.7
EFW3023R	950	2	1.2	26.8	37.8	59.9
		2.5	1.8	29.5	41.6	65.8
		3	2.5	31.5	44.4	70.3

## COOLING PERFORMANCE

EFW – EXTENDED COOLING PERFORMANCE																			
Model	Indoor Temp DB/WB	Outdoor Temperature°F																	
		65.0°F			75.0°F			85.0°F			95.0°F			105.0°F			115.0°F		
		B T U H	S/T	KW	B T U H	S/T	KW	B T U H	S/T	KW	B T U H	S/T	KW	B T U H	S/T	KW	B T U H	S/T	KW
EFW12	75/57	11850	1.00	0.76	11500	1.00	0.86	10700	1.00	0.98	10100	1.00	1.06	9650	1.00	1.20	9100	1.00	1.36
	75/63	12900	0.75	0.76	12250	0.76	0.86	11650	0.78	0.96	10900	0.79	1.04	10300	0.82	1.18	9650	0.84	1.36
	80/67	13800	0.72	0.76	13150	0.74	0.86	12500	0.76	0.96	11700	0.77	1.04	11000	0.79	1.18	10300	0.82	1.36
	85/72	14950	0.65	0.76	14250	0.67	0.84	13550	0.69	0.96	12700	0.70	1.04	11950	0.71	1.18	11200	0.74	1.36
EFW18	75/57	19000	1.00	1.32	18300	1.00	1.44	17150	1.00	1.58	15550	1.00	1.70	14800	1.00	1.88	14100	1.00	2.06
	75/63	20400	0.76	1.32	19400	0.77	1.44	18450	0.79	1.56	16300	0.84	1.70	15400	0.86	1.86	14600	0.90	2.06
	80/67	21700	0.73	1.32	20750	0.75	1.42	19700	0.76	1.56	17450	0.81	1.70	16450	0.83	1.86	15550	0.87	2.06
	85/72	23500	0.66	1.30	22450	0.68	1.42	21350	0.69	1.56	18950	0.74	1.70	17850	0.76	1.86	16800	0.79	2.06
EFW24	75/57	24450	1.00	1.76	23800	1.00	1.90	22300	1.00	2.08	15550	1.00	1.70	14800	1.00	1.88	14100	1.00	2.06
	75/63	26450	0.75	1.76	25300	0.77	1.92	24050	0.78	2.08	22700	0.80	2.34	21550	0.82	2.56	20300	0.84	2.80
	80/67	28250	0.73	1.76	26900	0.73	1.92	25650	0.75	2.10	24150	0.77	2.34	22900	0.79	2.56	21650	0.81	2.80
	85/72	30450	0.65	1.76	29100	0.67	1.92	27700	0.68	2.10	26150	0.70	2.34	24750	0.72	2.58	23450	0.75	2.82
EFW30	75/57	29100	1.00	2.26	28150	1.00	2.46	27400	1.00	2.68	25150	1.00	2.90	24250	1.00	3.16	23200	1.00	3.46
	75/63	31900	0.73	2.30	30600	0.74	2.50	29200	0.75	2.72	27150	0.77	2.94	25900	0.79	3.2	24750	0.82	3.50
	80/67	33950	0.70	2.34	32550	0.72	2.52	31200	0.73	2.74	28950	0.75	2.96	27800	0.78	3.24	26200	0.79	3.52
	85/72	36550	0.63	2.36	35050	0.65	2.56	33650	0.67	2.80	31350	0.69	3.02	29750	0.70	3.28	28300	0.72	3.58

Performance modeled at Rated Airflow, .3" in H<sub>2</sub>O ESP



*AMERICAN-MADE. FAMILY OWNED.*



FIRST CO.  
P.O. BOX 270969 - DALLAS, TEXAS 75227  
PH. (214) 388-5751 | FAX (214) 388-2255  
[WWW.FIRSTCO.COM](http://WWW.FIRSTCO.COM)

**MARCH 2026**