

First Co.

FIRST-PAK™

GAS



*Space Constrained Gas Unit
(FPGN9)*

1.0 - 2.5 Tons

Up to 55,000 BTU/Hr Heating

Up to 96% AFUE

11.7 SEER 2

R454B



AHRI CERTIFIED®
www.ahridirectory.org

Unitary Small AC
AHRI Standard 210/240
Certification applies only when the complete system
is listed with AHRI.

NOMENCLATURE

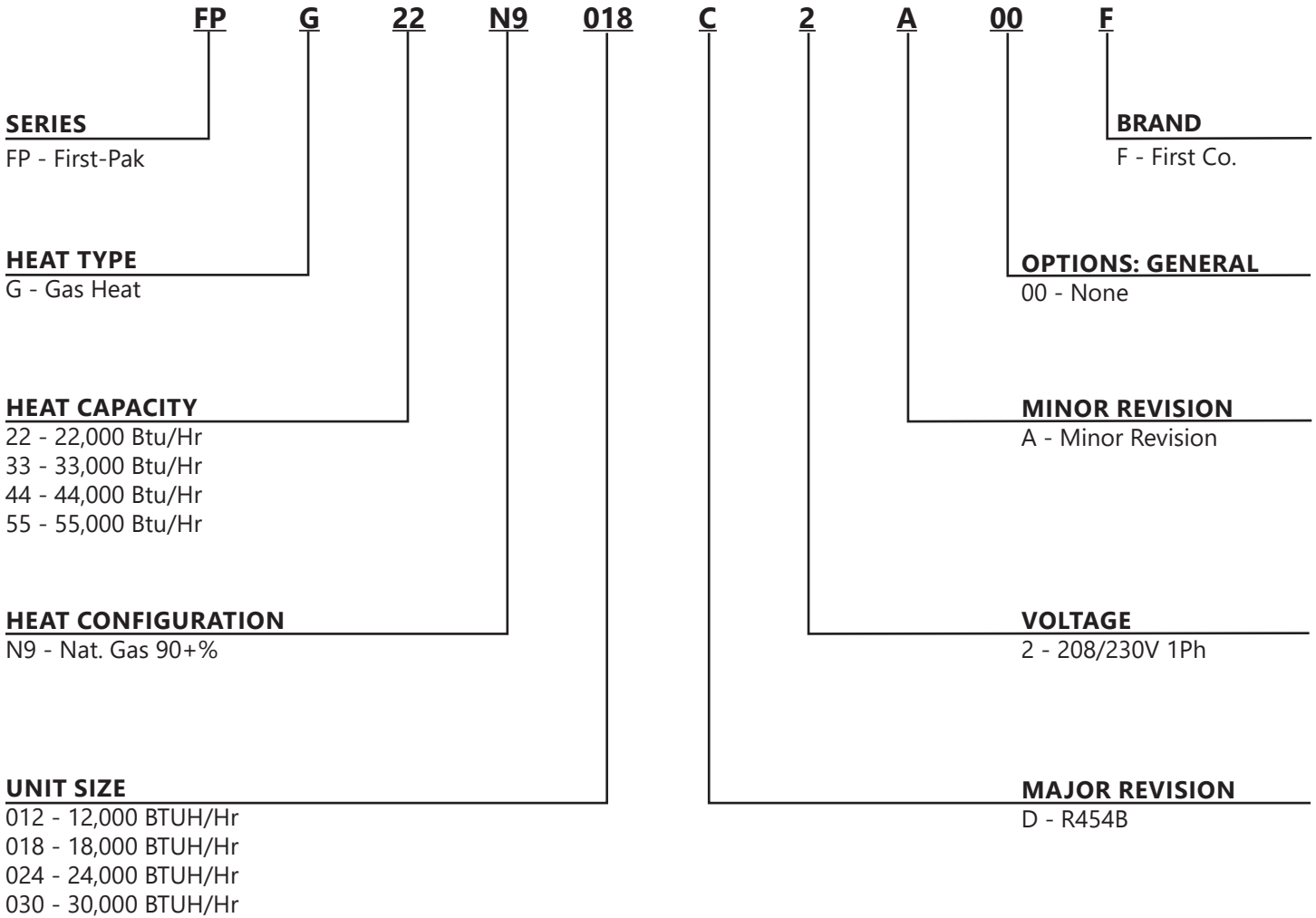

FIRST-PAK GAS 95

SPACE CONSTRAINED VERTICAL UNIT

PRODUCT DESCRIPTION

- Self-contained packaged units with gas fired heating and electric cooling
- Pre-wired and pre-charged with R-454B refrigerant
- Eliminates the need for outdoor condensers, electrical, refrigerant piping, and external venting
- FPG units are compatible with Magic Pak, Comfort Pack and Condo Pack

STANDARD FEATURES

- Blower collar locking mechanism to improve seal between cooling chassis and cabinet
- High efficiency ECM indoor blower motor with multiple speed taps for precise airflow selection
- High efficiency ECM outdoor fan motor to improve system efficiency
- Dual inlet indoor blower to lower fan RPMs, improve efficiency and reduce noise
- High efficiency single stage scroll and rotary compressors
- Double isolated compressor mount to lower compressor noise and vibration
- Larger evaporator coil with low face velocity for improved cooling performance
- Galvanized steel coated drain pan to drain condensate in cooling operation
- Factory installed condensate float switch for overflow protection
- Thermal expansion valve (TXV) to optimize cooling performance
- High and low pressure switch protection
- Stainless steel heat exchanger for corrosion resistance
- Multi-faceted freeze protection; assures reliable unit operation and protection of condensate handling components
- Refrigerant leak mitigation on units over 4lbs of charge

SERVICEABILITY FEATURES

- All electrical components and control board are serviceable from front of the unit
- Slide out cooling chassis for ease of maintenance, service and replacement
- Easily accessible refrigeration service ports located on exterior of cooling chassis with temperature probe area
- Slide out heating section for ease of maintenance, service and replacement
- Sight glass that allows for viewing the control board status codes and main burner function

WARRANTY

5 year limited warranty parts and compressor

ACCESSORIES

- Wall Sleeves
- Architectural Louvers
- High Altitude Kit Part Number - 9KHiAlt95

FIRST-PAK GAS 95

SPACE CONSTRAINED VERTICAL UNIT

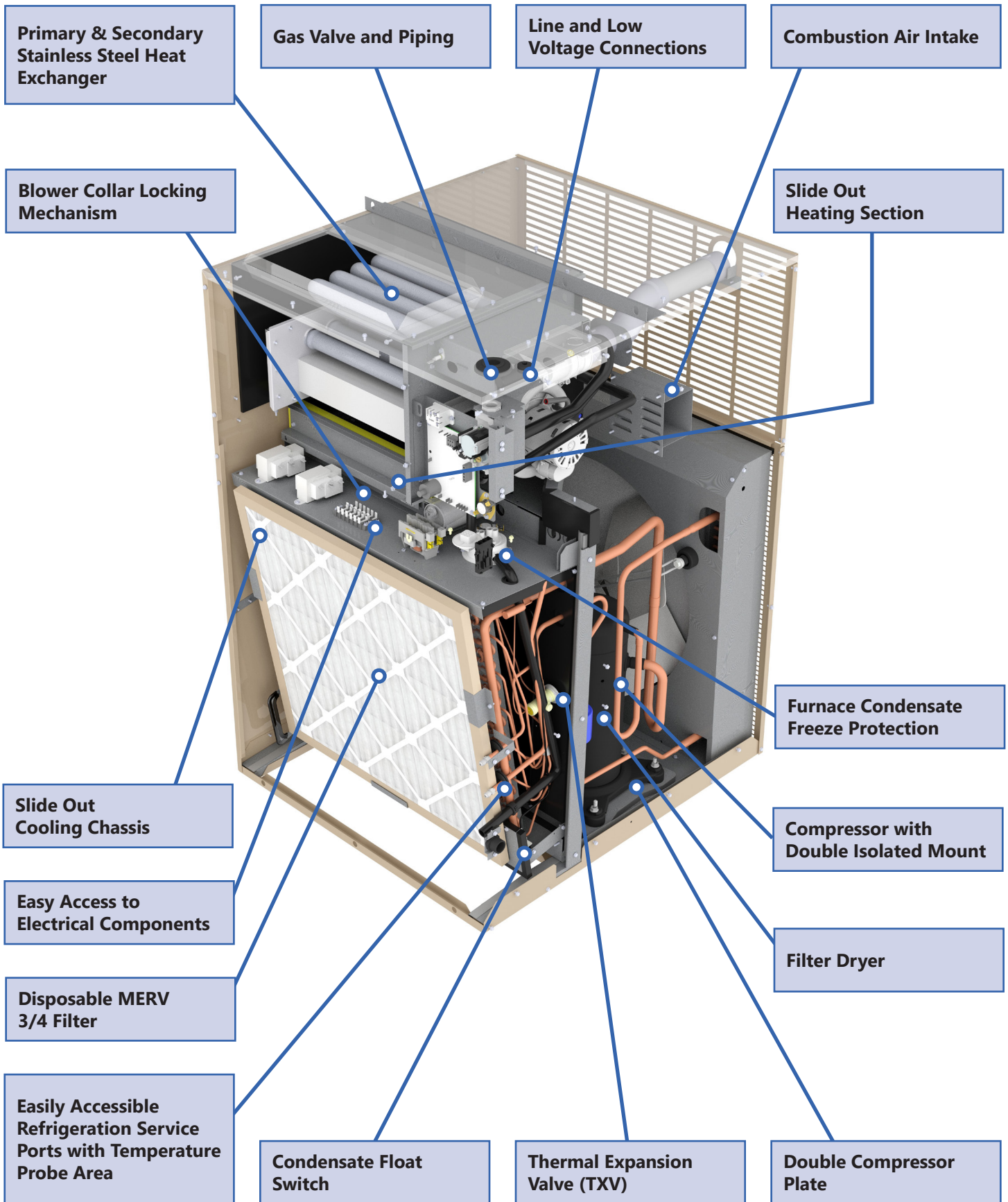

FIRST-PAK GAS 95

SPACE CONSTRAINED VERTICAL UNIT

ACCESSORIES

WALL SLEEVES

- Part number 929-10
- Ships unassembled in carton

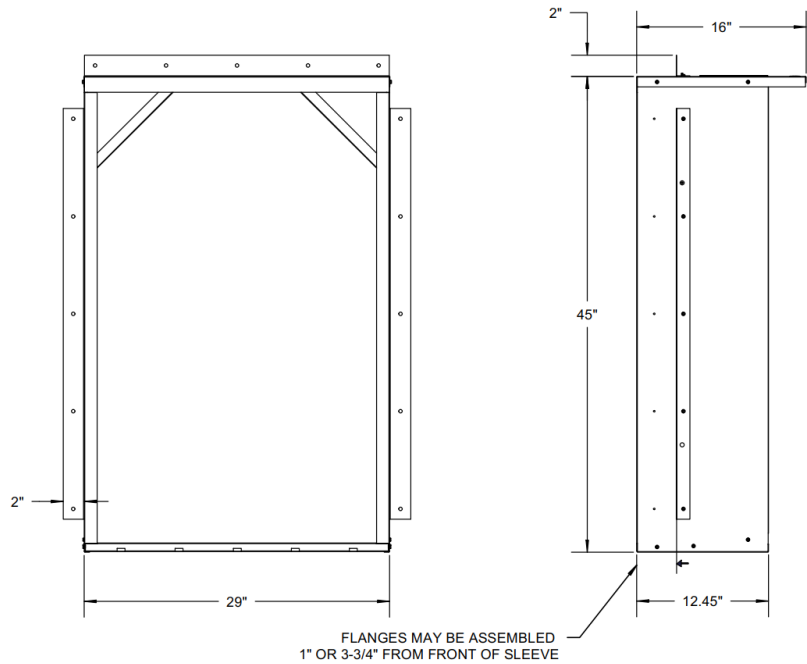

ALUMINUM ARCHITECTURAL LOUVERS (OPTIONAL)

- Part number G2320A Clear Anodized Finish
- Part number G232S* Custom Painted Finish

STANDARD PAINT COLORS

 *ASCOT WHITE (19)	 *LIGHT STONE (43)	 *SHELBURNE (69)
 *BONE WHITE (24)	 *PORTLAND STONE (49)	 *MEDIUM BRONZE (72)
 *CORONADO RED (34)	 *TAUPE (52)	 *DARK BRONZE (75)
 *FOREST GREEN (36)	 *SAHARA TAN (65)	 *STONE GRAY (78)
 *HERRINGBONE (37)	 *SANDSTONE (67)	 *BLACK (89)

*Custom Color with paint matching.

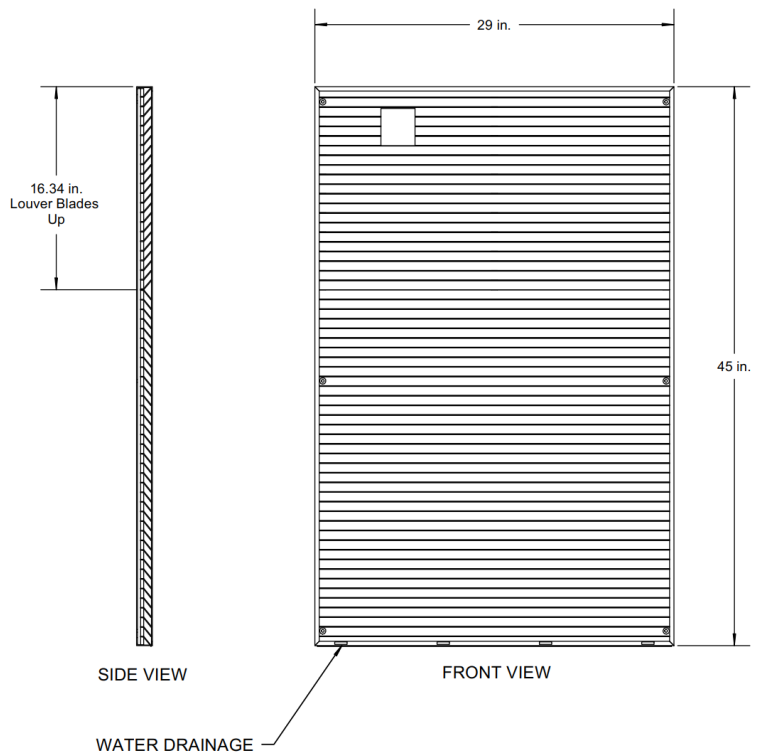

FIRST-PAK GAS 95

SPACE CONSTRAINED VERTICAL UNIT

PHYSICAL DATA

MODEL NUMBER	FPG22N9012D	FPG33N9012D	FPG44N9012D	FPG22N9018D	FPG33N9018D	FPG44N9018D	FPG55N9018D
UNIT INFORMATION							
Compressor Qty/Type	Rotary (1)	Rotary (1)	Rotary (1)	Scroll (1)	Scroll (1)	Scroll (1)	Scroll (1)
Factory Charge (R454B) lbs. [kg]	4.8 [2.18]	4.8 [2.18]	4.8 [2.18]	4.5 [2.04]	4.5 [2.04]	4.5 [2.04]	4.5 [2.04]
Compressor Capacitor	35/370	35/370	35/370	35/370	35/370	35/370	35/370
Condenser Fan HP [kW]	1/5 [.15]	1/5 [.15]	1/5 [.15]	1/5 [.15]	1/5 [.15]	1/5 [.15]	1/5 [.15]
Indoor Fan HP [kW]	1/3 [.25]	1/3 [.25]	1/3 [.25]	1/3 [.25]	1/3 [.25]	1/2 [.37]	1/2 [.37]
Blower Size (D x W) in. [cm]	10 x 6 [25.4 x 15.24]						
Condenser Dimension (H x W) in. [cm]	26.5 x 22.25 [67.3 x 56.5]						
Evaporator Dimension (H x W) in. [cm]	23.15 x 22.25 [58.8 x 56.5]						
Filter Size (H x W) in. [cm]	24 x 24 [60.96 x 60.96]						
Input BTU/h [kW]	22000 [6.4]	33000 [9.7]	44000 [12.9]	22000 [6.4]	33000 [9.7]	44000 [12.9]	55000 [16.1]
Output BTU/h [kW]	21120 [6.2]	31350 [9.2]	41360 [12.1]	21120 [6.2]	31350 [9.2]	41360 [12.1]	51150 [15]
AFUE	96	95	94	96	95	94	93
No. of Burners	2	3	4	2	3	4	5
Orifice Size (Natural Gas) in. [mm]	.0635 [1.61]	.0635 [1.61]	.0635 [1.61]	.0635 [1.61]	.0635 [1.61]	.0635 [1.61]	.0635 [1.61]
Max. Outlet Air Temp °F [°C]	170 [77]	160 [71]	180 [82]	170 [77]	160 [71]	180 [82]	185 [85]
Max. Static Pressure IWC [pa]	0.5 [125]						
Gas Piping Connection in. [mm]	1/2" [12.7]						
Operating Weight lb. [kg]	275 [124.7]	275 [124.7]	280 [127]	295 [133.8]	295 [133.8]	300 [136]	300 [136]
Shipping Weight lb. [kg]	302 [137]	302 [137]	307 [139.2]	322 [146]	322 [146]	327 [148.3]	327 [148.3]

FIRST-PAK GAS 95

SPACE CONSTRAINED VERTICAL UNIT

PHYSICAL DATA (CONT'D)

MODEL NUMBER	FPG33N9024D	FPG44N9024D	FPG55N9024D	FPG44N9030D	FPG55N9030D
UNIT INFORMATION					
Compressor Qty/Type	Scroll (1)	Scroll (1)	Scroll (1)	Scroll (1)	Scroll (1)
Factory Charge (R454B) lbs. [kg]	4.8 [2.18]	4.8 [2.18]	4.8 [2.18]	4 [1.81]	4 [1.81]
Compressor Capacitor	35/370	35/370	35/370	40/370	40/370
Condenser Fan HP [kW]	1/3 [.25]	1/3 [.25]	1/3 [.25]	1/3 [.25]	1/3 [.25]
Indoor Fan HP [kW]	1/3 [.25]	1/2 [.37]	1/2 [.37]	1/2 [.37]	1/2 [.37]
Blower Size (D x W) in. [cm]	10 x 6 [25.4 x 15.24]				
Condenser Dimension (H x W) in. [cm]	26.5 x 22.25 [67.3 x 56.5]				
Evaporator Dimension (H x W) in. [cm]	23.15 x 22.25 [58.8 x 56.5]				
Filter Size (H x W) in. [cm]	24 x 24 [60.96 x 60.96]				
Input BTU/h [kW]	33000 [9.7]	44000 [12.9]	55000 [16.1]	44000 [12.9]	55000 [16.1]
Output BTU/h [kW]	31350 [9.2]	41360 [12.1]	51150 [15]	41360 [12.1]	51150 [15]
AFUE	95	94	93	94	93
No. of Burners	3	4	5	4	5
Orifice Size (Natural Gas) in. [mm]	.0635 [1.61]	.0635 [1.61]	.0635 [1.61]	.0635 [1.61]	.0635 [1.61]
Max. Outlet Air Temp °F [°C]	160 [71]	180 [82]	185 [85]	180 [82]	185 [85]
Max. Static Pressure IWC [pa]	0.5 [125]				
Gas Piping Connection in. [mm]	1/2" [12.7]				
Operating Weight lb. [kg]	325 [147.4]	325 [147.4]	330 [149.7]	340 [154.2]	340 [154.2]
Shipping Weight lb. [kg]	352 [159.7]	352 [159.7]	357 [161.9]	367 [166.5]	367 [166.5]

FILTER SIZE AND PRESSURE DROP (IN W. C.)

MODEL	FILTER SIZE	SUPPLY AIRFLOW (CFM)							
		300	400	500	600	700	800	900	1000
ALL MODELS	24" x 24"	0.008	0.017	0.027	0.036	0.046	0.055	0.065	0.074

FIRST-PAK GAS 95

SPACE CONSTRAINED VERTICAL UNIT

PHYSICAL DATA

UNIT DIMENSIONS

TOP VIEW

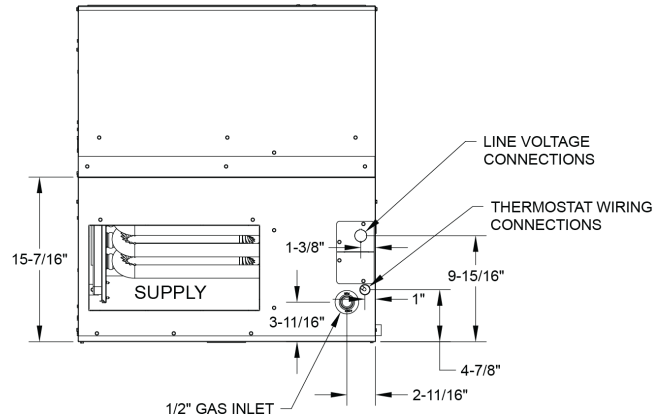

REAR VIEW

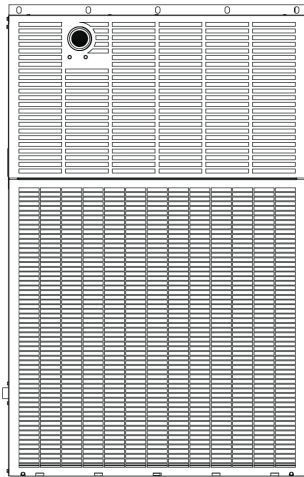

FRONT VIEW

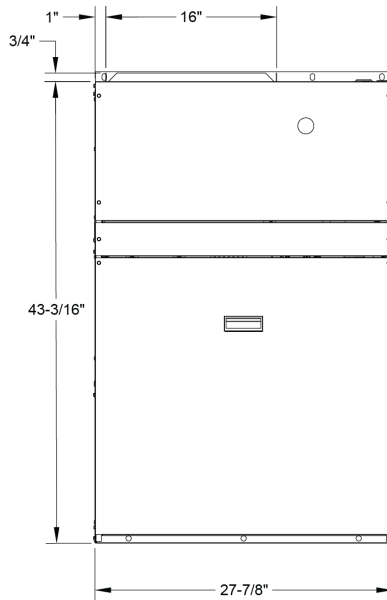

SIDE VIEW

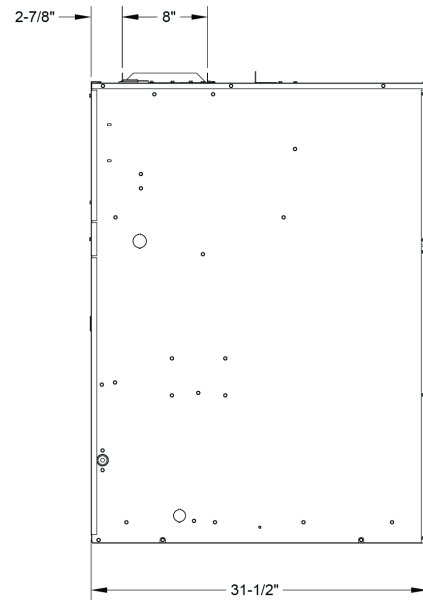

BOTTOM VIEW

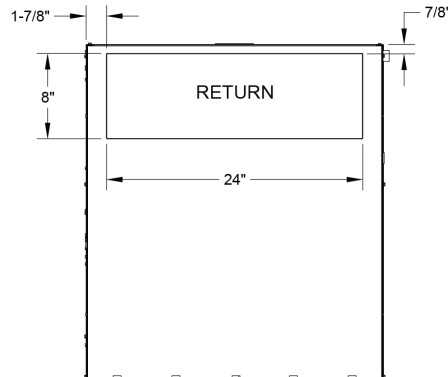

FIRST-PAK GAS 95

SPACE CONSTRAINED VERTICAL UNIT

ELECTRICAL DATA

MODEL NUMBER	VOLTAGE	COMPRES-SOR		OUTDOOR MOTOR		INDOOR MOTOR		MIN.CIRCUIT AMPACITY (MCA)		MAX. OVERCURRENT PROTECTION (MOP)	
		RLA	LRA	FLA	HP	FLA	HP	CIRCUIT 1 (L1-L2)		CIRCUIT 1 (L1-L2)	
								240V	208V	240V	208V
FPG22N9512D2A00F	208/230-1-60	4.6	25	1.9	1/5	2.8	1/3	10	0	15	0
FPG33N9512D2A00F	208/230-1-60	4.6	25	1.9	1/5	2.8	1/3	10	0	15	0
FPG44N9512D2A00F	208/230-1-60	4.6	25	1.9	1/5	4.1	1/2	12	0	15	0
FPG22N9518D2A00F	208/230-1-60	7.2	47	1.9	1/5	2.8	1/3	14	0	20	0
FPG33N9518D2A00F	208/230-1-60	7.2	47	1.9	1/5	2.8	1/3	14	0	20	0
FPG44N9518D2A00F	208/230-1-60	7.2	47	1.9	1/5	4.1	1/2	15	0	20	0
FPG55N9518D2A00F	208/230-1-60	7.2	47	1.9	1/5	4.1	1/2	15	0	20	0
FPG33N9524D2A00F	208/230-1-60	10.2	58	2.8	1/3	2.8	1/3	18	0	25	0
FPG44N9524D2A00F	208/230-1-60	10.2	58	2.8	1/3	4.1	1/2	20	0	25	0
FPG55N9524D2A00F	208/230-1-60	10.2	58	2.8	1/3	4.1	1/2	20	0	25	0
FPG44N9530D2A00F	208/230-1-60	12.8	77	2.8	1/3	4.1	1/2	23	0	35	0
FPG55N9530D2A00F	208/230-1-60	12.8	77	2.8	1/3	4.1	1/2	23	0	35	0

Wire size should be determined in accordance with National Electrical Codes
 Units are rated at 208/230V, but MOP & MCA values are calculated at 208/240V
 Refer to wiring diagram in FPGN9 Installation & Operation Manual for additional details

- RLA** – Rated Load Amps
- LRA** – Locked Rotor Amps
- FLA** – Full Load Amps
- HP** – Horsepower

FIRST-PAK GAS 95

SPACE CONSTRAINED VERTICAL UNIT

RATED COOLING AND HEATING PERFORMANCE

MODEL NUMBER	COOLING						HEATING				
	Btu/hr	EER	SEER	S/T	CFM FULL LOAD	CFM PART LOAD	Heat Cfm	Input Btu/Hr	Output Btu/Hr	AFUE	Temp Rise Range °F
FPG22N9012D*	11000	10.5	11.7	0.85	450	-	490	22000	21120	96	25-55
FPG33N9012D*							650	33000	31350	95	30-60
FPG44N9012D*							850	44000	41360	94	30-60
FPG22N9018D*	16500	10.5	11.7	0.78	650	-	490	22000	21120	96	25-55
FPG33N9018D*							650	33000	31350	95	30-60
FPG44N9018D*							850	44000	41360	94	30-60
FPG55N9018D*							950	55000	51150	93	35-65
FPG33N9024D*	21400	10	11.7	0.78	800	-	650	33000	31350	95	30-60
FPG44N9024D*							850	44000	41360	94	30-60
FPG55N9024D*							950	55000	51150	93	35-65
FPG44N9030D*	25600	9	11.7	0.73	950	700	850	44000	41360	94	30-60
FPG55N9030D*							950	55000	51150	93	35-65

*S/T is not a rated value

EXTENDED COOLING PERFORMANCE DATA

Model	Indoor Temp DB/ WB	Outdoor Temperature °F																	
		65.0			75.0			85.0			95.0			105.0			115.0		
		MBH	S/T	kW	MBH	S/T	kW	MBH	S/T	kW	MBH	S/T	kW	MBH	S/T	kW	MBH	S/T	kW
FPG*N9012D*	75/57	11.2	1.0	0.8	10.7	1.0	0.8	10.2	1.0	0.9	9.8	1.0	1.1	9.3	1.0	1.2	8.8	1.0	1.3
	75/63	12.1	0.8	0.8	11.5	0.8	0.8	10.9	0.9	0.9	10.3	0.9	1.1	9.6	0.9	1.2	9.0	0.9	1.3
	80/67	13.0	0.8	0.8	12.3	0.8	0.8	11.7	0.8	0.9	11.0	0.9	1.1	10.4	0.9	1.2	9.7	0.9	1.3
	85/72	14.1	0.7	0.7	13.4	0.7	0.8	12.7	0.8	0.9	11.9	0.8	1.1	11.2	0.8	1.2	10.5	0.8	1.3
FPG*N9018D*	75/57	16.9	1.0	1.1	16.1	1.0	1.3	15.0	1.0	1.4	14.3	1.0	1.6	13.7	1.0	1.8	13.0	1.0	2.0
	75/63	18.2	0.8	1.1	17.3	0.8	1.3	16.4	0.8	1.4	15.5	0.8	1.6	14.6	0.8	1.8	13.8	0.9	2.0
	80/67	19.4	0.7	1.1	18.5	0.7	1.3	17.6	0.8	1.4	16.6	0.8	1.6	15.7	0.8	1.8	14.7	0.8	2.0
	85/72	21.1	0.7	1.1	20.1	0.7	1.3	19.1	0.7	1.4	18.1	0.7	1.6	17.1	0.7	1.8	16.0	0.8	2.0
FPG*N9024D*	75/57	21.9	1.0	1.5	21.1	1.0	1.7	19.6	1.0	1.9	18.7	1.0	2.1	17.8	1.0	2.3	16.9	1.0	2.5
	75/63	23.6	0.8	1.5	22.5	0.8	1.7	21.3	0.8	1.9	20.1	0.8	2.1	19.0	0.8	2.3	17.9	0.9	2.5
	80/67	25.2	0.7	1.5	24.0	0.8	1.7	22.8	0.8	1.9	21.5	0.8	2.1	20.3	0.8	2.3	19.2	0.8	2.5
	85/72	27.3	0.7	1.5	26.0	0.7	1.7	24.8	0.7	1.9	23.5	0.7	2.1	22.0	0.7	2.3	20.7	0.8	2.5
FPG*N9030D*	75/57	25.6	1.0	2.1	24.5	1.0	2.3	23.6	1.0	2.5	22.8	1.0	2.7	21.3	1.0	2.9	20.3	1.0	3.2
	75/63	28.2	0.7	2.1	26.9	0.7	2.3	25.7	0.7	2.5	24.4	0.8	2.7	23.0	0.8	2.9	21.8	0.8	3.2
	80/67	30.0	0.7	2.2	28.7	0.7	2.3	27.3	0.7	2.5	25.9	0.7	2.7	24.6	0.8	2.9	23.2	0.8	3.2
	85/72	32.5	0.6	2.2	31.0	0.6	2.4	29.4	0.6	2.5	27.9	0.7	2.7	26.5	0.7	2.9	25.1	0.7	3.2

* Total power input of the unit

Performance data is simulated based on the rated value of each model and is calculated based on nominal CFM and .3 external static pressure

This data is to be used as reference values only and does not constitute a rating or a guarantee that the installed system will perform as indicated

FIRST-PAK GAS 95

SPACE CONSTRAINED VERTICAL UNIT

BLOWER PERFORMANCE

MODEL	Motor Tap	Mid Rise °F	Rise Range °F	IWC STATIC PRESSURE									
				0.1		0.2		0.3		0.4		0.5	
				SCFM	Temp Rise °F	SCFM	Temp Rise °F	SCFM	Temp Rise °F	SCFM	Temp Rise °F	SCFM	Temp Rise °F
FPG22N9012D*	1	40	25-55	337		301		266		233		203	
	2		25-55	337		301		266		233		203	
	3 ^H		25-55	561	35	525	37	490	40	458	43	427	46
	4 ^C		25-55	531	37	494	40	460	43	427	46	396	49
	5		25-55	606	32	569	34	534	37	502	39	471	42
FPG33N9012D*	1	45	30-60	325		287		253		221		189	
	2		30-60	325		287		253		221		189	
	3 ^H		30-60	786	37	748	39	714	41	682	43	650	45
	4 ^C		30-60	530	55	492	59	458		426		393	
	5		30-60	607	48	569	51	535	54	503	58	471	
FPG44N9012D*	1	45	30-60	325		287		253		221		189	
	2		30-60	325		287		253		221		189	
	3 ^H		30-60	786	49	748	51	714	54	682	56	650	59
	4 ^C		30-60	530		492		458		426		393	
	5		30-60	607		569		535		503		471	
FPG22N9018D*	1	40	25-55	337		301		266		233		203	
	2		25-55	337		301		266		233		203	
	3 ^H		25-55	561	35	525	37	490	40	458	43	427	46
	4 ^C		25-55	708	28	671	29	637	31	604	32	573	34
	5		25-55	1015	19	978	20	944	21	911	21	880	22
FPG33N9018D*	1	45	30-60	325		287		253		221		189	
	2		30-60	325		287		253		221		189	
	3 ^H		30-60	786	37	748	39	714	41	682	43	650	45
	4 ^C		30-60	708	41	670	43	636	46	604	48	572	51
	5		30-60	1008	29	971	30	937	31	904	32	872	33
FPG44N9018D*	1	45	30-60	405		374		341		311		283	
	2		30-60	405		374		341		311		283	
	3 ^H		30-60	972	39	941	41	908	42	878	44	850	45
	4 ^C		30-60	682	56	650	59	618		587		559	
	5		30-60	972	39	941	41	908	42	878	44	850	45
FPG55N9018D*	1	50	35-65	403		373		342		312		283	
	2		35-65	403		373		342		312		283	
	3 ^H		35-65	1104	43	1074	44	1042	45	1012	47	984	48
	4 ^C		35-65	695		665		634		604		575	
	5		35-65	965	49	935	51	904	52	874	54	845	56

Airflow data shown is with dry coil at 70°F DB EAT with standard 1" air filter.

For models with five speed taps, tap T1 is for ventilation. T3 is for heating operation. T2 is for freeze protection. T4-T5 is for cooling operation

Superscript ^C indicates factory-set default cooling tap. Superscript ^H indicates factory-set default heating tap.

FIRST-PAK GAS 95

SPACE CONSTRAINED VERTICAL UNIT

BLOWER PERFORMANCE (CONT'D)

MODEL	Motor Tap	Mid Rise °F	Rise Range °F	IWC STATIC PRESSURE									
				0.1		0.2		0.3		0.4		0.5	
				SCFM	Temp Rise °F	SCFM	Temp Rise °F	SCFM	Temp Rise °F	SCFM	Temp Rise °F	SCFM	Temp Rise °F
FPG33N9024D*	1	45	35-65	392		339		305		273		241	
	2		35-65	377		339		305		273		241	
	3 ^H		35-65	722	40	684	42	650	45	618	47	586	50
	4 ^C		35-65	863	34	825	35	791	37	758	38	726	40
	5		35-65	1008	29	971	30	937	31	904	32	872	33
FPG44N9024D*	1	45	30-60	405		373		338		304		271	
	2		30-60	405		373		338		304		271	
	3 ^H		30-60	912	42	880	44	845	45	810	47	778	49
	4 ^C		30-60	863	44	831	46	796	48	761	50	728	53
	5		30-60	1012	38	980	39	945	41	910	42	877	44
FPG55N9024D*	1	50	30-60	404		375		342		310		279	
	2		30-60	404		375		342		310		279	
	3 ^H		30-60	1040	46	1011	47	978	48	946	50	915	52
	4 ^C		30-60	863	55	834	57	801	59	768	62	738	64
	5		30-60	1013	47	985	48	952	50	919	52	889	53
FPG44N9030D*	1	45	35-65	649	59	617	62	582		547		515	
	2		35-65	649	59	617	62	582		547		515	
	3 ^H		35-65	912	42	880	44	845	45	810	47	778	49
	4 ^C		35-65	797	48	765	50	730	52	695	55	663	58
	5		35-65	991	39	959	40	924	41	889	43	857	45
FPG55N9030D*	1	50	35-65	646		617		584		552		521	
	2		35-65	646		617		584		552		521	
	3 ^H		35-65	1040	46	1011	47	978	48	946	50	915	52
	4 ^C		35-65	760	62	731	65	699		666		635	
	5		35-65	988	48	959	49	926	51	893	53	863	55

Airflow data shown is with dry coil at 70°F DB EAT with standard 1" air filter.

For models with five speed taps, tap T1 is for ventilation. T3 is for heating operation. T2 is for freeze protection. T4-T5 is for cooling operation

Superscript ^C indicates factory-set default cooling tap. Superscript ^H indicates factory-set default heating tap.

Data is subject to change. Please verify current information on www.firstco.com.





AMERICAN-MADE. FAMILY OWNED.



FIRST CO.
P.O. BOX 270969 - DALLAS, TEXAS 75227
PH. (214) 388-5751 | FAX (214) 388-2255
WWW.FIRSTCO.COM

SEPTEMBER 2024