



# FIRST-PAK<sup>®</sup> GAS

## Single Package Vertical Gas Unit (FPGN9)

- 1.0 - 2.5 Tons
- Up to 55,000 BTU/Hr Heating
- Up to 96% AFUE
- 11.7 SEER 2



R454B

# Nomenclature

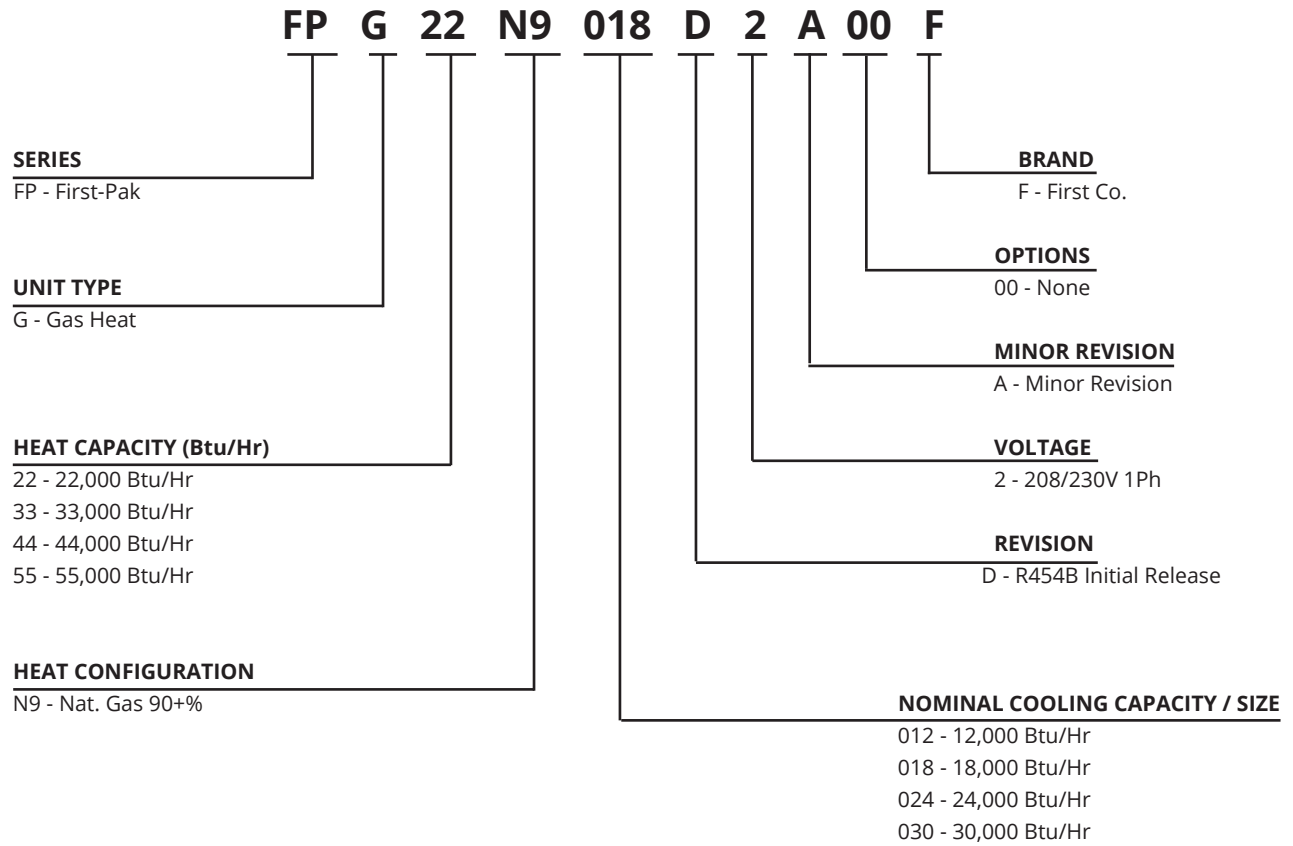

## PRODUCT DESCRIPTION

- Self-contained packaged units with gas fired heating and electric cooling
- Pre-wired and pre-charged with R-454B refrigerant
- Eliminates the need for outdoor condensers, electrical, refrigerant piping, and external venting
- FPG units are compatible with Magic Pak, Comfort Pack and Condo Pack

## STANDARD FEATURES

- Blower collar locking mechanism to improve seal between cooling chassis and cabinet
- High efficiency ECM indoor blower motor with multiple speed taps for precise airflow selection
- High efficiency ECM outdoor fan motor to improve system efficiency
- Dual inlet indoor blower to lower fan RPMs, improve efficiency and reduce noise
- High efficiency single stage scroll and rotary compressors
- Double isolated compressor mount to lower compressor noise and vibration
- Larger evaporator coil with low face velocity for improved cooling performance
- Galvanized steel coated drain pan to drain condensate in cooling operation
- Factory installed condensate float switch for overflow protection
- Thermal expansion valve (TXV) to optimize cooling performance
- High and low pressure switch protection
- Stainless steel heat exchanger for corrosion resistance
- Multi-faceted freeze protection; assures reliable unit operation and protection of condensate handling components

## SERVICEABILITY FEATURES

- All electrical components and control board are serviceable from front of the unit
- Slide out cooling chassis for ease of maintenance, service and replacement
- Easily accessible refrigeration service ports located on exterior of cooling chassis with temperature probe area
- Slide out heating section for ease of maintenance, service and replacement
- Sight glass that allows for viewing the control board status codes and main burner function

## WARRANTY

- Five (5) years limited parts on compressor and parts for the cooling side
- Twenty (20) years limited on heat exchanger

## ACCESSORIES

- Wall Sleeves
- Architectural Louvers
- High Altitude Kit Part Number - 9KHiAlt95

# Features & Benefits

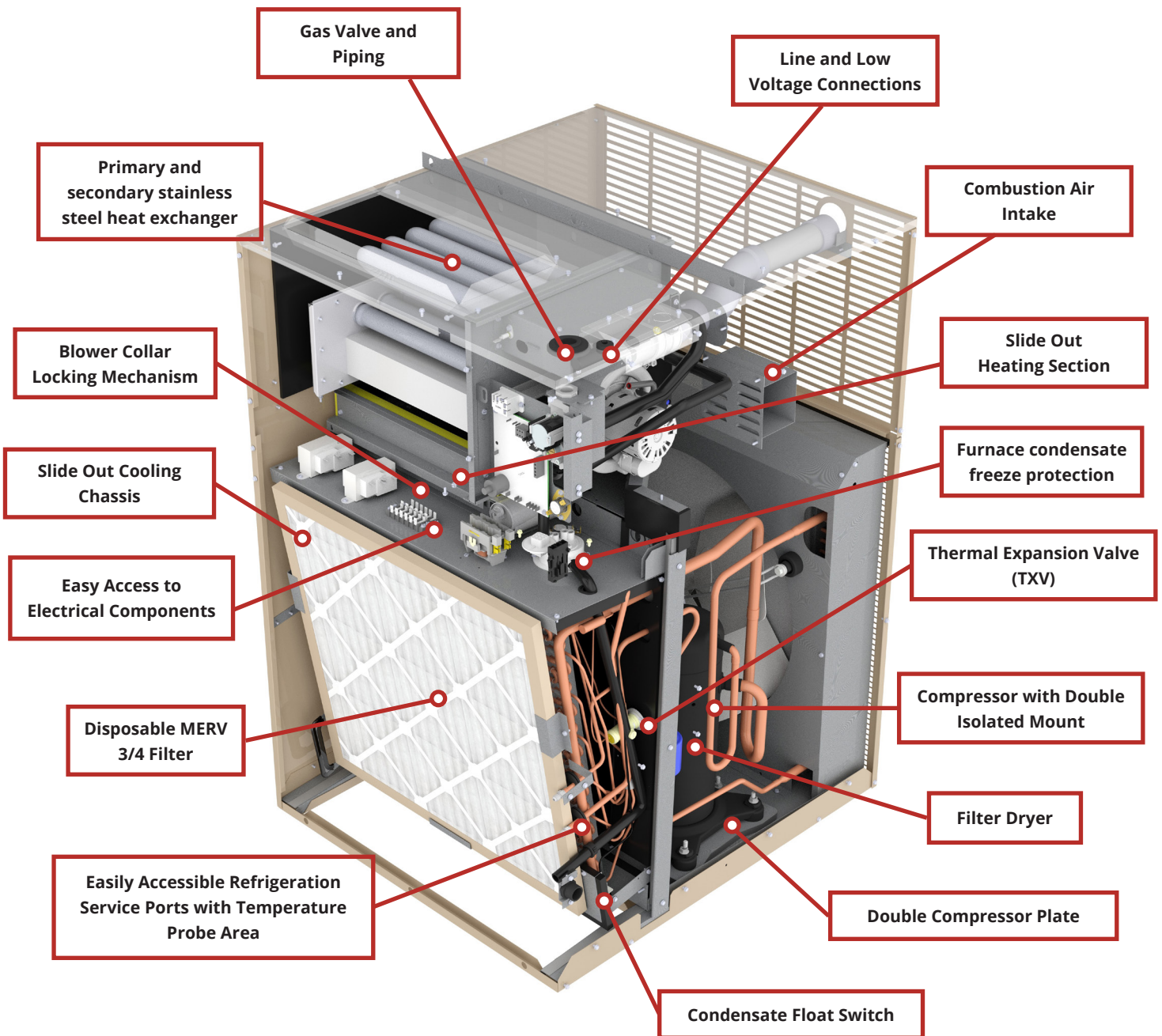

# Accessories

## WALL SLEEVES

- Part number 929-10
- Ships unassembled in carton

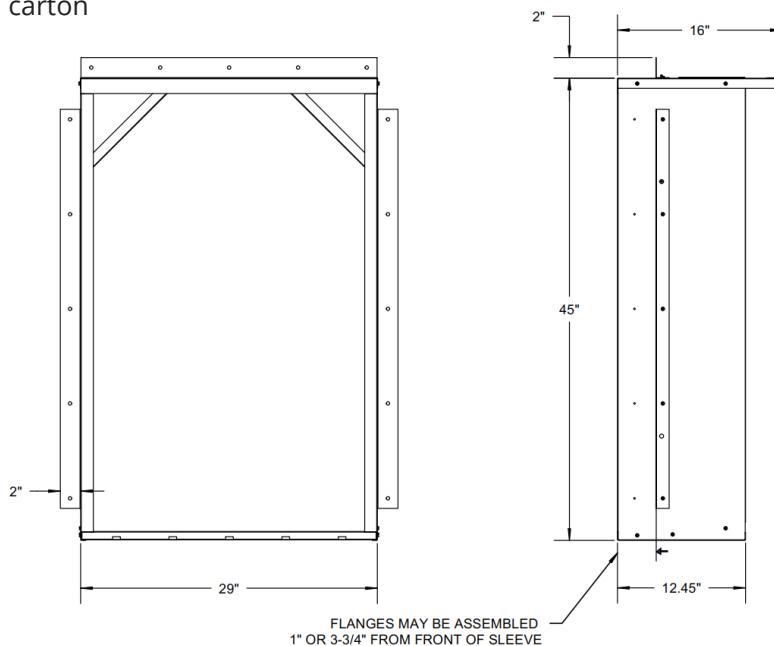

## ALUMINUM ARCHITECTURAL LOUVERS (OPTIONAL)

- Part number G232A Clear Anodized Finish
- Part number G232S\* Custom Painted Finish

### Standard Paint Colors

\*Custom color with paint matching.

*ASCOT WHITE (19)	*LIGHT STONE (43)	*SHELburnE (69)
*BONE WHITE (24)	*PORTLAND STONE (49)	*MEDIUM BRONZE (72)
*CORONADO RED (34)	*TAUPE (52)	*DARK BRONZE (75)
*FOREST GREEN (36)	*SAHARA TAN (65)	*STONE GRAY (78)
*HERRINGBONE (37)	*SANDSTONE (67)	*BLACK (89)

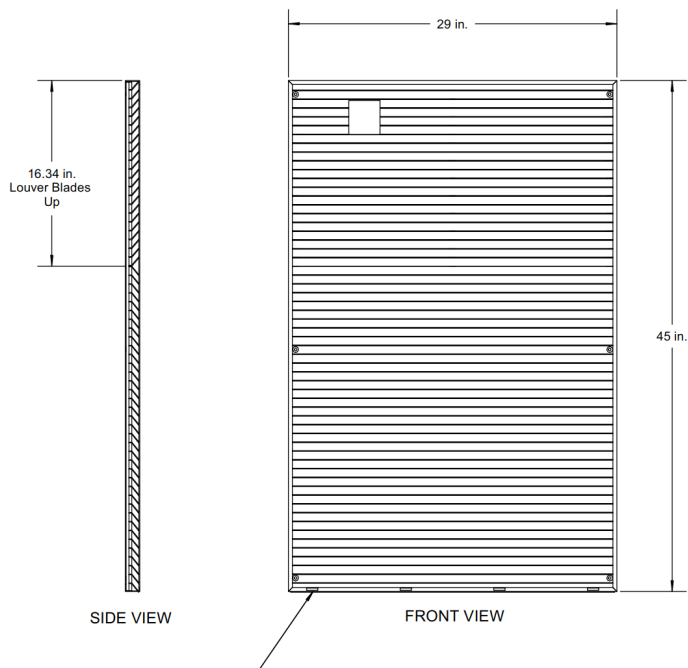

# Physical Data

MODEL NUMBER	FPG22N9012D	FPG33N9012D	FPG44N9012D	FPG22N9018D	FPG33N9018D	FPG44N9018D	FPG55N9018D
Compressor Type (Qty)	Rotary (1)	Rotary (1)	Rotary (1)	Rotary (1)	Rotary (1)	Rotary (1)	Rotary (1)
Factory Charge (R-454B) lbs. [kg]	3.75 [1.70]	3.75 [1.70]	3.75 [1.70]	4.8 [2.18]	4.8 [2.18]	4.8 [2.18]	4.8 [2.18]
Compressor Capacitor	35MFD/370V	35MFD/370V	35MFD/370V	40MFD/370V	40MFD/ 370V	40MFD/ 370V	40MFD/ 370V
Outdoor Fan HP [kW]	1/5 [.15]	1/5 [.15]	1/5 [.15]	1/5 [.15]	1/5 [.15]	1/5 [.15]	1/5 [.15]
Indoor Fan HP [kW]	1/3 [.25]	1/3 [.25]	1/3 [.25]	1/3 [.25]	1/3 [.25]	1/2 [.37]	1/2 [.37]
Indoor Blower Size (D X W) in. [mm]	10 x 6 [25.4 x 15.24]						
Condenser Coil Dimensions (H x W) in. [mm]	26.5 x 22.25 [67.3 x 56.5]						
Evaporator Coil Dimensions (H x W) in. [cm]	23.1 x 22.25 [58.7 x 56.5]						
Filter Size (H x W) in. [cm]	24 x 24 [60.96 x 60.96]						
Input BTU/H [kW]	22000 [6.4]	33000 [9.7]	44000 [12.9]	22000 [6.4]	33000 [9.7]	44000 [12.9]	55000 [16.1]
Output BTU/H [kW]	21120 [6.2]	31350 [9.2]	41360 [12.1]	21120 [6.2]	31350 [9.2]	41360 [12.1]	51150 [15]
AFUE	96	95	94	96	95	94	93
No. of Burners	2	3	4	2	3	4	5
Orifice Size (Natural) in. [mm]	.0635 [1.61]	.0635 [1.61]	.0635 [1.61]	.0635 [1.61]	.0635 [1.61]	.0635 [1.61]	.0635 [1.61]
Max. Outlet Air Temp. °F [°C]	170 [77]	160 [71]	180 [82]	170 [77]	160 [71]	180 [82]	185 [85]
Max. External Static Pressure in. w.c. [pa]	.5" [125]						
Gas Piping Connection NPT in.	1/2" [1.27]						
Operating Weight lbs. [kg]	271 [123]	273 [124]	275 [125]	293 [133]	295 [134]	297 [135]	299 [136]
Shipping Weight lbs. [kg]	298 [135]	300 [136]	302 [137]	320 [145]	322 [146]	324 [147]	326 [148]

# Physical Data

Continued

MODEL NUMBER	FPG33N9024D	FPG44N9024D	FPG55N9024D	FPG44N9030D	FPG55N9030D
Compressor Type (Qty)	Scroll (1)	Scroll (1)	Scroll (1)	Scroll (1)	Scroll (1)
Factory Charge (R-454B) lbs. [kg]	4.9 [2.21]	4.9 [2.21]	4.9 [2.21]	5.0 [2.27]	5.0 [2.27]
Compressor Capacitor	35MFD/ 370V	35MFD/ 370V	35MFD/370V	40MFD/370V	40MFD/370V
Outdoor Fan HP [kW]	1/3 [.25]	1/3 [.25]	1/3 [.25]	1/3 [.25]	1/3 [.25]
Indoor Fan HP [kW]	1/3 [.25]	1/2 [.37]	1/2 [.37]	1/2 [.37]	1/2 [.37]
Indoor Blower Size (D X W) in. [mm]	10 x 6 [25.4 x 15.24]				
Condenser Coil Dimensions (H x W) in. [mm]	26.5 x 22.25 [67.3 x 56.5]				
Evaporator Coil Dimensions (H x W) in. [cm]	23.1 x 22.25 [58.7 x 56.5]				
Filter Size (H x W) in. [cm]	24 x 24 [60.96 x 60.96]				
Input BTU/H [kW]	33000 [9.7]	44000 [12.9]	55000 [16.1]	44000 [12.9]	55000 [16.1]
Output BTU/H [kW]	31350 [9.2]	41360 [12.1]	51150 [15]	41360 [12.1]	51150 [15]
AFUE	95	94	93	94	93
No. of Burners	3	4	5	4	5
Orifice Size (Natural) in. [mm]	.0635 [1.61]	.0635 [1.61]	.0635 [1.61]	.0635 [1.61]	.0635 [1.61]
Max. Outlet Air Temp. °F [°C]	160 [71]	180 [82]	185 [85]	180 [82]	185 [85]
Max. External Static Pressure in. w.c. [pa]	.5 [125]				
Gas Piping Connection NPT in.	0.5 [1.27]				
Operating Weight lbs. [kg]	322 [146]	324 [147]	326 [148]	338 [153]	340 [154]
Shipping Weight lbs. [kg]	349 [158]	351 [159]	353 [160]	365 [165]	367 [166]

## Filter Size & Pressure Drop (in. w.c.)

MODEL	FILTER SIZE	SUPPLY AIRFLOW (CFM)							
		300	400	500	600	700	800	900	1000
ALL MODELS	24" x 24"	0.008	0.017	0.027	0.036	0.046	0.055	0.065	0.074

# Physical Data

## Unit Dimensions

TOP VIEW

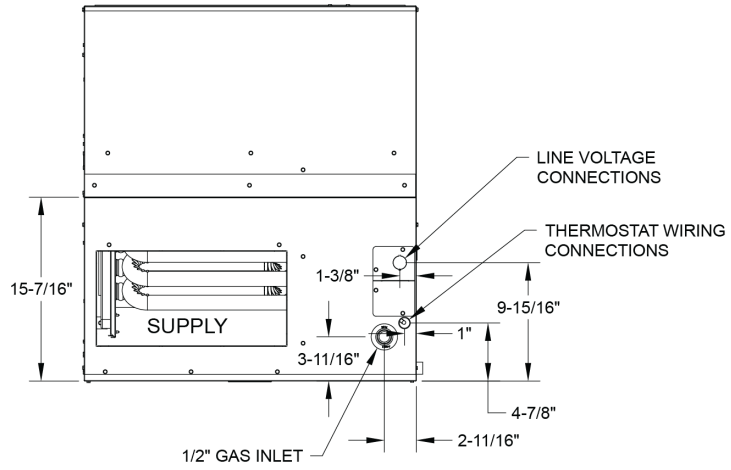

REAR VIEW

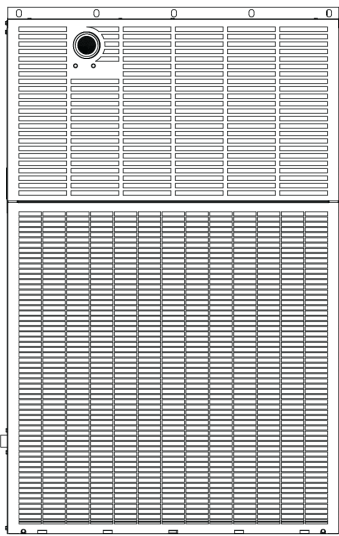

FRONT VIEW

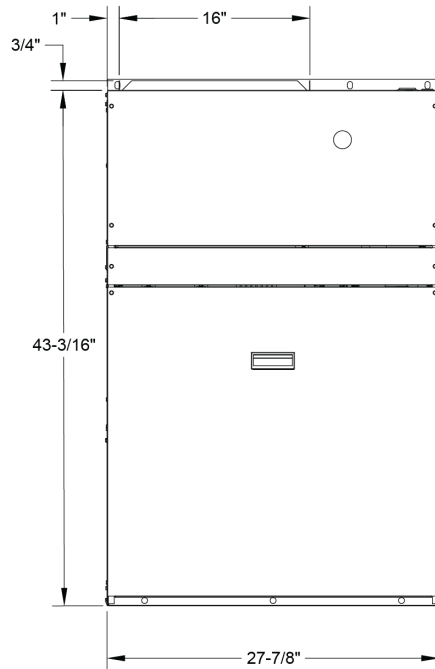

SIDE VIEW

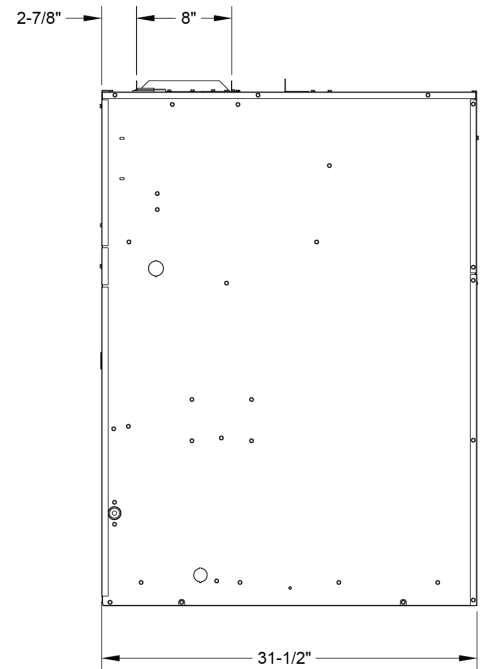

BOTTOM VIEW

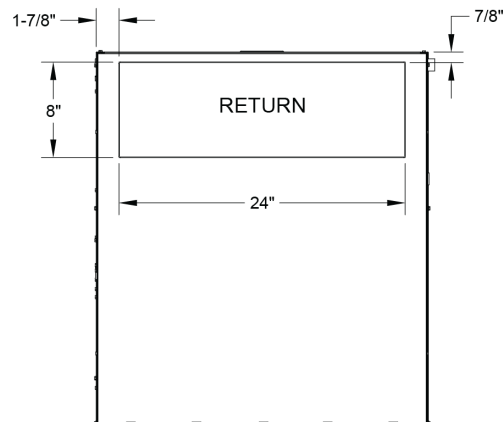



# Electrical Data

MODEL NUMBER	VOLTAGE PH-HZ	COMPRESSOR		CONDENSOR MOTOR		INDOOR MOTOR		MIN. CIRCUIT AMPACITY	MAX. CIRCUIT PROTECTION	MIN. VOLT.	MAX. VOLT.
		RLA	LRA	FLA	HP	FLA	HP				
FPG22N9012D	208/230-1-60	5.5	25	2.8	1/3	2.8	1/3	12.5	15	187	252
FPG33N9012D	208/230-1-60	5.5	25	2.8	1/3	2.8	1/3	12.5	15	187	252
FPG44N9012D	208/230-1-60	5.5	25	2.8	1/3	4.1	1/2	13.8	15	187	252
FPG22N9018D	208/230-1-60	7.6	35	2.8	1/3	2.8	1/3	15.1	20	187	252
FPG33N9018D	208/230-1-60	7.6	35	2.8	1/3	2.8	1/3	15.1	20	187	252
FPG44N9018D	208/230-1-60	7.6	35	2.8	1/3	4.1	1/2	16.4	20	187	252
FPG55N9018D	208/230-1-60	7.6	35	2.8	1/3	4.1	1/2	16.4	20	187	252
FPG33N9024D	208/230-1-60	9.0	63	2.8	1/3	2.8	1/3	16.8	25	187	252
FPG44N9024D	208/230-1-60	9.0	63	2.8	1/3	4.1	1/2	18.1	25	187	252
FPG55N9024D	208/230-1-60	9.0	63	2.8	1/3	4.1	1/2	18.1	25	187	252
FPG44N9030D	208/230-1-60	12.5	67	2.8	1/3	4.1	1/2	22.5	35	187	252
FPG55N9030D	208/230-1-60	12.5	67	2.8	1/3	4.1	1/2	22.5	35	187	252

Wire size should be determined in accordance with National Electrical Codes

Units are rated at 208/230V, but MOP & MCA values are calculated at 208/240V

Refer to wiring diagram in FPGN9 Installation & Operation Manual for additional details

RLA - Rated Load Amps

LRA - Locked Rotor Amps

FLA - Full Load Amps

HP - Horsepower

# Rated Cooling & Heating Performance

MODEL NUMBER	COOLING						HEATING				
	NET CAPACITY (BTU/H)	EER2	SEER2	S/T*	FULL LOAD CFM	PART LOAD CFM	CFM	INPUT (BTU/H)	OUTPUT (BTU/H)	AFUE (%)	TEMP. RISE RANGE (°F)
FPG22N9012D	12,000	10.0	11.7	0.75	450	-	490	22,000	21,120	96	25-55
FPG33N9012D							650	33,000	31,350	95	30-60
FPG44N9012D							850	44,000	41,360	94	30-60
FPG22N9018D	16,500	10.0	11.7	0.78	630	-	490	22,000	21,120	96	25-55
FPG33N9018D							650	33,000	31,350	95	30-60
FPG44N9018D							850	44,000	41,360	94	30-60
FPG55N9018D							950	5,000	51,150	93	35-65
FPG33N9024D	22,000	10.0	11.7	0.74	780	-	650	33,000	31,350	95	30-60
FPG44N9024D							850	44,000	41,360	94	30-60
FPG55N9024D							950	55,000	51,150	93	35-65
FPG44N9030D	26,000	9.0	11.7	0.74	920	620	850	44,000	41,360	94	30-60
FPG55N9030D							950	55,000	51,150	93	35-65

\*S/T is not a rated value

# Extended Cooling Performance Data

MODEL NUMBER	INDOOR TEMP DB/WB (°F)	OUTDOOR TEMPERATURE (°F)														
		65.0			85.0			95.0			105.0			115.0		
		MBH	S/T	kW*	MBH	S/T	kW*	MBH	S/T	kW*	MBH	S/T	kW*	MBH	S/T	kW*
FPG**N*012D	75/57	13.2	1.0	0.9	12.1	1.0	1.1	12.1	1.0	1.2	11.0	1.0	1.3	10.4	1.0	1.4
	75/63	14.2	0.8	0.9	12.9	0.8	1.1	12.9	0.8	1.2	11.5	0.9	1.3	10.8	0.9	1.5
	80/67	15.2	0.8	0.9	13.8	0.8	1.1	13.8	0.8	1.2	12.3	0.9	1.3	11.6	0.9	1.5
	85/72	16.4	0.7	0.9	14.9	0.7	1.1	14.9	0.7	1.2	13.4	0.8	1.4	12.6	0.8	1.5
FPG**N*018D	75/57	18.4	1.0	1.2	16.8	1.0	1.4	15.9	1.0	1.5	15.0	1.0	1.6	14.1	1.0	1.8
	75/63	19.6	0.8	1.3	17.6	0.8	1.4	16.5	0.8	1.5	15.4	0.8	1.6	14.0	0.8	1.8
	80/67	20.7	0.7	1.3	18.6	0.8	1.4	17.5	0.8	1.6	16.2	0.8	1.7	14.2	1.0	1.8
	85/72	22.2	0.7	1.3	20.0	0.7	1.5	19.0	0.8	1.6	17.3	0.7	1.7	15.6	0.7	1.8
FPG**N*024D	75/57	23.9	1.0	1.7	21.4	1.0	2.0	20.4	1.0	2.2	19.3	1.0	2.4	18.3	1.0	2.7
	75/63	25.7	0.8	1.7	23.2	0.8	2.0	21.9	0.8	2.2	20.7	0.8	2.4	19.4	0.9	2.7
	80/67	27.5	0.7	1.7	24.8	0.8	2.0	23.5	0.8	2.2	22.2	0.8	2.5	20.8	0.8	2.7
	85/72	29.7	0.7	1.7	26.9	0.7	2.0	25.5	0.7	2.3	24.1	0.7	2.5	22.6	0.8	2.7
FPG**N*030D	75/57	27.5	1.0	2.2	25.2	1.0	2.5	24.0	1.0	2.8	22.7	1.0	3.0	21.5	1.0	3.3
	75/63	30.1	0.7	2.2	27.1	0.8	2.5	25.6	0.8	2.8	24.0	0.8	3.0	22.5	0.8	3.3
	80/67	31.6	0.7	2.2	28.4	0.8	2.5	26.9	0.8	2.8	25.2	0.8	3.1	23.6	0.9	3.4
	85/72	33.9	0.7	2.2	30.6	0.7	2.6	28.9	0.7	2.8	26.8	0.7	3.1	25.8	0.8	3.4

\* Total power input of the unit

Performance data is simulated based on the rated value of each model and is calculated based on nominal CFM and .3 external static pressure

This data is to be used as reference values only and does not constitute a rating or a guarantee that the installed system will perform as indicated

# Blower Performance

MODEL NUMBER	Motor Speed	Mid Rise °F	Rise Range °F	IWC STATIC PRESSURE									
				0.10		0.20		0.30		0.40		0.50	
				SCFM	Temp Rise °F	SCFM	Temp Rise °F	SCFM	Temp Rise °F	SCFM	Temp Rise °F	SCFM	Temp Rise °F
FPG22N9012D*	T1	40.0	25-55	337	58	301		266		233		203	
	T2		25-55	337	58	301		266		233		203	
	T3 <sup>H</sup>		25-55	561	35	525	37	490	40	458	43	427	46
	T4 <sup>C</sup>		25-55	531	37	494	40	460	43	427	46	396	49
	T5		25-55	606	32	569	34	534	37	502	39	471	42
FPG33N9012D*	T1	45.0	30-60	325		287		253		221		189	
	T2		30-60	325		287		253		221		189	
	T3 <sup>H</sup>		30-60	786	37	748	39	714	41	682	43	650	45
	T4 <sup>C</sup>		30-60	530	55	492	59	458		426		393	
	T5		30-60	607	48	569	51	535	54	503	58	471	
FPG44N9012D*	T1	45.0	30-60	405		374		341		311		283	
	T2		30-60	405		374		341		311		283	
	T3 <sup>H</sup>		30-60	972	39	941	41	908	42	878	44	850	45
	T4 <sup>C</sup>		30-60	527		495		463		432		404	
	T5		30-60	593		561		529		499		470	
FPG22N9018D*	T1	40.0	25-55	337	58	301		266		233		203	
	T2		25-55	337	58	301		266		233		203	
	T3 <sup>H</sup>		25-55	561	35	525	37	490	40	458	43	427	46
	T4 <sup>C</sup>		25-55	708	28	671	29	637	31	604	32	573	34
	T5		25-55	1015	19	978	20	944	21	911	21	880	22
FPG33N9018D*	T1	45.0	30-60	325		287		253		221		189	
	T2		30-60	325		287		253		221		189	
	T3 <sup>H</sup>		30-60	786	37	748	39	714	41	682	43	650	45
	T4 <sup>C</sup>		30-60	708	41	670	43	636	46	604	48	572	51
	T5		30-60	1008	29	971	30	937	31	904	32	872	33
FPG44N9018D*	T1	45.0	30-60	405		374		341		311		283	
	T2		30-60	405		374		341		311		283	
	T3 <sup>H</sup>		30-60	972	39	941	41	908	42	878	44	850	45
	T4 <sup>C</sup>		30-60	700	55	668	57	636		605		577	
	T5		30-60	972	39	941	41	908	42	878	44	850	45
FPG55N9018D*	T1	50.0	35-65	403		373		342		312		283	
	T2		35-65	403		373		342		312		283	
	T3 <sup>H</sup>		35-65	1104	43	1074	44	1042	45	1012	47	984	48
	T4 <sup>C</sup>		35-65	698		668		637		607		578	
	T5		35-65	965	49	935	51	904	52	874	54	845	56

Airflow data shown is with dry coil at 70°F DB EAT with standard 1" air filter.

For models with five speed taps, tap T1 is for ventilation. T3 is for heating operation. T2 is for freeze protection. T4-T5 is for cooling operation. Superscript <sup>C</sup> indicates factory-set default cooling tap. Superscript <sup>H</sup> indicates factory-set default heating tap.

# Blower Performance

Continued

MODEL NUMBER	Motor Speed	Mid Rise °F	Rise Range °F	IWC STATIC PRESSURE									
				0.10		0.20		0.30		0.40		0.50	
				SCFM	Temp Rise °F	SCFM	Temp Rise °F	SCFM	Temp Rise °F	SCFM	Temp Rise °F	SCFM	Temp Rise °F
FPG33N9024D*	T1	45.0	35-65	392		339		305		273		241	
	T2		35-65	377		339		305		273		241	
	T3 <sup>H</sup>		35-65	722	40	684	42	650	45	618	47	586	50
	T4 <sup>C</sup>		35-65	863	34	825	35	791	37	758	38	726	40
	T5		35-65	1008	29	971	30	937	31	904	32	872	33
FPG44N9024D*	T1	45.0	30-60	405		373		338		304		271	
	T2		30-60	405		373		338		304		271	
	T3 <sup>H</sup>		30-60	912	42	880	44	845	45	810	47	778	49
	T4 <sup>C</sup>		30-60	863	44	831	46	796	48	761	50	728	53
	T5		30-60	1012	38	980	39	945	41	910	42	877	44
FPG55N9024D*	T1	50.0	30-60	404		375		342		310		279	
	T2		30-60	404		375		342		310		279	
	T3 <sup>H</sup>		30-60	1040	46	1011	47	978	48	946	50	915	52
	T4 <sup>C</sup>		30-60	863	55	834	57	801	59	768	62	738	64
	T5		30-60	1013	47	985	48	952	50	919	52	889	53
FPG44N9030D*	T1	45.0	35-65	649	59	617	62	582		547		515	
	T2		35-65	649	59	617	62	582		547		515	
	T3 <sup>H</sup>		35-65	912	42	880	44	845	45	810	47	778	49
	T4 <sup>C</sup>		35-65	797	48	765	50	730	52	695	55	663	58
	T5		35-65	991	39	959	40	924	41	889	43	857	45
FPG55N9030D*	T1	50.0	35-65	646		617		584		552		521	
	T2		35-65	646		617		584		552		521	
	T3 <sup>H</sup>		35-65	1040	46	1011	47	978	48	946	50	915	52
	T4 <sup>C</sup>		35-65	788	60	759	62	727		694		663	
	T5		35-65	988	48	959	49	926	51	893	53	863	55

Airflow data shown is with dry coil at 70°F DB EAT with standard 1" air filter.

For models with five speed taps, tap T1 is for ventilation. T3 is for heating operation. T2 is for freeze protection. T4-T5 is for cooling operation. Superscript <sup>C</sup> indicates factory-set default cooling tap. Superscript <sup>H</sup> indicates factory-set default heating tap.

Data is subject to change. Please verify current information on [www.firstco.com](http://www.firstco.com).





FIRST CO.

P.O. BOX 270969 - DALLAS, TEXAS 75227

PH. (214) 388-5751 | FAX (214) 388-2255

MAY 2024