

First Co.

FIRST-PAK[™]

AC



*Space Constrained Package Air Conditioner
with Electric Heat*

12,000 through 30,000 BTUH Cooling Capacity

5KW - 15KW Electric Heat

11.7 SEER 2

R454B



NOMENCLATURE

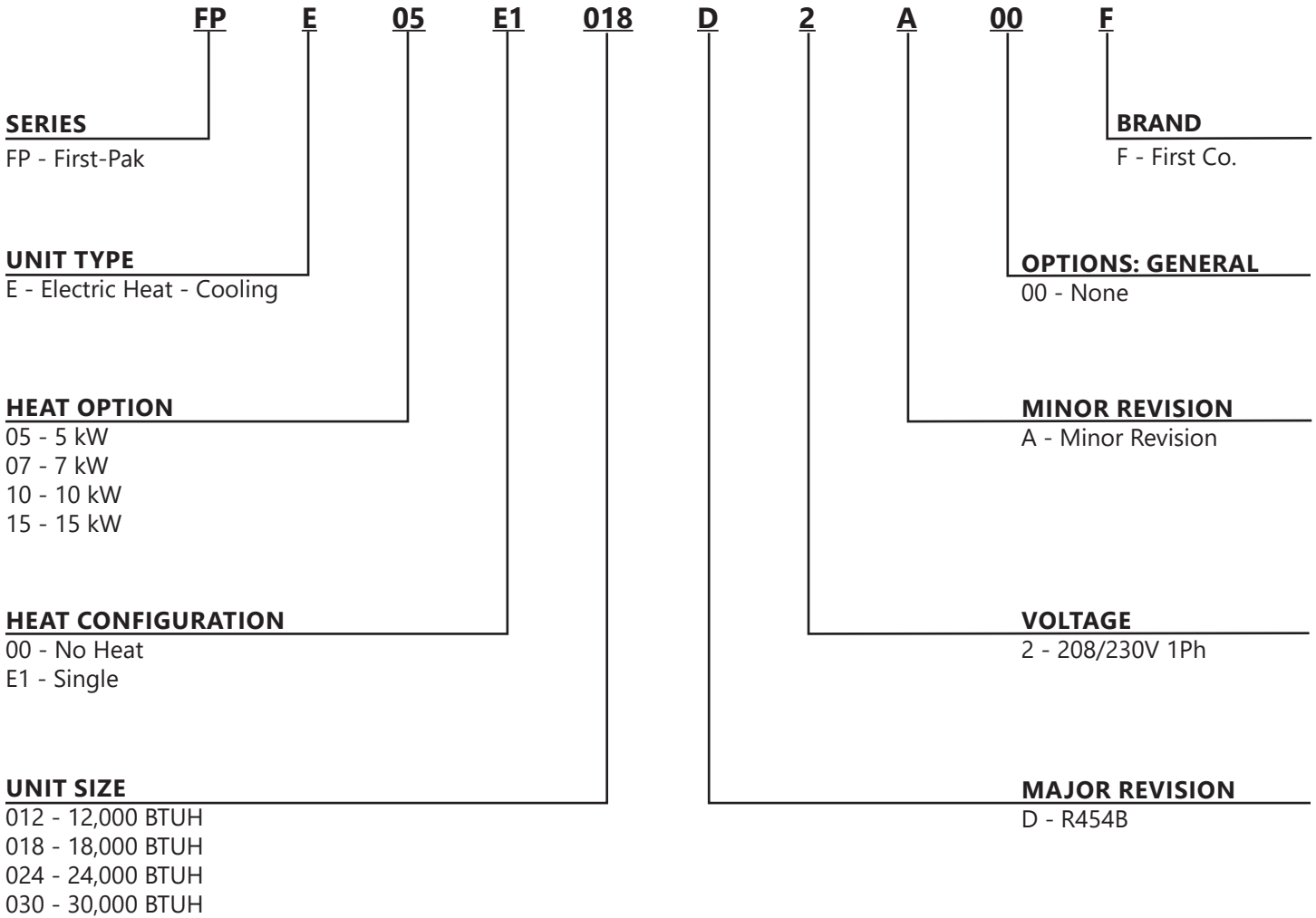

FIRST-PAK AC

SPACE CONSTRAINED PACKAGE AIR CONDITIONER

PRODUCT DESCRIPTION

- Self-contained packaged units with electric cooling and electric heating.
- Pre-wired and pre-charged with R-454B refrigerant.
- Eliminates the need for outdoor condensers, electrical, refrigerant piping, and external venting.
- All FPE series units are compatible with Magic-Pak, Comfort-Pack and Condo-Pack.

PRODUCT FEATURES

- High efficiency scroll and rotary compressors
- Easily accessible refrigeration service ports with an area for temperature probes.
- Factory installed condensate float switch.
- Architectural louvers available.
- Larger air coil with low face velocity for improved cooling performance.
- High efficiency ECM indoor blower with multiple speed taps for precise airflow selection.
- High efficiency ECM condenser fan motor to improve system efficiency.
- Insulation inside of cooling compartment to improve cooling performance and reduce noise
- Dual inlet indoor blower to lower fan RPM's, improve efficiency and reduce noise
- Double isolated compressor mount to lower compressor noise and vibration
- Blower collar locking mechanism to improve seal between cooling chassis and cabinet

SERVICEABILITY FEATURES

- Slide out cooling chassis for ease of service.
- Easy access or removal of electric heaters.
- High efficiency TXV on all models to allow for field adjustments, if required.
- All electrical components are serviceable from front of the unit.
- Compressor capacitor, compressor contactor, and indoor fan control located on panel at the front of the unit.
- Additional cooling chassis can be stocked and switched out to limit down time of the occupant.
- Refrigerant service ports are located on the outside the cooling chassis.
- Refrigerant leak mitigation on units over 4lbs of charge

LIMITED WARRANTY

5 year limited warranty on parts and compressor.

FIRST-PAK AC

SPACE CONSTRAINED PACKAGE AIR CONDITIONER

FEATURES AND BENEFITS

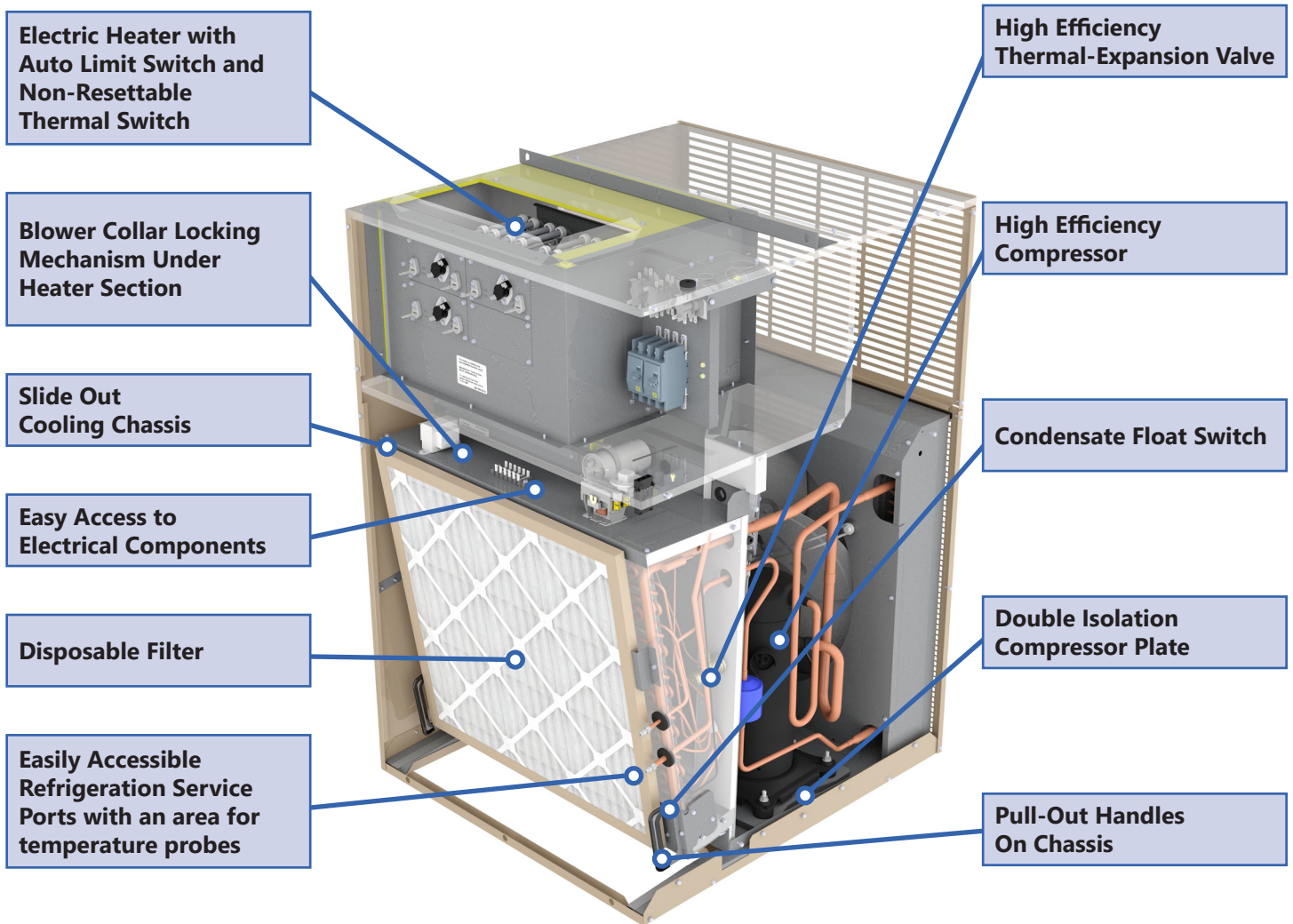

FIRST-PAK AC

SPACE CONSTRAINED PACKAGE AIR CONDITIONER

ACCESSORIES WALL SLEEVES

- Part number 929-10
- Ships unassembled in carton

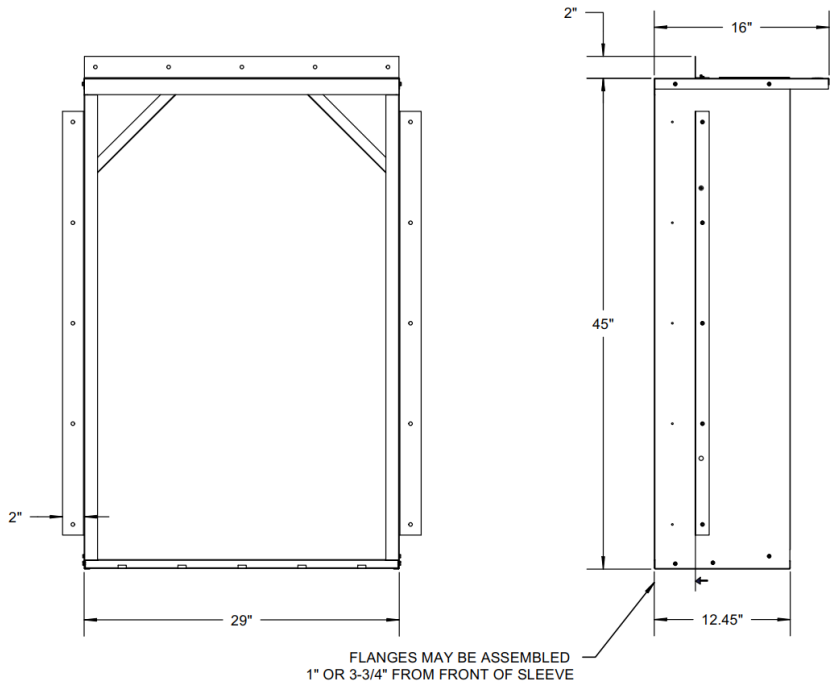

ALUMINUM ARCHITECTURAL LOUVERS (OPTIONAL)

- Part number G230A Clear Anodized Finish
- Part number G230S* Custom Painted Finish

STANDARD PAINT COLORS

*ASCOT WHITE (19)	*LIGHT STONE (43)	*SHELBURNE (69)
*BONE WHITE (24)	*PORTLAND STONE (49)	*MEDIUM BRONZE (72)
*CORONADO RED (34)	*TAUPE (52)	*DARK BRONZE (75)
*FOREST GREEN (36)	*SAHARA TAN (65)	*STONE GRAY (78)
*HERRINGBONE (37)	*SANDSTONE (67)	*BLACK (89)

*Custom Color with paint matching.

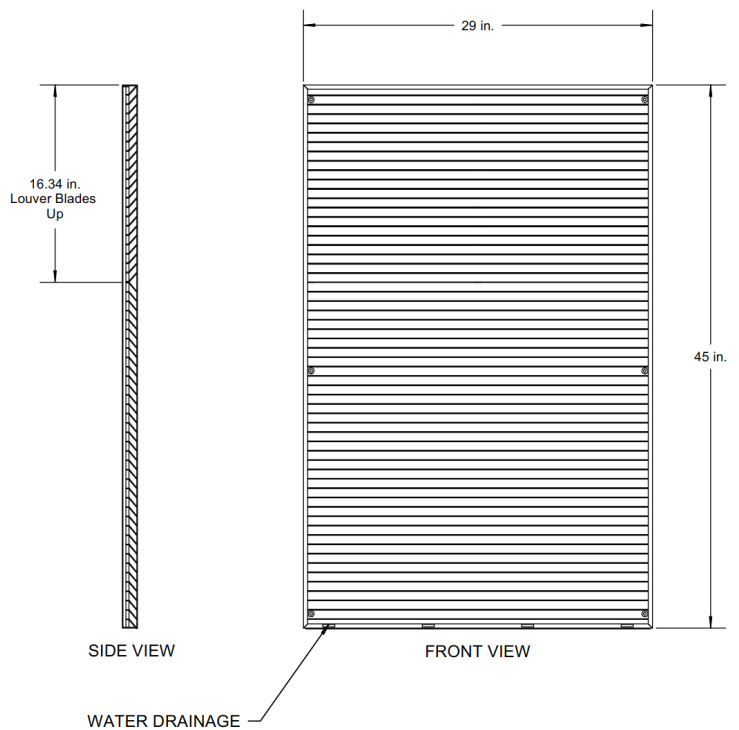

FIRST-PAK AC

SPACE CONSTRAINED PACKAGE AIR CONDITIONER

PHYSICAL DATA

FPE MODELS	FPE05E1012D	FPE07E1012D	FPE10E1012D	FPE05E1018D	FPE07E1018D	FPE10E1018D	FPE05E1024D
Unit Information							
Quantity / Type	Rotary (1)	Rotary (1)	Rotary (1)	Rotary (1)	Rotary (1)	Rotary (1)	Scroll (1)
Factory Charge (R454B) lbs. [kg]	4.8 [2.18]	4.8 [2.18]	4.8 [2.18]	4.5 [2.04]	4.5 [2.04]	4.5 [2.04]	4.8 [2.18]
Compressor Capacitor	35/370	35/370	35/370	35/370	35/370	35/370	35/370
Condenser Fan HP [kW]	1/5 [.15]	1/5 [.15]	1/5 [.15]	1/5 [.15]	1/5 [.15]	1/5 [.15]	1/3 [.25]
Indoor Fan HP [kW]	1/4 [.17]	1/4 [.17]	1/4 [.17]	1/3 [.25]	1/3 [.25]	1/3 [.25]	1/2 [.37]
Blower Size (D X W) in. [mm]	10 x 6 [25.4 x 15.24]						
Condenser Dimension (H x W) in. [mm]	26.5 x 22.25 [67.3 x 56.5]						
Evaporator Dimension (H x W) in. [mm]	23.1 x 22.25 [58.8 x 56.5]						
Filter Size (H x W) [mm]	24 x 24 [60.96 x 60.96]						
Electric Heater [kW] @240V	5	7(2x3.5kW)	10(2x5kW)	5	7(2x3.5kW)	10(2x5kW)	5(1x5kW)
Max. Static Pressure IWC [pa]	0.5 [125]						
Operating Weight lb. [kg]	280 [127]	280 [127]	280 [127]	330 [149.7]	330 [149.7]	330 [149.7]	350 [158.8]
Shipping Weight lb. [kg]	300 [136.1]	300 [136.1]	300 [136.1]	350 [158.8]	350 [158.8]	350 [158.8]	370 [167.8]

FPE MODELS	FPE07E1024D	FPE10E1024D	FPE15E1024D	FPE05E1030D	FPE07E1030D	FPE10E1030D	FPE15E1030D
Unit Information							
Quantity/Type	Scroll (1)	Scroll (1)	Scroll (1)	Scroll (1)	Scroll (1)	Scroll (1)	Scroll (1)
Factory Charge (R454B) lbs. [kg]	4.8 [2.18]	4.8 [2.18]	4.8 [2.18]	4 [1.81]	4 [1.81]	4 [1.81]	4 [1.81]
Compressor Capacitor	35/370	35/370	35/370	40/370	40/370	40/370	40/370
Condenser Fan HP [kW]	1/3 [.25]	1/3 [.25]	1/3 [.25]	1/3 [.25]	1/3 [.25]	1/3 [.25]	1/3 [.25]
Indoor Fan HP [kW]	1/2 [.37]	1/2 [.37]	1/2 [.37]	1/2 [.37]	1/2 [.37]	1/2 [.37]	1/2 [.37]
Blower Size (D X W) in. [mm]	10 x 6 [25.4 x 15.24]						
Condenser Dimension (H x W) in. [mm]	26.5 x 22.25 [67.3 x 56.5]						
Evaporator Dimension (H x W) in. [mm]	23.1 x 22.25 [58.8 x 56.5]						
Filter Size (H x W) in. [mm]	24 x 24 [60.96 x 60.96]						
Electric Heater [kW] @240V	7(2x3.5kW)	10(2x5kW)	15(3x5kW)	5(1x5kW)	7(2x3.5kW)	10(2x5kW)	7(2x3.5kW)
Max. Static Pressure IWC [pa]	0.5 [125]						
Operating Weight lb. [kg]	350 [158.8]	350 [158.8]	350 [158.8]	350 [158.8]	350 [158.8]	350 [158]	350 [159]
Shipping Weight lb. [kg]	370 [167.8]	370 [167.8]	370 [167.8]	370 [167.8]	370 [167.8]	370 [167.8]	370 [167.8]

Data is subject to change. Please verify most current information on www.firstco.com.

FIRST-PAK AC

SPACE CONSTRAINED PACKAGE AIR CONDITIONER

PHYSICAL DATA UNIT DIMENSIONS

TOP VIEW:
5KW - 10 KW
CABINET WITH SINGLE
POWER INPUT

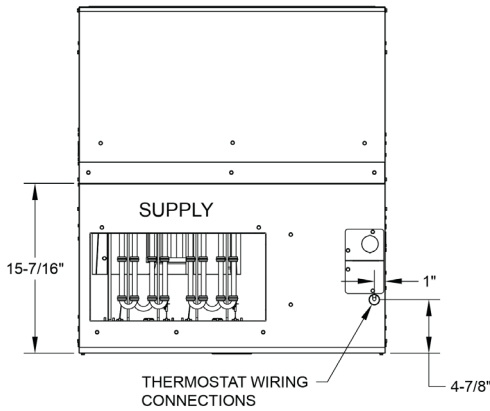

TOP VIEW
15KW
CABINET WITH TWO
POWER INPUT

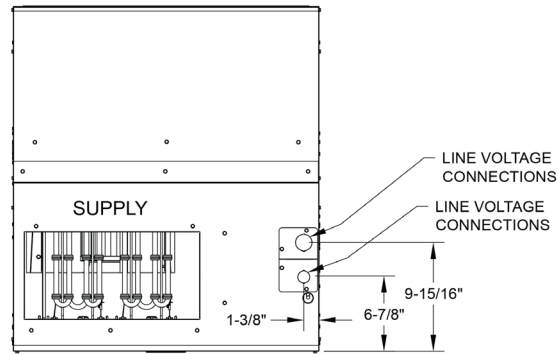

REAR VIEW

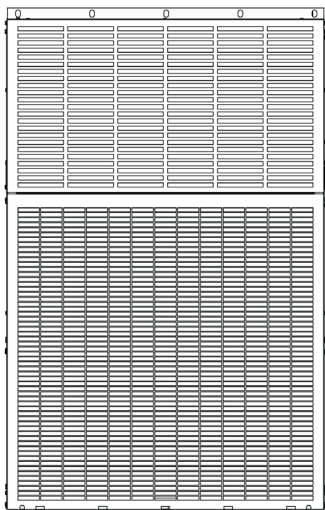

FRONT VIEW

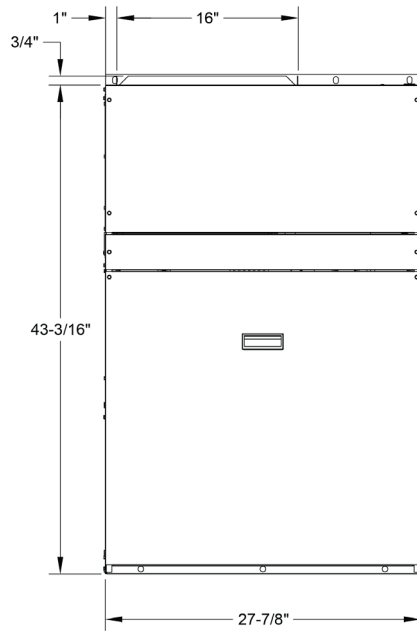

SIDE VIEW

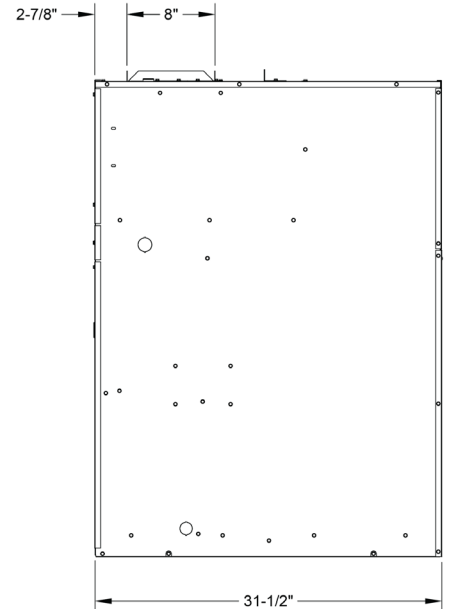

BOTTOM VIEW

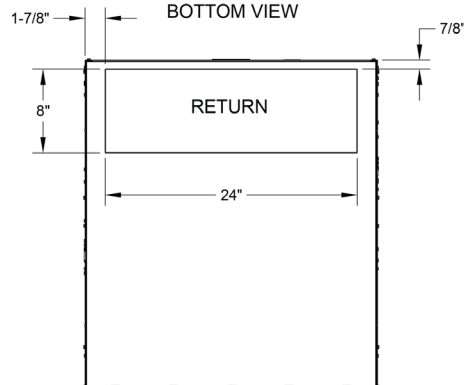

FIRST-PAK AC

SPACE CONSTRAINED PACKAGE AIR CONDITIONER

ELECTRIC HEAT DATA

UNIT MODEL	VOLTAGE - PHASE	ELECTRIC HEATER				
		KW		AUTO-RESET LIMIT SWITCH	NONRESETTABLE FUSE LINK	MIN. AIRFLOW (SCFM)
		240V	208V			
FPE05E1012D	230/208V - 1Ph	5	3.75	160°F	104°C	408
FPE07E1012D	230/208V - 1Ph	7	5.25	160°F	145°C	500
FPE10E1012D	230/208V - 1Ph	10	7.5	160°F	104°C	557
FPE05E1018D	230/208V - 1Ph	5	3.75	160°F	104°C	500
FPE07E1018D	230/208V - 1Ph	7	5.25	160°F	145°C	637
FPE10E1018D	230/208V - 1Ph	10	7.5	160°F	145°C	750
FPE05E1024D	230/208V - 1Ph	5	3.75	160°F	104°C	525
FPE07E1024D	230/208V - 1Ph	7	5.25	160°F	145°C	700
FPE10E1024D	230/208V - 1Ph	10	7.5	160°F	145°C	760
FPE15E1024D	230/208V - 1Ph	15	11.3	160°F	145°C	1070
FPE05E1030D	230/208V - 1Ph	5	3.75	160°F	104°C	674
FPE07E1030D	230/208V - 1Ph	7	5.25	160°F	145°C	664
FPE10E1030D	230/208V - 1Ph	10	7.5	160°F	145°C	705
FPE15E1030D	230/208V - 1Ph	15	11.3	160°F	145°C	823

For all models, units have single point power and can only operate either the compressor or electric heat, not both simultaneously. Refer to the wiring diagrams in the EFE IOM for additional details.

Wire size should be determined in accordance with National Electric Codes.

Unit are rated for 208/230V, but MOP, MCA values are calculated at 208/240V

FIRST-PAK AC

SPACE CONSTRAINED PACKAGE AIR CONDITIONER

ELECTRICAL AND PERFORMANCE DATA

ELECTRICAL DATA															
MODEL NUMBER	VOLTAGE PH-HZ	COMPRESSOR		CONDENSOR MOTOR		INDOOR MOTOR		MIN. CIRCUIT AMPACITY				MAX. CIRCUIT PROTECTION			
		RLA	LRA	FLA	HP	FLA	HP	CKT1		CKT2		CKT1		CKT2	
								240V	208V	240V	208V	240V	208V	240V	208V
FPE05E1012D	208/230-1-60	4.6	25	2.8	1/3	2.3	1/4	29	25	0	0	30	30	0	0
FPE07E1012D	208/230-1-60	4.6	25	2.8	1/3	2.3	1/4	39	34	0	0	40	35	0	0
FPE10E1012D	208/230-1-60	4.6	25	2.8	1/3	2.3	1/4	55	48	0	0	60	50	0	0
FPE05E1018D	208/230-1-60	7.2	47	2.8	1/3	2.8	1/3	30	26	0	0	30	30	0	0
FPE07E1018D	208/230-1-60	7.2	47	2.8	1/3	2.8	1/3	40	35	0	0	40	40	0	0
FPE10E1018D	208/230-1-60	7.2	47	2.8	1/3	2.8	1/3	56	49	0	0	60	50	0	0
FPE05E1024D	208/230-1-60	10.2	58	2.8	1/3	4.1	1/2	31	28	0	0	35	30	0	0
FPE07E1024D	208/230-1-60	10.2	58	2.8	1/3	4.1	1/2	42	37	0	0	45	40	0	0
FPE10E1024D	208/230-1-60	10.2	58	2.8	1/3	4.1	1/2	57	50	0	0	60	60	0	0
FPE15E1024D	208/230-1-60	10.2	58	2.8	1/3	4.1	1/2	57	50	26	23	60	60	30	25
FPE05E1030D	208/230-1-60	12.8	77	2.8	1/3	4.1	1/2	31	28	0	0	35	35	0	0
FPE07E1030D	208/230-1-60	12.8	77	2.8	1/3	4.1	1/2	42	37	0	0	45	40	0	0
FPE10E1030D	208/230-1-60	12.8	77	2.8	1/3	4.1	1/2	57	50	0	0	60	60	0	0
FPE15E1030D	208/230-1-60	12.8	77	2.8	1/3	4.1	1/2	57	50	26	23	60	60	30	25

FPE AHRI DATA										
MODEL NUMBER	COOLING						HEATING			
	Btu/hr	EER	SEER	S/T	Full Load CFM	CFM Part Load	240V		208V	
							KW	Btu/Hr	KW	Btu/Hr
FPE05E1012D	11000	10.5	11.7	0.85	450	-	05	17060	3.75	12796
FPE07E1012D							07	23885	5.25	17914
FPE10E1012D							10	34121	7.5	25591
FPE05E1018D	16500	10.5	11.7	0.78	650	-	05	17061	3.75	12796
FPE07E1018D							07	23885	5.25	17941
FPE10E1018D							10	34121	7.5	25591
FPE05E1024D	21400	10	11.7	0.78	800	-	05	17061	3.75	12796
FPE07E1024D							07	23885	5.25	17914
FPE10E1024D							10	34121	7.5	25591
FPE15E1024D							15	51182	11.25	38387
FPE05E1030D	25600	9	11.7	0.73	950	700	05	17061	3.75	12796
FPE07E1030D							07	23885	5.25	17914
FPE10E1030D							10	34121	7.5	25591
FPE15E1030D							15	51182	11.25	38387

All units tested to AHRI 210/240 2020 (SEER2)

Data is subject to change. Please verify most current information on www.firstco.com.

FIRST-PAK AC

SPACE CONSTRAINED PACKAGE AIR CONDITIONER

EXTENDED PERFORMANCE DATA

Model Number	Indoor Temp DB/ WB	Outdoor Temperature °F																	
		65.0			75.0			85.0			95.0			105.0			115.0		
		MBTUH	S/T	W	MBTUH	S/T	W	MBTUH	S/T	W	MBTUH	S/T	W	MBTUH	S/T	W	MBTUH	S/T	W
FPE**E1012D	75/57	11200	1.0	0.8	10700	1.0	0.8	10200	1.0	0.9	9800	1.0	1.1	9300	1.0	1.2	8800	1.0	1.3
	75/63	12200	0.8	0.8	11500	0.8	0.8	10900	0.9	0.9	10300	0.9	1.1	9600	0.9	1.2	9000	0.9	1.3
	80/67	13000	0.8	0.8	12300	0.8	0.8	11700	0.8	0.9	11000	0.9	1.1	10400	0.9	1.2	9700	0.9	1.3
	85/72	14100	0.7	0.7	13400	0.7	0.8	12700	0.8	0.9	11900	0.8	1.1	11200	0.8	1.2	10500	0.8	1.3
FPE**E1018D	75/57	16900	1.0	1.1	16100	1.0	1.3	15000	1.0	1.4	14300	1.0	1.6	13700	1.0	1.8	13000	1.0	2.0
	75/63	18200	0.8	1.1	17300	0.8	1.3	16400	0.8	1.4	15500	0.8	1.6	14600	0.8	1.8	13800	0.9	2.0
	80/67	19400	0.7	1.1	18500	0.7	1.3	17600	0.8	1.4	16600	0.8	1.6	15700	0.8	1.8	14700	0.8	2.0
	85/72	21100	0.7	1.1	20100	0.7	1.3	19100	0.7	1.4	18100	0.7	1.6	17100	0.7	1.8	16000	0.8	2.0
FPE**E1024D	75/57	21900	1.0	1.5	21100	1.0	1.7	19600	1.0	1.9	18700	1.0	2.1	17800	1.0	2.3	16900	1.0	2.5
	75/63	23600	0.8	1.5	22500	0.8	1.7	21300	0.8	1.9	20100	0.8	2.1	19000	0.8	2.3	17900	0.9	2.5
	80/67	25200	0.7	1.5	24000	0.8	1.7	22800	0.8	1.9	21500	0.8	2.1	20300	0.8	2.3	19200	0.8	2.5
	85/72	27300	0.7	1.5	26000	0.7	1.7	24800	0.7	1.9	23500	0.8	2.1	22000	0.7	2.3	20700	0.8	2.5
FPE**E1030D	75/57	25600	1.0	2.1	24500	1.0	2.3	23600	1.0	2.5	22800	1.0	2.7	21300	1.0	2.9	20300	1.0	3.2
	75/63	28200	0.7	2.1	26900	0.7	2.3	25700	0.7	2.5	24400	0.8	2.7	23000	0.8	2.9	21800	0.8	3.2
	80/67	30000	0.7	2.2	28700	0.7	2.3	27300	0.7	2.5	25900	0.7	2.7	24600	0.8	2.9	23200	0.8	3.2
	85/72	32500	0.6	2.2	31000	0.6	2.4	29400	0.6	2.5	27900	0.7	2.7	26500	0.7	2.9	25100	0.7	3.2

IMPORTANT: These extended capacities are based on the rated values of the combination as input by the user. These are reference values only. This information does not constitute a rating or a guarantee that the installed system will perform as indicated. Data is subject to change. Please verify most current information on www.firstco.com.

FIRST-PAK AC

SPACE CONSTRAINED PACKAGE AIR CONDITIONER

FAN AIR FORCE PERFORMANCE

MODEL	Motor Tap	Motor Speed	IWC STATIC PRESSURE									
			0.10		0.20		0.30		0.40		0.50	
			SCFM	W	SCFM	W	SCFM	W	SCFM	W	SCFM	W
FPE05E1012D*	1		405	32	365	36	326	39	290	43	259	46
	2	H1 ^H	553	63	514	67	475	70	439	74	408	77
	3	G ^C	527	57	487	60	448	64	412	68	382	71
	4	Y2	602	77	562	81	523	84	488	88	457	91
FPE07E1012D*	1		405	32	365	36	326	39	290	43	259	46
	2	H1 ^H	645	92	605	95	566	99	531	103	500	106
	3	G ^C	527	57	487	60	448	64	412	68	382	71
	4	Y2	602	77	562	81	523	84	488	88	457	91
FPE10E1012D*	1		405	32	365	36	326	39	290	43	259	46
	2	H1 ^H	702	115	663	118	624	122	588	126	557	129
	3	G ^C	527	57	487	60	448	64	412	68	382	71
	4	Y2	602	77	562	81	523	84	488	88	457	91
FPE05E1018D*	1		467	52	420	59	375	65	327	72	292	78
	2		769	132	722	139	678	145	629	152	595	158
	3	H1 ^H	675	100	628	107	583	113	535	121	500	127
	4	G ^C	724	116	677	123	632	128	584	136	549	142
	5	Y2	812	149	765	156	720	161	672	169	637	175
FPE07E1018D*	1		467	52	420	59	375	65	327	72	292	78
	2		769	132	722	139	678	145	629	152	595	158
	3	H1 ^H	812	149	765	156	720	161	672	169	637	175
	4	G ^C	724	116	677	123	632	128	584	136	549	142
	5	Y2	812	149	765	156	720	161	672	169	637	175
FPE10E1018D*	1		467	52	420	59	375	65	327	72	292	78
	2		769	132	722	139	678	145	629	152	595	158
	3	H1 ^H	924	204	877	211	832	217	783	225	749	230
	4	G ^C	724	116	677	123	632	128	584	136	549	142
	5	Y2	812	149	765	156	720	161	672	169	637	175

Airflow data shown is with dry coil at 70°F DB EAT with standard 1" air filter.

For models with five speed taps, tap T1 is for ventilation. T2 and T3 are for heating operation. T4 and T5 are for cooling operation.

Superscript C indicates factory-set default cooling tap. Superscript H indicates factory-set default heating tap.

Data is subject to change. Please verify most current information on www.firstco.com.

FIRST-PAK AC

SPACE CONSTRAINED PACKAGE AIR CONDITIONER

FAN AIR FLOW PERFORMANCE (CONT'D)

MODEL	Motor Tap	Motor Speed	IWC STATIC PRESSURE									
			0.10		0.20		0.30		0.40		0.50	
			SCFM	W	SCFM	W	SCFM	W	SCFM	W	SCFM	W
FPE05E1024D*	1		567	75	530	80	504	85	476	92	443	99
	2		783	142	746	146	720	152	692	159	658	165
	3	H1 ^H	650	96	613	101	587	107	559	114	525	120
	4	G ^C	888	195	851	200	825	206	797	213	763	219
	5	Y2	980	261	943	265	917	271	889	278	855	284
FPE07E1024D*	1		567	75	530	80	504	85	476	92	443	99
	2	H1 ^H	783	142	746	146	720	152	692	159	658	165
	3	H1 ^H	888	162	790	166	764	172	736	179	702	186
	4	G ^C	868	184	831	188	805	194	777	201	744	208
	5	Y2	980	261	943	265	917	271	889	278	855	284
FPE10E1024D*	1		567	75	530	80	504	85	476	92	443	99
	2		783	142	746	146	720	152	692	159	658	165
	3	H1 ^H	888	162	1161	476	1135	482	1107	489	1074	495
	4	G ^C	868	184	831	188	805	194	777	201	744	208
	5	Y2	980	261	943	265	917	271	889	278	855	284
FPE15E1024D*	1		567	75	530	80	504	85	476	92	443	99
	2		783	142	746	146	720	152	692	159	658	165
	3	H1 ^H	1198	472	1161	476	1135	482	1107	489	1074	495
	4	G ^C	868	184	831	188	805	194	777	201	744	208
	5	Y2	960	261	943	265	917	271	889	278	855	284
FPE05E1030D*	1		694	109	657	114	631	120	603	127	569	133
	2		838	167	801	172	775	177	747	184	713	191
	3	H1 ^H	650	67	613	101	587	107	559	114	525	120
	4	G ^C	962	247	925	251	899	257	871	264	837	270
	5	Y2	1103	372	1066	376	1040	382	1012	389	978	396
FPE07E1030D*	1		694	109	657	114	631	120	603	127	589	133
	2		838	167	801	172	775	177	747	184	713	191
	3	H1 ^H	783	142	746	146	720	152	692	159	658	165
	4	G ^C	962	247	925	251	899	257	871	264	837	270
	5	Y2	1103	372	1066	376	1040	382	1012	389	978	396

Airflow data shown is with dry coil at 70°F DB EAT with standard 1" air filter.

For models with five speed taps, tap T1 is for ventilation. T2 and T3 are for heating operation. T4 and T5 are for cooling operation.

Superscript C indicates factory-set default cooling tap. Superscript H indicates factory-set default heating tap.

Data is subject to change. Please verify most current information on www.firstco.com.

FIRST-PAK AC

SPACE CONSTRAINED PACKAGE AIR CONDITIONER

FAN AIR FLOW PERFORMANCE (CONT'D)

MODEL	Motor Tap	Motor Speed	IWC STATIC PRESSURE									
			0.10		0.20		0.30		0.40		0.50	
			SCFM	W	SCFM	W	SCFM	W	SCFM	W	SCFM	W
FPE10E1030D*	1		694	109	657	114	631	120	603	127	569	133
	2		838	167	801	172	775	177	747	184	713	191
	3	H ^H	888	195	851	200	825	206	797	213	763	219
	4	G ^C	962	247	925	251	899	257	871	264	837	270
	5	Y2	1103	372	1066	376	1040	382	1012	389	978	396
FPE15E1030D*	1		694	109	657	114	631	120	603	127	569	133
	2		838	167	801	172	77	177	747	184	713	191
	3	H ^H	1198	472	1160	476	1135	482	1107	489	1074	495
	4	G ^C	962	247	925	251	899	257	871	264	837	270
	5	Y2	1103	372	1066	376	1040	382	1012	389	978	396

Airflow data shown is with dry coil at 70°F DB EAT with standard 1" air filter.

For models with five speed taps, tap T1 is for ventilation. T2 and T3 are for heating operation. T4 and T5 are for cooling operation.

Superscript ^C indicates factory-set default cooling tap. Superscript ^H indicates factory-set default heating tap.

Data is subject to change. Please verify most current information on www.firstco.com.





AMERICAN-MADE. FAMILY OWNED.



FIRST CO.
P.O. BOX 270969 - DALLAS, TEXAS 75227
PH. (214) 388-5751 | FAX (214) 388-2255
WWW.FIRSTCO.COM

SEPTEMBER 2024