



# FIRST-PAK<sup>™</sup>

---

## AC



Single Package Vertical Air Conditioner  
*with Electric Heating*

12,000 through 30,000 BTUH  
Cooling Capacity



R454B

# Nomenclature

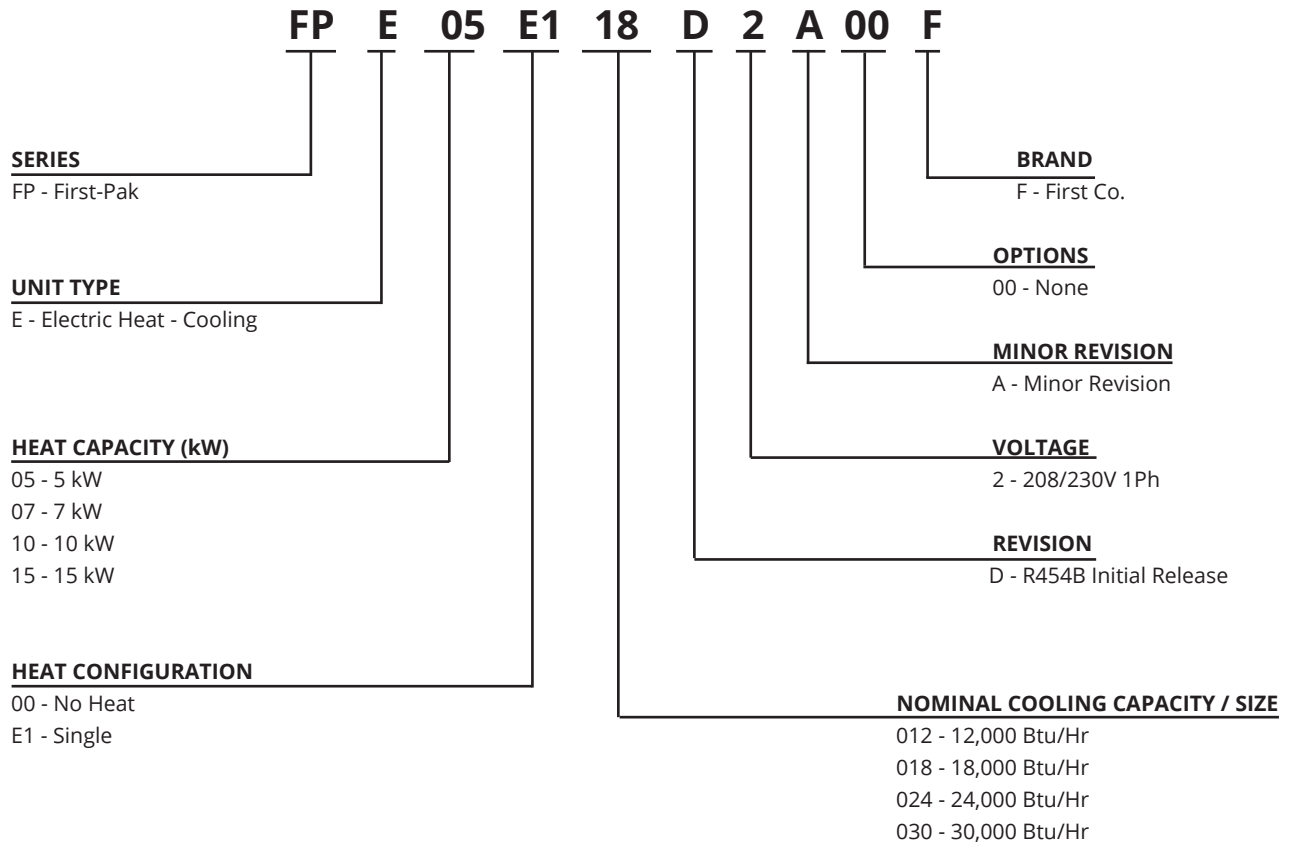

## PRODUCT DESCRIPTION

- Self-contained packaged units with electric cooling and electric heating
- Pre-wired and factory charged with R-454B refrigerant
- Eliminates the need for outdoor condensing section units, line-sets and separate ventilation
- All FPE series units are compatible with Magic-Pak, Comfort-Pack and Condo-Pack

## PRODUCT FEATURES

- High efficiency scroll and rotary compressors
- Easily accessible refrigeration service ports with an area for temperature probes
- Factory installed condensate float switch
- Architectural louvers available
- Larger air coil with low face velocity for improved cooling performance
- High efficiency ECM indoor blower with multiple speed taps for precise airflow selection
- High efficiency ECM condenser fan motor to improve system efficiency
- Insulation inside of cooling compartment to improve cooling performance and reduce noise
- Dual inlet indoor blower to lower fan RPMs, improve efficiency and reduce noise
- Double isolated compressor mount to reduce compressor noise and vibration
- Blower collar locking mechanism to improve seal between cooling chassis and cabinet

## SERVICEABILITY FEATURES

- Slide out cooling chassis for ease of service
- Easy access or removal of electric heaters
- High efficiency TXV on all models to allow for field adjustments, if required
- All electrical components are serviceable from front of the unit
- Compressor capacitor, compressor contactor, and indoor fan control located on panel at the front of the unit
- Additional cooling chassis can be stocked and switched out to limit down time of the occupant
- Refrigerant service ports are located on the outside of the cooling chassis.

## WARRANTY

- Five (5) years limited parts on compressor and all other covered components

## ACCESSORIES

- Wall Sleeves
- Architectural Louvers

# Features & Benefits

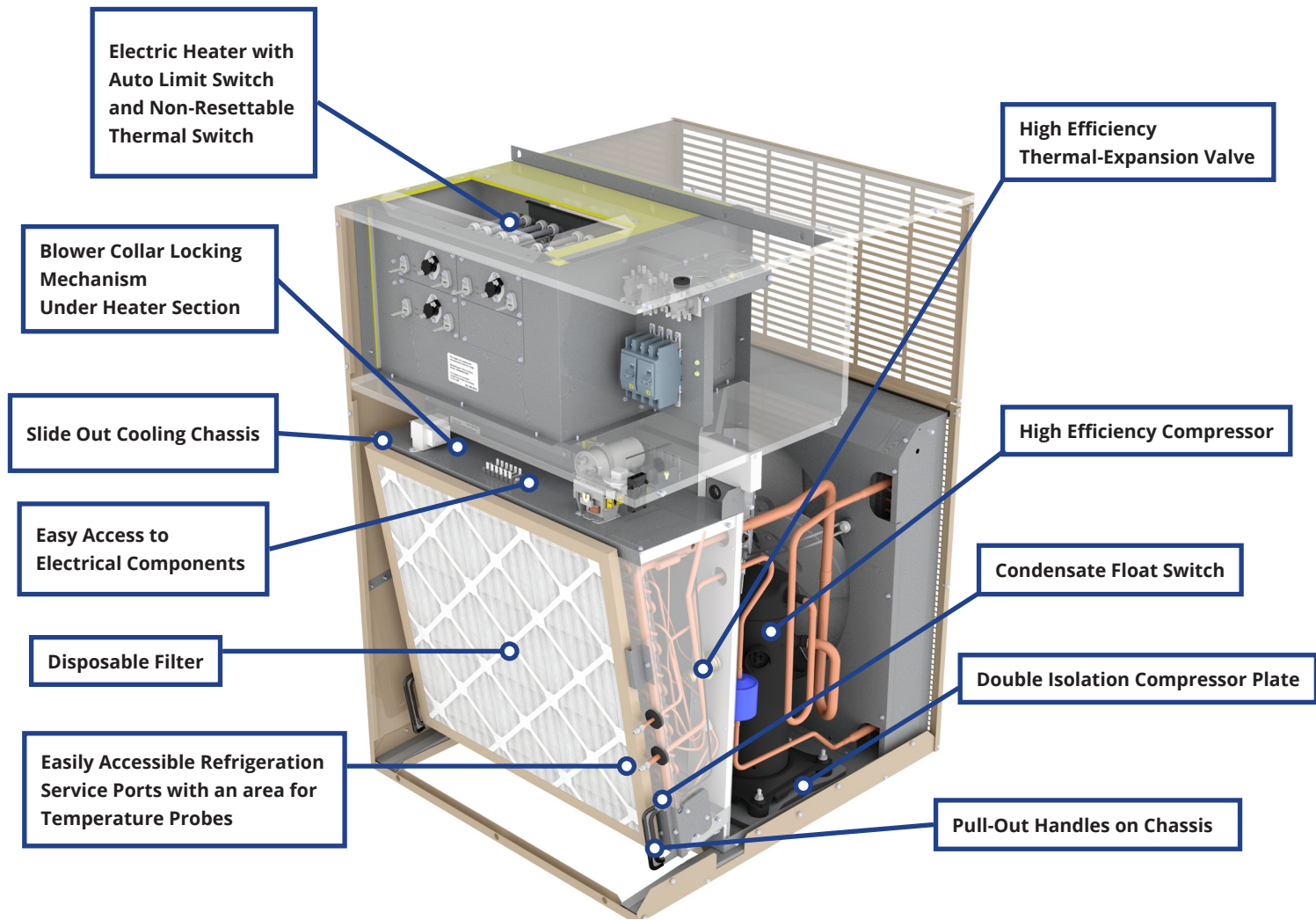

# Accessories

## WALL SLEEVES

- Part number 929-10
- Ships unassembled in carton

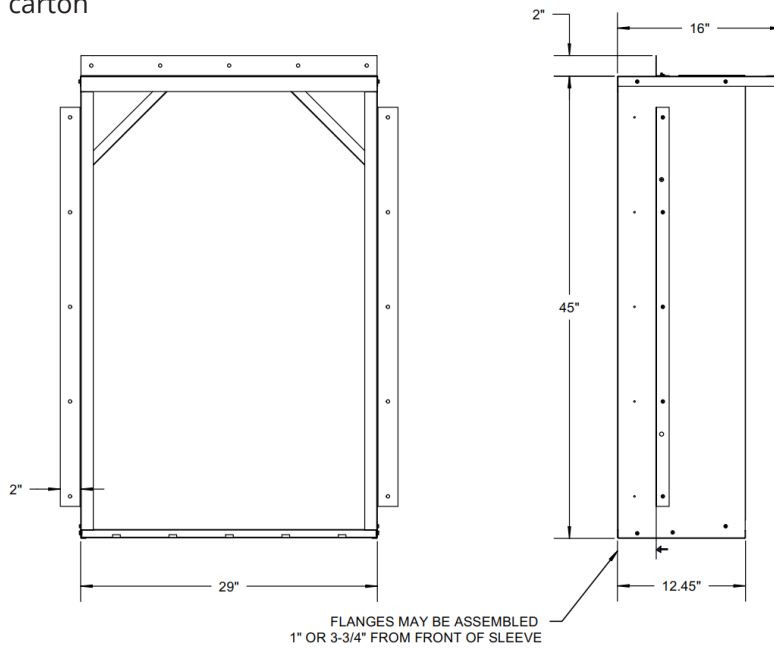

## ALUMINUM ARCHITECTURAL LOUVERS (OPTIONAL)

- Part number G230A Clear Anodized Finish
- Part number G230S\* Custom Painted Finish

### Standard Paint Colors

\*Custom Color with paint matching

 *ASCOT WHITE (19)	 *LIGHT STONE (43)	 *SHELBURNE (69)
 *BONE WHITE (24)	 *PORTLAND STONE (49)	 *MEDIUM BRONZE (72)
 *CORONADO RED (34)	 *TAUPE (52)	 *DARK BRONZE (75)
 *FOREST GREEN (36)	 *SAHARA TAN (65)	 *STONE GRAY (78)
 *HERRINGBONE (37)	 *SANDSTONE (67)	 *BLACK (89)

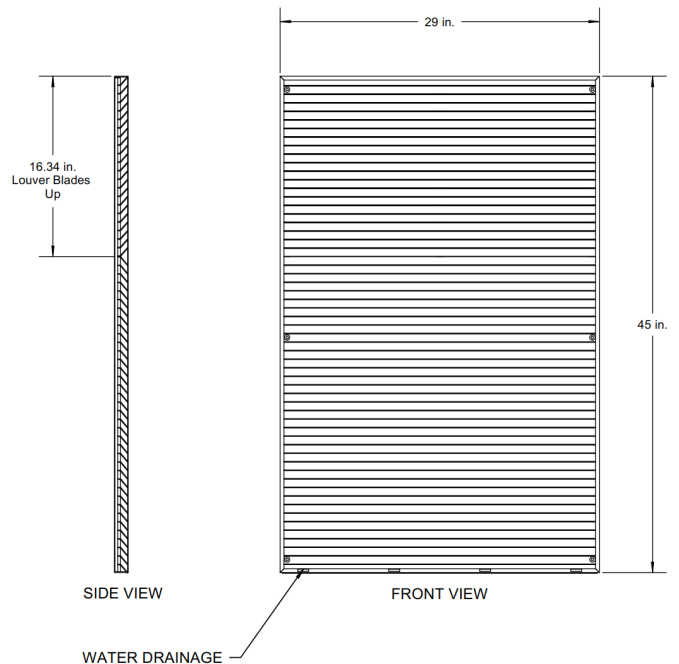

# Physical Data

FPE MODELS	FPE05E1012D	FPE07E1012D	FPE10E1012D	FPE05E1018D	FPE07E1018D	FPE10E1018D	FPE05E1024D
Unit Information							
Quantity / Type	Rotary (1)	Rotary (1)	Rotary (1)	Rotary (1)	Rotary (1)	Rotary (1)	Scroll (1)
Factory Charge (R454B) lbs. [kg]	3.75 [1.70]	3.75 [1.70]	3.75 [1.70]	4.8 [2.18]	4.8 [2.18]	4.8 [2.18]	4.9 [2.21]
Compressor Capacitor	35MFD/370V	35MFD/370V	35MFD/370V	40MFD/370V	40MFD/370V	40MFD/370V	35MFD/370V
Condenser Fan HP [kW]	1/5 [.15]	1/5 [.15]	1/5 [.15]	1/3 [.25]	1/3 [.25]	1/3 [.25]	1/3 [.25]
Indoor Fan HP [kW]	1/4 [.17]	1/4 [.17]	1/4 [.17]	1/3 [.25]	1/3 [.25]	1/3 [.25]	1/2 [.37]
Blower Size (D X W) in. [mm]	10 x 6 [25.4 x 15.24]						
Condenser Dimension (H x W) in. [mm]	26.5 x 22.25 [67.3 x 56.5]						
Evaporator Dimension (H x W) in. [mm]	23.1 x 22.25 [58.7 x 56.5]						
Filter Size (H x W) [mm]	24 x 24 [60.96 x 60.96]						
Electric Heater [kW] @240V	5kW	7(2x3.5kW)	10(2x5kW)	5kW	7(2x3.5kW)	10(2x5kW)	5(1x5kW)
Max. Static Pressure IWC [pa]	.5" [125]						
Operating Weight lb. [kg]	273 [124]	275 [125]	275 [125]	327 [149]	329 [150]	329 [150]	345 [157]
Shipping Weight lb. [kg]	293 [133]	295 [134]	295 [134]	347 [159]	349 [159]	349 [159]	365 [166]

FPE MODELS	FPE07E1024D	FPE10E1024D	FPE15E1024D	FPE05E1030D	FPE07E1030D	FPE10E1030D	FPE15E1030D
Unit Information							
Quantity / Type	Scroll (1)	Scroll (1)	Scroll (1)	Scroll (1)	Scroll (1)	Scroll (1)	Scroll (1)
Factory Charge (R454B) lbs. [kg]	4.9 [2.21]	4.9 [2.21]	4.9 [2.21]	5.0 [2.27]	5.0 [2.27]	5.0 [2.27]	5.0 [2.27]
Compressor Capacitor	35MFD/370V	35MFD/370V	35MFD/370V	40MFD/370V	40MFD/370V	40MFD/370V	40MFD/370V
Condenser Fan HP [kW]	1/3 [.25]	1/3 [.25]	1/3 [.25]	1/3 [.25]	1/3 [.25]	1/3 [.25]	1/3 [.25]
Indoor Fan HP [kW]	1/2 [.37]	1/2 [.37]	1/2 [.37]	1/2 [.37]	1/2 [.37]	1/2 [.37]	1/2 [.37]
Blower Size (D X W) in. [mm]	10 x 6 [25.4 x 15.24]						
Condenser Dimension (H x W) in. [mm]	26.5 x 22.25 [67.3 x 56.5]						
Evaporator Dimension (H x W) in. [mm]	23.1 x 22.25 [58.7 x 56.5]						
Filter Size (H x W) [mm]	24 x 24 [60.96 x 60.96]						
Electric Heater [kW] @240V	7(2x3.5kW)	10(2x5kW)	15(3x5kW)	5(1x5kW)	7(2x3.5kW)	10(2x5kW)	15(3x5kW)
Max. Static Pressure IWC [pa]	.5" [125]						
Operating Weight lb. [kg]	346 [157]	346 [157]	349 [158]	346 [157]	347 [158]	347 [158]	350 [159]
Shipping Weight lb. [kg]	366 [166]	366 [166]	369 [168]	366 [166]	367 [167]	367 [167]	370 [168]

Data is subject to change. Please verify most current information on [www.firstco.com](http://www.firstco.com).

# Physical Data

## Unit Dimensions

TOP VIEW:  
5KW - 10 KW  
CABINET WITH SINGLE  
POWER INPUT

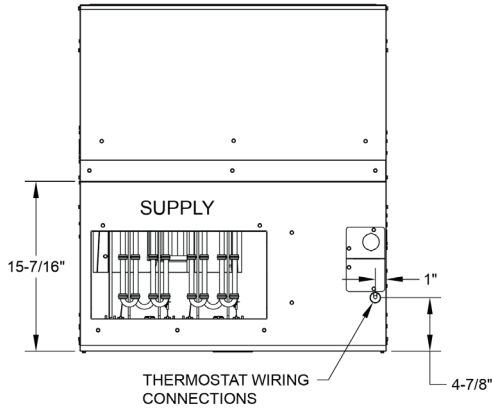

TOP VIEW  
15KW  
CABINET WITH TWO  
POWER INPUT

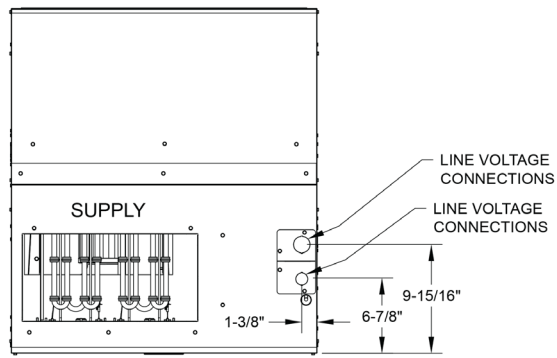

REAR VIEW

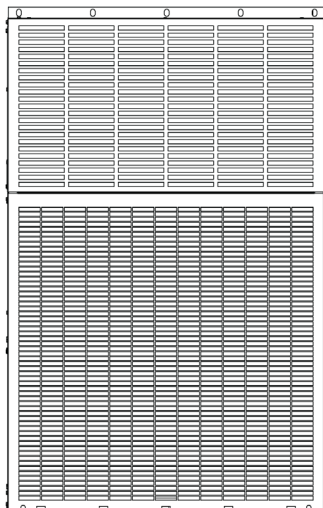

FRONT VIEW

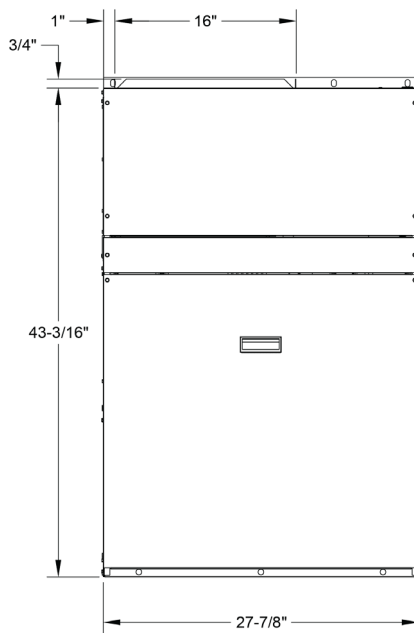

SIDE VIEW

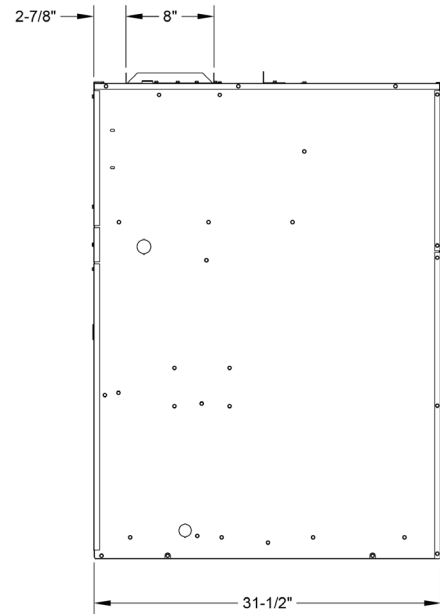

BOTTOM VIEW

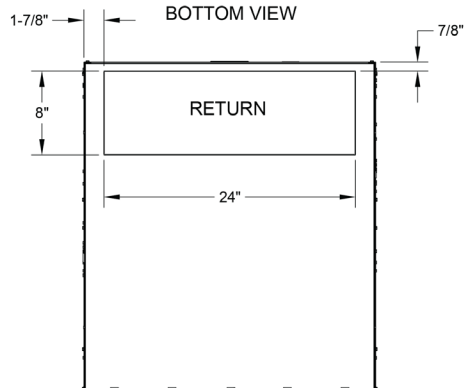

# Electric Heat Data

UNIT MODEL	VOLTAGE - PHASE	ELECTRIC HEATER				
		KW		AUTO-RESET LIMIT SWITCH	NONRESETTABLE FUSE LINK	MIN. AIRFLOW (SCFM)
		240V	208V			
FPE05E1012D	230/208V - 1Ph	5	3.76	160°F	104°C	386
FPE07E1012D	230/208V - 1Ph	7	5.26	160°F	104°C	488
FPE10E1012D	230/208V - 1Ph	10	7.5	160°F	104°C	488
FPE05E1018D	230/208V - 1Ph	5	3.76	160°F	104°C	639
FPE07E1018D	230/208V - 1Ph	7	5.26	160°F	104°C	639
FPE10E1018D	230/208V - 1Ph	10	7.5	160°F	104°C	709
FPE05E1024D	230/208V - 1Ph	5	3.76	160°F	104°C	674
FPE07E1024D	230/208V - 1Ph	7	5.26	160°F	104°C	664
FPE10E1024D	230/208V - 1Ph	10	7.5	160°F	104°C	705
FPE15E1024D	230/208V - 1Ph	15	11.3	160°F	104°C	823
FPE05E1030D	230/208V - 1Ph	5	3.76	160°F	104°C	674
FPE07E1030D	230/208V - 1Ph	7	5.26	160°F	104°C	664
FPE10E1030D	230/208V - 1Ph	10	7.5	160°F	104°C	705
FPE15E1030D	230/208V - 1Ph	15	11.3	160°F	104°C	823

Data is subject to change. Please verify most current information on [www.firstco.com](http://www.firstco.com).



# Electrical and Performance Data

ELECTRICAL DATA																	
MODEL NUMBER	VOLTAGE PH-HZ	COMPRES-SOR		CONDENSOR MOTOR		INDOOR MOTOR		MIN. CIRCUIT AMPACITY				MAX. CIRCUIT PROTECTION				MIN. VOLT.	MAX. VOLT.
		RLA	LRA	FLA	HP	FLA	HP	CKT1		CKT2		CKT1		CKT2			
								230V	208V	230V	208V	230V	208V	230V	208V		
FPE05E1012D	208/230-1-60	5.5	25	2.8	1/3	2.8	1/3	28.5	26.1	N/A	N/A	30	30	N/A	N/A	197	252
FPE07E1012D	208/230-1-60	5.5	25	2.8	1/3	2.8	1/3	38.4	35.1	N/A	N/A	40	40	N/A	N/A	197	252
FPE10E1012D	208/230-1-60	5.5	25	2.8	1/3	2.8	1/3	53.4	48.6	N/A	N/A	60	50	N/A	N/A	197	252
FPE05E1018D	208/230-1-60	7.6	35	2.8	1/3	2.8	1/3	28.5	26.1	N/A	N/A	30	30	N/A	N/A	197	252
FPE07E1018D	208/230-1-60	7.6	35	2.8	1/3	2.8	1/3	38.4	35.1	N/A	N/A	40	40	N/A	N/A	197	252
FPE10E1018D	208/230-1-60	7.6	35	2.8	1/3	2.8	1/3	53.4	48.6	N/A	N/A	60	50	N/A	N/A	197	252
FPE05E1024D	208/230-1-60	9.0	63	2.8	1/3	4.1	1/2	30.1	27.7	N/A	N/A	35	30	N/A	N/A	197	252
FPE07E1024D	208/230-1-60	9.0	63	2.8	1/3	4.1	1/2	40.1	36.7	N/A	N/A	45	40	N/A	N/A	197	252
FPE10E1024D	208/230-1-60	9.0	63	2.8	1/3	4.1	1/2	55.0	50.3	N/A	N/A	60	60	N/A	N/A	197	252
FPE15E1024D	208/230-1-60	9.0	63	2.8	1/3	4.1	1/2	55.0	50.3	25.0	22.6	60	60	25	25	197	252
FPE05E1030D	208/230-1-60	12.5	67	2.8	1/3	4.1	1/2	30.1	27.7	N/A	N/A	35	30	N/A	N/A	197	252
FPE07E1030D	208/230-1-60	12.5	67	2.8	1/3	4.1	1/2	40.1	36.7	N/A	N/A	45	40	N/A	N/A	197	252
FPE10E1030D	208/230-1-60	12.5	67	2.8	1/3	4.1	1/2	55.0	50.3	N/A	N/A	60	60	N/A	N/A	197	252
FPE15E1030D	208/230-1-60	12.5	67	2.8	1/3	4.1	1/2	55.0	50.3	25.0	22.6	60	60	25	25	197	252

FPE AHRI Data										
MODEL NUMBER	COOLING						HEATING			
	Btu/hr	EER	SEER	S/T	CFM Full Load CFM	CFM Part Load	240V		208V	
							KW	Btu/Hr	KW	Btu/Hr
FPE05E1012D	12500	10.5	11.7	0.75	450	-	5	17060	3.8	12814
FPE07E1012D							7	23884	5.3	17940
FPE10E1012D							10	34120	7.5	25628
FPE05E1018D	17000	10.0	11.7	0.78	630	-	5	17060	3.8	12814
FPE07E1018D							7	23884	5.3	17940
FPE10E1018D							10	34120	7.5	25628
FPE05E1024D	22500	10.0	11.7	0.74	780	-	5	17060	3.8	12814
FPE07E1024D							7	23884	5.3	17940
FPE10E1024D							10	34120	7.5	25628
FPE15E1024D							15	51180	11.3	38442
FPE05E1030D	26500	9.0	11.7	0.74	920	620	5	17060	3.8	12814
FPE07E1030D							7	23884	5.3	17940
FPE10E1030D							10	34120	7.5	25628
FPE15E1030D							15	51180	11.3	38442

Data is subject to change. Please verify most current information on [www.firstco.com](http://www.firstco.com).

# Extended Performance Data

Model Number	Indoor Temp DB/WB	Outdoor Temperature °F														
		65.0			85.0			95.0			105.0			115.0		
		MBH	S/T	kW	MBH	S/T	kW	MBH	S/T	kW	MBH	S/T	kW	MBH	S/T	kW
FPE**E1012D	75/57	13.2	1.0	0.9	12.1	1.0	1.1	12.1	1.0	1.2	11.0	1.0	1.3	10.4	1.0	1.4
	75/63	14.2	0.8	0.9	12.9	0.8	1.1	12.9	0.8	1.2	11.5	0.9	1.3	10.8	0.9	1.5
	80/67	15.2	0.8	0.9	13.8	0.8	1.1	13.8	0.8	1.2	12.3	0.9	1.3	11.6	0.9	1.5
	85/72	16.4	0.7	0.9	14.9	0.7	1.1	14.9	0.7	1.2	13.4	0.8	1.4	12.6	0.8	1.5
FPE**E1018D	75/57	18.4	1.0	1.2	16.8	1.0	1.4	15.9	1.0	1.5	15.0	1.0	1.6	14.1	1.0	1.8
	75/63	19.6	0.8	1.3	17.6	0.8	1.4	16.5	0.8	1.5	15.4	0.8	1.6	14.0	0.8	1.8
	80/67	20.7	0.7	1.3	18.6	0.8	1.4	17.5	0.8	1.6	16.2	0.8	1.7	14.2	1.0	1.8
	85/72	22.2	0.7	1.3	20.0	0.7	1.5	19.0	0.8	1.6	17.3	0.7	1.7	15.6	0.7	1.8
FPE**E1024D	75/57	23.9	1.0	1.7	21.4	1.0	2.0	20.4	1.0	2.2	19.3	1.0	2.4	18.3	1.0	2.7
	75/63	25.7	0.8	1.7	23.2	0.8	2.0	21.9	0.8	2.2	20.7	0.8	2.4	19.4	0.9	2.7
	80/67	27.5	0.7	1.7	24.8	0.8	2.0	23.5	0.8	2.2	22.2	0.8	2.5	20.8	0.8	2.7
	85/72	29.7	0.7	1.7	26.9	0.7	2.0	25.5	0.7	2.3	24.1	0.7	2.5	22.6	0.8	2.7
FPE**E1030D	75/57	27.5	1.0	2.2	25.2	1.0	2.5	24.0	1.0	2.8	22.7	1.0	3.0	21.5	1.0	3.3
	75/63	30.1	0.7	2.2	27.1	0.8	2.5	25.6	0.8	2.8	24.0	0.8	3.0	22.5	0.8	3.3
	80/67	31.6	0.7	2.2	28.4	0.8	2.5	26.9	0.8	2.8	25.2	0.8	3.1	23.6	0.9	3.4
	85/72	33.9	0.7	2.2	30.6	0.7	2.6	28.9	0.7	2.8	26.8	0.7	3.1	25.8	0.8	3.4

IMPORTANT: These extended capacities are based on the rated values of the combination as input by the user. These are reference values only. This information does not constitute a rating or a guarantee that the installed system will perform as indicated.

Data is subject to change. Please verify most current information on [www.firstco.com](http://www.firstco.com).

# Fan Air Flow Performance

Model Number	Blower Speed Tap	SCFM @ External Static Pressure (in.w.c)				
		0.1	0.2	0.3	0.4	0.5
FPE05E1012D	T1	328	307	285	265	246
	T2 <sup>H</sup>	544	522	501	480	462
	T3	632	611	589	569	551
	T4 <sup>C</sup>	508	487	466	445	427
	T5	578	557	535	515	496
FPE07E1012D	T1	328	307	285	265	246
	T2 <sup>H</sup>	611	590	568	548	529
	T3	694	672	651	630	612
	T4 <sup>C</sup>	508	487	466	445	427
	T5	578	557	535	515	496
FPE10E1012D	T1	328	307	285	265	246
	T2 <sup>H</sup>	694	672	651	630	612
	T3	611	590	568	548	529
	T4 <sup>C</sup>	508	487	466	445	427
	T5	578	557	535	515	496
FPE05E1018D	T1	460	438	417	396	378
	T2 <sup>H</sup>	751	730	708	688	669
	T3	869	848	826	806	788
	T4 <sup>C</sup>	674	652	631	611	592
	T5	760	739	717	697	678
FPE07E1018D	T1	460	438	417	396	378
	T2 <sup>H</sup>	751	730	708	688	669
	T3	869	848	826	806	788
	T4 <sup>C</sup>	674	652	631	611	592
	T5	760	739	717	697	678
FPE10E1018D	T1	460	438	417	396	378
	T2 <sup>H</sup>	928	907	885	865	847
	T3	804	783	761	741	722
	T4 <sup>C</sup>	674	652	631	611	592
	T5	760	739	717	697	678

•Airflow data shown is with dry coil at 70°F DB EAT with standard 1" air filter.

•For models with five speed taps, tap T1 is for ventilation. T2 and T3 are for heating operation. T4 and T5 are for cooling operation.

•Superscript C indicates factory-set default cooling tap. Superscript H indicates factory-set default heating tap.

Data is subject to change. Please verify most current information on [www.firstco.com](http://www.firstco.com).

# Fan Air Flow Performance

Continued

Unit Model	Blower Speed Tap	SCFM @ External Static Pressure (in.w.c)				
		0.1	0.2	0.3	0.4	0.5
FPE05E1024D	T1	544	522	501	480	462
	T2 <sup>H</sup>	804	783	761	741	722
	T3	975	954	932	912	894
	T4 <sup>C</sup>	846	824	803	782	764
	T5	969	948	926	906	887
FPE07E1024D	T1	544	522	501	480	462
	T2 <sup>H</sup>	804	783	761	741	722
	T3	975	954	932	912	894
	T4 <sup>C</sup>	846	824	803	782	764
	T5	969	948	926	906	887
FPE10E1024D	T1	544	522	501	480	462
	T2 <sup>H</sup>	846	824	803	782	764
	T3	975	954	932	912	894
	T4 <sup>C</sup>	846	824	803	782	764
	T5	969	948	926	906	887
FPE15E1024D	T1	545	517	484	452	421
	T2 <sup>H</sup>	1056	1027	995	962	931
	T3	938	909	877	844	813
	T4 <sup>C</sup>	870	841	809	777	745
	T5	970	941	909	876	845
FPE05E1030D	T1	687	658	626	593	562
	T2 <sup>H</sup>	822	793	761	728	697
	T3	980	951	919	886	855
FPE07E1030D	T1	687	658	626	593	562
	T2 <sup>H</sup>	822	793	761	728	697
	T3	980	951	919	886	855
FPE10E1030D	T1	687	658	626	593	562
	T2 <sup>H</sup>	846	818	785	753	722
	T3	1000	971	939	906	875
FPE15E1030D	T1	687	658	626	593	562
	T2 <sup>H</sup>	1056	1027	995	962	931
	T3	938	909	877	844	813

\*Airflow data shown is with dry coil at 70°F DB EAT with standard 1" air filter.

\*For models with five speed taps, tap T1 is for ventilation. T2 and T3 are for heating operation. T4 and T5 are for cooling operation.

\*Superscript <sup>C</sup> indicates factory-set default cooling tap. Superscript <sup>H</sup> indicates factory-set default heating tap.

Data is subject to change. Please verify most current information on [www.firstco.com](http://www.firstco.com).





FIRST CO.

P.O. BOX 270969 - DALLAS, TEXAS 75227  
PH. (214) 388-5751 | FAX (214) 388-2255

APRIL 2024