



COOL-PAK HP

Space Constrained Heat Pump
with Electric Heating

3/4 - 2.5 Tons

3 - 10 kW Electric Heat

11.9 SEER2

R-454B

ecoseries
COOL-PAK
HP



TABLE OF CONTENTS

NOMENCLATURE3

SERIES FEATURES4

ACCESSORIES.....5

PHYSICAL DATA 12

ELECTRICAL DATA..... 13

COOLING AND HEATING PERFORMANCE 14

EXTENDED PERFORMANCE DATA 15

BLOWER PERFORMANCE 19

SLEEVE AND LOUVER SIZES..... GENERAL ASSEMBLY.....21

CLOSET DIMENSIONS.....23

NOMENCLATURE

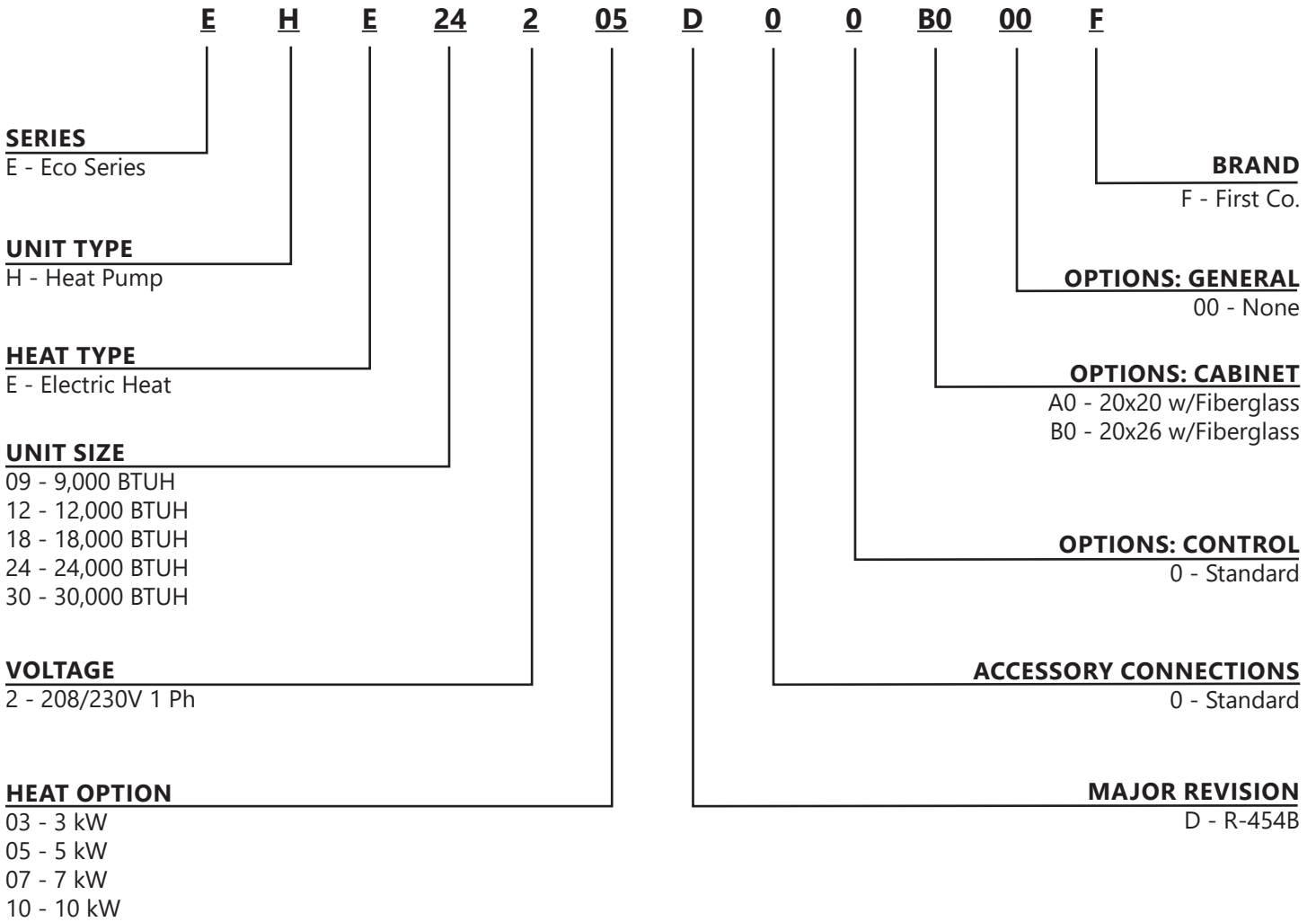

ECO SERIES COOL-PAK HP

SPACE CONSTRAINED HEAT PUMP W/ELECTRIC HEATING

PRODUCT FEATURES / DESCRIPTION

- Space constrained low ambient heat pump with electric heating.
- Pre-wired and pre-charged with R-454B refrigerant, capable of delivering conditioned air to multiple rooms.
- Easily installs into a closet or mechanical room on an exterior wall, utilizing a minimal amount of floor space.
- Controlled by a standard low voltage thermostat with high and low temperature limits.

APPLICATIONS

Hospitality, Apartments/Condominiums, Assisted Living/Memory Care, Student Housing, Senior Living and Modular/Prefabricated Buildings.

STANDARD FEATURES

- Shipped ready for top supply and front return (with optional ducted return)
- Insulated compartment to improve cooling performance, reduce noise, and prevent sweating
- ECM indoor blower & outdoor fan motor to provide precise airflow selection and improve system efficiency
- High efficiency single stage scroll and rotary compressors with double isolated compressor mount to reduce compressor noise and vibration. (Two Stage Scroll available for reduced cabinet size 2-ton unit.)
- Larger evaporator coil with low face velocity for improved cooling performance
- Drain pan with corrosion resistant coating to drain condensate in cooling and heating operations
- Thermal expansion valve (TXV) for both cooling and heating to optimize performance
- Operates down to as low as 5°F ambient temperature with time-temperature defrost board with selectable defrost interval times
- High pressure switch protection
- Electric heat with automatic reset limit switch and non-resettable fuse link
- Filter brackets and disposable filter shipped with unit for field installation; no tool needed to replace filter.
- Multi-function microprocessor control board
- Make-up air vent when fully opened allows up to 50 CFM of ventilation air to be introduced into the closet
- Unit comes standard with one pull out service switch, 10kW units have additional terminal block.
- Units charged with over 4lbs of refrigerant have factory installed leak mitigation sensors

WARNING:

This service switch does not de-energize the incoming power supply to the unit.

SERVICEABILITY FEATURES

- Easy access for in-place service of most components
- Pull out service switch for service and maintenance convenience
- All electrical components and control boards are serviceable from front of the unit

LIMITED WARRANTY

5 Years Compressor, 5 Years parts

ECO SERIES COOL-PAK HP

SPACE CONSTRAINED HEAT PUMP W/ELECTRIC HEATING

REQUIRED ACCESSORIES

- Weight bearing wall sleeves for various wall thicknesses from 5" to 20" shipped with weather and debris guard
- Wall sleeves have primary condensate drain connection with secondary overflow to building exterior
- Flush type aluminum louver with finish and paint options
- Standard low voltage thermostat with high and low temperature limits

OPTIONAL ACCESSORIES

CUSTOM COLOR LOUVERS

STANDARD PAINT COLORS

 <p>SLATE BLUE (LF01)</p>	 <p>MEDIUM BRONZE (LF02)</p>	 <p>SANDSTONE (LF03)</p>
 <p>LIGHT GRAY (LF04)</p>	 <p>CHARCOAL (LF05)</p>	 <p>BONE WHITE (LF06)</p>
 <p>WESTERN TAN (LF07)</p>	 <p>ARCHITECTURAL BRONZE (LF08)</p>	 <p>REGAL BLUE (LF09)</p>
 <p>FOREST GREEN (LF10)</p>	 <p>SURREY BEIGE (LF11)</p>	 <p>ROYAL BROWN (LF12)</p>
 <p>BARN RED (LF13)</p>	 <p>BURGUNDY (LF14)</p>	 <p>CLAY (LF15)</p>
 <p>ALMOND (LF16)</p>	 <p>COASTAL WHITE (LF17)</p>	 <p>VISTA GREEN (LF18)</p>
 <p>BLACK (LF19)</p>	 <p>GLOSS BLACK (LF20)</p>	 <p>CAMPUS GREEN (LF21)</p>

Custom color options available

ECO SERIES COOL-PAK HP

SPACE CONSTRAINED HEAT PUMP W/ELECTRIC HEATING

OPTIONAL ACCESSORIES (CONT'D)

FILTER RACK

Filter Brackets and a disposable filter ship with each unit to be field installed over the evaporator coil.

NOTE: Do not use filters which will cause the total external static pressure including ducts, louvers, registers, and filters to exceed 0.5 in. H₂O.

MULTI-FUNCTION MICROPROCESSOR CONTROL BOARD

Evaporator coil low temperature protection – During the cooling mode, should the evaporator coil experience either a low temperature condition that could result in ice buildup on the coil or a reduced air flow situation, a temperature sensor attached to the coil will de-energize the unit. The sensor will re-energize the unit when the coil warms back up.

Random restart – When power is turned on after a power outage, a built-in random restart delay of 3-4 minutes prevents all compressors from restarting simultaneously.

Compressor restart delay – This delay ensures that system pressures are allowed to equalize before a compressor restart, which extends compressor life.

Fan delay – A fan delay allows the evaporator blower to continue running for up to 45 seconds after the thermostat is satisfied, which maximizes cooling performance.

SERVICE PULL OUT SWITCH

Provides a visible disconnecting means when performing maintenance; models with 10 kW electric heat also have terminal block.

WARNING: The incoming conductors of the service switch remain energized when the service switch is pulled out. Always disconnect power at the main source as well as the service switch before servicing.

ECO SERIES COOL-PAK HP

SPACE CONSTRAINED HEAT PUMP W/ELECTRIC HEATING

VENTILATION AIR

One end of a 3" aluminum vent pipe is connected to the condenser venturi and the other end is connected to the side of the cabinet. A mesh screen and a metal plate on the side of the cabinet covers the opening of the vent pipe.

Up to 50 CFM of ventilation air is introduced into the equipment closet by removing the metal cover plate. The ventilation air mixes with the return air and is then pulled through the evaporator coil and into the supply duct. The cover plate can be reinstalled to partially close the ventilation air opening if less than 50 CFM is desired. An external source of negative pressure (i.e. a bathroom fan) could be used to introduce more than 50 CFM of ventilation air. Consult with factory for further details.

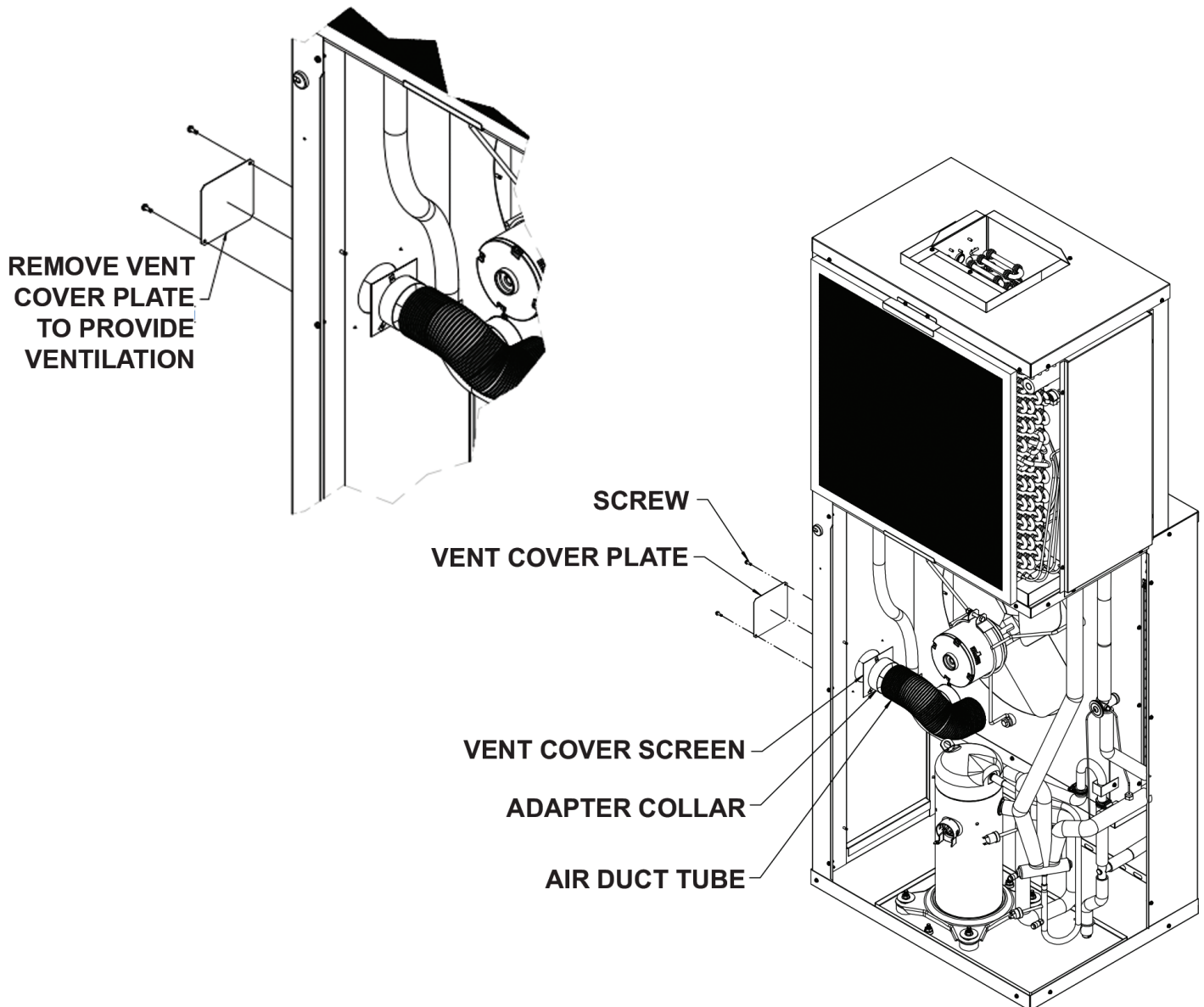

ECO SERIES COOL-PAK HP

SPACE CONSTRAINED HEAT PUMP W/ELECTRIC HEATING

CONDENSATE SYSTEM

Primary Condensate

Factory installed drain line connects the evaporator drain pan to a vertical pipe connection in the unit base pan. Evaporator condensate is delivered from the unit to a catch tray in the wall sleeve and exits the sleeve through the 3/4" male NPT fitting. This design allows the plumber to completely pipe the drain to a condensate riser during the rough-in stage, thus eliminating condensate connection problems usually encountered when trying to connect the HVAC drain to the riser after the HVAC unit is installed in the closet. This feature also allows the unit to be removed for service without disconnecting the condensate piping. This configuration does not require any additional closet space to make the drain connection, as do some competitive products.

Secondary Condensate Overflow

If for any reason the primary condensate riser becomes clogged, water will fill the catch tray and then be diverted through the sleeve to the exterior of the building, rather than be allowed to overflow into the closet or living area. Rain water entering the sleeve is automatically diverted to the 3/4" condensate drain.

REQUIRED ACCESSORIES: WALL SLEEVES

- Provided for installation during rough-in and when ready the unit is simply slid into the wall sleeve and connected to the ductwork and electrical.
- Weight bearing sleeve that supports the entire weight of the unit and provides a weather tight seal against wind and water infiltration.
- Four wall sleeve depths are available to accommodate wall thickness from 5" to 20".
- Includes a weather guard to cover the sleeve opening and a debris guard to cover wall sleeve base and drain during construction.
- Outdoor Louver - Standard colors, custom color, field painted, clear andonized

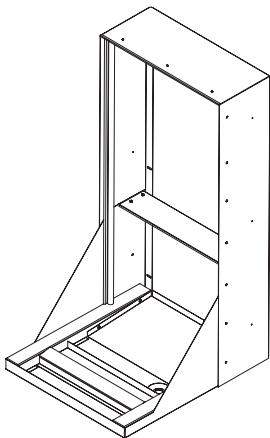

Standard Sleeve
for 3/4 - 2 tons

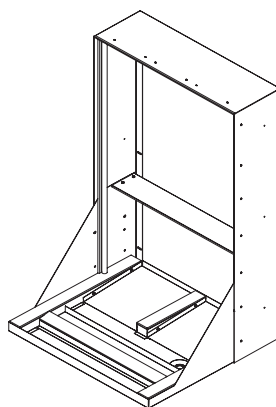

Standard Sleeve
for 2.0 - 2.5 tons

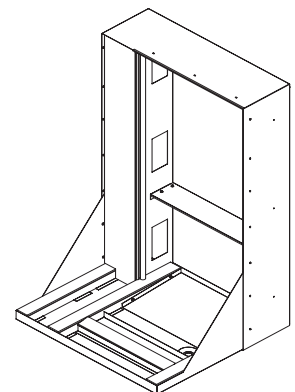

Oversized Sleeve
for 3/4 - 2 tons to provide uni-
form exterior appearance

ECO SERIES COOL-PAK HP



SPACE CONSTRAINED HEAT PUMP W/ELECTRIC HEATING

ACCESSORIES

SLEEVE AND LOUVER ACCESSORIES						
ACCESSORY	DESCRIPTION	DIMENSIONS (H x W x D)	STANDARD SLEEVES		SHIP WT. (EA) Lbs.	
			REAR INSTALL ¹	SIDE INSTALL ²	REAR ⁵	SIDE ⁵
SMALL CABINET "A" WALL SLEEVES	For 5" - 8" thick walls	43-3/4 x 21-3/8 x 26	936-1B	936-11B	59	64
	For 8" - 12" thick walls	43-3/4 x 21-3/8 x 30	936-2B	936-12B	63	73
	For 12" - 15" thick walls	43-3/4 x 21-3/8 x 33	936-3B	936-13B	68	73
	For 15" - 20" thick walls	43-3/4 x 21-3/8 x 38	936-4B	936-14B	75	80
LARGE CABINET "B" WALL SLEEVES	For 5" - 8" thick walls	43-3/4 x 27-3/8 x 26	985-1B	985-11B	63	68
	For 8" - 12" thick walls	43-3/4 x 27-3/8 x 30	985-2B	985-12B	68	73
	For 12" - 15" thick walls	43-3/4 x 27-3/8 x 33	985-3B	985-13B	75	80
	For 15" - 20" thick walls	43-3/4 x 27-3/8 x 38	985-4B	985-14B	79	84
SMALL CABINET "A" LARGE WALL SLEEVES WITH BLOCKOFF	For 5" - 8" thick walls	43-3/4 x 27-3/8 x 26	986-1B	986-11B	63	68
	For 8" - 12" thick walls	43-3/4 x 27-3/8 x 30	986-2B	986-12B	68	73
	For 12" - 15" thick walls	43-3/4 x 27-3/8 x 33	986-3B	986-13B	75	80
	For 15" - 20" thick walls	43-3/4 x 27-3/8 x 38	986-4B	986-14B	79	84
STANDARD LOUVERS CABINET "A" WALL SLEEVES	Custom Painting	44x22	G205S		12	
	For Field Painting	44x22	G205PPA		12	
	Anodized Aluminum	44x22	G205A		12	
STANDARD LOUVERS CABINET "B" LARGE WALL SLEEVES	Custom Painting	44x28	G216S		18	
	For Field Painting	44x28	G216PPA		18	
	Anodized Aluminum	44x28	G216A		18	

NOTES:

1. Rear install application provides better access to the unit and is recommended over side install wherever possible.
2. Side install application requires different closet size and configuration. Contact factory for further information.
3. Wind resistant sleeves require the usage of a wind resistant louver.
4. S indicates custom color, to be provided by customer. Minimum order quantity is 15 per color, if less than 15 set up fees will be applied.
5. All wall sleeves are shipped two (2) per carton, fully assembled.

THERMOSTATS			
Heat Pump (24V) Digital w/emergency heat cool - off - heat, auto - on w/limits-(6-wire)	4 x 5 (Horizontal)	T1220NC	
Programmable (5-2) St. Cool/Ht. Pump (24V) cool-off-heat, auto-on w/em. Ht. & limits (6-wire)	4 x 5 (Horizontal)	T2220NC	
Straight Cool or Heat Pump (24V) Digital Occupancy Sensor	4.3 x 5.7 (Horizontal)	T8532	

ECO SERIES COOL-PAK HP

SPACE CONSTRAINED HEAT PUMP W/ELECTRIC HEATING

ACCESSORIES (CONT'D)

OPTIONAL ACCESSORIES (FIELD INSTALLED)							
COMPONENT	DESCRIPTION	DIMENSIONS (H X W)		PART NUMBER	SHIPPING WEIGHT	EQUIPPED WITH FILTER	
ACCESS/RETURN AIR PANEL (3)(4)	LOUVERED (1)	FRAME	OPENING	931-11	55	20 x 24 x 1	
		87 X 31	84 X 28				
	NON-LOUVERED (2)	87 X 31	84 X 28	931-12		NO	
	LOUVERED (1)	82 X 31	79 X 28	931-13		20 x 24 x 1	
	NON-LOUVERED (2)	82 X 31	79 X 28	931-14		NO	
ACCESS/RETURN AIR PANEL (3)(4)	LOUVERED (1)	FRAME	OPENING	931-15		55	20 x 24 x 1
		87 X 37	84 X 34				
	NON-LOUVERED (2)	87 X 37	84 X 34	931-16			NO
	LOUVERED (1)	82 X 37	79 X 34	931-17	20 x 24 x 1		
	NON-LOUVERED (2)	82 X 37	79 X 34	931-18	NO		
9-24A INSULATION KIT	5/8" DUCTBOARD	N/A		91K01	---		---
24B-30 INSULATION KIT				91K02	---		---

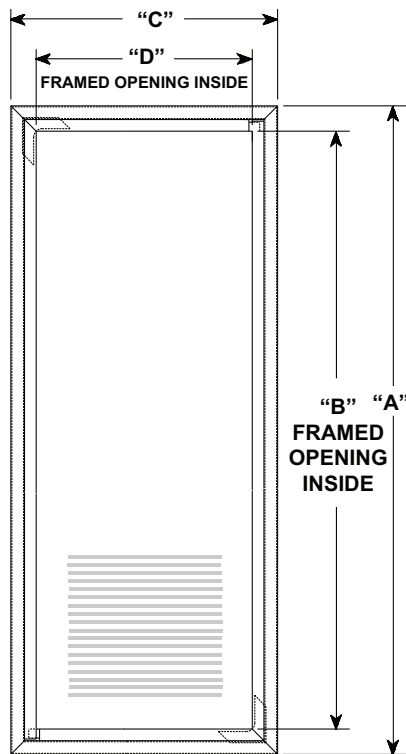

- * For rear installation use with size 24 or 30
 NOTE: A solid door or panel with a side wall return air louver will result in lower sound levels.
 NOTES:
 (1) Includes 18 x 24 x 1 or 20 x 24 x 1 filter.
 (2) Requires external return air louver and unit mount filter.
 (3) Both panels are insulated for sound reduction and have tamperproof screws.
 (4) Panels are shipped ten per carton.

PART NO.	"A"	"B"	"C"	"D"
931-11(12)	87.00	84.00	31.00	28.00
931-13(14)	82.00	79.00	31.00	28.00
*931-15(16)	87.00	84.00	37.00	34.00
*931-17(18)	82.00	79.00	37.00	34.00

ECO SERIES COOL-PAK HP

SPACE CONSTRAINED HEAT PUMP W/ELECTRIC HEATING

ACCESSORIES UNIT DIMENSIONS

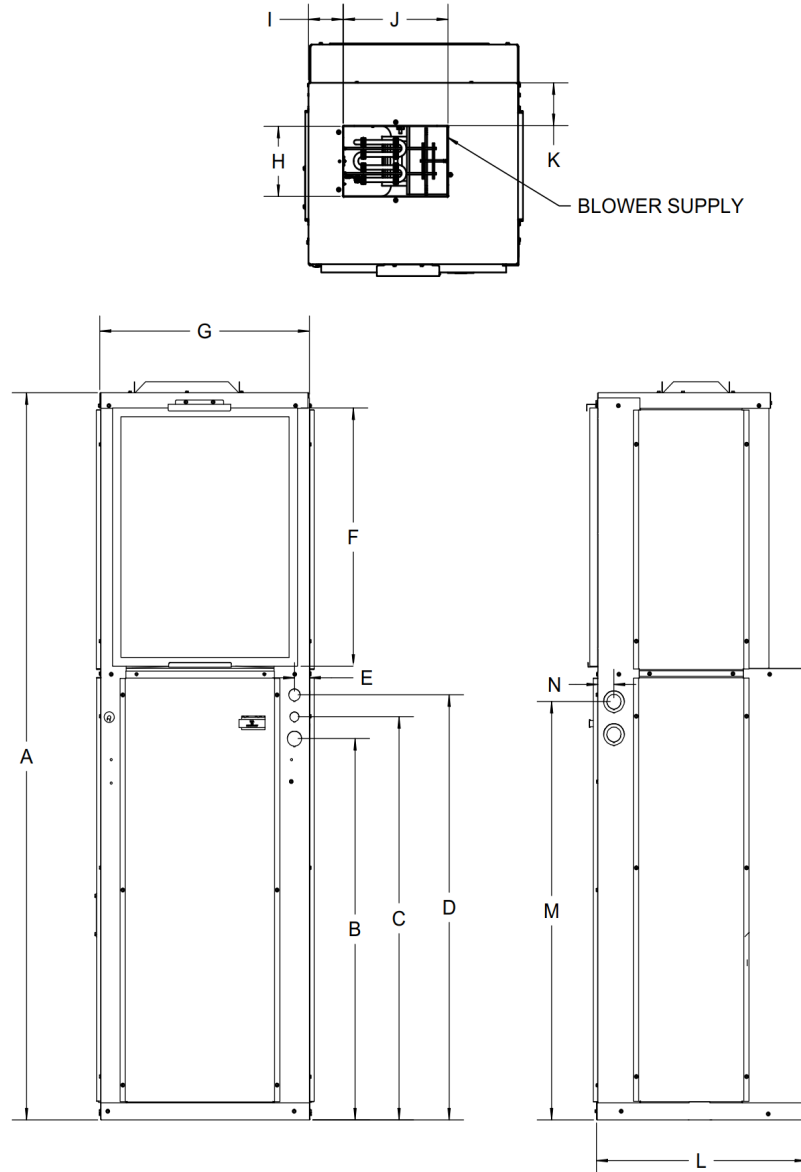

COOL -PAK HP														
MODEL NUMBER	A	B	C	D	E	F	G	H	I	J	K	L	M	N
	CABINET DIMENSIONS							SUPPLY CONNECTIONS						
EHE09***A	66.5	34.9	36.9	38.9	1.4	23.6	20.9	6.4	3.3	10.0	3.9	20.1	38.2	1.6
EHE12***A	66.5	34.9	36.9	38.9	1.4	23.6	20.9	6.4	3.3	10.0	3.9	20.1	38.2	1.6
EHE18***A	66.5	34.9	36.9	38.9	1.4	23.6	20.9	6.4	3.3	10.0	3.9	20.1	38.2	1.6
EHE24***A	66.5	34.9	36.9	38.9	1.4	23.6	20.9	6.4	3.3	10.0	3.9	20.1	38.2	1.6
EHE24***B	66.5	34.9	36.9	38.9	1.4	23.7	26.9	10.0	7.9	10.0	3.9	20.1	38.2	1.6
EHE30***B	66.5	34.9	36.9	38.9	1.4	23.7	26.9	10.0	7.9	10.0	3.9	20.1	38.2	1.6

NOTE:
24A is for the smaller cabinet.

ECO SERIES COOL-PAK HP

SPACE CONSTRAINED HEAT PUMP W/ELECTRIC HEATING

COOL-PAK HP – PHYSICAL DATA							
454B COOL PAK HP	EHE09	EHE12	EHE18	EHE24B	EHE24A	EHE30	
Compressor (Quantity)	Rotary (1)				Scroll (two stage)	Scroll (1)	
Compressor FLA	3.9	4.8	7.5	11.4	9.7	11.7	
Factory Charge (R-454B)	Lb	2.7	3.2	4	5.25	4.25	5
	Kg	1.22	1.45	1.81	2.38	1.92	2.26
Minimum Rm. Area	m²	3.68	4.38	5.47	7.19	5.80	6.83
Minimum Rm. Area	Ft²	40	47	59	77	62	73
Minimum Air Flow	CFM	73	86	108	142	115	135
	M³/hr	124	147	183	241	195	229
ID MOTOR							
Motor (Quantity)	1	1	1	1	1	1	
Fan Motor Type	ECM	ECM	ECM	ECM	ECM	ECM	
Motor HP	1/4	1/4	1/3	1/3	1/3	1/2	
Motor FLA	2.3	2.3	2.8	2.8	2.8	4.1	
OD MOTOR							
Motor (Quantity)	1	1	1	1	1	1	
Fan Motor Type	ECM	ECM	ECM	ECM	ECM	ECM	
Motor HP	1/4	1/4	1/4	1/4	1/4	1/3	
Motor FLA	2.3	2.3	2.3	2.3	2.3	2.8	
ID BLOWER							
Blowers (Quantity)	1	1	1	1	1	1	
Blower Wheel Size (D x W) in. [cm]	6 x 7	6 x 7	9 x 4	9 x 4	9 x 4	9 x 4	
	[15.3 x 17.78]	[15.3 x 17.78]	[22.9 x 10.16]	[22.9 x 10.16]	[22.9 x 10.16]	[22.9 x 10.16]	
EVAPORATOR COIL							
Dimensions (H x W) in. [cm]	24 x 16.25	24 x 16.25	24 x 16.25	24x22	24 x 16.25	24x22	
	[61 x 41.275]	[61 x 41.275]	[61 x 41.275]	[61 x 55.88]	[61 x 41.275]	[61 x 55.88]	
Face Area ft² [m²]	3.53 [2.70]	3.53 [2.70]	3.53 [2.70]	3.53 [0.33]	3.53 [2.70]	3.53 [0.33]	
Rows	2	3	4	4	4	4	
OD COIL							
Dimensions (H x W) in. [cm]	26 x 16.5	26 x 16.5	26 x 16.5	26 x 22.5	26 x 16.5	26 x 22.5	
	[66 x 42]	[66 x 42]	[66 x 42]	[66 x 57]	[66 x 42]	[66 x 57]	
Face Area ft² [m²]	3.0 [0.2772]	3.0 [0.2772]	3.0 [0.2772]	4.1 [0.3762]	3.0 [0.2772]	4.1 [0.3762]	
Rows	2	3	4	4	4	4	
MISCELLANEOUS							
Throwaway Filter Dim. in. [cm]	18 x 24	18 x 24	18 x 24	24 x 24	18 x 24	24 x 24	
	[45.72 x 60.96]	[45.72 x 60.96]	[45.72 x 60.96]	[60.96 x 60.96]	[45.72 x 60.96]	[60.96 x 60.96]	
Throwaway Filter Quantity	1	1	1	1	1	1	
A2L Mitigation	NO	NO	NO	YES	YES	YES	
Operating Weight lb. [oz]	290 [132]	290 [132]	295 [134]	310 [141]	295 [134]	320 [145]	
Packaged Weight lb. [oz]	310 [141]	310 [141]	315 [143]	330 [150]	315 [143]	340 [154]	

ECO SERIES COOL-PAK HP

SPACE CONSTRAINED HEAT PUMP W/ELECTRIC HEATING

ELECTRICAL DATA

COOL-PAK HP – (208/240V 1-PH-60HZ)																					
UNIT MODEL		ELECTRICAL HEAT DATA						BLOWER DATA		CONDENSER DATA				MINIMUM CIRCUIT AMAPACITY				MAXIMUM CIRCUIT PROTECTION			
		KW		BTUH		TOTAL HEATING AMPS		EVAPORATOR MOTOR		COMPRESSOR		CONDENSER MOTOR		CKT 1		CKT 2		CKT 1		CKT 2	
		240V	208V	240V	208V	240V	208V	AMPS	HP	RLA	LRA	AMPS	HP	240V	208V	240V	208V	240V	208V	240V	208V
EHE09	-03	3	2.25	10230	7670	13	11	2.3	1/4	4	22	2.3	1/4	25	23	0	0	30	25	0	0
EHE12	-03	3	2.25	10230	7670	13	11	2.3	1/4	4.6	25	2.3	1/4	26	24	0	0	30	25	0	0
	-05	4.5	3.38	15350	11530	19	16	2.3	1/4	4.6	25	2.3	1/4	34	31	0	0	35	35	0	0
EHE18	-03	3	2.25	10230	7670	13	11	2.8	1/3	7.6	36	2.3	1/4	30	28	0	0	35	30	0	0
	-05	5	3.75	17060	12790	21	18	2.8	1/3	7.6	36	2.3	1/4	41	37	0	0	45	40	0	0
	-07	7	5.25	23880	17910	29	25	2.8	1/3	7.6	36	2.3	1/4	51	46	0	0	55	50	0	0
	-10	9.5	7.125	32410	24310	40	34	2.8	1/3	7.6	36	2.3	1/4	15	15	49	43	15	15	50	45
EHE24A	-05	5	3.75	17060	12790	21	18	2.8	1/3	10.2	58	2.3	1/4	44	40	0	0	45	45	0	0
	-07	7	5.25	23880	17910	29	25	2.8	1/3	10.2	58	2.3	1/4	54	49	0	0	55	50	0	0
	-10	9.5	7.125	32410	24310	40	34	2.8	1/3	10.2	58	2.3	1/4	18	18	49	43	25	25	50	45
EHE24B	-05	5	3.75	17060	12790	21	18	2.8	1/3	9.6	52	2.3	1/4	43	40	0	0	45	40	0	0
	-07	7	5.25	23880	17910	29	25	2.8	1/3	9.6	52	2.3	1/4	54	49	0	0	55	50	0	0
	-10	9.5	7.125	32410	24310	40	34	2.8	1/3	9.6	52	2.3	1/4	17	17	49	43	20	20	50	45
EHE30	-05	5	3.75	17060	12790	21	18	4.1	1/2	10.5	71	2.8	1/3	46	43	0	0	50	45	0	0
	-07	7	5.25	23880	17910	29	25	4.1	1/2	10.5	71	2.8	1/3	56	52	0	0	60	55	0	0
	-10	9.5	7.125	32410	24310	40	34	4.1	1/2	10.5	71	2.8	1/3	20	20	49	43	25	25	50	45

*Circuits 1 and 2 require separate sets of power wires connected to the unit, each backed by an independent circuit breaker.

For 3kW, 5kW, and 7kW models, Circuit 1 is used for compressor power, condenser fan power, evaporator motor power and first stage of electric heat

10kW models, Circuit 1 is used for compressor power, condenser fan power and the first stage of electric heat, and the evaporator motor. Circuit 2 is used for the 2nd stage of electric heat.

Refer to wiring diagrams in the EHE Installation and Operation Manual for additional details.

Wire size should be determined in accordance with National Electric Codes.

Units are rated for 208/230V, but MOP, MCA values are calculated at 208/240V.

Data is subject to change. Please verify most current information on www.firstco.com.

ECO SERIES COOL-PAK HP

SPACE CONSTRAINED HEAT PUMP W/ELECTRIC HEATING

RATED COOLING & HEATING PERFORMANCE

COOL -PAK HP							
Model	Rated Airflow SCFM	Cooling Capacity 95°F, BTUH	EER2 95°F	SEER2	Heating Capacity 47°F, BTUH	Heating Capacity 17°F, BTUH	HSPF2
EHE09***D	300	9000	10.0	11.9	8800	5000	6.3
EHE12***D	400	11500	10.0	11.9	11100	5300	6.3
EHE18***D	600	17500	10.0	11.9	16500	10000	6.3
EHE24A***D	800/600	22400	10.0	11.9	22400	14500	6.3
EHE24B***D	800	24500	10.0	11.9	23600	14500	6.3
EHE30***D	950	26500	10.0	11.9	25400	16000	6.3

NOTE:

24A is for the smaller cabinet.
Ratings subject to change

ELECTRIC HEAT RATINGS						
Model	240V		230V		208V	
	kW	BTU/H	kW	BTU/H	kW	BTU/H
EHE09203*	3	10250	2.8	9450	2.3	7700
EHE12203*	3	10250	2.8	9450	2.3	7700
EHE12205*	4.5	15400	4.1	14150	3.4	11550
EHE18203*	3	10250	2.8	9450	2.3	7700
EHE18205*	5	17100	4.6	15700	3.8	12800
EHE18207*	7	23900	6.4	22000	5.3	17950
EHE18210*	9.5	32450	8.7	29850	7.1	24350
EHE24205*	5	17100	4.6	15700	3.8	12800
EHE24207*	7	23900	6.4	22000	5.3	17950
EHE24210*	9.5	32450	8.7	29850	7.1	24350
EHE30205*	5	17100	4.6	15700	3.8	12800
EHE30207*	7	23900	6.4	22000	5.3	17950
EHE30210*	9.5	32450	8.7	29850	7.1	24350

7kW and 10kW heating value shown are for both stages of electric heat
Data is subject to change. Please verify most current information on www.firstco.com.

ECO SERIES COOL-PAK HP

SPACE CONSTRAINED HEAT PUMP W/ELECTRIC HEATING

EXTENDED PERFORMANCE DATA

EXTENDED HEATING CAPACITY, COMPRESSOR ONLY													
MODEL	Air Flow SCFM	47/43			35/33			17/15			5/0		
		Net Capacity	Power Input	Outlet Dry Bulb	Net Capacity	Power Input	Outlet Dry Bulb	Net Capacity	Power Input	Outlet Dry Bulb	Net Capacity	Power Input	Outlet Dry Bulb
		BTUH	kW	°F	BTUH	kW	°F	BTUH	kW	°F	BTUH	kW	°F
EHE09*A	300	8800	0.80	93	7000	0.76	90	5000	0.69	84	4000	0.67	81
EHE12*A	400	11100	0.90	99	8700	0.87	93	6800	0.83	88	5300	0.76	83
EHE18*A	600	16500	1.40	95	12800	1.38	90	10000	1.25	85	8000	1.20	82
EHE24*A	800/600	22500	1.94	95	17000	1.85	91	14500	1.81	86	12000	1.77	83
EHE24*B	800	23600	1.92	98	18400	1.85	92	14500	1.75	87	12200	1.70	81
EHE30*B	900	25400	2.19	96	21000	2.15	92	16000	2.07	86	13000	2.03	83

Capacities based off 70°F EAT at .3 in. H₂O of external static.

Airflow run at the default cooling blower speed tap

Capacities include both stage of electric heat for 7kW and 10kW models.

HEAT PUMP EXTENDED DATA W/ELECTRIC HEAT									
Model	Heater Size, 240V kW	47/43				35/33			
		240V		208V		240V		208V	
		Net Capacity	Power Input	Net Capacity	Power Input	Net Capacity	Power Input	Net Capacity	Power Input
		BTU/H	kW	BTU/H	kW	BTU/H	kW	BTU/H	kW
EHE09203*D*A	3	19030	3.8	16470	3.05	17230	3.76	14670	3.01
EHE12203*D*A	3	21330	3.9	18770	3.15	18930	3.87	16370	3.12
EHE12205*D*A	5	28160	5.9	23890	4.65	25760	5.87	21490	4.62
EHE18203*D*A	3	26730	4.4	24170	3.65	23030	4.38	20470	3.63
EHE18205*D*A	5	33560	6.4	29290	5.15	29860	6.38	25590	5.13
EHE18207*D*A	7	40380	8.4	34410	6.65	36680	8.38	30710	6.63
EHE18210*D*A	9.5	48910	10.9	40810	8.52	45210	10.88	37110	8.50
EHE24205*D*A	5	39560	6.94	35290	5.69	34060	6.85	29790	5.60
EHE24207*D*A	7	46380	8.94	40410	7.19	40880	8.85	34910	7.10
EHE24210*D*A	9.5	54910	11.44	46810	9.06	49410	11.35	41310	8.97
EHE24205*D*B	5	40660	6.92	35290	5.69	35460	6.85	29790	5.60
EHE24205*D*B	7	47480	8.92	40410	7.19	42280	8.85	34910	7.10
EHE24205*D*B	9.5	56010	11.42	46810	9.06	50810	11.35	41310	8.97
EHE30205*D*B	5	42460	7.19	38190	5.94	38060	7.15	33790	5.90
EHE30207*D*B	7	49280	9.19	43310	7.44	44880	9.15	38910	7.40
EHE30210*D*B	9.5	57810	11.69	49710	9.31	53410	11.65	45310	9.27

Capacities based off 70°F EAT at .3 in. H₂O of external static.

Airflow run at the default heating blower speed tap

Capacities include both stage of electric heat for 7kW and 10kW models.

Data is subject to change. Please verify most current information on www.firstco.com.

ECO SERIES COOL-PAK HP

SPACE CONSTRAINED HEAT PUMP W/ELECTRIC HEATING

EXTENDED PERFORMANCE DATA (CONT'D)

HEAT PUMP EXTENDED DATA WITH ELECTRIC HEAT									
Model	Heater Size, 240V kW	17/15				5/0			
		240V		208V		240V		208V	
		Net Capacity	Power Input	Net Capacity	Power Input	Net Capacity	Power Input	Net Capacity	Power Input
		BTUH	kW	BTUH	kW	BTUH	kW	BTUH	kW
EHE09203*D*A	3	15230	3.69	12670	2.94	14230	3.67	11670	2.92
EHE12203*D*A	3	17030	3.83	14470	3.08	15530	3.76	12970	3.01
EHE12205*D*A	5	23860	5.83	19590	4.58	22360	5.76	18090	4.51
EHE18203*D*A	3	20230	4.25	17670	3.50	18230	4.20	15670	3.45
EHE18205*D*A	5	27060	6.25	22790	5.00	25060	6.20	20790	4.95
EHE18207*D*A	7	33880	8.25	27910	6.50	31880	8.20	25910	6.45
EHE18210*D*A	9.5	42410	10.75	34310	8.37	40410	10.70	32310	8.32
EHE24205*D*A	5	31560	6.81	27290	5.56	29060	6.77	24790	5.52
EHE24207*D*A	7	38380	8.81	32410	7.06	35880	8.77	29910	7.02
EHE24210*D*A	9.5	46910	11.31	38810	8.93	44410	11.27	36310	8.89
EHE24205*D*B	5	31560	6.75	27290	5.56	29260	6.77	24790	5.52
EHE24205*D*B	7	38380	8.75	32410	7.06	36080	8.77	29910	7.02
EHE24205*D*B	9.5	46910	11.25	38810	8.93	44610	11.27	36310	8.89
EHE30205*D*B	5	33060	7.07	28790	5.82	30060	7.03	25790	5.78
EHE30207*D*B	7	39880	9.07	33910	7.32	36880	9.03	30910	7.28
EHE30210*D*B	9.5	48410	11.57	40310	9.19	45410	11.53	37310	9.15

Capacities based off 70°F EAT at .3 in. H₂O of external static.

Airflow run at the default heating blower speed tap

Capacities include both stage of electric heat for 7kW and 10kW models.

Data is subject to change. Please verify most current information on www.firstco.com.

ECO SERIES COOL-PAK HP

SPACE CONSTRAINED HEAT PUMP W/ELECTRIC HEATING

EXTENDED PERFORMANCE DATA (CONT'D)

EXTENDED COOLING PERFORMANCE										
Model	Indoor Temp DB/WB	Outdoor Temperature °F								
		65.0			75.0			85.0		
		BTUH	S/T	kW	BTUH	S/T	kW	BTUH	S/T	kW
EHE09*A	75/57	8700	1.00	0.50	8350	1.00	0.60	7950	1.00	0.60
	75/63	9750	0.76	0.50	9250	0.80	0.60	8750	0.79	0.60
	80/67	10650	0.73	0.50	10100	0.70	0.60	9550	0.76	0.60
	85/72	11900	0.65	0.50	11300	0.70	0.60	10750	0.68	0.60
EHE12*A	75/57	12050	1	0.69	11250	1	0.79	10700	1	0.79
	75/63	12900	0.75	0.69	12200	0.77	0.79	11450	0.79	0.79
	80/67	13800	0.72	0.69	13000	0.74	0.79	12250	0.76	0.79
	85/72	15200	0.62	0.69	14350	0.63	0.79	13550	0.65	0.79
EHE18*A	75/57	18300	1	1.10	17450	1	1.30	16650	1	1.40
	75/63	19450	0.79	1.20	18450	0.81	1.30	17400	0.84	1.40
	80/67	20700	0.77	1.20	19700	0.79	1.30	18600	0.81	1.50
	85/72	22350	0.7	1.10	21250	0.72	1.30	20100	0.74	1.40
EHE24*A	75/57	23300	1	1.70	22250	1	1.90	20650	1	2.30
	75/63	24800	0.75	1.80	23500	0.77	1.90	22200	0.79	2.10
	80/67	26550	0.73	1.80	25200	0.75	1.90	23750	0.76	2.10
	85/72	29050	0.66	1.80	27550	0.68	2.00	26000	0.69	2.10
EHE24*B	75/57	25400	1	1.60	24350	1	1.90	22750	1	2.10
	75/63	26900	0.72	1.60	25600	0.74	1.90	24300	0.76	2.10
	80/67	28650	0.71	1.60	27300	0.73	1.90	25850	0.74	2.10
	85/72	31150	0.64	1.60	29650	0.66	1.90	28100	0.67	2.10
EHE30*B	75/57	26400	0.99	1.80	25400	1	1.90	24650	1	2.20
	75/63	29100	0.72	1.80	27700	0.74	2.00	26250	0.75	2.20
	80/67	31050	0.69	1.90	29550	0.71	2.10	28000	0.72	2.30
	85/72	33750	0.63	1.90	32050	0.64	2.10	30500	0.65	2.30

Extended cooling performance data tabulated based off test at rated Airflow at .3 in. H₂O of external static.

24A is for the smaller cabinet

Data is subject to change. Please verify most current information on www.firstco.com.

ECO SERIES COOL-PAK HP

SPACE CONSTRAINED HEAT PUMP W/ELECTRIC HEATING

EXTENDED PERFORMANCE DATA (CONT'D)

EXTENDED COOLING PERFORMANCE										
Model	Indoor Temp DB/WB	Outdoor Temperature°F								
		95.0			105.0			115.0		
		BTUH	S/T	kW	BTUH	S/T	kW	BTUH	S/T	kW
EHE09*A	75/57	7550	1.00	0.74	7150	1.00	0.80	6750	1.00	0.80
	75/63	8200	0.82	0.74	7700	0.84	0.80	7150	0.87	0.80
	80/67	9000	0.82	0.74	8450	0.81	0.80	7900	0.83	0.90
	85/72	10150	0.70	0.74	9550	0.72	0.80	8950	0.74	0.90
EHE12*A	75/57	10100	1	0.99	9500	1	0.89	8900	1	1.09
	75/63	10750	0.81	0.99	10000	0.84	0.89	9250	0.88	1.09
	80/67	11500	0.76	0.99	10700	0.82	0.89	9950	0.85	1.09
	85/72	12650	0.67	0.99	11850	0.69	0.89	10950	0.72	1.09
EHE18*A	75/57	15750	1	1.50	14900	1	1.70	13950	1	1.80
	75/63	16350	0.86	1.50	15350	0.9	1.70	14250	0.93	1.80
	80/67	17500	0.76	1.60	16350	0.87	1.70	15300	0.91	1.90
	85/72	18950	0.76	1.60	17750	0.79	1.70	16600	0.83	1.90
EHE24*A	75/57	19600	1	2.40	18450	1	2.60	17250	1	3.00
	75/63	20800	0.81	2.40	19450	0.84	2.60	18000	0.87	3.00
	80/67	22400	0.79	2.40	20850	0.81	2.60	19400	0.84	3.00
	85/72	24500	0.71	2.40	22850	0.73	2.70	21000	0.75	3.00
EHE24*B	75/57	21700	1	2.40	20550	1	2.50	19100	1	2.80
	75/63	22900	0.78	2.40	21550	0.81	2.50	20000	0.84	2.80
	80/67	24500	0.77	2.40	22950	0.79	2.50	21300	0.82	2.80
	85/72	26600	0.69	2.40	24950	0.71	2.50	23200	0.73	2.80
EHE30*B	75/57	22900	1	2.40	21800	1	2.60	20600	1	2.90
	75/63	24750	0.76	2.40	23300	0.79	2.70	21900	0.81	2.90
	80/67	26500	0.79	2.50	24950	0.76	2.80	23400	0.79	3.10
	85/72	28750	0.67	2.50	27100	0.69	2.80	25400	0.71	3.10

Extended cooling performance data tabulated based off test at rated Airflow at .3 in. H₂O of external static.

24A is for the smaller cabinet

Data is subject to change. Please verify most current information on www.firstco.com.

ECO SERIES COOL-PAK HP

SPACE CONSTRAINED HEAT PUMP W/ELECTRIC HEATING

BLOWER PERFORMANCE

COOL -PAK HP												
MODEL	Motor Tap	Motor Speed	IWC STATIC PRESSURE									
			0.10		0.20		0.30		0.40		0.50	
			SCFM	W	SCFM	W	SCFM	W	SCFM	W	SCFM	W
EHE09203*A	1	T1	317	51	300	49	281	49	263	49	244	48
	2	T2 ^C	358	64	341	63	322	62	303	62	285	61
	3	T3	459	103	441	102	423	101	404	101	385	100
	4	T4 ^H	395	77	378	76	359	75	340	75	322	74
EHE12203*A	1	T1	358	64	341	63	322	62	303	62	285	61
	2	T2 ^C	459	103	441	102	423	101	404	101	385	100
	3	T3	552	152	535	151	516	151	498	150	479	149
	4	T4 ^H	510	128	493	127	474	127	456	126	437	125
EHE12205*A	1	T1	358	64	341	63	322	62	303	62	285	61
	2	T2 ^C	459	103	441	102	423	101	404	101	385	100
	3	T3	552	152	535	151	516	151	498	150	479	149
	4	T4 ^H	510	128	493	127	474	127	456	126	437	125
EHE182203*A	1	T1	392	47	366	47	343	47	311	43	267	35
	2	T2 ^H	629	111	603	111	579	111	548	107	504	99
	3	T3	820	206	793	206	770	206	738	202	695	194
	4	T4 ^C	723	155	696	155	673	155	641	151	598	143
	5	T5	820	206	793	206	770	206	738	202	695	194
EHE182205*A	1	T1	392	47	366	47	343	47	311	43	267	35
	2	T2 ^H	629	111	603	111	579	111	548	107	504	99
	3	T3	820	206	793	206	770	206	738	202	695	194
	4	T4 ^C	723	155	696	155	673	155	641	151	598	143
	5	T5	820	206	793	206	770	206	738	202	695	194
EHE182207*A	1	T1	371	36	351	43	330	50	310	57	292	64
	2	T2 ^H	623	101	603	107	582	114	562	122	543	129
	3	T3	802	179	782	186	762	193	742	200	723	207
	4	T4 ^C	709	134	689	141	669	148	649	155	630	162
	5	T5	802	179	782	186	762	193	742	200	723	207
EHE182210*A	1	T1	371	36	351	43	330	50	310	57	292	64
	2	T2 ^H	623	101	603	107	582	114	562	122	543	129
	3	T3	802	179	782	186	762	193	742	200	723	207
	4	T4 ^C	709	134	689	141	669	148	649	155	630	162
	5	T5	945	269	925	276	904	283	884	290	865	297
EHE24205*A	1	T1	573	89	546	88	523	89	491	85	448	77
	2	T2 ^H	820	206	793	206	770	206	738	202	695	194
	3	T3 ^{low}	703	145	676	145	653	145	621	141	578	133
	4	T4 ^{high}	904	253	878	253	854	253	823	249	779	241
	5	T5	945	277	918	277	895	278	863	274	820	265

^C Factory Default Cooling and Heat Pump Airflow.
^H Factory Default Electric Heat Airflow.
 T1 is reserved for Fan Only Operation (All models).
 24A is for the smaller cabinet.

Blower performance data based on a dry coil at 70°F DB EAT with a standard 1" clean air filter.
 Data is subject to change.
 Please verify most current information on www.firstco.com.

ECO SERIES COOL-PAK HP

SPACE CONSTRAINED HEAT PUMP W/ELECTRIC HEATING

COOL-PAK HP BLOWER PERFORMANCE (CONT'D)												
MODEL	Motor Tap	Motor Speed	IWC STATIC PRESSURE									
			0.10		0.20		0.30		0.40		0.50	
			SCFM	W	SCFM	W	SCFM	W	SCFM	W	SCFM	W
EHE24207*A	1	T1	569	84	549	90	528	97	508	105	489	111
	2	T2 ^H	802	179	782	186	762	193	742	200	723	207
	3	T3 ^{Clow}	691	126	671	133	650	140	630	147	612	154
	4	T4 ^{Chigh}	899	237	879	244	858	251	838	258	819	265
	5	T5	963	283	943	290	922	297	902	304	883	311
EHE24210*A	1	T1	569	84	549	90	528	97	508	105	489	111
	2	T2 ^H	878	224	858	230	837	237	817	245	798	251
	3	T3 ^{Clow}	691	126	671	133	650	140	630	147	612	154
	4	T4 ^{Chigh}	899	237	879	244	858	251	838	258	819	265
	5	T5	963	283	943	290	922	297	902	304	883	311
EHE24205*B	1	T1	523	70	493	70	462	69	429	66	391	62
	2	T2 ^H	864	209	834	210	803	208	770	206	732	201
	3	T3	940	265	909	265	878	264	846	261	807	257
	4	T4 ^C	864	209	834	210	803	208	770	206	732	201
	5	T5	966	291	936	291	905	289	872	287	834	282
EHE24207*B	1	T1	523	70	493	70	462	69	429	66	391	62
	2	T2 ^H	864	209	834	210	803	208	770	206	732	201
	3	T3	940	265	909	265	878	264	846	261	807	257
	4	T4 ^C	864	209	834	210	803	208	770	206	732	201
	5	T5	966	291	936	291	905	289	872	287	834	282
EHE24210*B	1	T1	523	70	493	70	462	69	429	66	391	62
	2	T2 ^H	864	209	834	210	803	208	770	206	732	201
	3	T3	940	265	909	265	878	264	846	261	807	257
	4	T4 ^C	864	209	834	210	803	208	770	206	732	201
	5	T5	966	291	936	291	905	289	872	287	834	282
EHE30205*B	1	T1	525	68	502	75	479	81	456	87	436	94
	2	T2 ^H	864	205	842	211	818	217	796	224	775	231
	3	T3	943	256	921	262	897	268	875	274	854	281
	4	T4 ^C	864	205	842	211	818	217	796	224	775	231
	5	T5	969	274	946	280	923	286	901	293	880	299
EHE30207*B	1	T1	637	136	614	137	586	134	557	128	527	122
	2	T2 ^H	1032	338	1009	339	981	336	952	330	922	324
	3	T3	1098	395	1074	396	1047	393	1017	387	987	381
	4	T4 ^C	1032	338	1009	339	981	336	952	330	922	324
	5	T5	1165	465	1142	466	1114	462	1085	457	1055	450
EHE30210*B	1	T1	637	136	614	137	586	134	557	128	527	122
	2	T2 ^H	1032	338	1009	339	981	336	952	330	922	324
	3	T3	1098	395	1074	396	1047	393	1017	387	987	381
	4	T4 ^C	1032	338	1009	339	981	336	952	330	922	324
	5	T5	1165	465	1142	466	1114	462	1085	457	1055	450

C Factory Default Cooling and Heat Pump Airflow.
 H Factory Default Electric Heat Airflow.
 T1 is reserved for Fan Only Operation (All models.)
 Blower performance data based on a dry coil at 70°F DB EAT with
 a standard 1" clean air filter.

24A is for the smaller cabinet
 Data is subject to change.
 Please verify most current information on www.firstco.com.

ECO SERIES COOL-PAK HP

SPACE CONSTRAINED HEAT PUMP W/ELECTRIC HEATING

GENERAL ASSEMBLY FOR STANDARD SLEEVE AND LOUVER

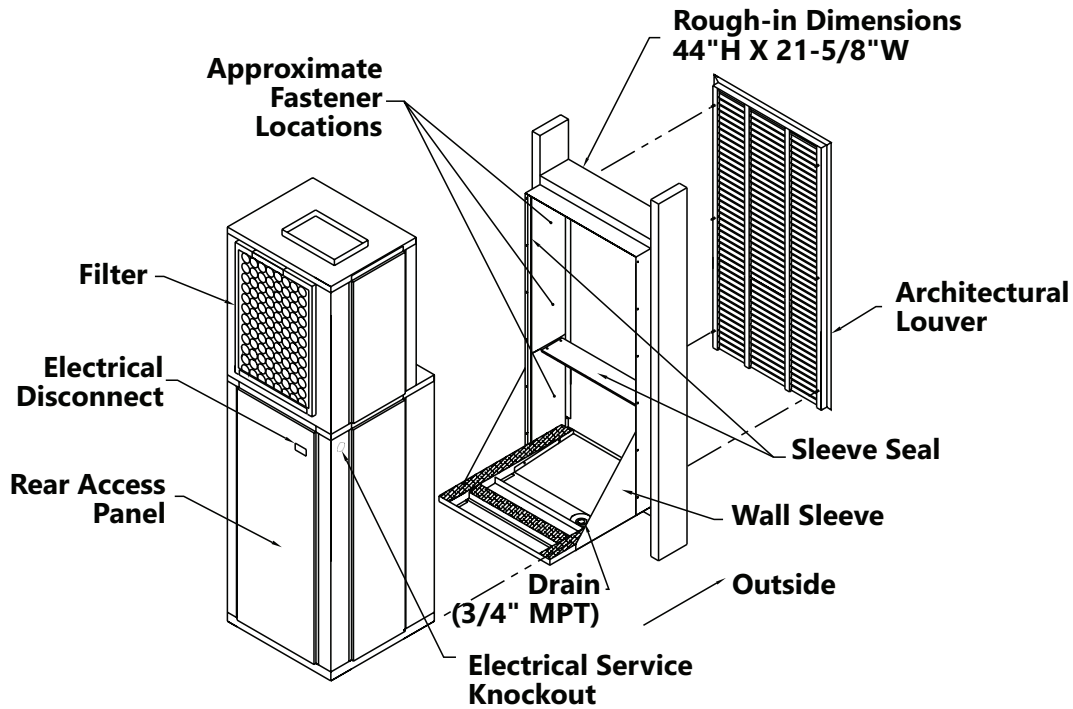

GENERAL ASSEMBLY FOR LARGE SLEEVE AND LOUVER SIZE 24B - 30

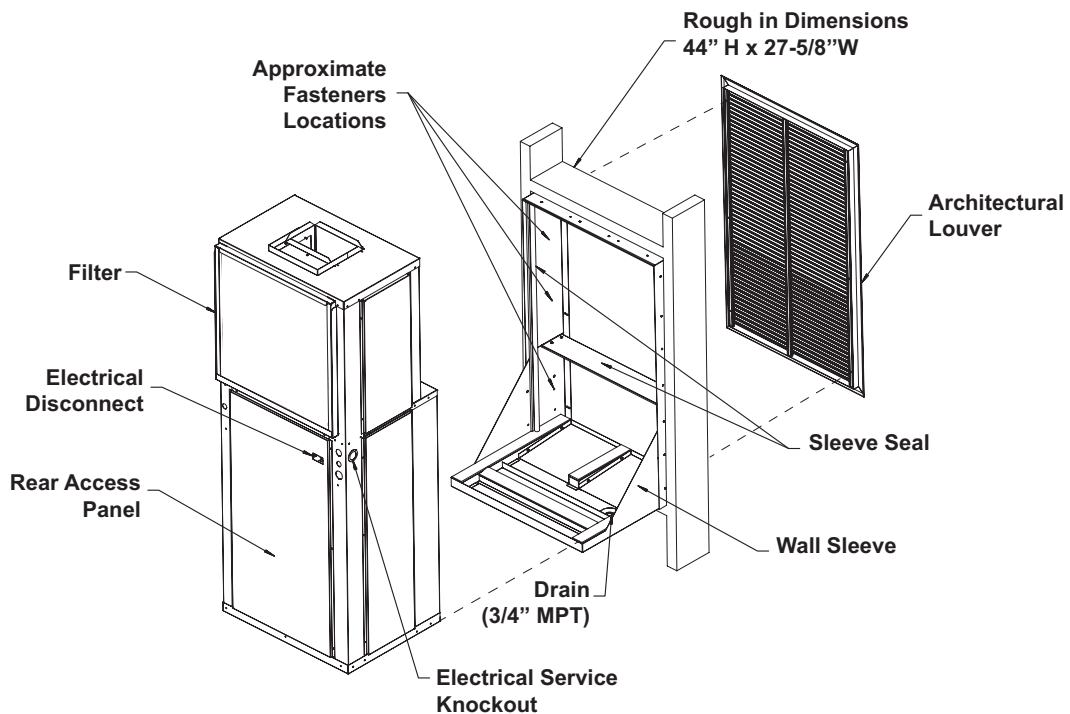

ECO SERIES COOL-PAK HP

SPACE CONSTRAINED HEAT PUMP W/ELECTRIC HEATING

GENERAL ASSEMBLY FOR LARGE SLEEVE AND LOUVER FOR 09 - 24A SIZES WITH BLOCK OFF

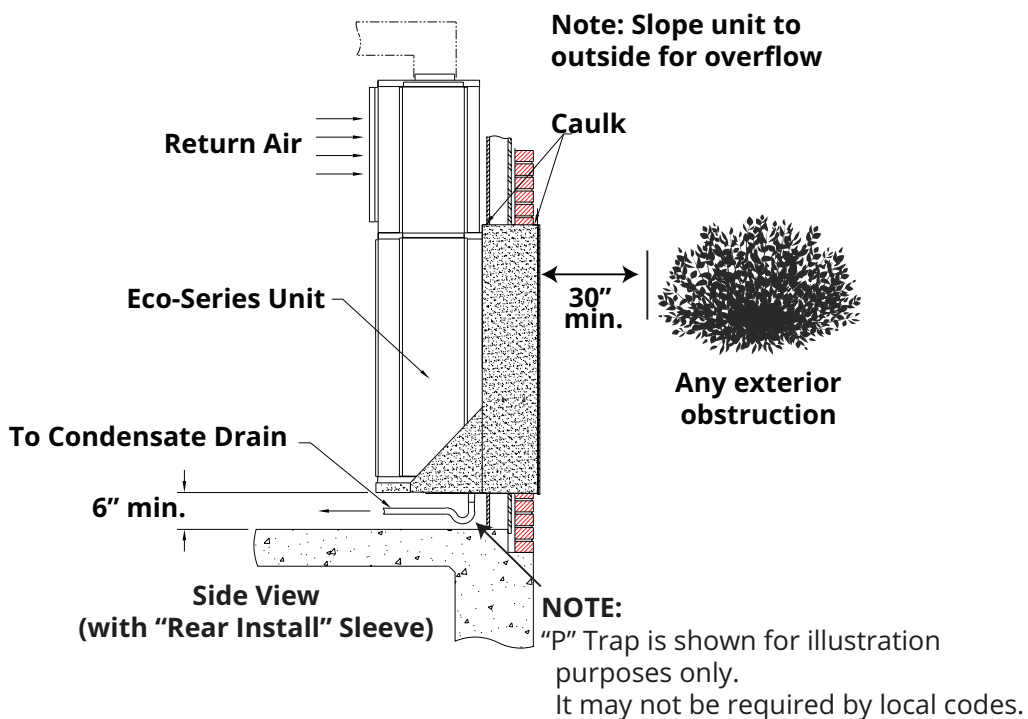
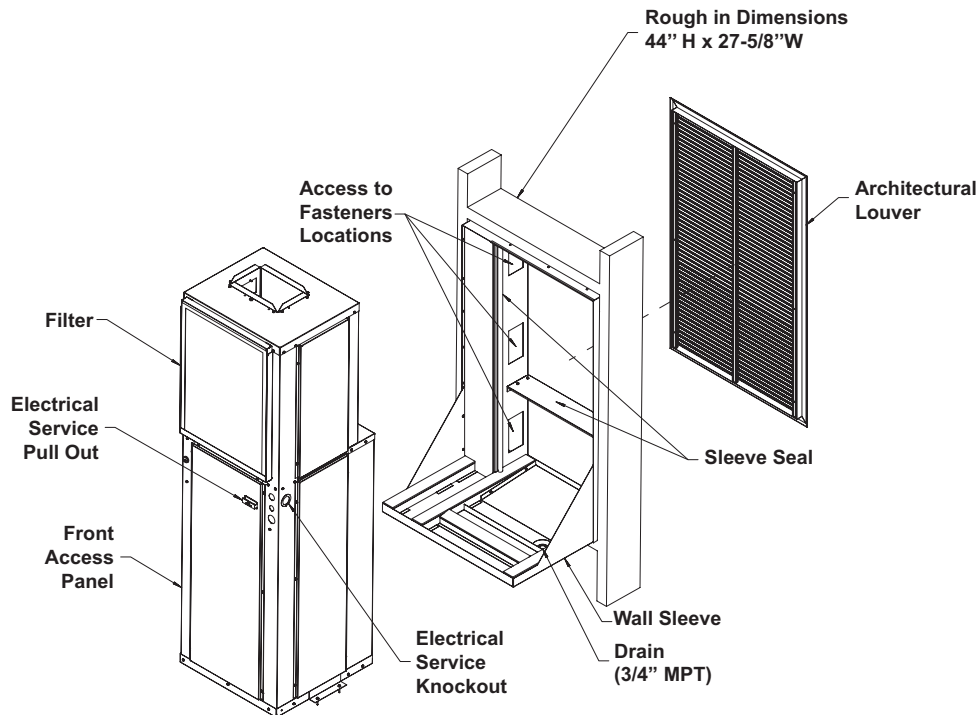

ECO SERIES COOL-PAK HP

SPACE CONSTRAINED HEAT PUMP W/ELECTRIC HEATING

CLOSET DIMENSIONS

NOTES:

1. Sleeve rough-in opening is 44"(H) X 21-5/8"(W).
2. Bottom of opening should be approx. 6" above floor level.
3. Minimum 3" of clearance is required on all sides of the unit.
4. Note Wind Resistant Louver is 3/4" larger

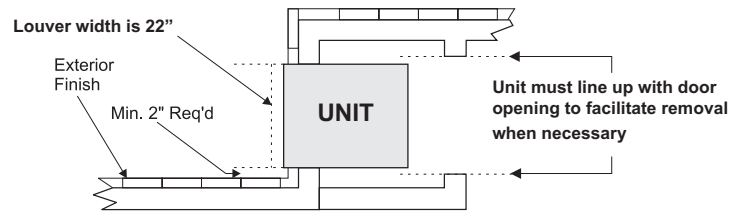

REAR INSTALLATION DETAIL FOR SMALL SLEEVE 21" WIDE (9-24A ONLY)

INSTRUCTIONS:

To find the minimum closet depth (dimension "C"), use the following method:

Determine dimension "A" which is the total finished wall thickness.

- For 5"-8" outside wall thickness, subtract "A" from 29". ("C" = 29 - "A")
- For 8"-12" outside wall thickness, subtract "A" from 33". ("C" = 33 - "A")
- For 12"-15" outside wall thickness, subtract "A" from 36". ("C" = 36 - "A")

NOTE: Provide minimum clearances as shown for interior closet dimensions.

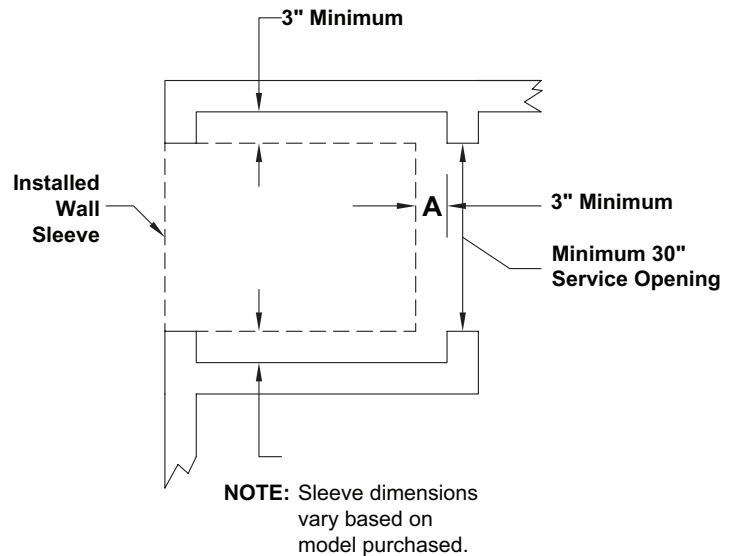

REAR INSTALLATION DETAIL FOR LARGE SLEEVE 27" WIDE (24B, 30 SIZE OR 9-24A WITH BLOCKOFF)

Notes:

1. Sleeve rough-in opening is 44"(H) X 27-5/8"(W).
2. Bottom of opening should be approx. 6" above floor level.
3. Minimum 3" of clearance is required on all sides of the unit.
4. Note Wind Resistant Louver is 3/4" larger

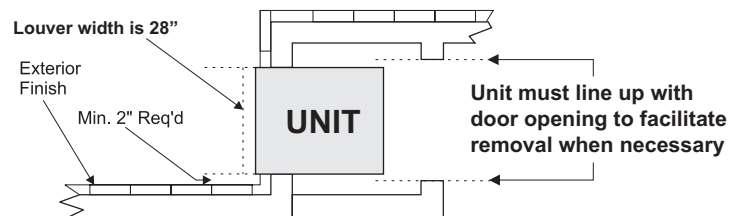

ECO SERIES COOL-PAK HP

SPACE CONSTRAINED HEAT PUMP W/ELECTRIC HEATING

CLOSET DIMENSIONS (CONT'D)

REAR INSTALLATION DETAIL FOR LARGE SLEEVE 27" WIDE (24B, 30 SIZE OR 9-24A WITH BLOCKOFF)

INSTRUCTIONS:

To find the minimum closet depth (dimension "C"), use the following method:

Determine dimension "A" which is the total finished wall thickness.

- For 5"-8" outside wall thickness, subtract "A" from 39". ("C" = 39 - "A")
- For 8"-12" outside wall thickness, subtract "A" from 43". ("C" = 43 - "A")
- For 12"-15" outside wall thickness, subtract "A" from 46". ("C" = 46 - "A")

NOTE: Provide minimum clearances as shown for interior closet dimensions.

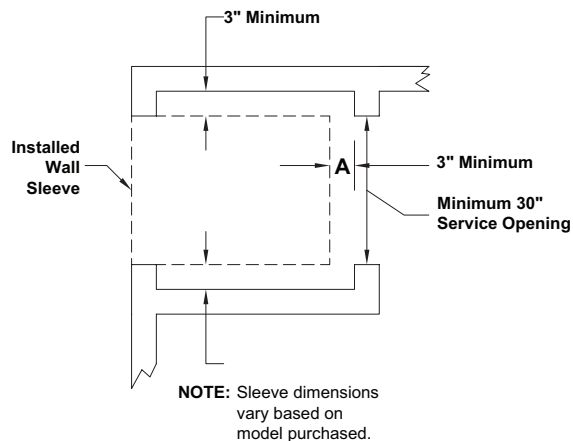

SIDE INSTALLATION DETAIL FOR SMALL SLEEVE 21" WIDE (9-24A SIZE ONLY)

NOTES:

1. Sleeve rough-in opening is 44"(H) X 21-5/8"(W).
2. Bottom of opening should be approx. 6" above floor level.
3. Minimum 3" of clearance is required on all sides of the unit and 12" clearance on the rear.

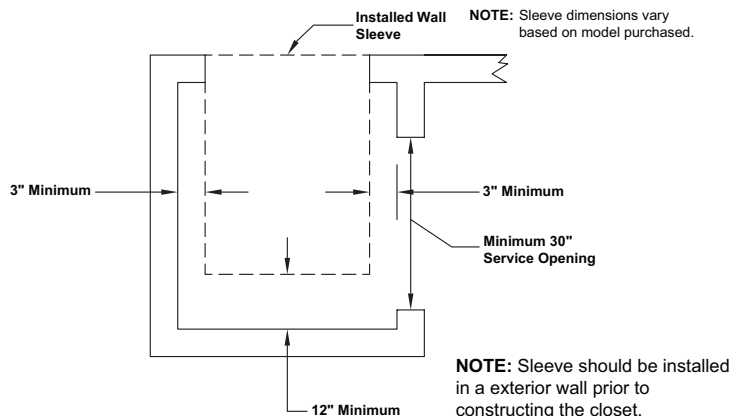

SIDE INSTALLATION DETAIL FOR SMALL SLEEVE 27" WIDE (24B, 30 SIZE OR 9-24A WITH BLOCK OFF)

NOTES:

1. Sleeve rough-in opening is 44"(H) X 21-5/8"(W).
2. Bottom of opening should be approx. 6" above floor level.
3. Minimum 3" of clearance is required on all sides of the unit and 12" clearance on the rear.

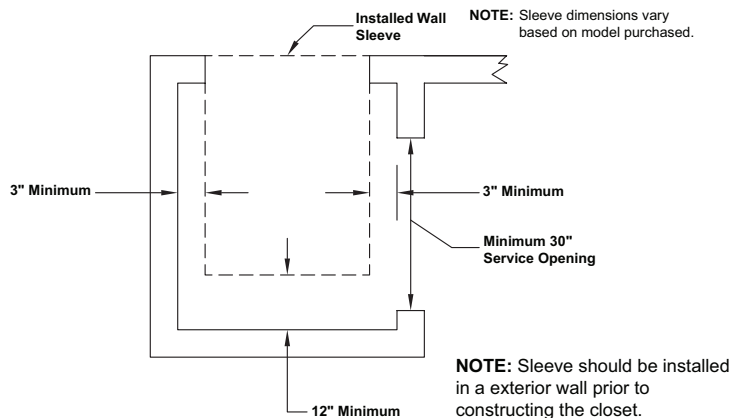



AMERICAN MADE. FAMILY OWNED.



FIRST CO.
P.O. BOX 270969 - DALLAS, TEXAS 75227
PH. (214) 388-5751 | FAX (214) 388-2255
WWW.FIRSTCO.COM

MARCH 2026