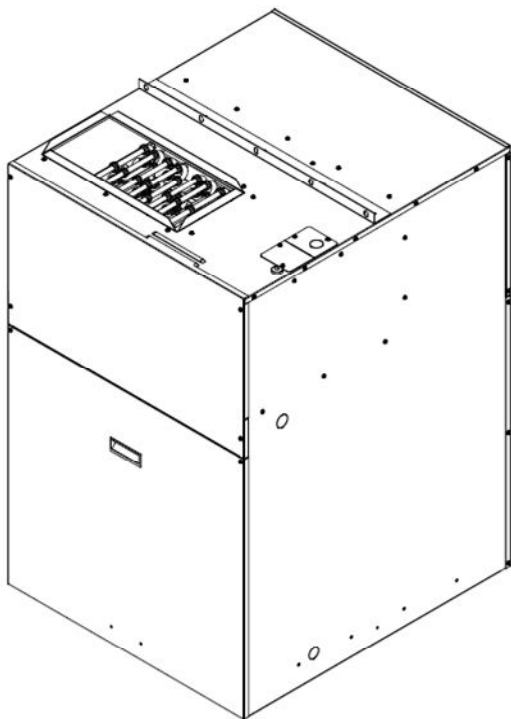


# Installation, Operation, & Maintenance Manual

IOM8404  
Rev. E 1/24

## FPH SERIES Vertical Packaged Heat Pump Unit W/Electric Heat



### ATTENTION:

#### Installer

Read this manual before starting installation.  
Affix these instructions on or adjacent to the heat pump.

#### Consumer

Read these instructions thoroughly and retain all manuals for future reference.



Intertek

## COPYRIGHT

First Co. works to continuously improve its products and as a result, it reserves the right to change design and specifications without notice.

The warranty may be void unless the Startup & Performance Checklist is completed and returned to the warrantor. If the FIRST-PAK FPH is not installed properly, the warranty will be void, as the manufacturer cannot be held accountable for problems that stem from improper installation.

©2021 First Co., 8273 Moberly Lane, Dallas, TX 75227

**\*\*\*WARNING TO INSTALLER, SERVICE PERSONNEL AND OWNER\*\*\***

Altering the product or replacing parts with non-authorized factory parts voids all warranty or implied warranty and may result in adverse operational performance and/or a possible hazardous condition to service personnel and occupants. Company employees and/or contractors are not authorized to waive this warning.

# TABLE OF CONTENTS

SAFETY CONSIDERATIONS	4-5
MODEL NOMENCLATURE	6
UNIT DIMENSIONAL DATA	7
UNIT PHYSICAL DATA	8
ELECTRICAL DATA	9
RATING COOLING AND HEATING PERFORMANCE	9
GENERAL INFORMANTION	10
INTRODUCTION	10
STORAGE	11
SHIPPING AND PACKAGING LIST	11
UNIT INSPECTION CHECKLIST	12
INSTALLATION	13-20
REQUIREMENTS	13
INSTALLATION PRECAUTIONS	13
UNIT LOCATION	13
UNIT CLEARANCE REQUIREMENTS	14
WALL SLEEVE INSTALLATION	15
UNIT SUPPORT	16
PACKAGED UNIT INSTALLATION	17-18
DUCTWORK	19
CONDENSATE DRAINAGE	19
AIR FILTER	20
FIELD WIRING	20-21
WIRING DIAGRAMS	22-25
STARTUP INSTRUCTIONS	26
UNIT OPERATIONS	27-29
BLOWER PERFORMANCE	30-31
MAINTENANCE & SERVICE – ELECTRIC HEAT	32-33
MAINTENANCE & SERVICE – HEAT PUMP SYSTEM	33-35
STARTUP & PERFORMANCE CHECKLIST	36-37
NOTES	38
Pre-Installed Drain Pan Heater Kit – Wiring Harness 9KFPDH-01	Contact Factory

## SAFETY CONSIDERATIONS



### 1. READ THE ENTIRE MANUAL BEFORE STARTING THE INSTALLATION.

2. These instructions are intended as a general guide and do not supersede national, state, or local codes in any way.
3. Altering the product, improper installation, or the use of unauthorized factory parts voids all warranty or implied warranty and may result in adverse operation and/or performance or may result in hazardous conditions to service personnel and occupants. Company employees or contractors are not authorized to waive this warning.
4. This product should only be installed and serviced by a qualified, licensed installer or service agency.
5. All kits and accessories used must be factory authorized when modifying this product. Refer and follow instructions packaged with the kits or accessories when installing.

## RECOGNIZE THE FOLLOWING SAFETY NOTATIONS THROUGHOUT THIS MANUAL AND POSTED ON THE EQUIPMENT:

	<b>DANGER</b>	
Indicates an imminently hazardous situation which, if not avoided, will result in death or serious injury.		

	<b>WARNING</b>	
Indicates a potentially hazardous situation or unsafe practices that could result in severe personal injury or death and/or damage to property.		

	<b>WARNING</b>	
	<b>ELECTRIC SHOCK HAZARD</b>	
This warning signifies potential electrical shock hazards that could result in personal injury or death.		

	<b>CAUTION</b>	
The CAUTION symbol indicates a potentially hazardous situation that may result in minor or moderate injury.		

	<b>IMPORTANT</b>	
Suggests important procedure steps to insure proper installation, reliability, or operation.		

	<b>NOTE</b>	
Used to highlight suggestions, which may result in enhanced installation, reliability or operation.		

	<b>WARNING</b>	
	<b>FIRE OR EXPLOSION HAZARD</b>	
Failure to follow safety warnings exactly could result in dangerous operation, serious injury, death or property damage.		
Improper servicing could result in dangerous operation, serious injury, death or property damage.		
<ul style="list-style-type: none"> <li>• Before servicing, disconnect all electrical power to the unit.</li> <li>• When servicing controls, label all wires prior to disconnecting. Reconnect wires correctly.</li> </ul>		
Verify proper operation after servicing.		

## SAFETY CONSIDERATIONS CONTINUED

### WARNING

Improper installation, adjustment, alteration, service, or maintenance can cause property damage, personal injury or loss of life. Refer to the user's information manual provided with this unit. Installation and materials, service must be performed by a qualified installer, service agency.



### WARNING

Installation and service must be performed by a licensed professional installer (or equivalent), service agency. Attempting to install or repair this unit without such background may result in product damage, personal injury or death.

### WARNING

These instructions are intended as an aid to qualified, licensed service personnel for proper installation, adjustment and operation of this unit. Read these instructions thoroughly before attempting installation or operation. Failure to follow these instructions may result in improper installation, adjustment, service or maintenance possibly resulting in fire, electrical shock, property damage, personal injury or death.

### WARNING

 **HIGH VOLTAGE!**   
Disconnect all power before servicing. Failure to do so may result in property damage, personal injury, or death.

### CAUTION

Use care when handling compressors. Some temperatures could be hot!

### CAUTION

Compressors should not be used to evacuate the air conditioning system. Vacuums this low can cause internal electrical arcing resulting in a damaged or failed compressor.

### WARNING

The unit must be permanently grounded. Failure to do so can cause electrical shock resulting in severe personal injury or death.

### WARNING

**USE COPPER SUPPLY WIRES ONLY!**

# MODEL NOMENCLATURE

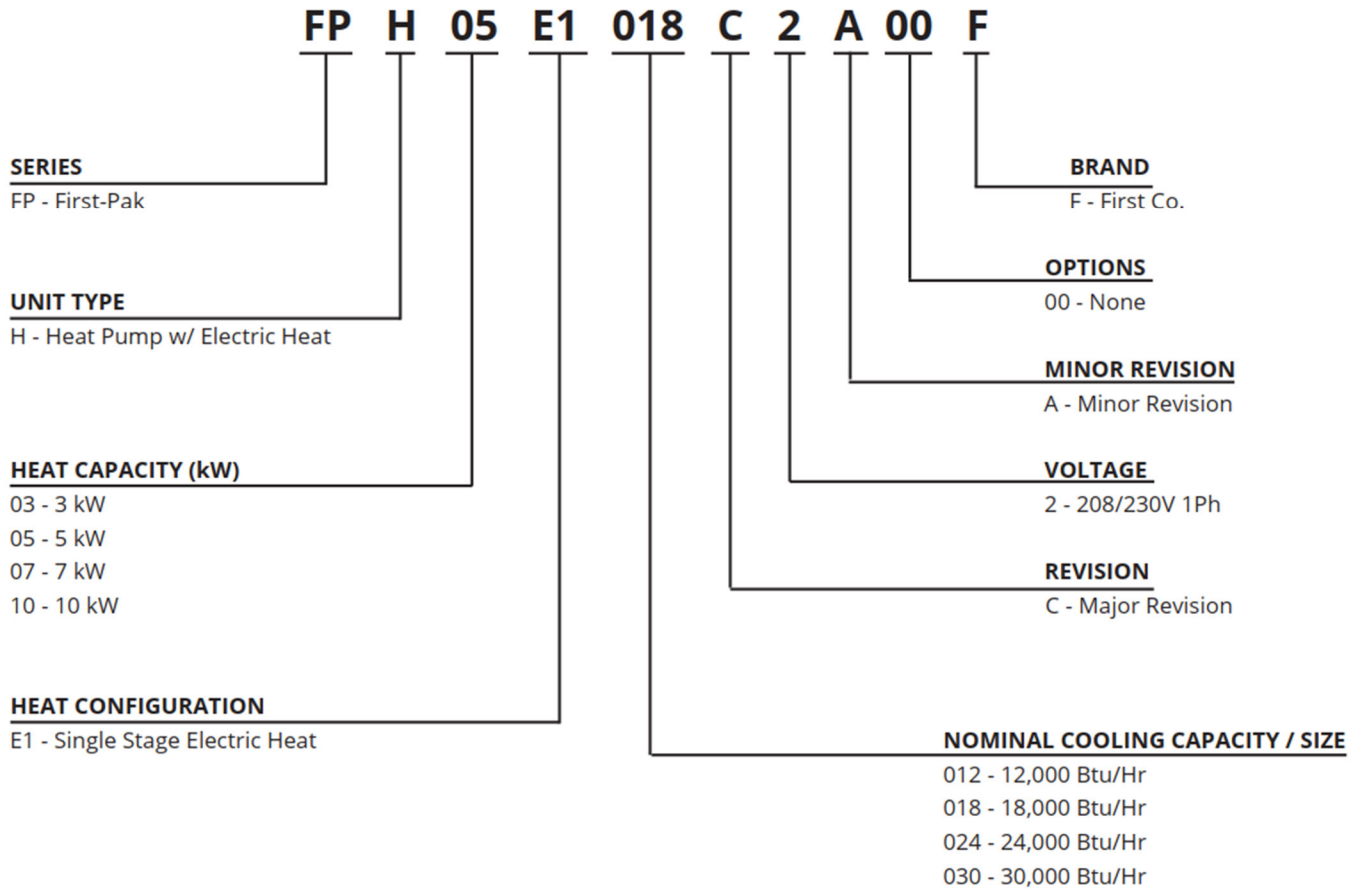


FIGURE 1 - MODEL NOMENCLATURE

# UNIT DIMENSIONAL DATA

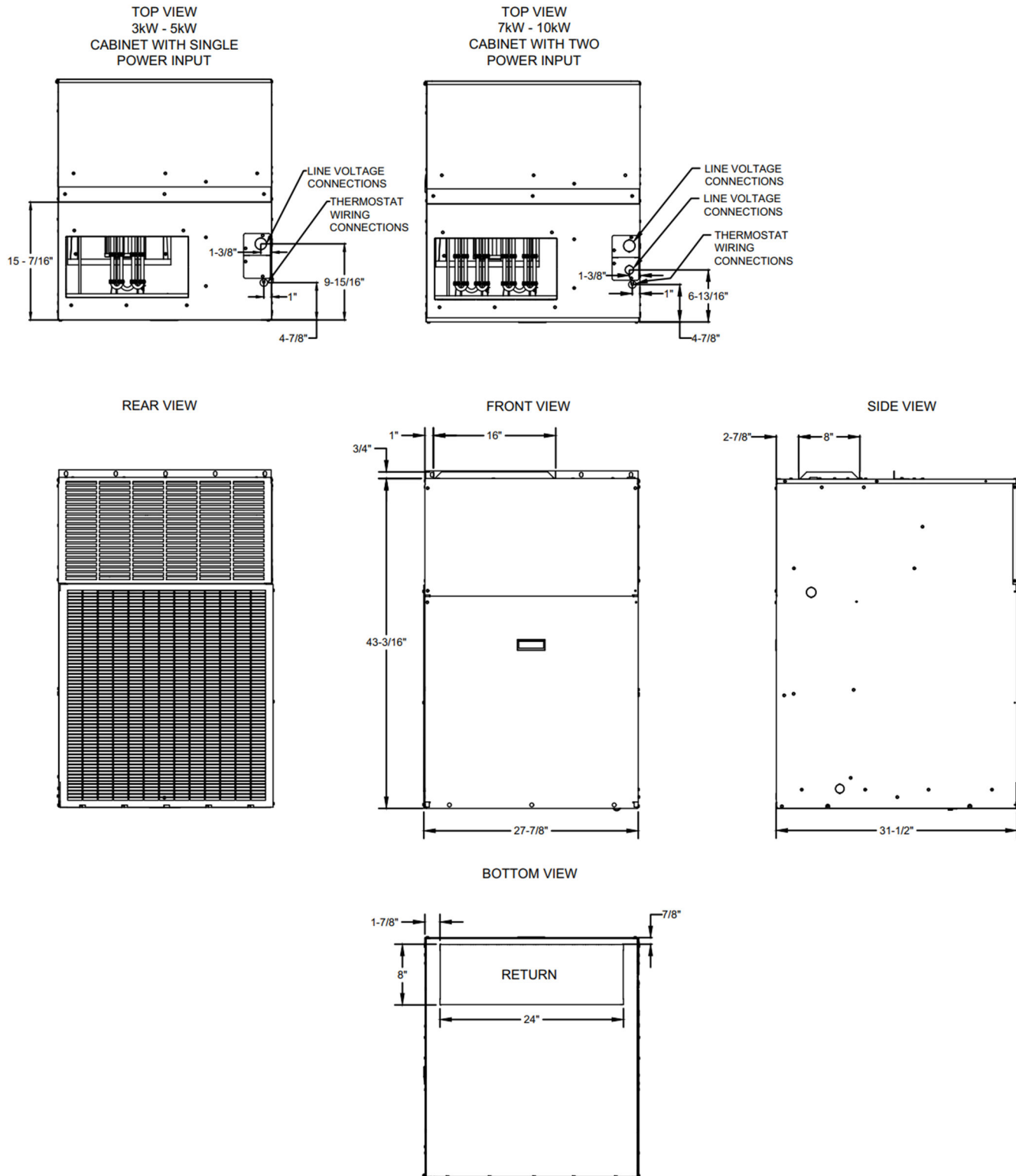


FIGURE 2 - Unit Dimensions

# UNIT PHYSICAL DATA

FPH MODEL	FPH03E1012C	FPH05E1012C	FPH07E1012C	FPH05E1018C	FPH07E1018C	FPH10E1018C
Compressor Type (Qty)	Rotary (1)	Rotary (1)	Rotary (1)	Scroll (1)	Scroll (1)	Scroll (1)
Factory Charge (R410A) lbs. [kg]	3.76 [1.71]	3.76 [1.71]	3.76 [1.71]	5.9 [2.68]	5.9 [2.68]	5.9 [2.68]
Compressor Capacitor	40MFD/370V	40MFD/370V	40MFD/370V	30MFD/370V	30MFD/370V	30MFD/370V
Condenser Fan HP [kW]	1/5 [.15]	1/5 [.15]	1/5 [.15]	1/3 [.25]	1/3 [.25]	1/3 [.25]
Indoor Fan HP [kW]	1/4 [.17]	1/4 [.17]	1/4 [.17]	1/3 [.25]	1/3 [.25]	1/3 [.25]
Blower Size (D x W) in. [cm]	10 x 6 [25.4 x 15.24]					
Condenser Coil Dimensions (H x W) in. [cm]	26.46 x 22.25 [67.2 x 56.5]					
Evaporator Coil Dimensions (H x W) in. [cm]	23.15 x 22.25 [58.8 x 56.5]			24 x 22 [60.96 x 55.88]		
Filter Size (H x W) in. [cm]	24 x 24 [60.96 x 60.96]					
Electric Heater kW @240V	3.0	5.0	7.0 (2 - 3.5)	5.0	7.0 (2 - 3.5)	10.0 (2 - 5.0)
Max. External Static Pressure in. w.c. [pa]	0.5 [125]					
Operating Weight lbs. [kg]	265 [120]	265 [120]	266 [121]	299 [136]	301 [136]	301 [136]
Shipping Weight lb. [kg]	294 [133]	294 [133]	295 [134]	328 [149]	330 [149]	330 [149]

Table 1

FPH MODEL	FPH05E1024C	FPH07E1024C	FPH10E1024C	FPH05E1030C	FPH07E1030C	FPH10E1030C
Compressor Type (Qty)	Scroll (1)	Scroll (1)	Scroll (1)	Scroll (1)	Scroll (1)	Scroll (1)
Factory Charge (R410A) lbs. [kg]	5.5 [2.49]	5.5 [2.49]	5.5 [2.49]	4.5 [2.04]	4.5 [2.04]	4.5 [2.04]
Compressor Capacitor	35MFD/370V	35MFD/370V	35MFD/370V	40MFD/370V	40MFD/370V	40MFD/370V
Condenser Fan HP [kW]	1/3 [.25]	1/3 [.25]	1/3 [.25]	1/3 [.25]	1/3 [.25]	1/3 [.25]
Indoor Fan HP [kW]	1/2 [.37]	1/2 [.37]	1/2 [.37]	1/2 [.37]	1/2 [.37]	1/2 [.37]
Blower Size (D x W) in. [cm]	10 x 6 [25.4 x 15.24]					
Condenser Coil Dimensions (H x W) in. [cm]	26.46 x 22.25 [67.2 x 56.5]					
Evaporator Coil Dimensions (H x W) in. [cm]	24 x 22 [60.96 x 55.88]					
Filter Size (H x W) in. [cm]	24 x 24 [60.96 x 60.96]					
Electric Heater kW @240V	5.0	7.0 (2 - 3.5)	10.0 (2 - 5.0)	5.0	7.0 (2 - 3.5)	10.0 (2 - 5.0)
Max. External Static Pressure in. w.c. [pa]	0.5 [125]					
Operating Weight lbs. [kg]	305 [138]	306 [139]	306 [139]	306 [139]	308 [140]	308 [140]
Shipping Weight lbs. [kg]	334 [151]	335 [152]	335 [152]	335 [152]	337 [153]	337 [153]

Table 2

\*Data is subject to change. Please verify most current information on [www.firstco.com](http://www.firstco.com) or [www.AE-Air.com](http://www.AE-Air.com) websites.



# ELECTRICAL DATA

MODEL NUMBER	VOLTAGE-PH-HZ	COMPRESSOR		CONDENSER MOTOR		INDOOR MOTOR		MIN. CIRCUIT AMPACITY (MCA)				MAX. OVERCURRENT PROTECTION (MOP)				MIN. VOLTAGE	MAX. VOLTAGE
		RLA	LRA	FLA	HP	RLA	HP	CIRCUIT 1* (L1-L2)		CIRCUIT 2* (L3-L4)		CIRCUIT 1* (L1-L2)		CIRCUIT 2* (L3-L4)			
								240V	208V	240V	208V	240V	208V	240V	208V		
FPH03E1012C*	208/230-1-60	4.7	26.0	1.9	1/5	2.3	1/4	25.7	23.6	-	-	30	25	-	-	197	252
FPH05E1012C*	208/230-1-60	4.7	26.0	1.9	1/5	2.3	1/4	36.1	32.6	-	-	40	35	-	-	197	252
FPH07E1012C*	208/230-1-60	4.7	26.0	1.9	1/5	2.3	1/4	46.5	41.7	-	-	50	45	-	-	197	252
FPH05E1018C*	208/230-1-60	9.0	56.3	2.8	1/3	2.8	1/3	42.9	39.4	-	-	45	40	-	-	197	252
FPH07E1018C*	208/230-1-60	9.0	56.3	2.8	1/3	2.8	1/3	36.5	31.6	16.9	16.9	40	35	25	25	197	252
FPH10E1018C*	208/230-1-60	9.0	56.3	2.8	1/3	2.8	1/3	52.1	45.1	16.9	16.9	60	50	25	25	197	252
FPH05E1024C*	208/230-1-60	10.7	55.0	2.8	1/3	4.1	1/2	46.3	42.8	-	-	50	45	-	-	197	252
FPH07E1024C*	208/230-1-60	10.7	55.0	2.8	1/3	4.1	1/2	36.5	31.6	20.3	20.3	40	35	30	30	197	252
FPH10E1024C*	208/230-1-60	10.7	55.0	2.8	1/3	4.1	1/2	52.1	45.1	20.3	20.3	60	50	30	30	197	252
FPH05E1030C*	208/230-1-60	11.7	71.3	2.8	1/3	4.1	1/2	47.6	44.1	-	-	50	50	-	-	197	252
FPH07E1030C*	208/230-1-60	11.7	71.3	2.8	1/3	4.1	1/2	36.5	31.6	21.5	21.5	40	35	30	30	197	252
FPH10E1030C*	208/230-1-60	11.7	71.3	2.8	1/3	4.1	1/2	52.1	45.1	21.5	21.5	60	50	30	30	197	252

Table 3

\*. Circuit 1 and circuit 2 are separated power wires connecting to the unit. Refer to wiring diagram for details.

. Wire size should be determined in accordance with National Electrical Codes.

## RATED COOLING AND HEATING PERFORMANCE

Model	COOLING				HEATING		ELECTRIC HEAT			
	Net Capacity (Btu/h)	EER2	SEER2	S/T*	Net Capacity (Btu/h) 47°F	HSPF2	240V		208V	
							kW	Btu/h	kW	Btu/h
FPH03E1012C*	10,800	10.5	11.9	0.86	10,900	6.3	3.0	10,236	2.3	7,688
5.0							17,060	3.8	12,814	
7.0							23,884	5.3	17,940	
FPH05E1018C*	16,500	10.0	11.9	0.85	16,000	6.3	5.0	17,060	3.8	12,814
7.0							23,884	5.3	17,940	
10.0							34,120	7.5	25,628	
FPH05E1024C*	22,800	10.0	11.9	0.77	21,800	6.3	5.0	17,060	3.8	12,814
7.0							23,884	5.3	17,940	
10.0							34,120	7.5	25,628	
FPH05E1030C*	26,200	10.0	11.9	0.78	24,000	6.3	5.0	17,060	3.8	12,814
7.0							23,884	5.3	17,940	
10.0							34,120	7.5	25,628	

Table 4

\*Unit is rated at 0.3" external static

\*All units tested to AHRI 210/240 2023(2020)

\*Data is subject to change. Please verify most current information on [www.firstco.com](http://www.firstco.com) or [www.AE-Air.com](http://www.AE-Air.com) websites.

## GENERAL INFORMATION



### CAUTION



DO NOT use these units as a source of heating or cooling during the construction process. Mechanical components and filters can become clogged with dirt and debris, which can cause damage to the system.

The manufacture does not warrant equipment subjected to abuse.



### WARNING



#### ELECTRIC SHOCK HAZARD



Before servicing equipment, ALWAYS turn off all power to the unit. There may be more than one disconnect switch. Electrical shock can cause injury or death.

Clear surrounding area of all tools, equipment, and debris before operating this unit.

These instructions are provided for the installation of the FIRST-PAK FPH heat pump specifically. For any other related equipment, refer to the appropriate manufacturer's instructions.



### WARNING



This heat pump is certified for through-the-wall indoor installation only. This heat pump is **NOT** approved for mobile homes, recreational vehicles or outdoor applications. Such use could result in property damage, personal injury, or death.



### CAUTION



This heat pump must never be operated under any circumstances without an air filter in place.



### NOTE



Material in this shipment has been inspected at the factory and released to the transportation agency in good condition. When received, a visual inspection of all cartons should be made immediately. Any evidence of rough handling or apparent damage should be noted on the delivery receipt in the presence of the carrier's representative. If damage is found, a claim should be immediately filed against the carrier.

This heat pump is designed for through-the-wall indoor installation only. Installation of this equipment, wiring, ducts, and any related components must conform to current agency codes, state laws, and local codes. Such regulations take precedence over general instructions contained in this manual.



### CAUTION



Extreme caution must be taken that no internal damage will result from screws that are drilled into the cabinet.

## INTRODUCTION

The FIRST-PAK FPH heat pumps are self-contained packaged unit with supplemental electric heater for space constrained application. The unit design has been certified by Intertek Testing Services for compliance with the Standard of UL 1995 for Safety for Heating and Cooling Equipment. The FPH models are certified to be in compliance with the latest edition of AHRI Standard 210/240.

These installation instructions are intended as a general guide only, for use by an experienced, qualified contractor.

## STORAGE

Equipment should be stored in a clean dry, conditioned area with maximum temperatures up to 120°F [48.89°C] and minimum temperatures to 32°F [0°C]. Units should be stored upright and in an indoor environment. It is recommended to leave packaging on the unit until the installation is to begin.



### WARNING



Do not stack more than **FOUR** units for storage purposes. Failure to follow these instructions may result in damage to the unit, property damage, personal injury or death.

DO NOT operate these units during the construction process. Mechanical components and filters could become clogged with dirt and debris, which can cause damage to the system and unit not function properly.

The manufacture does not warrant equipment subjected to abuse.

## SHIPPING & PACKAGE LIST



### NOTE



Material in this shipment has been inspected at the factory and released to the transportation agency in good condition. When received, a visual inspection of all cartons should be made immediately. Any evidence of rough handling or apparent damage should be noted on the delivery receipt in the presence of the carrier's representative. If damage is found, a claim should be immediately filed against the carrier.

### SHIPPING INSTRUCTIONS

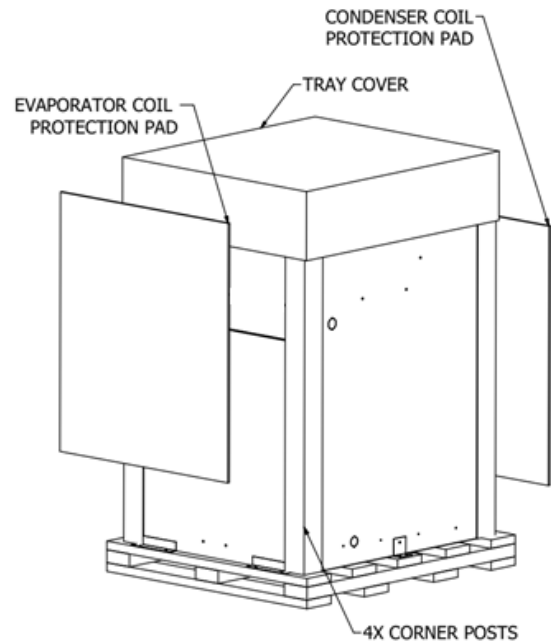
The FIRST-PAK FPH heat pumps must remain in the upright position throughout the shipping and handling process to maintain a proper level of oil in the compressor.



### NOTE



Shrink wrap is located around the unit for protection. Remove before installation.



Standard Packaging

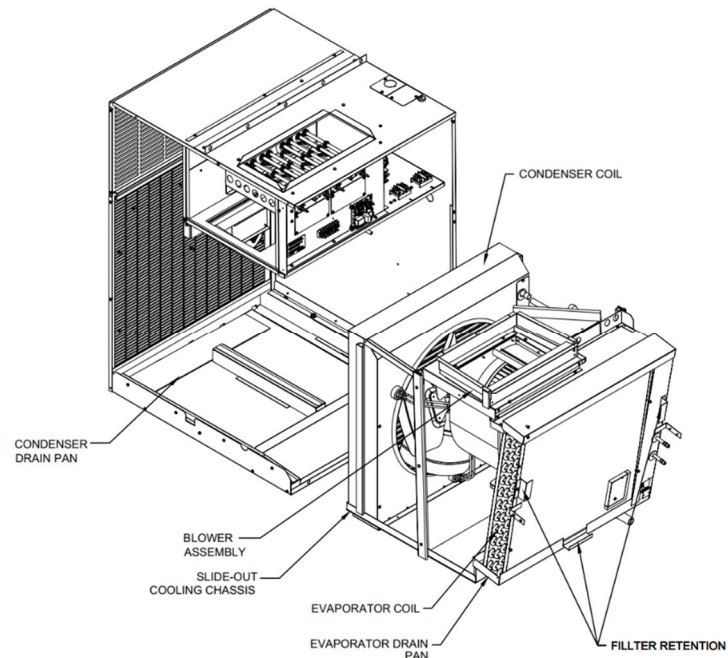
### PACKAGE LIST

The units will be shipped with the following items:

- 1- FIRST-PAK FPH heat pump unit:
  - A- Shipping bracket (4)
  - B- Screws (8)
  - C- Top mounting bracket
  - D- Screws (5)
- 2- Literature package
  - A- IOM - Installation & Operations Manual
  - B- Warranty certificate
- 3- Bushing #EW1063
  - A- Screw (1)

Check the unit for shipping damage; if found, immediately contact the last carrier.

# UNIT INSPECTION CHECKLIST



**FIGURE 3 – Chassis Major Components**

Complete the inspection procedures below before preparing unit for installation:

- 1) Visually inspect unit for any shipping damage. Damage must be reported immediately to the shipping company to make a claim.
- 2) Ensure that the carrier makes proper notation of any shortages or damage on all copies of the freight bill and completes a common carrier inspection report.
- 3) Verify that unit nameplates on the data label match the sales order or bill of lading (including, unit configuration, size and voltage).
- 4) Ensure that the shipping brackets and screws are removed from the chassis section. Refer to **FIGURE 4 - Standard Packaging with Shipping Brackets - Back View** & **FIGURE 5 – Standard Packaging with Shipping Brackets – Front View** for more information.
- 5) Immediately before installation, remove unit front access panels and verify that all electrical connections are tight and that there are no loose wires.
- 6) Check that the blower spins freely within the housing and that there are no obstructions between the wheel and housing. The wheel can sometimes come loose in shipping.
- 7) Inspect the electric heater section:
  - a. Check if there's any part damaged or loose.
  - b. Check to make sure all wiring connections are tight and there are no loose or broken wires.
  - c. Check if the insulation peels off

Slide out the cooling chassis, check to make sure that the refrigerant piping is free from any kinks, no visible refrigerant leak sign and there is no interference between unit piping and sheet metal or electrical wires. Refer to **FIGURE 3 – Chassis Major Components**

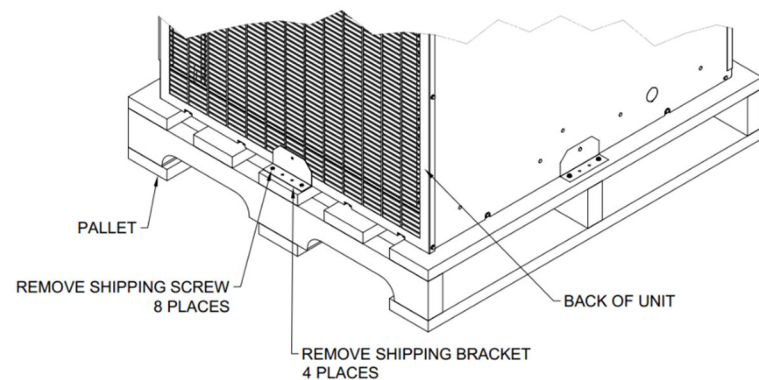
- 8) Check to make sure compressor mounting bolts and nuts are not loose.
- 9) Check to make sure the condenser fan blade rotates freely without hitting fan shroud.
- 10) Check the air-coil fins for any damage during shipping.
- 11) Drain line is not obstructed and is leak free.



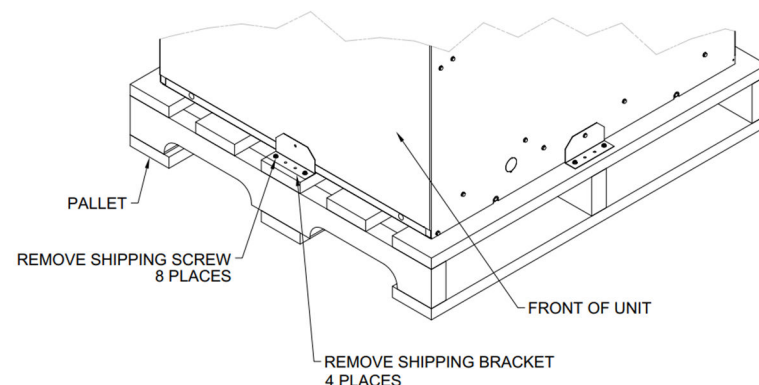
## NOTE



Check the unit nameplate for correct voltage with the plans before installing the equipment. Also, make sure all electrical ground connections are made in accordance with local code.



**FIGURE 4 - Standard Packaging with Shipping Brackets - Back View**



**FIGURE 5 – Standard Packaging with Shipping Brackets – Front View**

# INSTALLATION

## REQUIREMENTS

Follow manufacturer's installation instructions, as well as local and municipal building codes. In addition, the installation shall conform to the following National Fire Protection Association (NFPA) Standards:

- NFPA No. 90A – Standard for Installation of Air Conditioning and Ventilation Systems
- NFPA No. 90B – Standard for Installation of Residence Type Warm Air Heating and Air Conditioning Systems.

This unit is approved for installation clearance to combustible material as stated on the unit rating plate. However, stated minimum clearances to combustibles may be inadequate for future accessibility and service needs which must be considered prior to unit installation.

## INSTALLATION PRECAUTIONS

!

## CAUTION

!

Always wear all appropriate personal protection equipment when installing and servicing these units. Contact with metal edges and corners can result injury. Protective gloves should be worn when handling. Exercise caution when installing and servicing unit.

!

## WARNING

!

Use multiple people when moving and installing these units. Failure to do so could result in injury or death.

Observe the following precautions for typical installation:

- Always use proper tools and equipment
- No wiring or any work should be attempted without first ensuring the unit is completely disconnected from the power source and locked out. Also, verify that a proper permanent and uninterrupted, ground connection exists prior to energizing power to the unit.
- Review unit nameplate and wiring diagram for proper voltage and control configurations. This information may vary from unit to unit.

## UNIT LOCATION

This product is certified for through the wall, indoor, up-flow vertical position installation only. This appliance is not design certified for installation in mobile homes, recreational vehicles, or outdoors. A First Company approved wall sleeve must be used to install the unit.

Do not install directly on carpeting, tile, or other combustible material other than wood flooring.

The Installation must conform with local building codes or, in the absence of local codes, to the Protection Association Standards NFPA. No. 90A and NEPA. No. 90B.

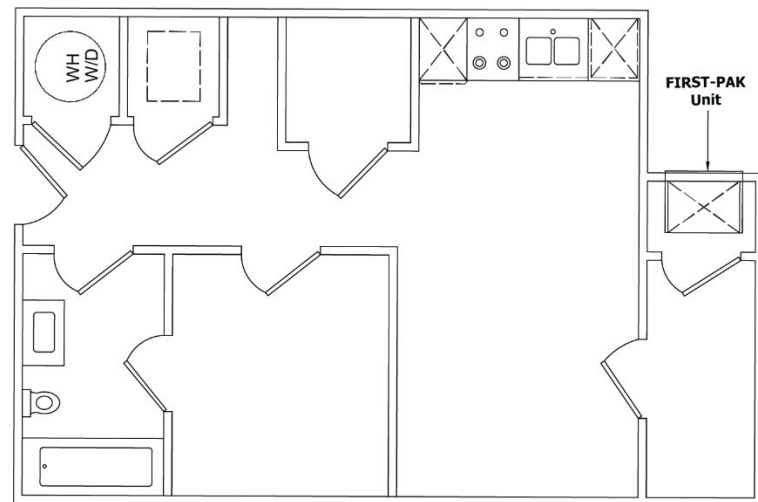


FIGURE 6 – Typical Floorplan with FIRST-PAK on Exterior Wall

**UNIT CLEARANCE REQUIREMENTS**

The interior of the unit may be installed with zero clearances to adjacent combustibles surfaces. Please check local codes.

Service clearance must be provided for future maintenance and service. A minimum of 32" [81.28cm] open area must be left unobstructed in front of the access panels.

The louver side must be kept free from any obstructions to air flow. The unit must be installed at least 4 feet [1.2192m] from electric meters, gas meters, regulators, and relief equipment.

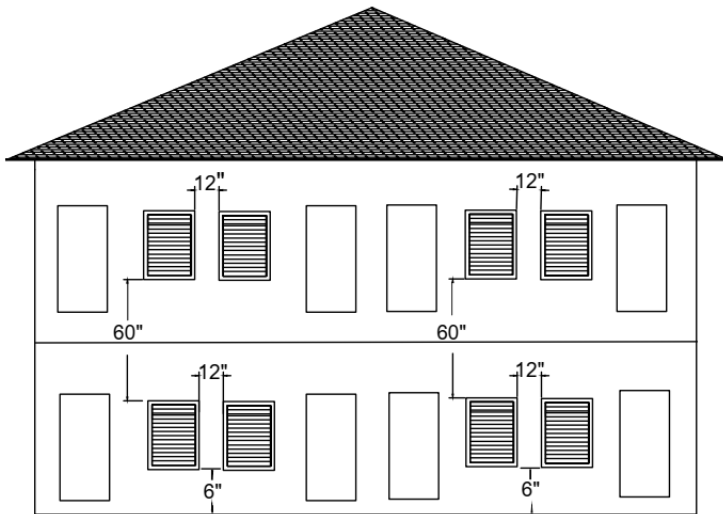


FIGURE 7 – Required Exterior Building Clearance

A heat pump installed in a garage must also be protected from damage by vehicles.

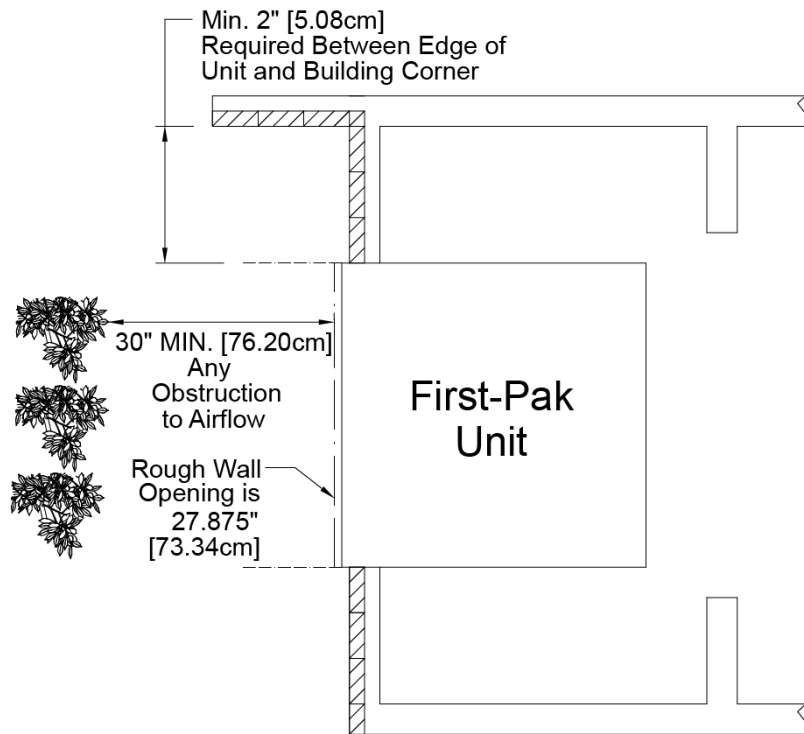


FIGURE 8 – Clearance Requirements

CLEARANCE REQUIREMENTS		
MINIMUM CLEARANCE	IN	CM
Horizontal distance between units	12	30
Vertical distance between units	60	152
Distance above ground level	6	15
Distance above finished floor	6	15
Distance above a garage floor	18	46
Distance to corner	2	5

Table 5- Exterior Clearance Requirements/Dimensions

**CAUTION**

A masonry wall opening must be properly constructed with a lintel for wall support. Wall openings must be flashed and sealed. The unit must be level, front to back and side to side.

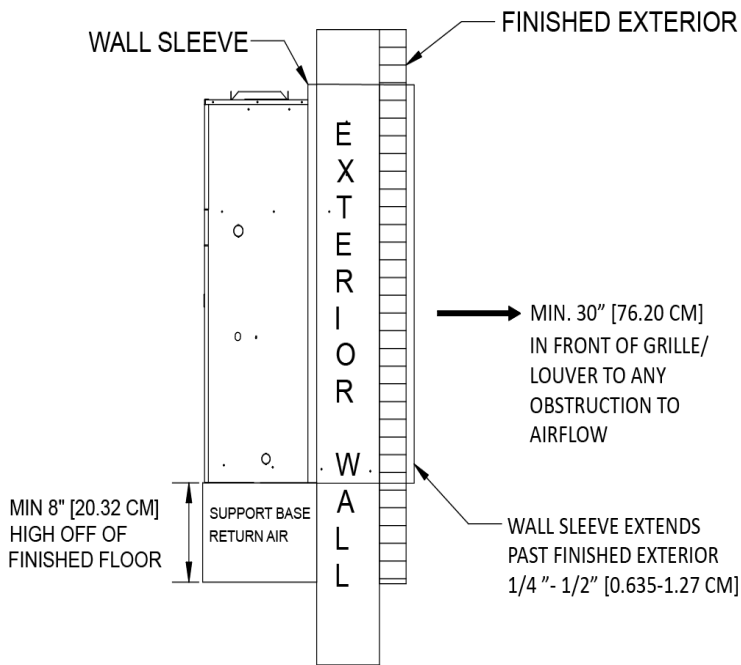
Refer to **CLEARANCE REQUIREMENTS** section in this manual for more information.

**WALL SLEEVE INSTALLATION**

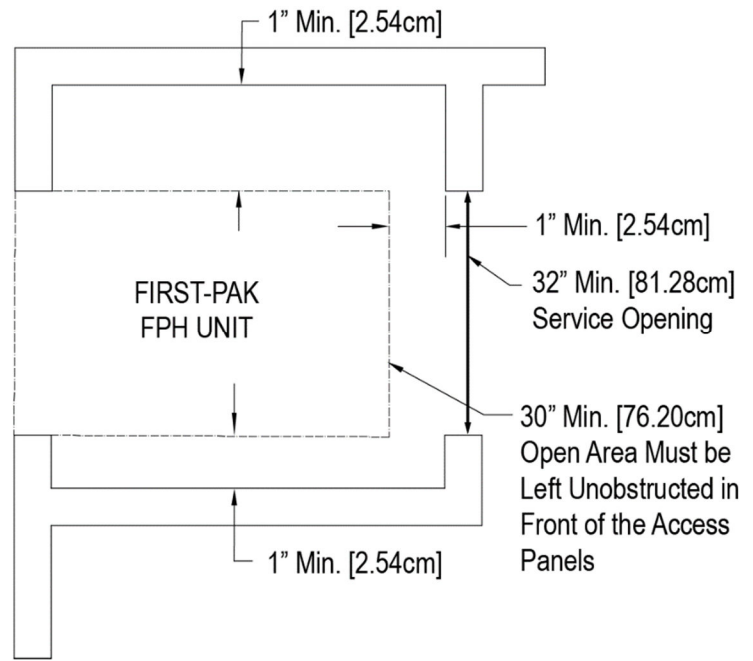
Refer to installation instruction packed with the wall sleeve to assemble and mount into the wall. Before unit installation, make sure sleeve components are not damaged.

Check all seals to ensure that they are in position and undamaged. Ensure that the wall sleeve is pitched toward the exterior of the building

**FIGURE 9 - Wall Sleeve Mounting** Securely fasten the Architectural louver grille to the front of the sleeve using the supplied hardware.




**FIGURE 9 - Wall Sleeve Mounting**




**FIGURE 10 – Interior Clearance Requirements/Dimensions**

The inside of the unit can be surrounded by a closet with minimum clearance to heater section match to 0" clearance on the sides, and 1" [2.54cm] from the front. Enough clearance should be provided for installing field wiring.



IMPORTANT



Make sure a high grade non-hardening sealant approved for exterior use has been applied between edge of the wall sleeve and the structure, on the inside and outside walls, to prevent air and water from migrating inside refer to **FIGURE 8 - Wall Sleeve Mounting**

## UNIT SUPPORT

The FIRST-PAK wall sleeve is not intended or designed to provide complete support for the FIRST-PAK unit. Additional support is required. A field constructed platform may be used for this purpose and may also be constructed to provide a means of attaching the return air duct.

## PLYWOOD INSTALLATION

Platform construction should be built as below in **FIGURE 11 - Unit Support & Alignment**. It must be fabricated with plywood, framing lumber and/or any pre-approved sheet metal construction material. **FIGURE 11 - Unit Support & Alignment** is showing alignment of the platform top with the base panel of the wall sleeve.

- Minimum height of platform = 8" [20.32cm]
- Recommended platform width = 29" [73.66cm]
- Recommended platform depth = 16" [40.64cm]

Refer to **FIGURE 11 - Unit Support & Alignment**.

Things to consider prior to constructing the platform:

1. Accurately measure the unit and choose a strong building material for the support structure.
2. It is recommended that for leveling purposes the unit should be well supported.
3. If additional vibration isolation material is required, non-combustible material **MUST** be used.
4. Ensure that the platform connection to FIRST-PAK Return Air Opening can fit an 8" x 24" [20.32cm x 60.96cm] duct. The FIRST-PAK unit must be aligned with return air opening on the unit base.
5. Ensure the support structure and the Wall Sleeve provide a secure, fixed, and leveled position. This allows a provision of bringing return air via ducting to the space under the unit.

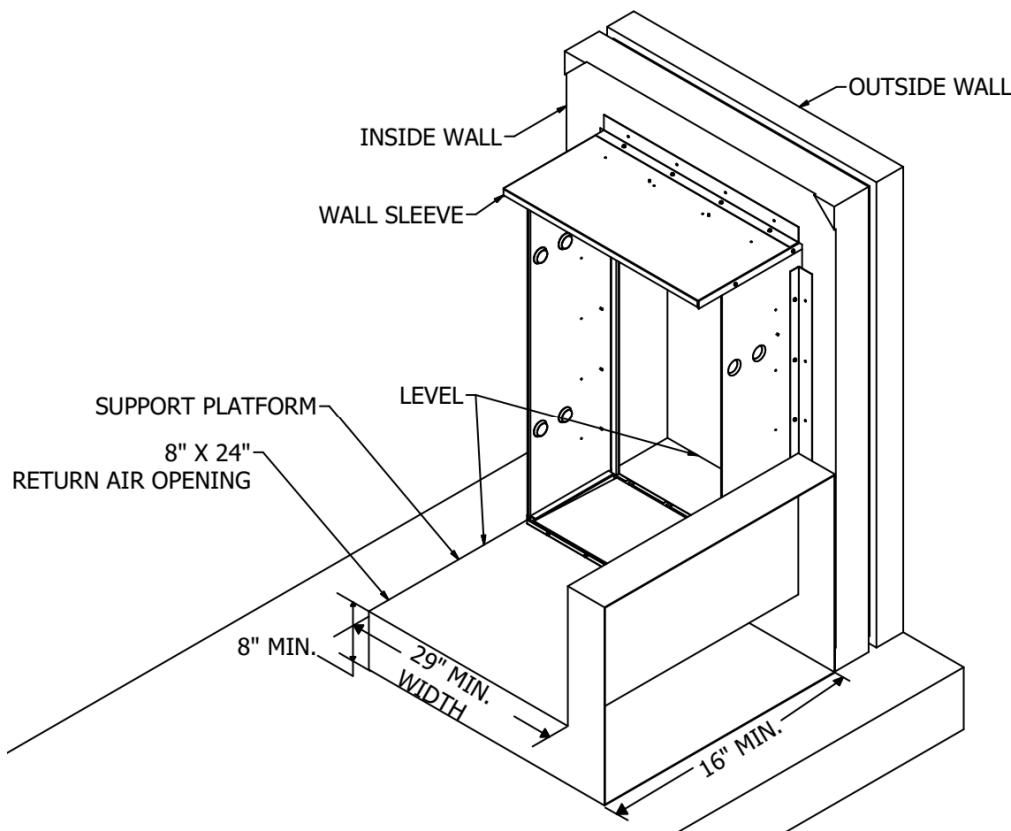




FIGURE 11 - Unit Support & Alignment



CAUTION



The wall sleeve is not intended as the sole support for the unit. An additional support must be provided near the return opening on the unit for adequate support. The use of vibration isolation material between the unit and the support is recommended.



**PACKAGED UNIT INSTALLATION****NOTE**

Locate the unit in an area that provides minimum clearance to all service access panels. Consider all additional clearances needed for water connections, electrical connections, duct connections and sufficient return airflow.

**IMPORTANT**

**These units are for indoor installation ONLY!**

**NOTE**

Do not locate unit in areas subject to freezing temperatures or where high humidity levels could cause cabinet condensation. Units should be mounted in the wall sleeve with a pitch to the outside of the building.

Insulation is installed on the indoor section of the unit to provide a barrier between outside air conditions surrounding the unit and the varying conditions inside the unit. If the insulating barrier is damaged, the surrounding ambient air will affect the inside surface temperature of the cabinet; this may lead to sheet metal corrosion and subsequently, component failure.

**IMPORTANT**

Damaged insulation must be repaired or replaced before the unit is placed back into operation. Insulation loses its insulating properties when wet, damaged, separated or torn.

The installer must adhere strictly to all local and national code requirements pertaining to the installation of this equipment including the cabinet, discharge plenum and connecting ducts. All units are designed for indoor use only, and are agency listed for installation with clearances specified on the product rating plate.

## PACKAGED UNIT INSTALLATION

**NOTE**

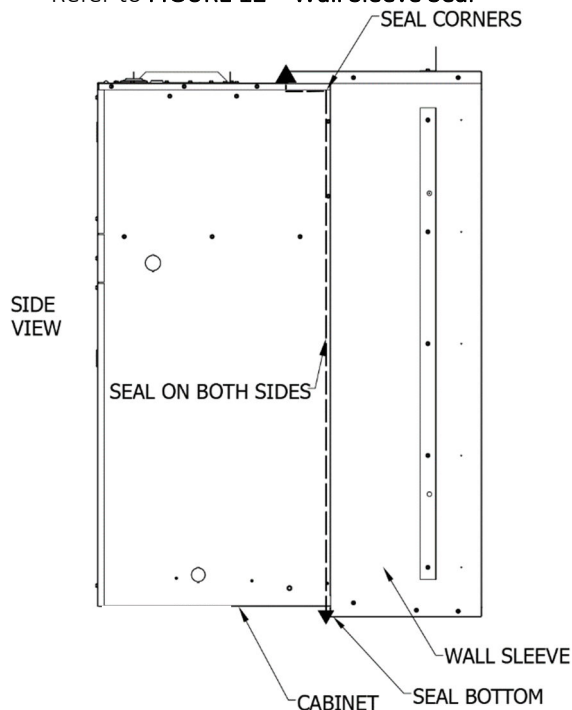
Check nameplate voltage, amperage and fuse size for proper power supply.

1. Remove the screws (8) and shipping brackets (4) holding the unit to the shipping pallet and remove unit from the shipping pallet.

**NOTE**

The top mounting bracket must be attached to the FIRST-PAK unit.

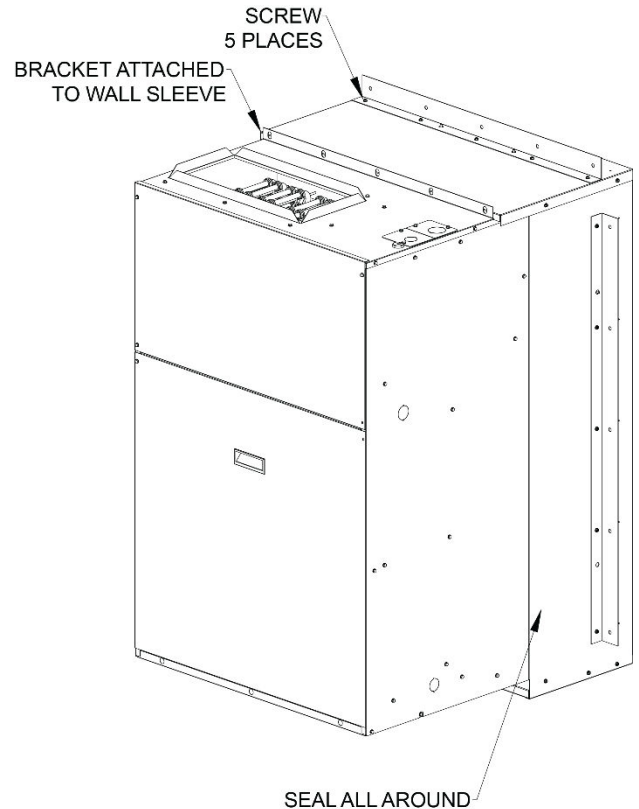
2. Attach the top mounting bracket to the unit with screws (5) provided with unit. Attach the wall sleeve retainer bracket to the unit top mounting bracket with screws (5) provided with wall sleeve. Refer to **FIGURE 12 – Wall Sleeve Seal**



**FIGURE 12 – Wall Sleeve Seal**

3. Ensure that properly sized ductwork is in place to mate to the connections on the FIRST-PAK.
4. Remove filter access panel, and slide out cooling chassis - check both blowers.
5. Inspect the filter provided with the unit. If dirty or damaged replace. (**Figure 16- Air Filter Location**) Place the filter into the filter bracket.
6. Ensure that the wall sleeve is installed squarely and is secured before installing the unit.

7. Inspect the sleeve seal, which is supplied with the sleeve, to ensure that it is properly secured and aligned refer to **FIGURE 12 – Wall Sleeve Seal**).
8. For shipping purposes, the supply flanges are shipped flat. The discharge duct flanges must be bent up at a 90° angle.
9. Slide the FIRST-PAK unit toward the sleeve seal until the sleeve and top mounting bracket are nested and almost making contact.
10. Center the FIRST-PAK unit in the wall sleeve.
11. Use screw fasteners to attach the top mounting bracket to wall sleeve.



**FIGURE 13 – Top Mounting Bracket Installation on Wall Sleeve**

12. Use a high grade non-hardening sealant to close any gaps that may exist between the seal and the wall of the sleeve.
13. Check that the unit is completely settled on all four sides against the wall sleeve gaskets.

**CAUTION**

If unit is not sealed properly, water and/or outside air will infiltrate into the closet, and can cause improper unit operation and may cause damage to the unit and/or property.

**DUCTWORK****IMPORTANT**

Supply and must be ducted to the unit.

**IMPORTANT**

The supply duct connection must be sized to a minimum of the same size as the unit discharge air opening.

**IMPORTANT**

All ductwork must be installed in accordance with National Fire Protection Assoc. NFPA Codes 90A and 90B.

**SUPPLY DUCTWORK**

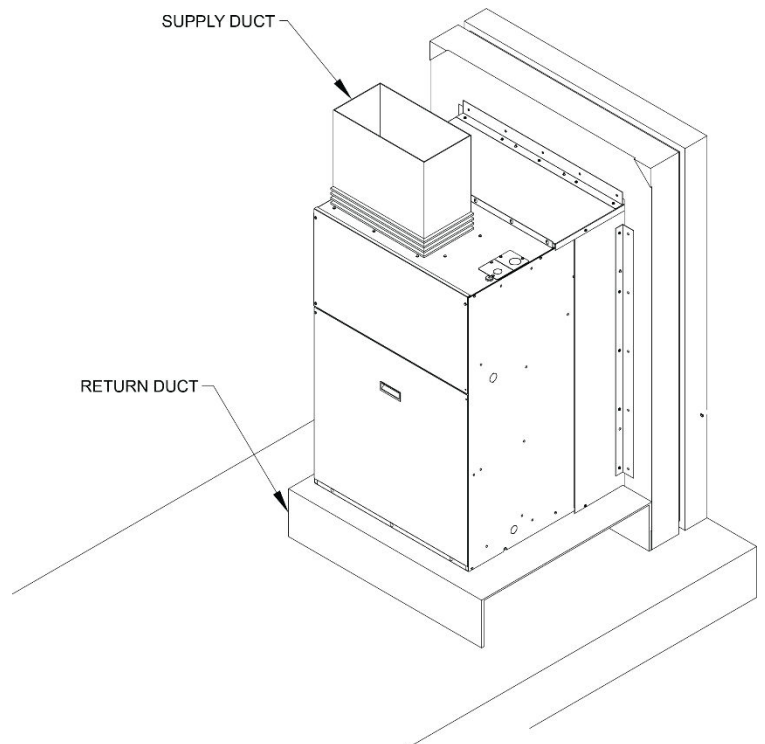
Supply air ductwork should be sized and constructed in accordance with industry best practices and standards.

Insufficiently sized ductwork will cause low supply airflow, which could cause low cooling performance, liquid flood back to compressor and condensate in the cabinet. In heating operation, low airflow could trigger the high-pressure switch protection and stop the compressor. If electric heater is running, low airflow could cause the heater auto-reset limit switch cycle on and off, which would reduce the longevity of heating element. Excessive airflow may result in a noisy duct system and could lower heating supply temps to an uncomfortable level. Unit external static pressure cannot be more than 0.5 in. w.c.

Ductwork should be adequately insulated to prevent condensation and to minimize heat loss within the duct system. A flexible connector is recommended for supply air connections on metal duct systems to limit noise.

**RETURN AIR DUCTING**

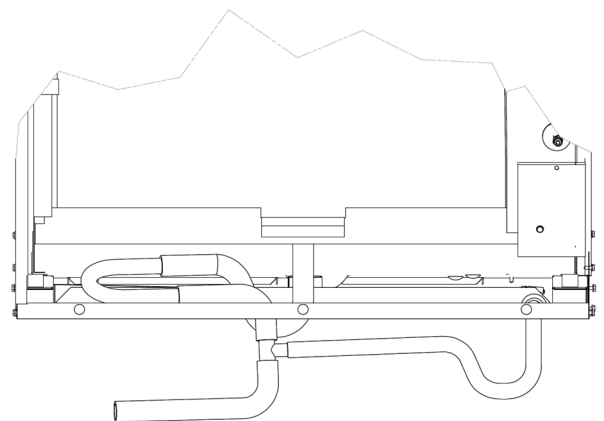
Return air ducting can be brought in through a wall grille or opening and then to the unit. The return duct should be sealed to the return air opening on the bottom of the unit and must terminate inside of the indoor space. It is recommended to use duct material with acoustically lined insulation for sound attenuation. The return duct must be sized for a 24" x 8" [60.96cm x 20.32cm] opening and it is recommended to use sheet metal screws



**FIGURE 14 – Unit Return Ducting**

**CONDENSATE DRAINAGE**

There are two drain pans in the FPH heat pump unit: one under evaporator coil for cooling operation and one under condenser coil for heating operation and rain drain. Drain tube from these two drain pans must be connected to the drain line to discharge condensation. Condensate drain lines must be properly installed with adequate slope away from unit to ensure proper drainage. A minimum trap of 1.5 inches [3.81cm] must be installed to isolate the negative pressures of the drain pan from the drain line. Refer to for schematic information on the condensate drain lines. Drain line should be insulated to prevent condensate dropping to the ground and duct.



**FIGURE 15 –Condensate Drain Layout**

**AIR FILTER**

1. The heat pump unit ships with factory-installed 1” disposable MERV3/4 filter which attaches to the inlet of the evaporator coil.
2. A same size washable filter can be used to replace the existing disposable filter.
3. If a higher efficiency filter which has higher external static pressure is used, the added air pressure drop must be included in the external static pressure. The total external static pressure including duct work should not be more than 0.5 in. w.g. Airflow table should be checked to see if airflow still meets the application requirement and adjusts speed tap if needed.
4. If air filter provided with unit needs to be replaced rotate three (3) filter brackets.

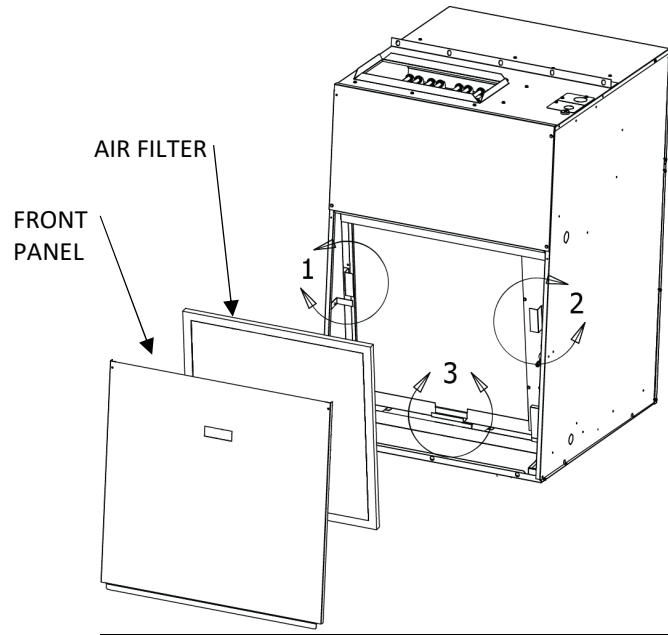


FIGURE 16 –Air Filter Location

**FILTER EXTERNAL STATIC PRESSURE**

FACTORY FILTER SIZE (IN.) AND PRESSURE DROP (IN. W.C.)

Model	Filter Size	Supply Airflow (CFM)								
		200	300	400	500	600	700	800	900	1000
FPH**E1012C	24x24x1	0.003	0.01	0.02	0.03	0.04	---	---	---	---
FPH**E1018C	24x24x1	---	0.01	0.02	0.03	0.04	0.05	0.06	---	---
FPH**E1024C	24x24x1	---	---	0.02	0.03	0.04	0.05	0.06	0.07	---
FPH**E1030C	24x24x1	---	---	---	0.03	0.04	0.05	0.06	0.07	0.07

PERFORMANCE BASED ON FACTORY-PROVIDED MERV3/4 DISPOSABLE FILTER INSTALLED IN THE UNIT. IF A HIGHER RESISTANCE FILTER IS INSTALLED IN THE UNIT, THE ADDED RESISTANCE MUST BE INCLUDED IN THE EXTERNAL STATIC PRESSURE AND MUST NOT EXCEED 0.5 IN. W.C. INCLUDING DUCTWORK.

**FIELD WIRING**

**HIGH VOLTAGE**

! **WARNING** !

⚡ **ELECTRIC SHOCK HAZARD** ⚡

Disconnect all power supplies before servicing. Lock out/tag out to prevent accidental electrical shock.

All wiring and components must be installed by licensed electrical technician and must comply with local and national code requirements. Units are provided with wiring diagrams and nameplate data to provide information required for necessary field wiring.

These units are provided with a class 2 transformer for 24V control circuits.

! **WARNING** !

Use copper conductors only. Install all parts and panels before operation of unit. Failure to follow these warnings can result in injury or death.

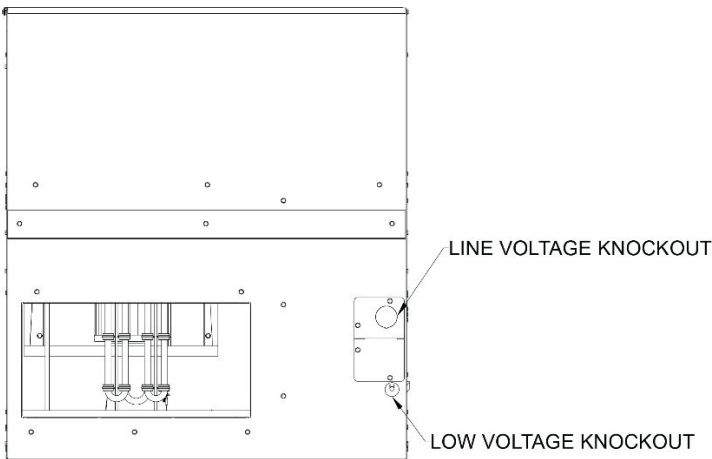
! **WARNING** !

Connect ground wire to green ground screws. Failure to do so can result in injury or death.

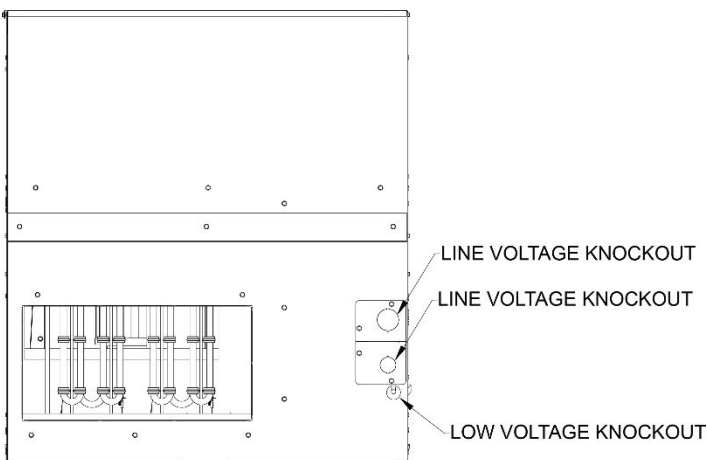
**CAUTION**

Any device that has been furnished by the factory for field installation must be wired in strict accordance with the associated wiring diagram. Failure to do so could damage components and void warranties.

Unit with 3kW or 5kW or 7kW (12K heat pump only) electric heaters has only one power input and has a knockout hole on the top panel for field line voltage connection. Unit with 7kW heater (except 12K heat pump) or 10kW heater has two power inputs and has two knockout holes for field line voltage connection. Refer to **FIGURE 17**, **FIGURE 18**. The ground wire must be connected to the green ground screws in the electric heat housing with gold disk.



**FIGURE 17 – Cabinet with Single Power Input**



**FIGURE 18 – Cabinet with Two Power Inputs**

**208/230 VOLT OPERATION**

All 208/230 Volt units are factory wired for 230 Volt operation. For 208 Volt operation, moving/changing/rewiring the line voltage tap on the 24 Volt control transformer is required. Refer to figures 20-23, note 5 on the wiring diagram for instruction.

**LOW VOLTAGE THERMOSTAT**

A standard 24 VAC thermostat is required to control this unit. A thermostat with a “C” common terminal is preferred. Thermostat must be capable to operate single stage cooling, single stage heat pump and single stage electric heat. Thermostat should be connected to the control wire through the LOW VOLTAGE hole on the top panel shown in **FIGURE 17** and **FIGURE 18**. Thermostat connections and their functions are below in **Table 6 – Thermostat Connections Key** as follows:

THERMOSTAT CONNECTIONS KEY		
Abbr.	Color	Function
C	Brown	24VAC System Common
R	Red	Continuous 24VAC System Power
W	White	Output for Auxiliary Heat Contactor
G	Green	Evaporator Blower, Ventilation
Y	Yellow	Thermostat Call for Compressor
O	Orange	Thermostat Cooling Mode, Energize Reversing Valve

Table 6 - Thermostat Connections Key

**THERMOSTAT INSTALLATION**

The Thermostat should be located on an interior wall in a larger room, away from supply duct draft. Position the thermostat back plate against the wall so that it appears level and so the thermostat wires protrude through the middle of the back plate mounting holes and drill holes with a 3/16” [5mm] bit. Install supplied anchors and secure plate to the wall. Thermostat wire must be 18 AWG wire.

# WIRING DIAGRAMS

## FPH03E1012C, FPH05E1012C ROTARY 208/230V ECM

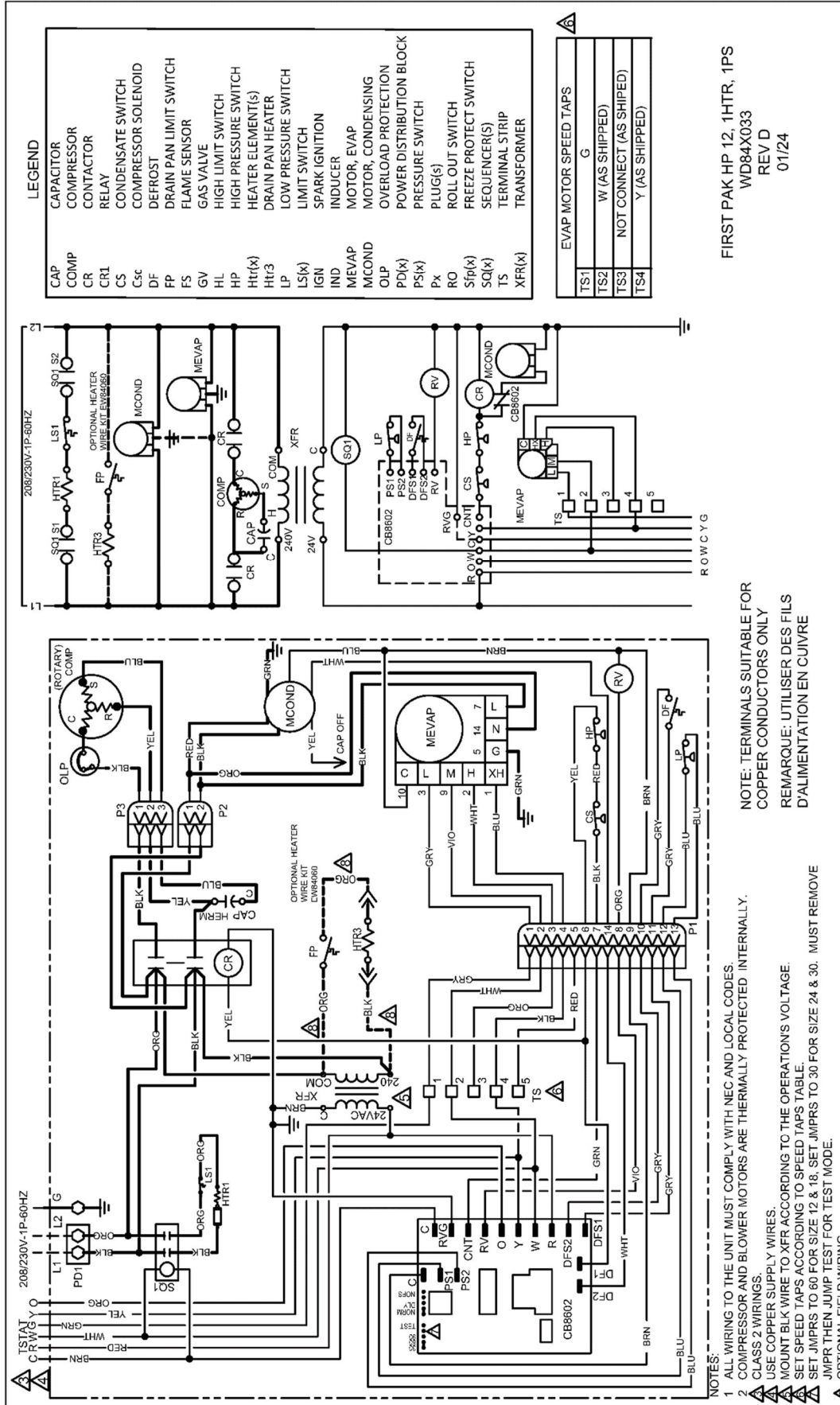


FIGURE 19— FPH03E1012C FPH05E1012C 208/230V ECM Wiring Diagram

WIRING DIAGRAMS

FPH07E1012C ROTARY 208/230V ECM

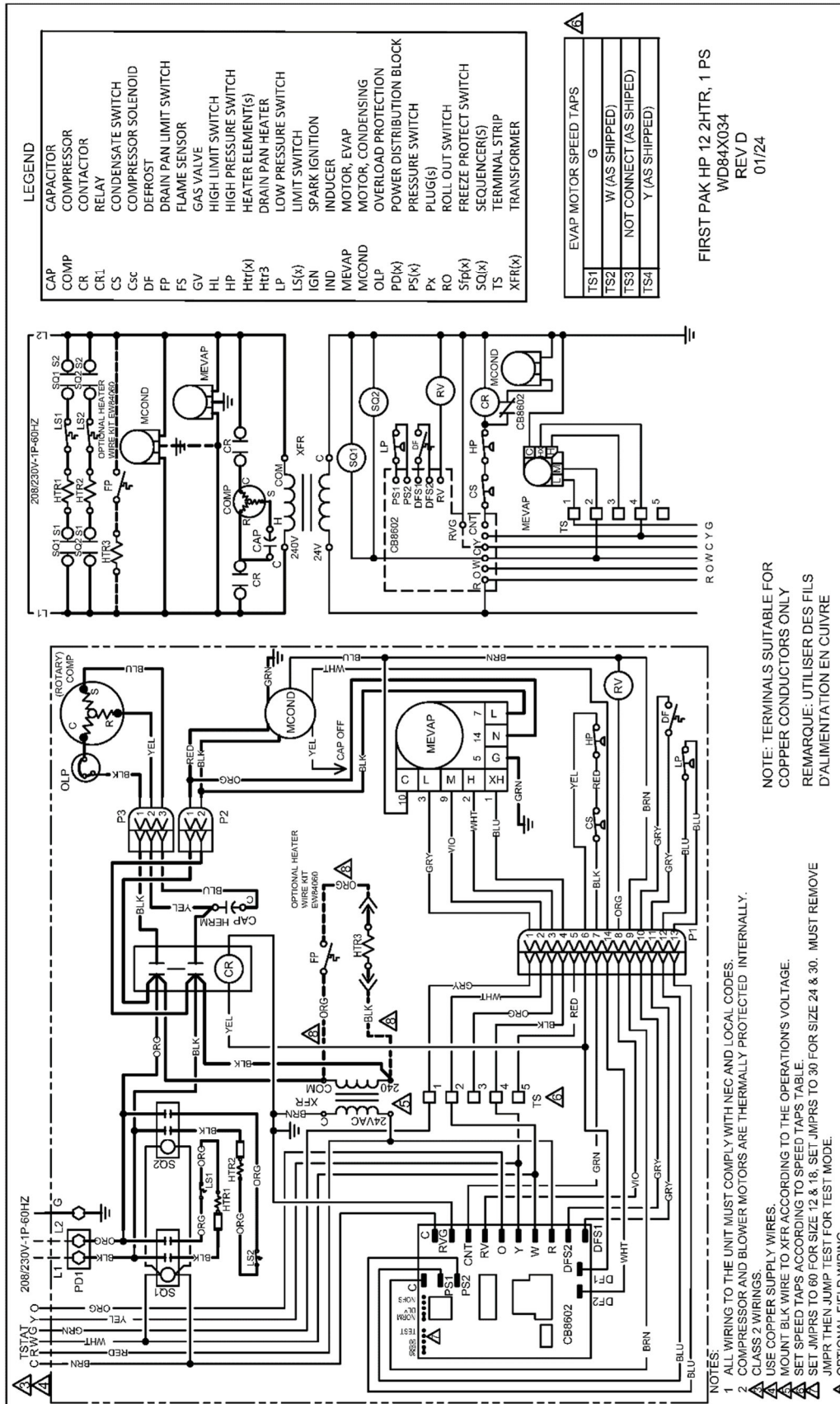


FIGURE 20 – FPH07E1012C ROTARY 208/230V ECM Wiring Diagram

# WIRING DIAGRAMS

## FPH05E1018C, FPH05E1024C, FPH05E1030C SCROLL 208/230V ECM

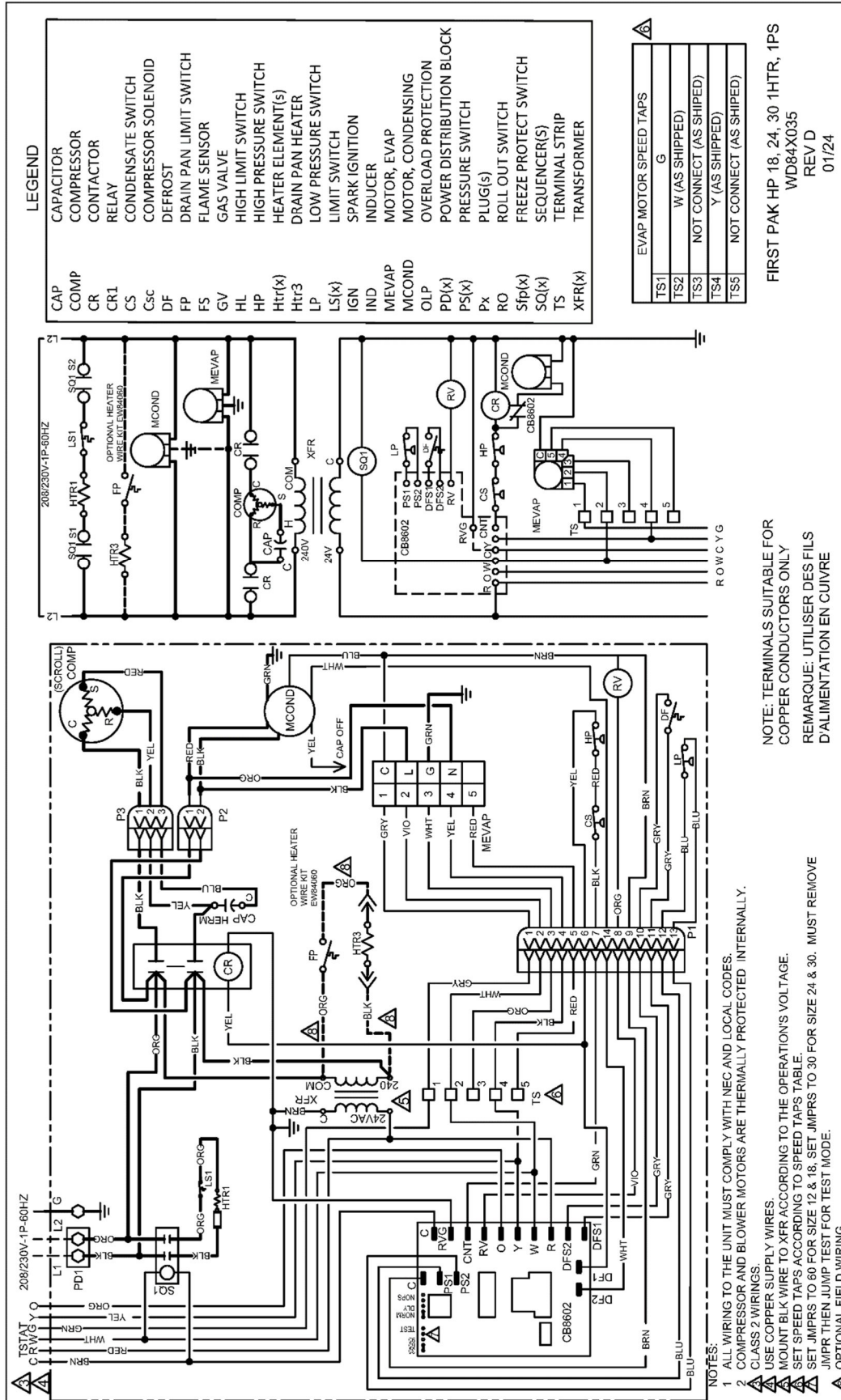


FIGURE 21 – FPH05E1018C, FPH05E1024C, FPH05E1030C SCROLL 208/230V ECM Wiring Diagram



WIRING DIAGRAMS

FPH07E1018C, FPH10E1018C, FPH07E1024C, FPH10E1024C, FPH07E1030C, FPH10E1030C 208/230V ECM

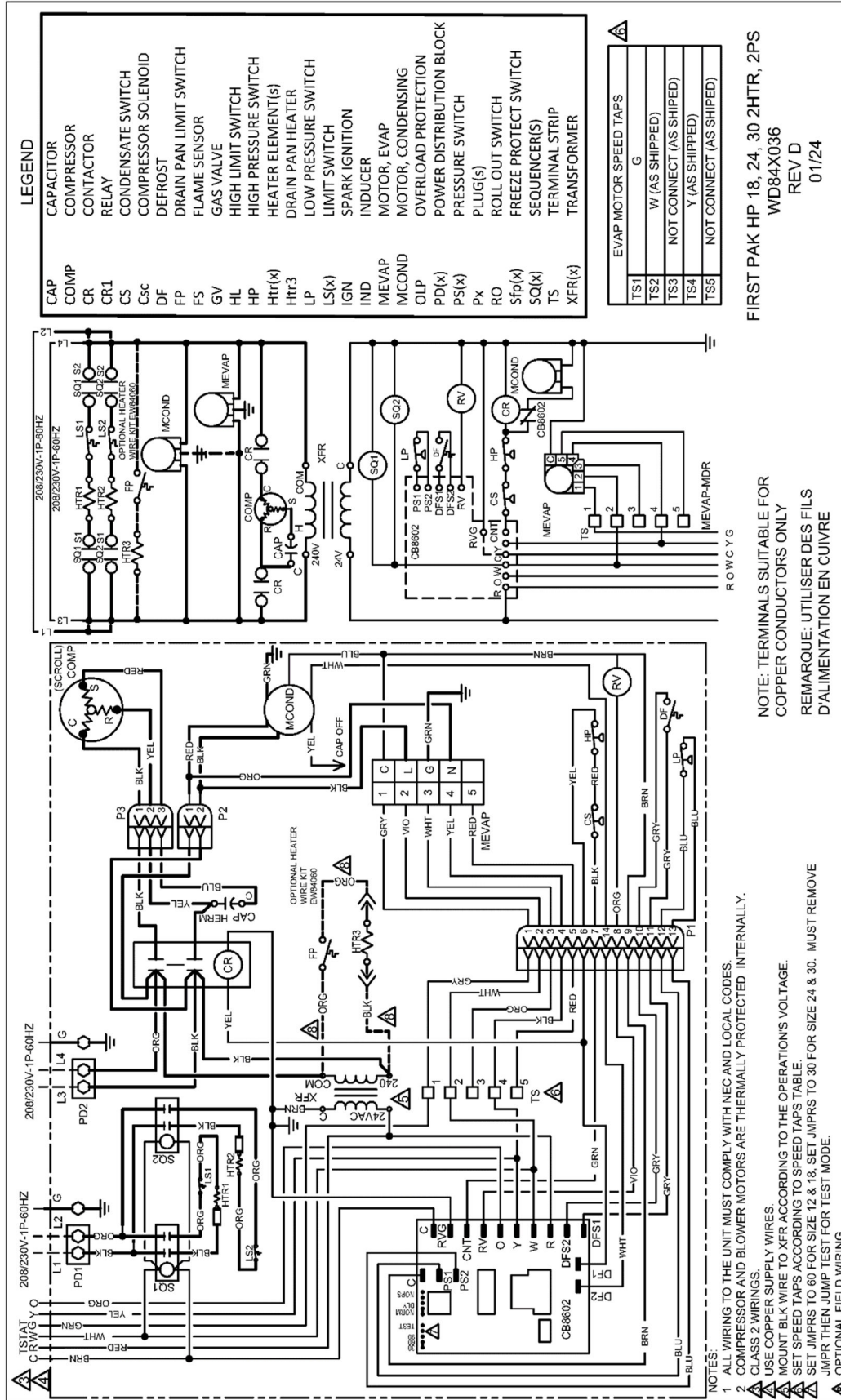


FIGURE 22— FPH07E1018C, FPH10E1018C, FPH07E1024C, FPH10E1024C, FPH07E1030C, FPH10E1030C 208/230V ECM Wiring Diagram

## STARTUP INSTRUCTIONS

### PRE-STARTUP CHECKS:

**WARNING**

Electrically ground the unit. Connect ground wire to ground screw. Failure to do so can result in injury or death.

**CAUTION**

Wire any field installed device such as a fan switch or thermostat furnished by the factory in strict accordance with the wiring diagram supplied with the unit. Failure to do so could result in damage to components and will void all warranties.

After the installation of the unit, first check all the following items before initial start-up.

### PRIOR TO THE STARTUP OF THE UNIT:

1. Ensure supply voltage matches nameplate data.
2. Ensure the power cable is connected to the unit and the ground cable is connected to the green ground screws.
3. Ensure control wire is connected to the thermostat and the wiring matches the wiring diagram.
4. Ensure unit will be accessible for servicing.
5. Ensure condensate line is properly sized, run, trapped, pitched and tested.
6. Ensure all cabinet openings and wiring connections have been sealed.
7. Ensure clean undamaged air filter are in place.
8. Ensure all access panels are in place and secured.
9. Make sure that all electrical connections are tight and secure.
10. they need to check the disconnect for MOP and MCA for wiring size for 208 voltage power, make sure the line voltage tap on the 24 Volt control transformer has been moved and rewired.
11. Make sure the supply duct and return duct have been installed properly and sealed well.
12. Ensure models with 7kw (except 12K heat pump) or 10kW electric heater should have two separate power supplies connected to the unit. Refer to **Table 3**.

### UNIT STARTUP:

1. Ensure that power is connected to the unit and the local disconnect is switched to ON position.
2. Turn on the power.
3. Check that there is 24V output from the control transformer.

## STARTUP & PERFORMANCE CHECKLIST INSTRUCTIONS

Follow the Startup and Performance Checklist to check if the temperature and refrigerant pressure are normal, and if compressor and fans are running properly without abnormal sound. The warranty may be void unless the checklist is completed and returned to the warrantor. If the unit is not installed properly, the warranty will be void as the manufacturer can't be held accountable for problems that stem from improper installation.

# UNIT OPERATIONS

## COOLING MODE

When a call for cooling is made (“Y” and “O” input is energized), the reversing valve energizes. The compressor will energize after 3 minute short cycle period. Unit will operate in cooling mode. The low pressure switch will be bypassed for the first 3 minutes after compressor is energized.

## VENTILATION

When a call for fan only is made “G” input, without additional calls, the unit will operate in continuous fan operation mode. The indoor fan is energized after a .25 second delay. The indoor fan remains energized as long as the “G” input is provided to the unit.

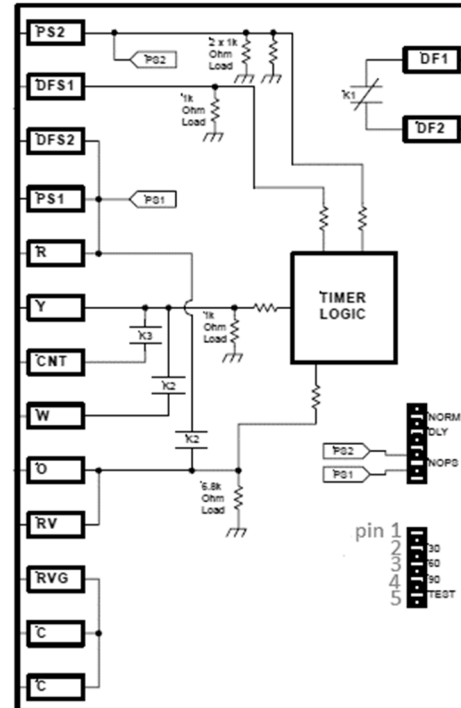
## HEATING MODE

When a call for heat is made (“Y” input is energized), the blower starts operation immediately. The compressor will energize when the 3 minute short cycle period has been satisfied. The electric heat will not energize unless a “W” input is given and will energize after 1-10 second delay to 10 seconds delay. The low pressure switch input will be ignored for the first 3 minutes after compressor is energized.

## DEFROST OPERATION

The FIRST-PAK heat pump unit includes a time-temperature defrost board which has a movable shunt jumper for three selectable defrost interval times (30, 60, 90 minutes) and test mode for field test operation. The factory default setting is 30 minutes. The defrost cycle is controlled by the defrost sensor and accumulated compressor run time.

When the unit is in heating operation, if the defrost switch is closed and the accumulated compressor run time reaches the selected defrost interval time, the control will activate the defrost operation. During defrost the condenser fan stops running, the reversing valve is energized and electric heat is turned on. When defrost switch opens or the maximum defrost time of 10 minutes is reached, the control immediately de-energizes the electric heat and the reversing valve and energizes the condenser fan. The defrost interval timer is reset and unit goes back to normal heating operation.



## DEFROST INTERVAL TIMES

- Pins 1-2: 30 minutes
- Pins 2-3: 60 minutes
- Pins 3-4: 90 minutes
- Pins 4-5: Test Mode

## FIELD TEST OPERATION

The 30-60 shunt jumper in the defrost board must be removed and put on the “TEST” pins for more than 1 second; then the unit will run in the test mode. The test mode operates the same as normal operations at 120 times the normal speed.

To exit test mode, the jumper must be removed from the “TEST” pins, and re-install to 30-60 position; or the jumper remains on the pins for more than 5 minutes.

## WARNING

Failure to remove the 30-60 shunt jumper while “TEST” pin is jumped will result in board failure. Warranty will be void.

## LOW PRESSURE SWITCH

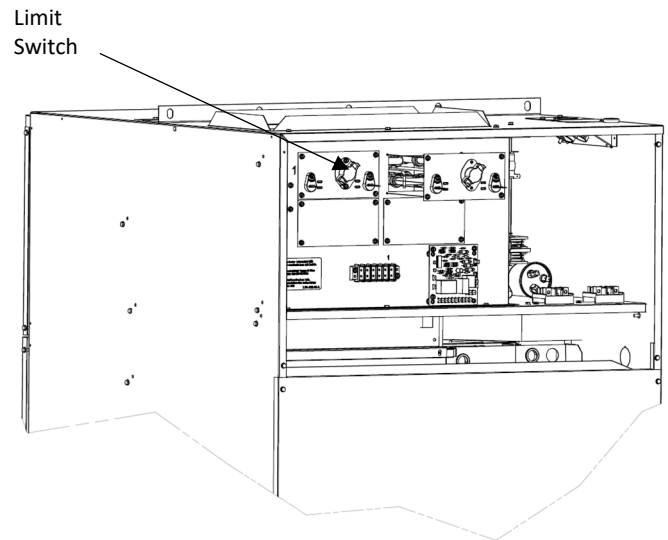
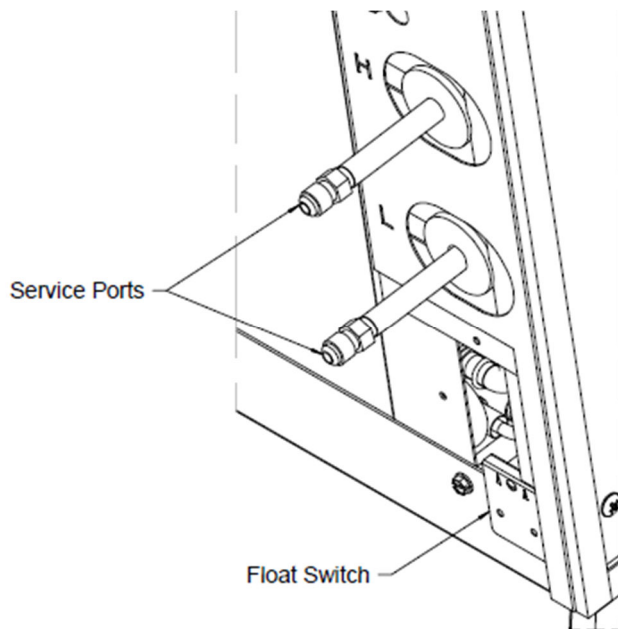
The unit is installed with low pressure switch to provide protection for loss of refrigerant charge by shutting off unit if suction pressure falls below set point.

## HIGH PRESSURE SWITCH

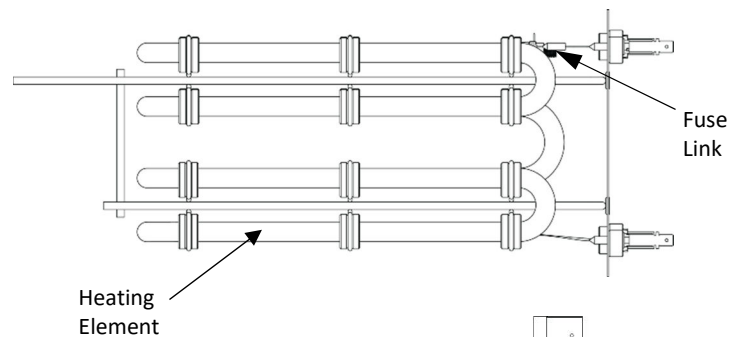
High pressure switch would shut off compressor to protect the refrigeration system from operating under extreme high discharge pressure caused by abnormal operating conditions or failure of condenser fan, dirty coil or TXV malfunction etc.

### OVERFLOW PROTECTION

Condensate overflow located in the bottom of the evaporator drain pan shuts off the compressor if it senses the condensate in the drain pan rises above maximum level.

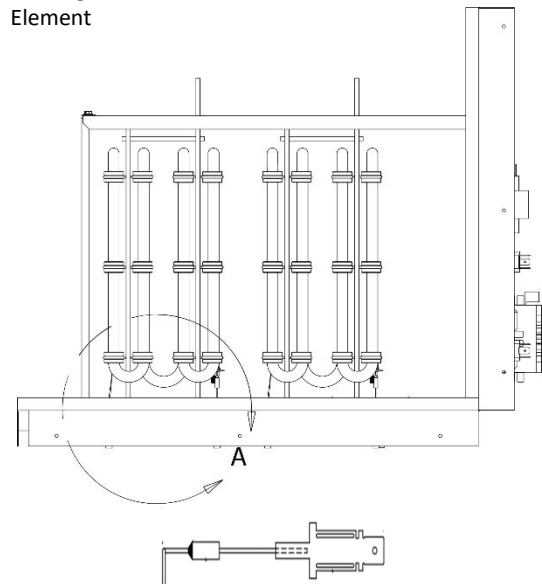


**FIGURE 23 – Auto-Reset Temperature Limit Switch**



### HEATER OVERHEAT PROTECTION

The electric heater is equipped with auto-reset temperature limit switch (**FIGURE 23**) and non-resettable fuse link (**FIGURE 24**). If an abnormal situation such as low airflow due to dirty/clogged air filter, air leak or no airflow due to failed motor, causes the supply air temperature to rise above acceptable limit, the auto-reset limit switch will interrupt the power to the heating elements. Once the heating elements cool down, the limit switch will close and the power to the heating elements will be restored. The heater will resume operation. If the auto-reset limit switch fails to react and is permanently closed, the non-resettable fuse link will activate to cut off the power to the heating elements permanently. The heater will stop working until the fuse link is replaced by a certified technician or agency. See MAINTENANCE & SERVICE- ELECTRIC HEAT section for replacement procedure



**FIGURE 24 – Non-Resettable Fuse Link**

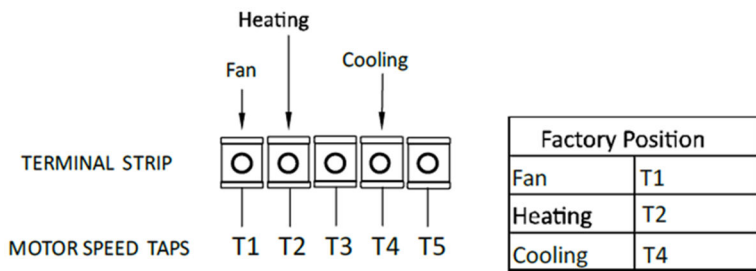
**BLOWER CONTROL**

The FPH heat pump indoor blower fan has an ECM, direct drive, constant torque motor with multiple speed taps that can be changed in the field to meet the actual airflow and the external static pressure. Refer to **FIGURES 19 to 22 WIRING DIAGRAMS** and **TABLES 7 & 8 BLOWER PERFORMANCE DATA**

Unit performance is rated at 0.3” static. For applications with higher external static such as long return or supply duct, blower speed taps should be changed to make sure unit will run properly and efficiently. In order to change the fan speed setting, move the fan speed selection wire to the desired tap. To do this, for model 18K, 24K and 30K, move the white wire connecting to pin 2 in the terminal strip (TS) to pin 3 and move the yellow wire from pin 4 to pin 5. For 12K, only move black wire from pin 2 to pin 3.

! WARNING !

The unit is designed to operate at a maximum of 0.5 in. w.c. external static pressure (ESP). Operating the unit at more than 0.5 in. w.c. ESP may cause unit not working properly and even damage the unit. For applications requiring higher static operation, please contact factory or First Co. sales representative.



**FIGURE 25 – Speed tap for blower control**

BLOWER PERFORMANCE											
Unit Model	Blower Speed Tap	SCFM @ External Static Pressure (in.w.c)									
		0.1		0.2		0.3		0.4		0.5	
		WATT	SCFM	WATT	SCFM	WATT	SCFM	WATT	SCFM	WATT	SCFM
FPH03E1012C	T1	62	595	66	554	69	516	76	489	81	442
	T2 <sup>H</sup>	67	612	71	574	75	537	81	511	86	465
	T3	189	907	197	886	202	860	209	837	214	815
	T4 <sup>C</sup>	157	850	165	828	169	799	177	777	183	754
FPH05E1012C	T1	62	595	66	554	69	516	76	489	81	442
	T2 <sup>H</sup>	107	735	114	706	117	674	125	651	131	620
	T3	174	882	183	861	187	834	195	811	200	789
	T4 <sup>C</sup>	157	850	165	828	169	799	177	777	183	754
FPH07E1012C	T1	64	597	71	571	74	530	81	507	85	459
	T2 <sup>H</sup>	208	934	216	911	222	885	228	862	231	835
	T3	189	906	197	882	203	854	210	832	214	807
	T4 <sup>C</sup>	157	849	165	824	170	793	178	772	184	748
FPH05E1018C	T1	59	539	61	491	64	447	67	409	65	376
	T2 <sup>H</sup>	83	623	89	599	93	564	97	527	103	502
	T3	101	677	109	658	112	626	117	593	126	571
	T4 <sup>C</sup>	133	758	142	740	146	708	152	683	161	661
	T5	155	807	165	785	168	753	176	733	181	709
FPH07E1018C	T1	59	539	61	491	64	447	67	409	65	376
	T2 <sup>H</sup>	83	623	89	599	93	564	97	527	103	502
	T3	101	677	109	658	112	626	117	593	126	571
	T4 <sup>C</sup>	133	758	142	740	146	708	152	683	161	661
	T5	155	807	165	785	168	753	176	733	181	709
FPH10E1018C	T1	59	539	61	491	64	447	67	409	65	376
	T2 <sup>H</sup>	172	841	182	815	185	783	194	764	196	738
	T3	210	902	218	871	221	838	232	818	223	785
	T4 <sup>C</sup>	133	758	142	740	146	708	152	683	161	661
	T5	155	807	165	785	168	753	176	733	181	709

**NOTE:**

- . Airflow data shown is with dry coil at 70°F DB EAT with standard 1" air filter.
- . For 12K heat pump, tap T1 is for ventilation. T2 is for electric heat only operation. T3 and T4 are for cooling and heat pump operation.
- . For 18K heat pump, tap T1 is for ventilation. T2 and T3 are for electric heat. T4 and T5 are for cooling and heat pump operation.
- . Superscript C indicates factory-set default tap for cooling and heat pump. Superscript H indicates factory-set default tap for electric heat.

**Table 7 - BLOWER PERFORMANCE DATA**

\*Data is subject to change. Please verify most current information on [www.firstco.com](http://www.firstco.com) or [www.AE-Air.com](http://www.AE-Air.com) websites.

BLOWER PERFORMANCE											
Unit Model	Blower Speed Tap	SCFM @ External Static Pressure (in.w.c.)									
		0.1		0.2		0.3		0.4		0.5	
		WATT	SCFM	WATT	SCFM	WATT	SCFM	WATT	SCFM	WATT	SCFM
FPH05E1024C	T1	63	626	69	597	74	557	83	523	91	483
	T2 <sup>H</sup>	66	640	72	611	78	572	87	538	96	499
	T3	105	768	114	744	119	710	131	681	138	646
	T4 <sup>C</sup>	176	919	187	898	189	868	196	840	199	806
	T5	209	974	219	954	219	924	224	894	223	858
FPH07E1024C	T1	62	622	69	595	74	556	83	519	91	482
	T2 <sup>H</sup>	65	636	72	610	78	571	87	535	95	498
	T3	105	768	114	746	120	707	131	679	138	648
	T4 <sup>C</sup>	177	922	187	902	190	863	197	838	199	810
	T5	211	977	220	956	221	917	225	891	224	862
FPH10E1024C	T1	62	622	69	595	74	556	83	519	91	482
	T2 <sup>H</sup>	140	849	149	829	154	790	164	765	169	736
	T3	166	902	176	882	180	843	188	818	191	790
	T4 <sup>C</sup>	177	922	187	902	190	863	197	838	199	810
	T5	211	977	220	956	221	917	225	891	224	862
FPH05E1030C	T1	76	677	83	653	89	614	99	581	107	546
	T2 <sup>H</sup>	119	804	128	783	134	744	145	717	151	687
	T3	156	881	165	861	170	822	178	798	182	769
	T4 <sup>C</sup>	241	1023	249	1001	248	961	249	932	245	902
	T5	310	1116	313	1086	305	1043	297	1001	284	964
FPH07E1030C	T1	76	677	83	653	89	614	99	581	107	546
	T2 <sup>H</sup>	119	804	128	783	134	744	145	717	151	687
	T3	156	881	165	861	170	822	178	798	182	769
	T4 <sup>C</sup>	241	1023	249	1001	248	961	249	932	245	902
	T5	310	1116	313	1086	305	1043	297	1001	284	964
FPH10E1030C	T1	76	677	83	653	89	614	99	581	107	546
	T2 <sup>H</sup>	140	849	149	829	154	790	164	765	169	736
	T3	177	922	187	902	190	863	197	838	199	810
	T4 <sup>C</sup>	241	1023	249	1001	248	961	249	932	245	902
	T5	310	1116	313	1086	305	1043	297	1001	284	964

**NOTE:**

- Airflow data shown is with dry coil at 70°F DB EAT with standard 1" air filter.
- Tap T1 is for ventilation. T2 and T3 are for electric heat only operation. T4 and T5 are for cooling and heat pump operation.
- Superscript C indicates factory-set default tap for cooling and heat pump. Superscript H indicates factory-set default tap for electric heat.

**Table 8 - BLOWER PERFORMANCE DATA -CONTINUED**

\*Data is subject to change. Please verify most current information on [www.firstco.com](http://www.firstco.com) or [www.AE-Air.com](http://www.AE-Air.com) websites.

## MAINTENANCE & SERVICE – ELECTRIC HEAT

To ensure maximum performance and service life of equipment, a formal schedule of regular preventative maintenance must be established and adhered to. Failure to establish and perform a preventative maintenance program can void the manufactures warranty.

The electric heater is protected by auto-reset temperature limit switch and non-resettable fuse link for low airflow or no airflow caused by dirty/clogged air filter or motor failure, refer to **FIGURE 23** and **FIGURE 24**.

### FUSE LINK REPLACEMENT

3 kW and 5 kW heaters have one heating element. 7 kW and 10 kW heaters have two heating elements. Each heating element is connected to one fuse link. Refer to **FIGURE 24**. If heater is overheated and auto limit switch fails to react, the fuse link will permanently open and cut off the power to the electric heater. In this case, the fuse link must be replaced in order for the heater to work again. Following below procedures. Follow below procedures.

- 1) Disconnect power to the unit.
- 2) Remove front top panel from the unit. See **FIGURE 26 – Front Top Panel Removal**.
- 3) Disconnect wires from the heating element whose fuse link is open, remove screws from the mounting plate. Refer to **FIGURE 27– Disconnect Wire**
- 4) Take out the heating module. Refer to **FIGURE 28 – Remove Heating Module**
- 5) Replace the broken fuse link. Refer to **FIGURE 24 – Non-Resettable Fuse Link**
- 6) Remove the blank mounting plates to expose viewports to help locate the hole when reinserting the heating module.
- 7) When reinstalling the heating module, make sure the rod is inserted into the hole on the heater support panel. Reinstall heating module and screws (4).

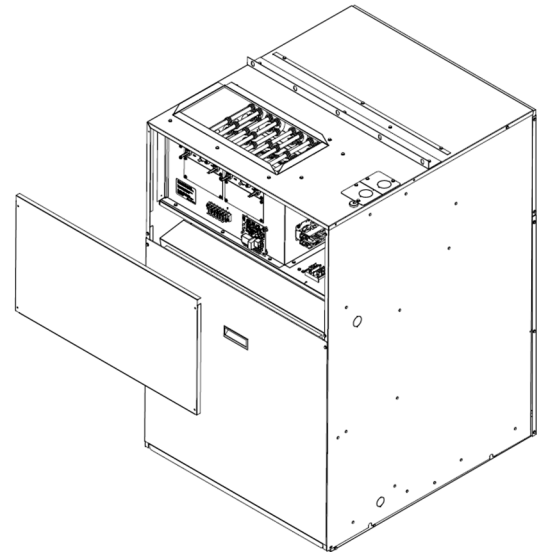
! **WARNING** !

⚡ **ELECTRIC SHOCK, FIRE OR EXPLOSION HAZARD** ⚡

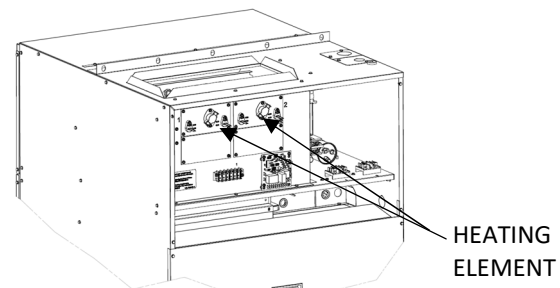
Failure to follow safety warnings operation, serious injury, death or property damage.

Improper servicing could result in dangerous operation death or property damage.

- Before servicing, disconnect all electrical power to the unit.
- When servicing controls, label all wires prior to disconnecting. Reconnect wires correctly.
- Verify proper operation after servicing.



**FIGURE 26 – Front Top Panel Removal**



**FIGURE 27 – Disconnect Wire**



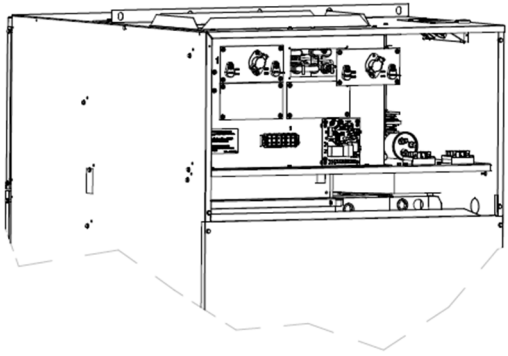


FIGURE 28 – Remove Heating Module

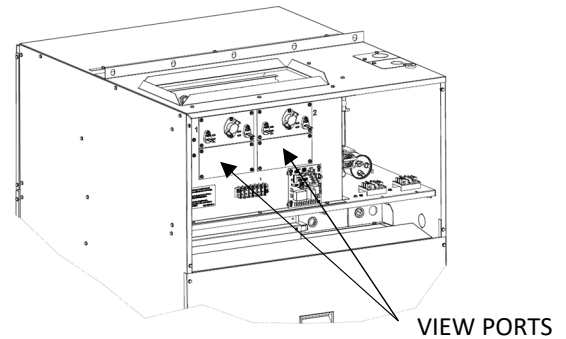


FIGURE 29 – View Ports

## MAINTENANCE & SERVICE – HEAT PUMP SYSTEM

### REFRIGERATION SYSTEM TROUBLESHOOTING

Refrigerant service ports are located in the return air section of the unit. These ports provide easy access to high side (liquid line) and low side (suction line) system pressures for service and maintenance without removing the cooling chassis.

To access these two service ports, remove the air filter access panel.

Liquid line and suction line temperatures may also be measured at the base of the service ports. Sub cooling and superheat may be calculated once these temperatures and pressures are known.

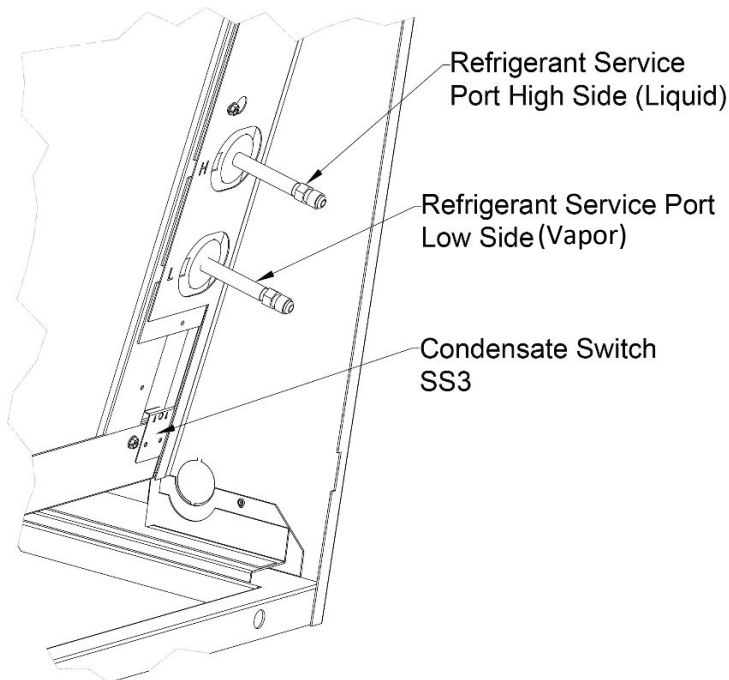


FIGURE 30 – Refrigeration Pressure Ports

### COOLING CHASSIS REMOVAL

To fix a refrigerant leak or replace refrigeration components such as compressor, TXV, filter drier, etc., the whole cooling chassis must be removed. Follow the below procedure to remove the cooling chassis from the cabinet.

- 1) Turn off unit power at the external disconnect.
- 2) Remove screws (4) from front top panel and screws (2) from filter access panel. Remove both panels from unit. Refer to **Figure 31 – Removal of Front Panels**.

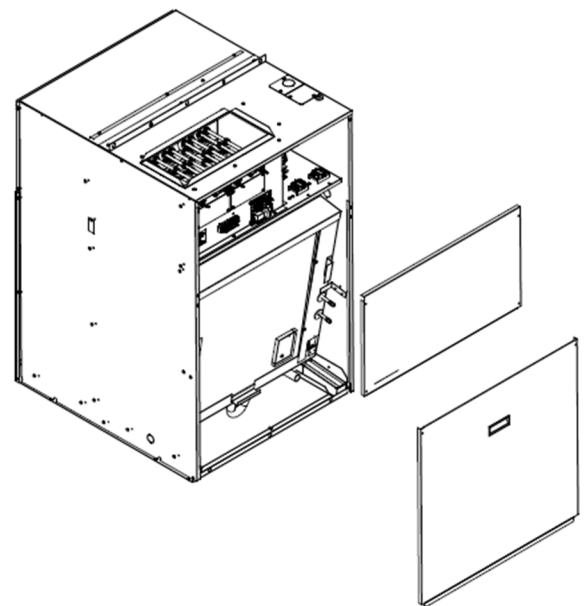


FIGURE 31 – Removal of Front Panels

- 3) Disconnect the low voltage connector and the two (2) high voltage connectors by pressing on the release tabs. Refer to **FIGURE 32- Electrical Power Disconnection**.

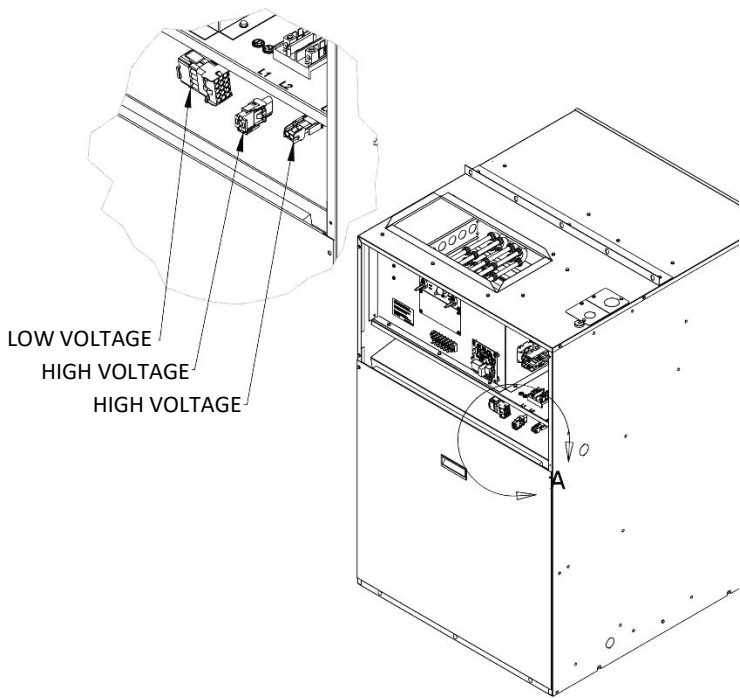


FIGURE 32 – Electrical Power Disconnection

- 4) Slide-out cooling chassis. FIGURE 33–Slide Out Cooling Chassis.

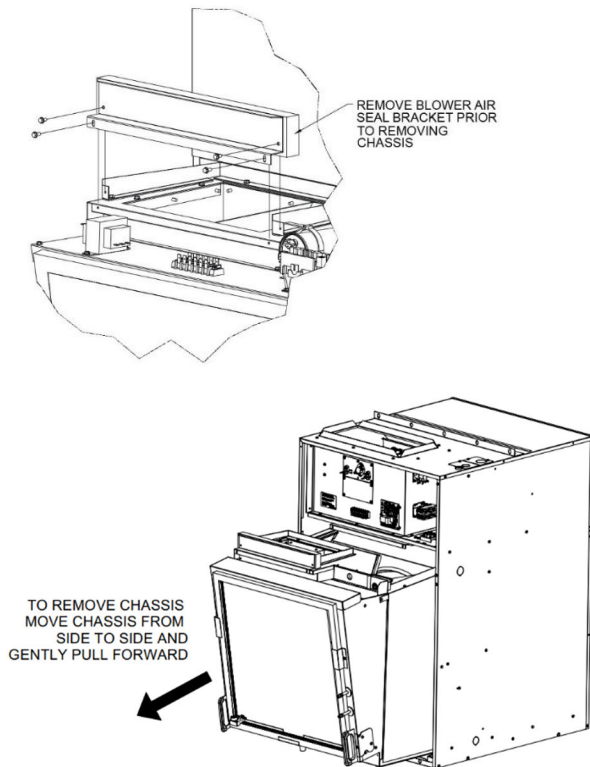


FIGURE 33 – Slide Out Cooling Chassis

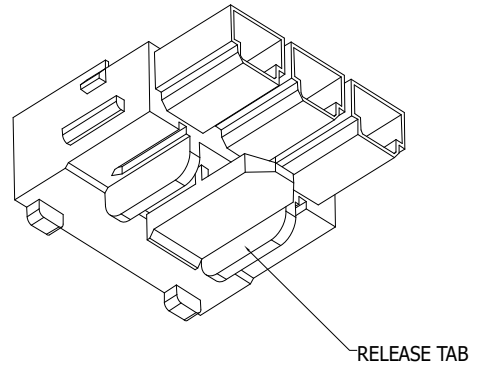


FIGURE 34- Line Voltage Connector

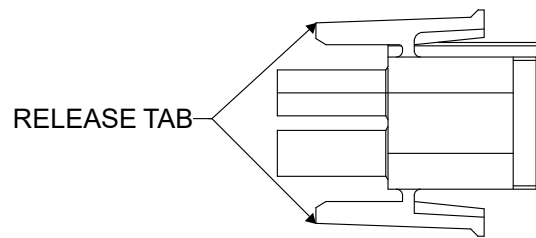
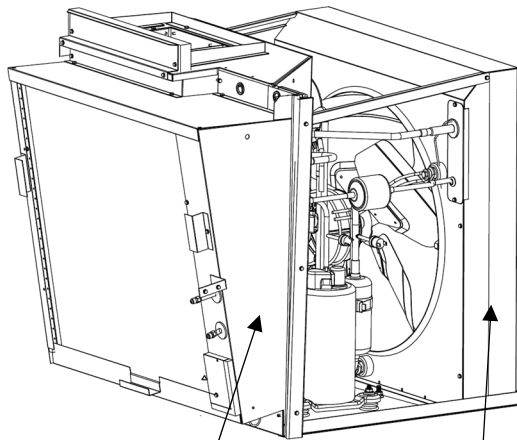


FIGURE 35- High Voltage Connector

<b>!</b>	<b>WARNING</b>	<b>!</b>
<b>⚡</b>	<b>ELECTRIC SHOCK HAZARD</b>	<b>⚡</b>
<p>Check motor connections to ensure they are secure and in accordance with the unit wiring diagram.</p> <p>ECM motors have line voltage power applied at all times.</p> <p><b>MAKE SURE POWER IS DISCONNECTED BEFORE SERVICING.</b></p>		

<b>i</b>	<b>NOTE</b>	<b>i</b>
<p>All refrigeration components can be serviced in the chassis.</p>		

- 5) Evaporator and condenser coil side panels can be removed from the chassis section to access the two TXV's.



Remove this side panel to serve indoor TXV  
Remove this side panel to serve outdoor TXV

FIGURE 36- TXV Location Outside

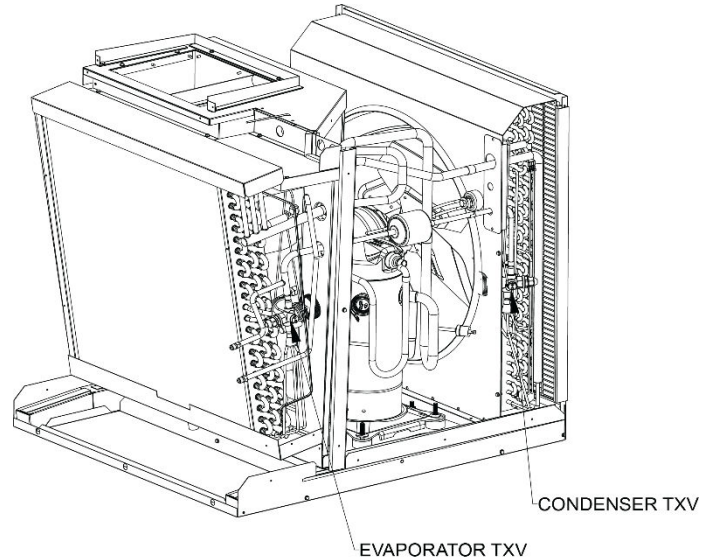


FIGURE 37- TXV Location Inside

**COOLING CHASSIS REASSEMBLY**

- 1) To put-back the chassis, make sure all the refrigerant lines are in place and there are no leaks.
- 2) Slide chassis back into the unit.
- 3) Connect the electrical connections back as they previously were.

**PREVENTIVE MAINTENANCE**

To achieve maximum performance and service life of equipment, a formal schedule of regular maintenance should be established and followed.

! WARNING !

It is illegal to discharge refrigerant into the atmosphere. Use proper reclaiming methods and equipment when installing or servicing this unit. Service should be performed by a QUALIFIED service agency. The refrigerant system contained in the unit normally requires no maintenance since it is a closed, self-contained system.

! CAUTION !

All appropriate personal protection equipment should be worn when servicing or maintaining this unit.

Personal injury can result from sharp metal edges, moving parts, and hot or cold surfaces.

**FAN**

For any other refrigeration servicing, the refrigeration chassis can be removed as explained in the **COOLING MODULE REMOVAL** Section

**FILTER**

The air filter should be cleaned or replaced every 30 days or more frequently if severe operating conditions exist. Always replace the filter with the same type and size as originally furnished. It's recommended to clean filter at least 3 times in summer and winter season or more if needed. The air filter should be inspected every 30 days, replace or clean as needed. MERV rated filters may decrease air flow that could cause issues with the unit performance. Please contact factory for recommendations.

**COIL**

Clean all heat transfer surfaces and remove all dirt, dust, and contaminants that potentially impairs air flow using industry accepted practices. Care should be taken not to bend coil fin material. Care should not be taken to use toxic or caustic cleaning solutions. Steam cleaning is recommended.

**CONDENSATE DRAIN PANS AND PIPES**

Check and clean all dirt and debris from pan. Ensure drain line is free flowing and unobstructed.

**UNIT PERFORMANCE**

Record performance measurements of volts, amps, and air temperature differences. A comparison of logged data with startup and other annual data is an useful indicator of general equipment condition.

**LABORATORY TESTING**

When the unit has less than 100 operational hours and the coils have not had sufficient time to be "seasoned", it is necessary to clean the coils with mild surfactant such as Calgon to remove the oils left by manufacturing processes.

## STARTUP & PERFORMANCE CHECKLIST

CUSTOMER \_\_\_\_\_ STARTUP DATE \_\_\_\_\_ JOB # \_\_\_\_\_  
 ADDRESS \_\_\_\_\_ SERVICING COMPANY \_\_\_\_\_  
 \_\_\_\_\_ TECHNICIAN \_\_\_\_\_  
 MODEL # \_\_\_\_\_ SERIAL # \_\_\_\_\_ PHONE # \_\_\_\_\_

## INSTALLATION CHECK LIST

- Inspect the unit for transit damage and report any damage on the carrier's freight bill.
- Check model number to insure it matches the job requirements.
- Install field accessories and unit adapter panels as required. Follow accessory and unit installation manuals.
- Verify field wiring, including the wiring to any accessories.
- Check all multi-tap transformers, to insure they are set to the proper incoming voltage.
- Prior to energizing the unit, inspect all the electrical connections.
- Power the unit. Bump the motor contractor to check rotation. Three phase motors are synchronized at the factory. If the blower fans are running backwards, de-energize power to the unit, then swap two of the three incoming electrical lines to obtain proper phasing. Re-check.
- Perform all start up procedures outline in the installation manual shipped with the unit.
- Fill in the Start Up Information as outlined below and on the following page.
- Provide owner with information packet. Explain the thermostat and unit operation.

## START UP INFORMATION SHEET

### ELECTRICAL

Supply Voltage L1-L2 \_\_\_\_\_ L3-L4 \_\_\_\_\_ Compressor Amps \_\_\_\_\_  
 Running Voltage L1-L2 \_\_\_\_\_ L3-L4 \_\_\_\_\_ Blower Amps \_\_\_\_\_  
 Secondary Voltage \_\_\_\_\_ Condenser Fan Amps \_\_\_\_\_  
 C (black) to G (green) Volts\* \_\_\_\_\_  
 C (black) to W (white) Volts\* \_\_\_\_\_

\*With thermostat calling.

### TEMPERATURES

Outdoor Air Temperature \_\_\_\_\_ DB \_\_\_\_\_ WB \_\_\_\_\_  
 Return Air Temperature \_\_\_\_\_ DB \_\_\_\_\_ WB \_\_\_\_\_  
 Cooling Supply Air Temperature \_\_\_\_\_ DB \_\_\_\_\_ WB \_\_\_\_\_  
 Heating Supply Air Temperature \_\_\_\_\_ DB \_\_\_\_\_ WB \_\_\_\_\_

### REFRIGERATION

Suction Pressure (Prior to Startup) \_\_\_\_\_ Psig  
 Liquid Pressure (Prior to Startup) \_\_\_\_\_ Psi

**STARTUP & PERFORMANCE CHECKLIST CONTINUED****UNIT OPERATION****HEATING MODE**

- 1 ELECTRIC HEATER AMPS \_\_\_\_\_
- 2 INDOOR BLOWER AMPS \_\_\_\_\_
- 3 TEMPERATURE RISE
- Supply Air Temperature \_\_\_\_\_
- Return Air Temperature - \_\_\_\_\_
- Temperature Rise = \_\_\_\_\_
- 4 TOTAL EXTERNAL STATIC
- Supply External Static \_\_\_\_\_
- Return External Static + \_\_\_\_\_
- Total External Static = \_\_\_\_\_

**COOLING MODE**

- 5 INDOOR BLOWER AMPS \_\_\_\_\_
- 6 TEMPERATURE DROP
- Return Air Temperature \_\_\_\_\_
- Supply Air Temperature - \_\_\_\_\_
- Temperature Drop = \_\_\_\_\_
- 7 TOTAL EXTERNAL STATIC (dry coil)
- Supply External Static \_\_\_\_\_
- Return External Static + \_\_\_\_\_
- Total External Static = \_\_\_\_\_
- 8 DRAIN LINE
- Leak Free
- 9 THERMOSTAT
- Adjusted & Programmed
- Explained Operation to Owner
- 10 REFRIGERATION
- Suction Pressure \_\_\_\_\_ Psig      Liquid Pressure \_\_\_\_\_ Psig
- Suction Temperature \_\_\_\_\_ °F      Liquid Temperature \_\_\_\_\_ °F

The warranty may be void unless the Startup & Performance Checklist is completed and returned to the warrantor. If the HVAC unit is not installed properly the warranty will be void as the manufacturer can't be held accountable for problems that stem from improper installation.

## NOTES

---



P.O. Box 270969 Dallas, TX 75227  
[www.firstco.com](http://www.firstco.com) or [www.ae-air.com](http://www.ae-air.com)

The manufacturer works to continually improve its products. It reserves the right to change design and specifications without notice.

©2023 First Co., Applied Environmental Air