

*First Co.*

# SHWX SERIES

*DIRECT DRIVE*

Horizontal 0-10V DC Input Controlled Unit

Chilled Water

Hot Water

800 Thru 4,000 Nominal CFM

Direct Drive ECM Motor



---

# TABLE OF CONTENTS

NOMENCLATURE .....	3
NOMENCLATURE DRIVE KIT.....	4
SERIES FEATURES .....	5
DIMENSIONS & GENERAL SPECIFICATIONS.....	6-7
OPTIONS .....	8-10
COMPONENT STATIC RESISTANCE .....	11
BLOWER DATA .....	12-17
CW COOLING CAPACITIES & HW HEATING CAPACITIES .....	18-23
SPECIFICATION GUIDE .....	24
HOT WATER HEATING CORRECTION FACTORS .....	25

First Co.'s customer is ultimately responsible for confirming which fan coil models are compatible with selected outdoor unit(s) and which expansion valves (if any) are required. To determine certified indoor/outdoor combinations, go to [www.firstco.com](http://www.firstco.com) or contact the factory.

In keeping with its policy of continuous progress and product improvement, First Co. reserves the right to make changes without notice.

# NOMENCLATURE

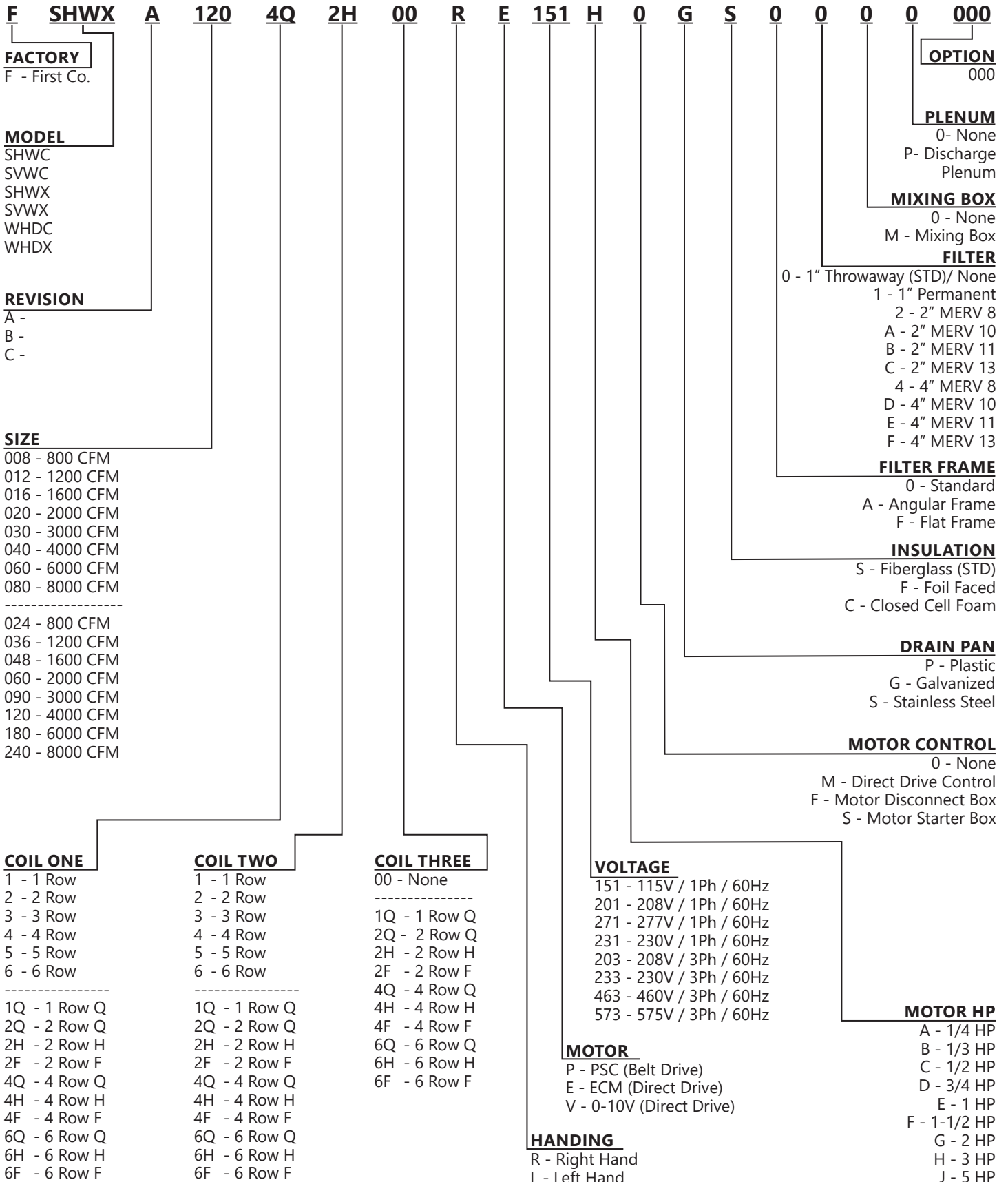

# NOMENCLATURE

## DRIVE KIT NOMENCLATURE

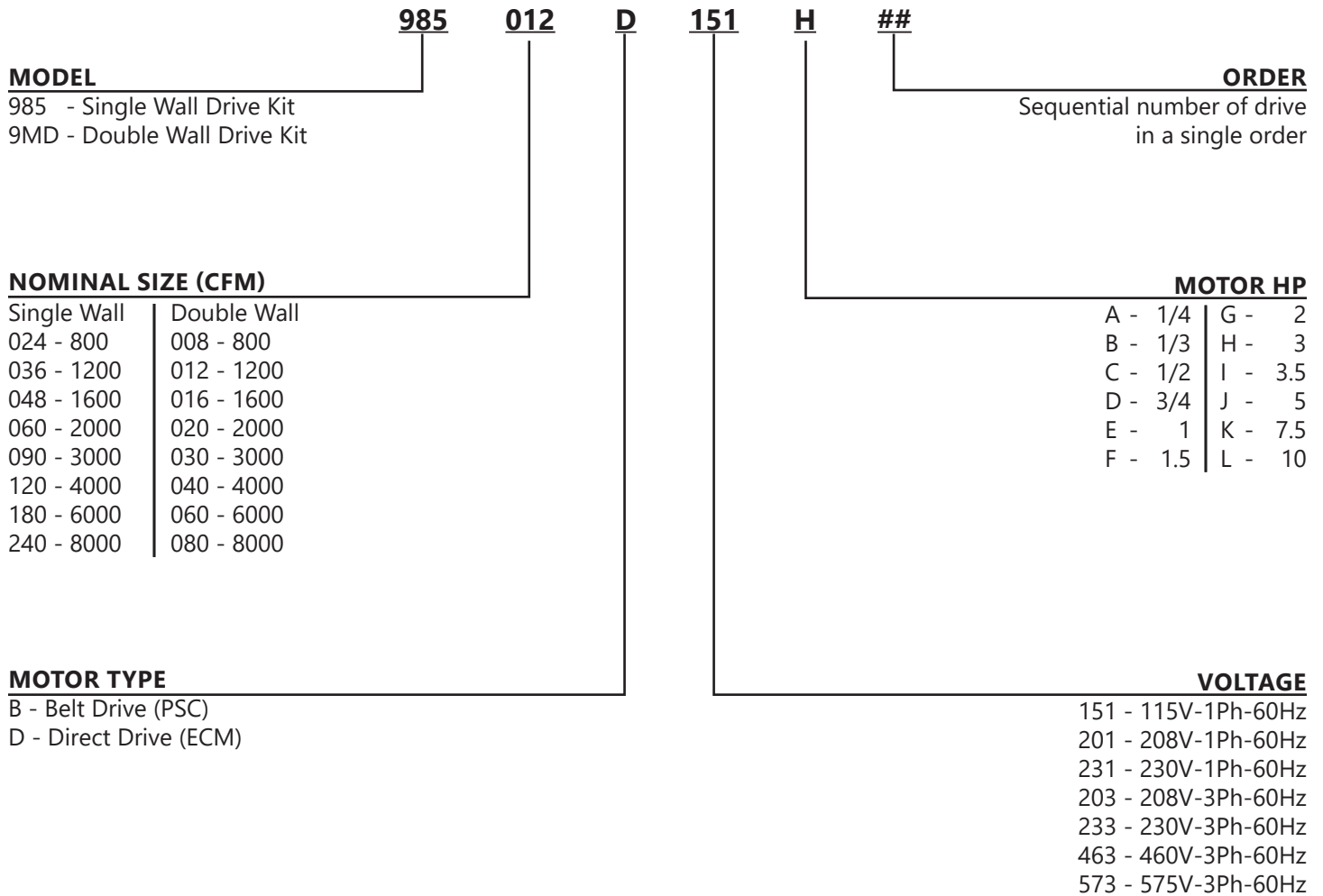

## REQUIRED ORDER INFORMATION

1. Model number with rows and circuit
2. CFM and external static pressure
3. Motor HP
4. Actual voltage motor is to be wired to
5. Hot water coil installed in preheat or reheat position
6. Hand connections with air hitting you in back of head

---

# SHWX SERIES

## DIRECT DRIVE HORIZONTAL 0-10V DC INPUT CONTROLLED UNIT

### FEATURES

**The SHWX Direct Drive – Horizontal Unit** is a completely factory assembled, single-piece air handler.

The unit includes a fan and coil section with factory installed chilled water, preheat or reheat hot water coil position, and a 2" filter section. Field mounted components include a mixing box or discharge plenum.



SHWX

### STANDARD FEATURES

#### CABINET

Fabricated of heavy gauge galvanized steel. Seismic resistant mounting brackets are standard on 2-5 ton models.

#### BLOWER

Resiliently mounted, heavy duty, double inlet, forward curved blade, centrifugal type. Direct Drive ECM 0-10V DC controls and wheel is dynamically balanced for smooth, quiet operation.

#### COILS

Fabricated of 3/8" or 1/2" OD seamless copper tubes mechanically expanded to highly efficient aluminum fins to maximize heat transfer. All coils have manual air vents. All models have positive slope drain pans.

#### INSULATION

The entire interior of the cabinet is insulated with one (1") inch insulation.

#### FILTER

One inch throw away filters are provided as standard in all 2 - 5 ton units. One inch filter is provided and permanent filters are provided as standard in all 7-1/2 - 10 ton units. Optional permanent, Merv 11 and Merv 13 Filters also available in 1". Filters can be changed without tools. Space available for 2".

#### FACTORY WIRED

All standard motors are field or factory installed and wired at voltage specified by customer. (If not specified, multi-voltage motors will be wired at highest voltage)

#### MOTOR

Standard motor for 2 through 5 ton have constant air flow ECM motor. The 7.5 through 10 ton have a constant torque motor. Standard motors have internal overload protection. All Motors are UL certified.

#### MISCELLANEOUS

- Slotted mounting rails for easy installation (2 -5 ton SHWX only). Rails are turned down 1/2" on each end for safer and easier installation.
- 3/4 inch NPT drain connections.
- All units come with factory mounted control box.
- Header connections on the right side as standard. Knockouts are provided for conversion to the left side. (Looking with air flow).
- Drain pans are coated for corrosion protection.

# SHWX SERIES

DIRECT DRIVE HORIZONTAL 0-10V DC INPUT CONTROLLED UNIT

## DIMENSIONS

MODELS 24SHWX – 60SHWX

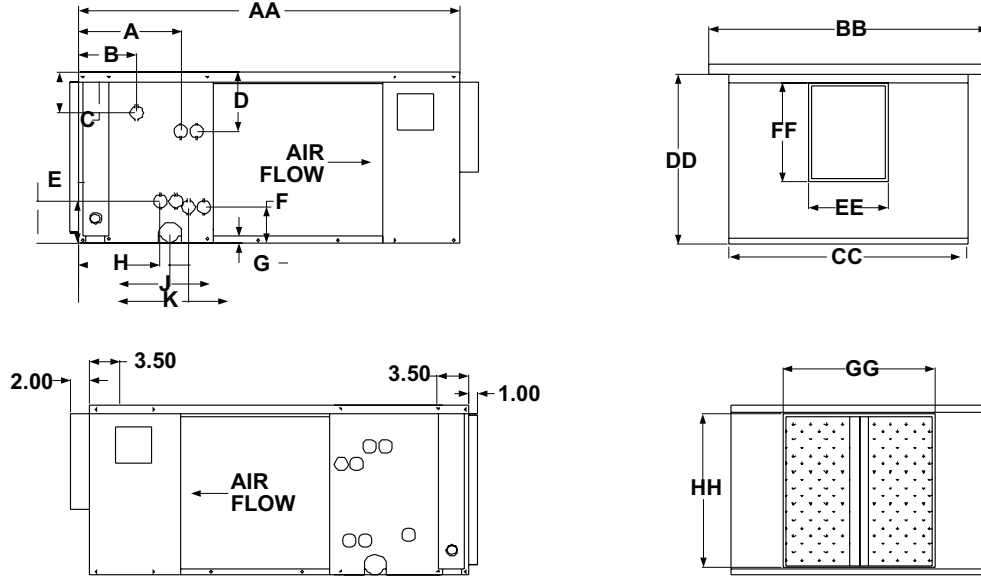

SHWX – UNIT DIMENSIONS

MODEL	UNIT CABINET				BLOWER OUTLET		RETURN DUCT CONNECTION		STUBOUT LOCATION FOR WATER COILS									
	AA	BB	CC	DD	EE	FF	GG	HH	A	B	C	D	E	F	G	H	J	K
24SHWX4	37	32-1/2	27	18-7/8	8-3/4	10-7/8	18	16-1/4	11-1/4	6-5/16	4-1/2	6-1/2	4-1/2	3-15/16	1	8-15/16	10	12
36SHWX4	37	42	36-1/2	18-7/8	10-3/4	10-7/8	27-1/2	16-1/4	11-1/4	6-5/16	4-1/2	6-1/2	4-1/2	3-15/16	1	8-15/16	10	12
48SHWX4	39	43-1/2	38	22-7/8	12-1/4	10-7/8	29	20-1/4	11-1/4	6-5/16	3-3/4	5-3/4	4-1/2	3-15/16	1	8-15/16	10	12
60SHWX4	42	50-1/2	45	22-7/8	10-3/4	11-7/8	36	20-1/4	11-1/4	6-5/16	3-3/4	5-3/4	4-1/2	3-15/16	1	8-15/16	10	12

- NOTES:**
1. All drain connections are 3/4" MPT and located on same side as coil connections.
  2. All units have knockouts on both sides for either (standard) or left side coil stub outs. (Viewing with airflow)  
All coil connections must be on the same side of the unit.

SHWX – GENERAL SPECIFICATIONS

MODEL	NOM. COOL TONS	FACE AREA SQ. FT.	TUBE SIZE	STD. MOTOR HP	VOLTS	PHASE	BLOWER SIZE	FILTER SIZE	4 ROW COIL		6 ROW COIL	
									MANIFOLD CONNECTION	SHIPPING WEIGHT	MANIFOLD CONNECTION	SHIPPING WEIGHT
24SHWX	2	2.05	3/8	1/3	115/230/277	1	9 X 6	16 X 25	7/8" O/D (SWT)	185	7/8" O/D (SWT)	205
36SHWX	3	3.05	3/8	1/2	115/230/277	1	9 X 8	16 X 16 (2)	7/8" O/D (SWT)	205	7/8" O/D (SWT)	225
48SHWX	4	4.0	3/8	3/4	115/230/277	1	9 X 9	16 X 20 (2)	7/8" O/D (SWT)	230	7/8" O/D (SWT)	265
60SHWX	5	5.0	3/8	1	115/230/277	1	10 X 8	20 X 20 (2)	1-1/8" O/D (SWT)	290	1-1/8" O/D (SWT)	310

- NOTES:**
1. All technical specifications subject to change without notice.
  2. Additional charge for optional motors.
  3. When SHWX units are used with hot water coil the leaving air temperature must not exceed 150°F.  
At high altitude conditions, blower motor may cutout air lower LAT. Contact factory for information.
  4. Contact factory for electric heat information (supplied by others)

# SHWX SERIES

DIRECT DRIVE HORIZONTAL 0-10V DC INPUT CONTROLLED UNIT

## DIMENSIONS

MODELS 90SHWX – 120SHWX

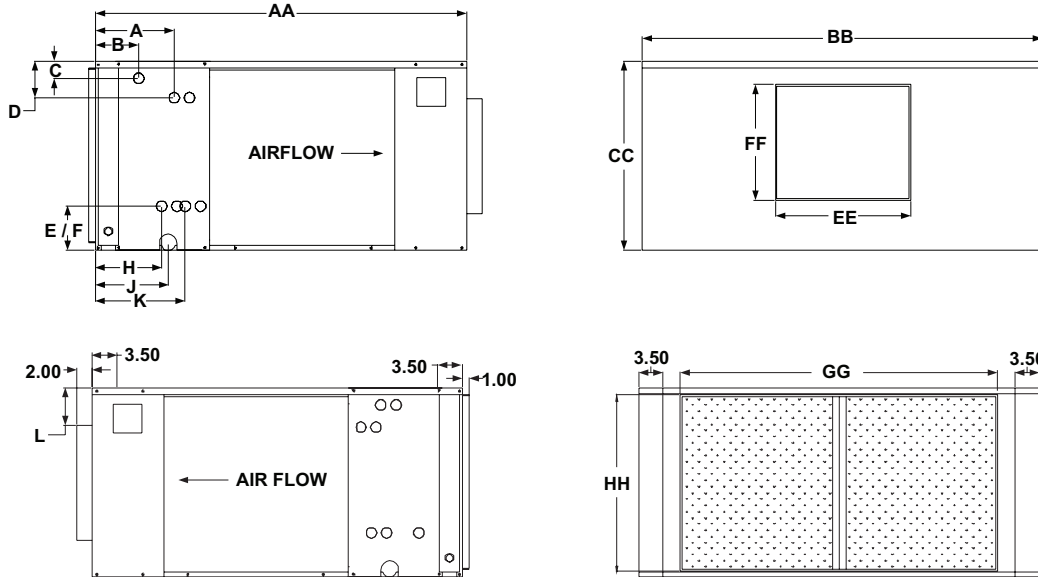

SHWX – UNIT DIMENSIONS																		
MODEL	UNIT CABINET			BLOWER OUTLET		RETURN DUCT CONNECTION		STUBOUT LOCATION FOR WATER COILS										
	AA	BB	CC	EE	FF	GG	HH	A	B	C	D	E	F	G	H	J	K	L
90SHWX4	52-1/2	54	27	16-1/2	16-3/8	45	25-1/4	11-1/8	6-1/8	2-7/16	5-1/8	6-7/16	6-7/16	1	9-3/8	10-1/4	12-5/8	1
120SHWX4	52-1/2	57	32	19-1/8	16-3/8	48	30-1/4	11-1/8	6-1/8	2-7/16	5-1/8	6-7/16	6-7/16	1	9-3/8	10-1/4	12-5/8	6

- NOTES:**
- All drain connections are 3/4" MPT and located on same side as coil connections.
  - All units have knockouts on both sides for either (standard) or left side coil stub outs. (Viewing with airflow)  
All coil connections must be on the same side of the unit.

SHWX – GENERAL SPECIFICATIONS													
MODEL	NOM. COOL TONS	FACE AREA SQ. FT.	TUBE SIZE	STD. MOTOR HP	VOLTS	PHASE	BLOWER SIZE	FILTER SIZE	4 ROW COIL		6 ROW COIL		
									MANIFOLD CONNECTION	SHIPPING WEIGHT	MANIFOLD CONNECTION	SHIPPING WEIGHT	
90SHWX	7-1/2	7.5	1/2	3.5	230/460/575	3	15 X 12	24 X 25 (2)	1-1/8" O/D (SWT)	450	1-1/8" O/D (SWT)	475	
120SHWX	10	9.6	1/2	5	230/460/575	3	15 X 15	26 X 29 (2)	1-3/8" O/D (SWT)	490	1-3/8" O/D (SWT)	535	

- NOTES:**
- All technical specifications subject to change without notice.
  - Additional charge for optional motors.
  - When SHWX units are used with hot water coil the leaving air temperature must not exceed 150°F.  
At high altitude conditions, blower motor may cutout air lower LAT. Contact factory for information.
  - Contact factory for electric heat information (supplied by others).

# SHWX SERIES

## DIRECT DRIVE HORIZONTAL 0-10V DC INPUT CONTROLLED UNIT

### OPTIONS

1. 6 row cooling coil instead of standard 4 row coil (factory installed only).
2. Stainless steel drain pan.
3. Hot water coil can be field or factory installed in either the reheat or pre-heat position (reheat is standard).

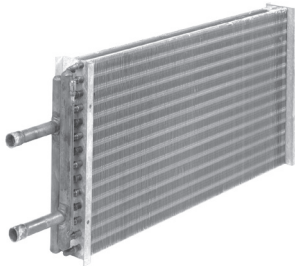
SHWX – AVAILABLE OPTIONS			
PART NUMBER	FOR UNIT MODEL	MANIFOLD CONNECTIONS	RENDER
24HWK	24SHWX	7/8" OD	
36HWK	36SHWX		
48HWK	48SHWX		
60HWK	60SHWX		
90HWK	90SHWX	1-1/8" OD	
120HWK	120SHWX	1-3/8" OD	

4. Discharge plenum with four way double - deflection louver (field installed)

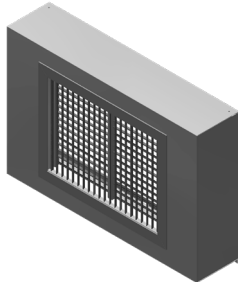
DISCHARGE PLENUM – DATA			
PART NUMBER	FOR UNIT MODEL	DEPTH (1)	RENDER
24DP	24SHWX	6"	
36DP	36SHWX		
48DP	48SHWX		
60DP	60SHWX		
90DP	90SHWX		
120DP	120SHWX		

(1) Height and width are the same as the unit being attached to.

# SHWX SERIES

DIRECT DRIVE HORIZONTAL 0-10V DC INPUT CONTROLLED UNIT

## OPTIONS (CONT'D)

DISCHARGE PLENUM – DIMENSIONS

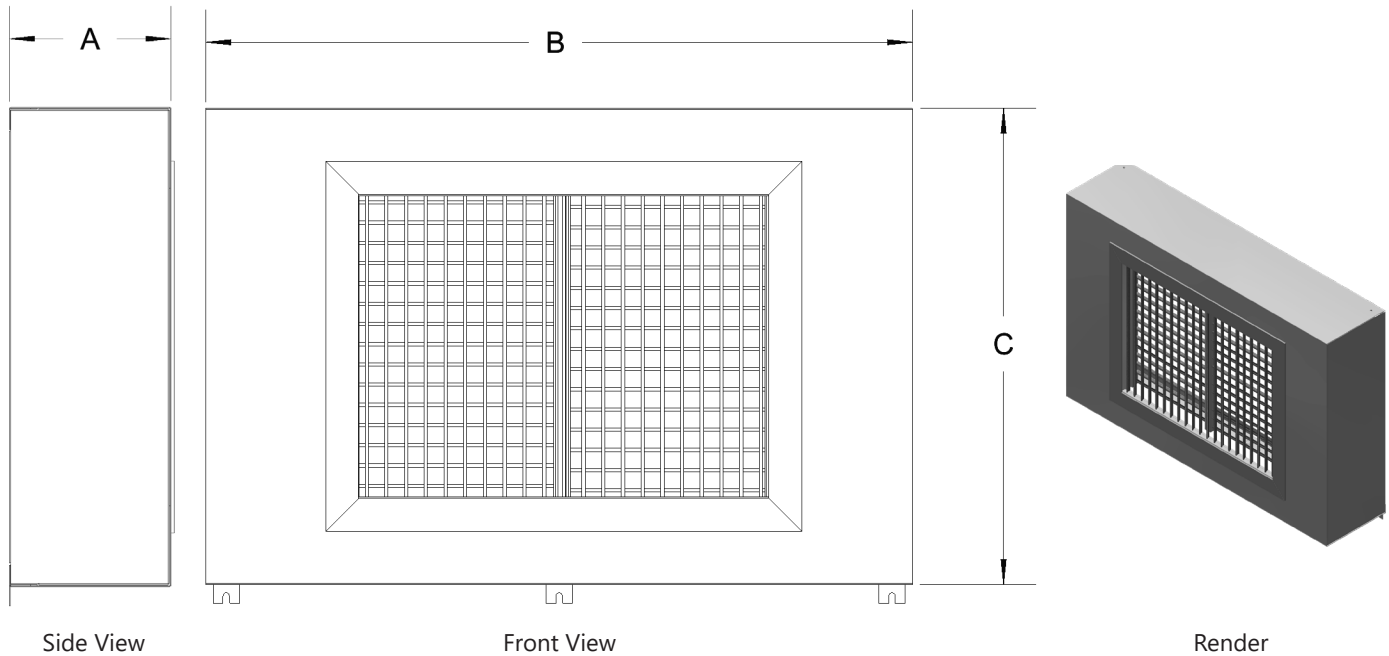

SHWX – DISCHARGE PLENUM DIMENSIONS							
Part Number	For UNIT Model	A	B	C	LOUVER SIZE	LOUVER PART NO.	SHIPPING WEIGHT LBS.
977-1*	24 SHWX	6.07	26.89	18.11	12" x 16"	G1612	20
977-2*	36 SHWX	6.07	36.39	18.11	12" x 24"	G2412	24
977-3*	48 SHWX	6.07	37.89	22.10	14" x 28"	G2814	27
977-4*	60 SHWX	6.07	44.89	22.10	14" x 34"	G3414	31
977-5*	90 SHWX	6.07	53.89	26.23	18" x 40"	G4018	35
977-6*	120 SHWX	6.07	56.89	31.23	22" x 46"	G4622	39
977-7*	180 SHWX	6.07	65.89	38.73	30" x 48"	G4830	43
977-8*	240 SHWX	6.07	65.89	51.23	40" x 48"	G4840	47

\* = INSULATION OPTION CODE (I,F,G)

# SHWX SERIES

DIRECT DRIVE HORIZONTAL 0-10V DC INPUT CONTROLLED UNIT

## OPTIONS (CONT'D) MIXING BOX

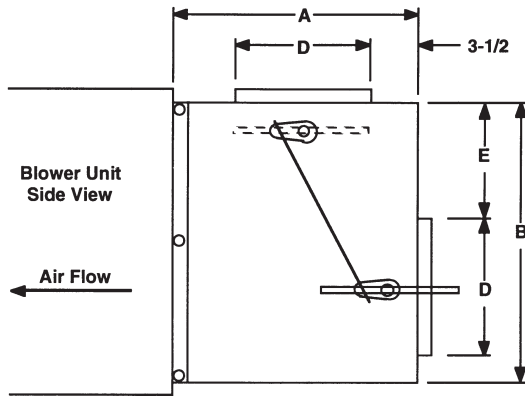

Mixing Box  
Side View

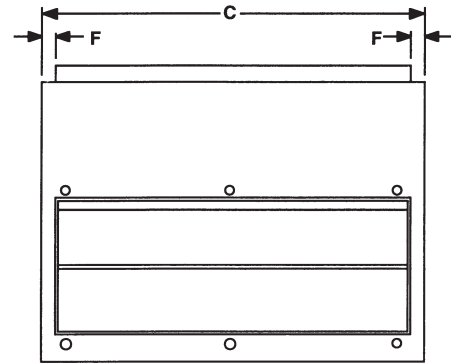

Mixing Box  
Rear View

## DIMENSIONS

SHWX – DIMENSIONS									
MODEL	FOR UNIT MODEL	A	B	C	D	E	F	DAMPER SIZE (NOM)	SHIPPING WEIGHT LBS.
24MB	24SH, SV	16	16-3/8	18-1/8	8	6	1-1/16	2-16 x 8	40
36MB	36SH, SV	16	16-3/8	27-5/8	8	6	1-1/16	2-26 x 8	58
48MB	48SH, SV	18	20-3/8	29-1/8	10	8	1-1/16	2-27 x 10	65
60MB	60SH, SV	18	20-3/8	36-1/8	10	8	1-1/16	2-34 x 10	78
90MB	90SH, SV	18	25-3/8	45-1/8	10	8	1-1/16	2-42 x 10	110
120MB	120SH, SV	20	30-3/8	48-1/8	12	10	1-1/16	2-46 x 12	135

## FEATURES

- Cabinet fully insulated - 3/4 inch.
- Embossed galvanized cabinet on 24-120MB.
- Crank arms and linkage rod for damper connection are furnished. Connections can be made on either side of mixing boxes. The balance of necessary linkage hardware, damper motor, and controls to be field supplied.
- Dampers can be positioned for either rear/top or rear/bottom locations.
- 1" duct flanges provided on damper openings.
- Dampers have air seals on the edges for positive closing. 24-90MB have single horizontal damper blades. 120MB have double horizontal damper blades.
- When used with water coil units, a "freezestat" must be installed to prevent coil damage caused by low ambient conditions.

# SHWX SERIES

DIRECT DRIVE HORIZONTAL 0-10V DC INPUT CONTROLLED UNIT

## COMPONENT STATIC RESISTANCE

SHWX – STATIC RESISTANCE								
MODEL	NOMINAL CFM	COMPONENT STATIC RESISTANCE (INCHES OF WATER)						
		CABINET	COOLING COIL*		HEATING COIL	STANDARD FILTER	MERV 11	MERV 13
			4 ROW	6 ROW	2 ROW			
24SHWX	600	0.09	0.14	0.22	0.07	0.04	0.24	0.32
	700	0.10	0.18	0.27	0.09	0.05		
	800	0.11	0.23	0.34	0.12	0.06		
	900	0.12	0.28	0.42	0.14	0.07		
	1000	0.13	0.33	0.50	0.18	0.08		
36SHWX	1000	0.09	0.17	0.25	0.08	0.04	0.24	0.32
	1100	0.10	0.19	0.28	0.10	0.05		
	1200	0.11	0.23	0.34	0.12	0.06		
	1300	0.12	0.26	0.39	0.13	0.07		
	1400	0.13	0.30	0.45	0.15	0.08		
48SHWX	1400	0.09	0.18	0.27	0.09	0.05	0.24	0.32
	1500	0.10	0.20	0.31	0.10	0.06		
	1600	0.11	0.23	0.34	0.11	0.06		
	1700	0.12	0.25	0.38	0.12	0.07		
	1800	0.13	0.28	0.42	0.13	0.08		
60SHWX	1800	0.10	0.20	0.28	0.09	0.05	0.24	0.32
	1900	0.11	0.21	0.31	0.10	0.06		
	2000	0.12	0.23	0.34	0.11	0.06		
	2100	0.13	0.25	0.37	0.12	0.07		
	2200	0.15	0.28	0.40	0.13	0.08		
90SHWX	2500	0.12	0.26	0.39	0.13	0.04	0.24	0.32
	2750	0.14	0.30	0.45	0.16	0.05		
	3000	0.16	0.34	0.51	0.18	0.06		
	3250	0.17	0.39	0.58	0.21	0.07		
	3500	0.19	0.44	0.65	0.24	0.08		
120SHWX	3400	0.14	0.29	0.43	0.14	0.05	0.24	0.32
	3700	0.15	0.33	0.48	0.16	0.06		
	4000	0.17	0.37	0.54	0.19	0.07		
	4300	0.19	0.41	0.61	0.21	0.08		
	4600	0.21	0.45	0.67	0.24	0.09		

\* Wet Coil (Dry Coil P.D. = Wet P.D. x .70)



SHWX

# SHWX SERIES

DIRECT DRIVE HORIZONTAL 0-10V DC INPUT CONTROLLED UNIT

## BLOWER DATA

### 24SHWX

TORQUE (%)	STATIC PRESSURE	CFM
100%	0.90	924
10.00	0.80	929
VDC	0.70	934
	0.60	939
	0.50	941
	0.30	956
80%	0.10	944
8.00	0.50	805
VDC	0.30	814
	0.10	802
	0.50	662
	0.30	659
60%	0.10	655
6.00	0.50	513
VDC	0.30	520
	0.10	507
	0.50	357
	0.30	375
40%	0.10	372
4.00	0.70	888
VDC	0.60	912
	0.50	935
	0.40	957
	0.30	978
	0.20	998
	0.10	1017
	0.00	1036
20%	0.13	537
2.00	0.10	544
VDC	0.00	582

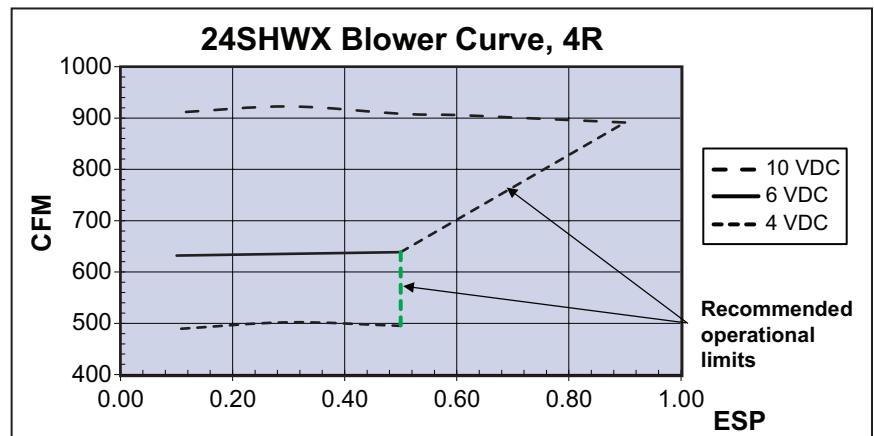
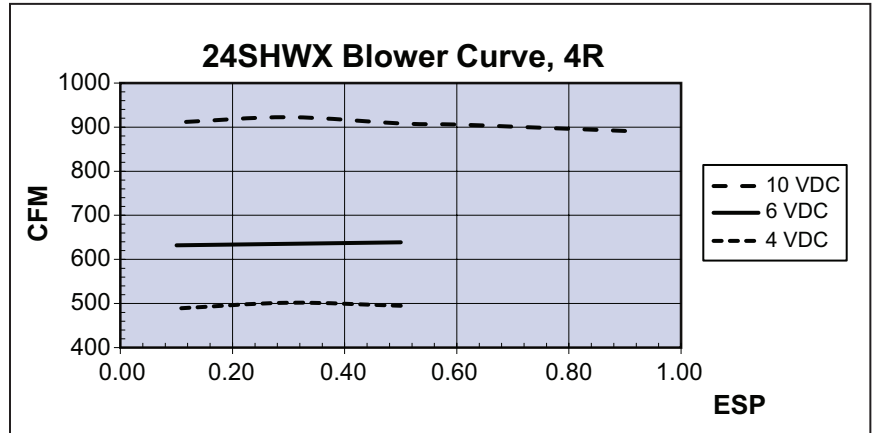

**NOTE:**

The recommended range is between 600-1000 CFM. The range can be lower if measures are made to prevent the coil from freezing.

# SHWX SERIES

DIRECT DRIVE HORIZONTAL 0-10V DC INPUT CONTROLLED UNIT

## BLOWER DATA

### 36SHWX

TORQUE (%)	STATIC PRESSURE	CFM
100%	1.80	274
10.00	1.60	488
VDC	1.20	817
	0.80	1297
	0.40	1387
	0.00	1313
80%	1.75	263
8.00	1.60	441
VDC	1.20	757
	0.80	1226
	0.40	1234
	0.00	1155
60%	1.65	253
6.00	1.60	340
VDC	1.20	693
	0.80	1052
	0.40	1060
	0.00	965
40%	1.55	246
4.00	1.20	631
VDC	0.80	836
	0.40	864
	0.15	842
20%	1.53	252
2.00	1.20	628
VDC	0.80	834
	0.40	861
	0.15	842

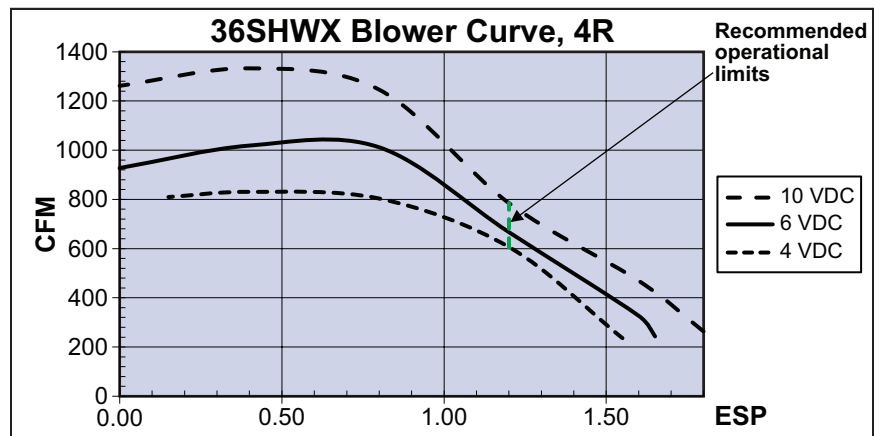
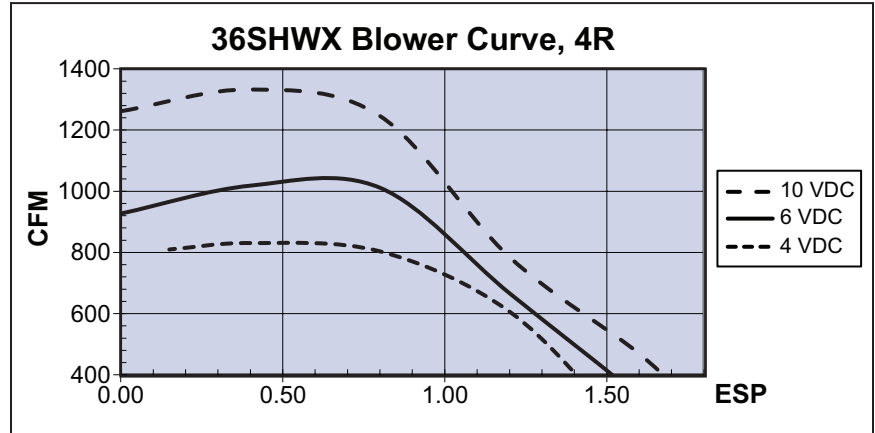

**NOTE:**

The recommended range is between 1000-1400 CFM. The range can be lower if measures are made to prevent the coil from freezing.

# SHWX SERIES

DIRECT DRIVE HORIZONTAL 0-10V DC INPUT CONTROLLED UNIT

## BLOWER DATA

### 48SHWX

TORQUE (%)	STATIC PRESSURE	CFM
100%	1.70	450
10.00	1.60	536
VDC	1.20	1360
	0.80	1346
	0.40	1708
	0.00	1689
80%	1.53	431
8.00	1.20	842
VDC	0.80	1266
	0.40	1431
	0.00	1418
60%	1.41	426
6.00	1.20	657
VDC	0.80	1061
	0.40	1103
	0.00	1108
40%	0.80	668
4.00	0.40	756
VDC	0.00	772
20%	0.75	265
2.00	0.40	345
VDC	0.00	430

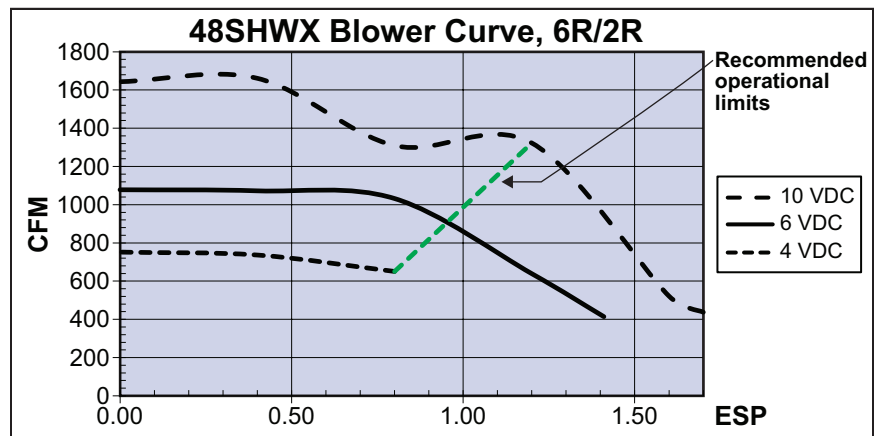
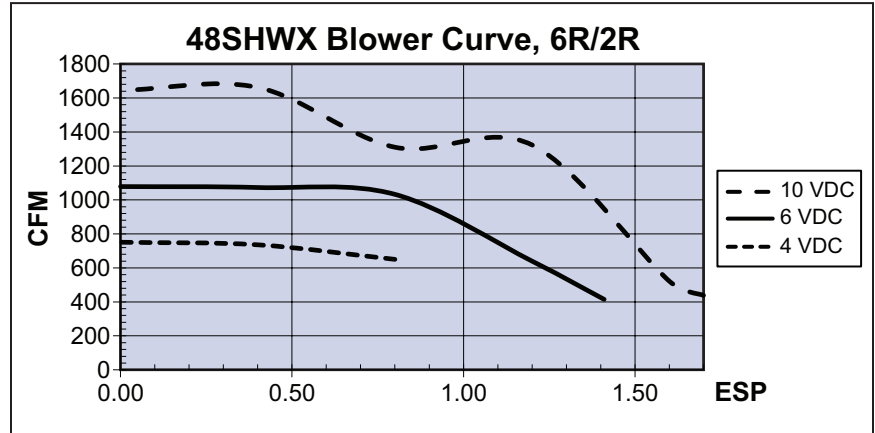

**NOTE:**

The recommended range is between 1400-1800 CFM. The range can be lower if measures are made to prevent the coil from freezing.

# SHWX SERIES

DIRECT DRIVE HORIZONTAL 0-10V DC INPUT CONTROLLED UNIT

## BLOWER DATA

### 60SHWX

TORQUE (%)	STATIC PRESSURE	CFM
100%	2.00	1507
10.00	1.60	1958
VDC	1.20	2199
	0.80	2310
	0.40	2360
	0.00	2373
80%	2.00	1166
8.00	1.60	1750
VDC	1.20	1965
	0.80	1973
	0.40	1980
	0.00	1995
60%	2.00	645
6.00	1.60	1346
VDC	1.20	1552
	0.80	1579
	0.40	1591
	0.00	1583
40%	1.90	474
4.00	1.60	942
VDC	1.20	1111
	0.80	1155
	0.40	1173
	0.00	1155
20%	1.60	514
2.00	1.20	547
VDC	0.80	716
	0.40	776
	* 0.00	703

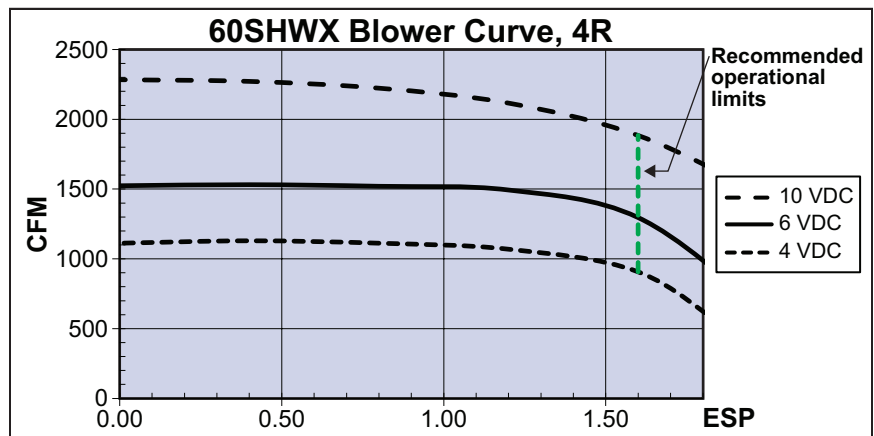
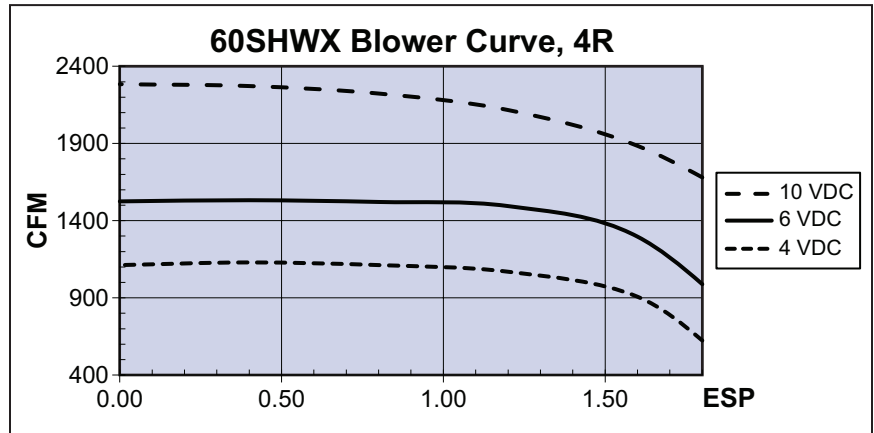

**NOTE:**

The recommended range is between 1800-2200 CFM. The range can be lower if measures are made to prevent the coil from freezing.

# SHWX SERIES

DIRECT DRIVE HORIZONTAL 0-10V DC INPUT CONTROLLED UNIT

## BLOWER DATA

### 90SHWX

TORQUE (%)	STATIC PRESSURE	CFM
100%	2.20	4032
10.00	2.00	4131
VDC	1.60	4282
	1.20	4381
	0.80	4533
	0.40	4725
6.2VDC	2.00	3523
	1.60	3713
	1.20	3879
	0.80	4046
	0.40	4219
	0.00	4378
5.8VDC	2.00	3272
	1.60	3471
	1.20	3632
	0.80	3846
	0.40	4013
	0.00	4135
5.3VDC	2.00	3031
	1.60	3224
	1.20	3354
	0.80	3580
	0.40	3783
	0.00	3915
4.8VDC	2.00	2538
	1.60	2881
	1.20	2686
	0.80	2864
	0.40	2981
	0.00	3198

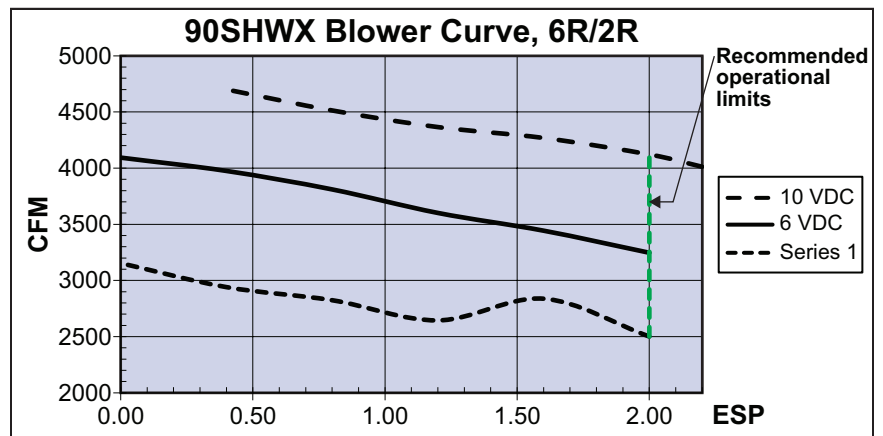
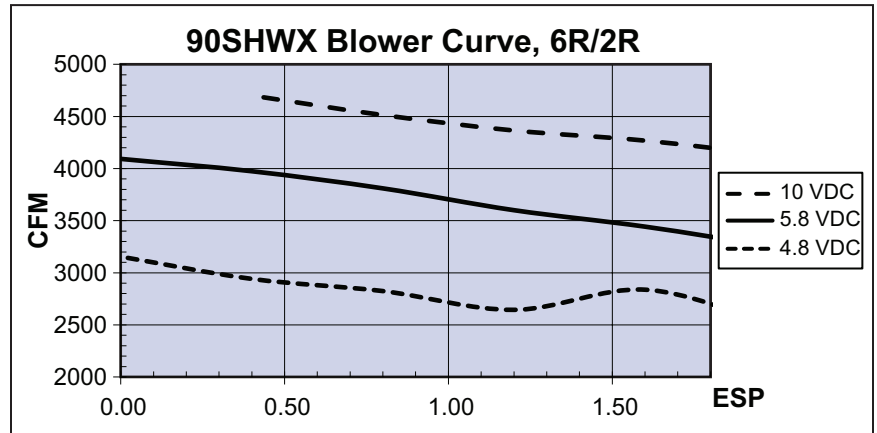

**NOTE:**

The recommended range is between 2500-3500 CFM. The range can be lower if measures are made to prevent the coil from freezing.

# SHWX SERIES

DIRECT DRIVE HORIZONTAL 0-10V DC INPUT CONTROLLED UNIT

## BLOWER DATA

### 120SHWX

TORQUE (%)	STATIC PRESSURE	CFM
100%	2.00	6125
10.00	1.60	6280
VDC	1.20	6423
	0.80	6563
	0.40	6699
	0.00	6824
6.2VDC	2.00	4709
	1.60	4904
	1.20	5054
	0.80	5252
	0.40	5413
	0.00	5519
5.75VDC	2.00	4415
	1.60	4582
	1.20	4778
	0.80	4996
	0.40	5178
	0.00	5333
5.3VDC	2.20	3606
	2.00	3749
	1.60	4246
	1.20	4420
	0.80	4624
	0.40	4768
5.0VDC	2.00	3474
	1.60	3975
	1.20	4191
	0.80	4387
	0.40	4535
	0.00	4695

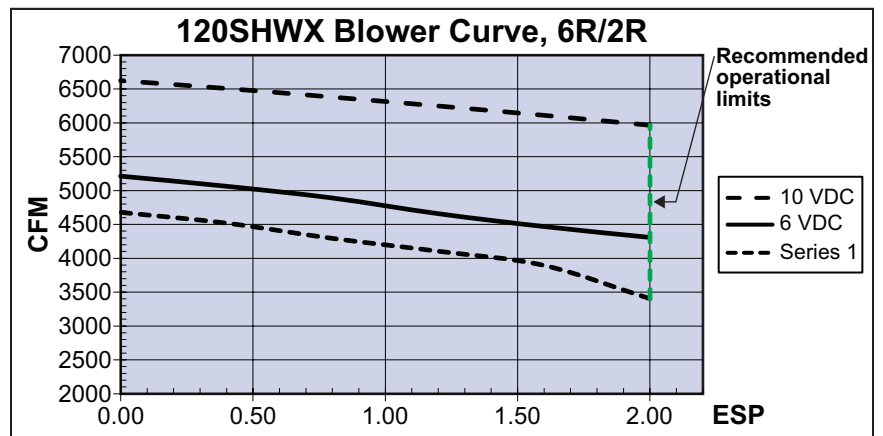
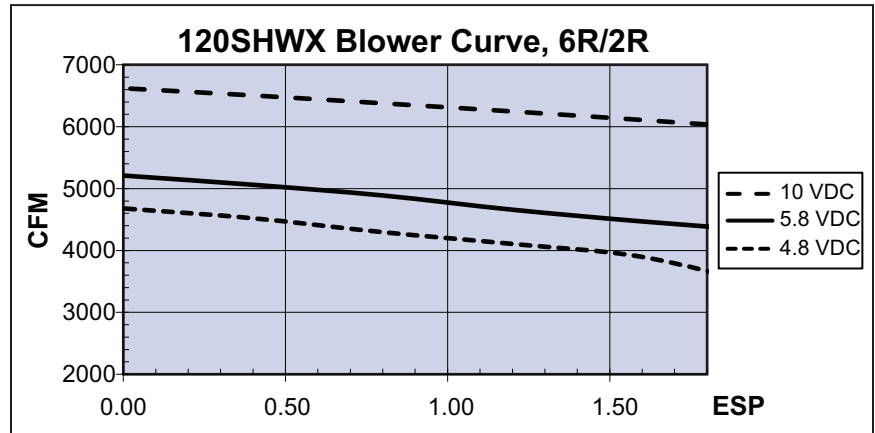

**NOTE:**

The recommended range is between 34,500-4600 CFM. The range can be lower if measures are made to prevent the coil from freezing.

# SHWX SERIES

DIRECT DRIVE HORIZONTAL 0-10V DC INPUT CONTROLLED UNIT

## CHILLED WATER COOLING CAPACITIES – 24SHWX

24SHWX – CHILLED WATER CAPACITIES																		
ENT. WTR. °F	C.F.M.	24SHWX4 (4 ROW COIL)								24SHWX6 (6 ROW COIL)								
		G. P. M.	WTR. P.D. FT.	80°F DB/67°F WB ENT. AIR			75°F DB/63°F WB ENT. AIR			G. P. M.	WTR. P.D. FT.	80°F DB/67°F WB ENT. AIR			75°F DB/63°F WB ENT. AIR			
				TOTAL MBH	SENS. MBH	TEMP. RISE	TOTAL MBH	SENS. MBH	TEMP. RISE			TOTAL MBH	SENS. MBH	TEMP. RISE	TOTAL MBH	SENS. MBH	TEMP. RISE	
42°F	600	3.0	1.2	19.6	13.9	13.0	14.9	12.1	9.9	3.0	1.3	22.3	15.7	14.9	17.0	13.6	11.4	
	800			21.7	16.5	14.5	16.6	14.5	11.0			24.9	18.8	16.6	19.0	16.5	12.7	
	1000			23.2	18.7	15.5	17.7	16.6	11.8			26.7	21.6	17.8	20.4	19.1	13.6	
	600	6.0	4.4	24.8	15.9	8.3	18.9	13.7	6.3	5.0	3.3	26.9	17.5	10.8	20.6	15.0	8.2	
	800			29.0	19.2	9.7	22.2	16.7	7.4			31.3	21.2	12.5	24.0	18.4	9.6	
	1000			32.5	22.1	10.8	24.8	19.3	8.3			34.9	24.6	13.9	26.6	21.5	10.7	
600	9.0	9.3	26.7	16.6	5.9	20.4	14.3	4.5	7.0	6.1	29.6	18.5	8.4	22.6	15.9	6.4		
800			31.8	20.3	7.1	24.3	17.6	5.4			35.2	22.8	10.0	26.9	19.6	7.7		
1000			36.3	23.6	8.1	27.7	20.4	6.2			39.8	26.5	11.4	30.4	23.0	8.7		
45°F	600	3.0	1.2	17.9	13.3	12.0	13.7	11.6	9.1	3.0	1.3	20.5	14.9	13.7	15.6	13.1	10.4	
	800			19.9	15.8	13.3	15.2	14.0	10.1			22.8	18.0	15.2	17.4	15.9	11.6	
	1000			21.3	18.1	14.2	17.5	17.5	11.7			24.5	20.8	16.4	21.4	21.4	14.2	
	600	6.0	4.4	22.7	15.1	7.6	17.4	13.1	5.8	5.0	3.3	24.7	16.6	9.9	18.9	14.3	7.5	
	800			26.6	18.3	8.9	20.3	16.0	6.8			28.7	20.2	11.5	22.0	17.6	8.8	
	1000			29.8	21.1	9.9	22.7	18.5	7.6			32.0	23.5	12.8	24.4	20.6	9.8	
600	9.0	9.3	24.5	15.8	5.4	18.7	13.6	4.2	7.0	6.1	27.1	17.5	7.7	20.7	15.1	5.9		
800			29.2	19.3	6.5	22.3	16.8	5.0			32.3	21.6	9.2	24.6	18.7	7.0		
1000			33.3	22.5	7.4	25.4	19.5	5.6			36.5	25.2	10.4	27.9	22.0	8.0		
50°F	600	3.0	1.2	15.2	12.3	10.2	11.6	10.9	7.8	3.0	1.3	17.4	13.8	11.6	13.3	12.2	8.9	
	800			16.9	14.8	11.3	12.8	12.8	8.6			19.4	16.8	12.9	15.6	15.6	10.4	
	1000			18.1	17.0	12.1	14.6	14.6	9.7			20.9	19.5	13.9	17.8	17.8	11.9	
	600	6.0	4.4	19.3	13.8	6.4	14.7	12.0	4.9	5.0	3.3	21.0	15.1	8.4	16.0	13.2	6.4	
	800			22.6	16.8	7.5	17.3	14.8	5.8			24.4	18.6	9.8	18.7	16.3	7.5	
	1000			25.3	19.5	8.4	19.3	17.2	6.4			27.2	21.7	10.9	20.8	19.2	8.3	
600	9.0	9.3	20.8	14.3	4.6	15.9	12.5	3.5	7.0	6.1	23.1	15.9	6.6	17.6	13.8	5.0		
800			24.8	17.6	5.5	19.0	15.5	4.2			27.4	19.7	7.8	20.9	17.2	6.0		
1000			28.3	20.6	6.3	21.6	18.1	4.8			31.1	23.2	8.9	23.7	20.3	6.8		

## HOT WATER HEATING CAPACITIES – 24SHWX

24SHWX4 (4 ROW COIL)					
180°F ENTERING WATER TEMPERATURE					
CFM	GPM	WTR. P.D. FT.	TOTAL MBH	LVG. AIR°F	LVG. WTR°F
600	3.0	1.2	47.5	143	148
800			56.4	135	142
1000			64.3	130	137
600	6.0	4.4	52.0	150	163
800			63.2	143	159
1000			73.3	138	156
600	9.0	9.3	53.6	153	168
800			65.8	146	165
1000			76.8	141	163

\* 70°F return air

**NOTES:**

- 1) See last page for Hot Water Heating Correction Factors.
- 2) Optional 6 row coils should not be used for heating.
- 3) Optional 2 row hot water coils can be factory or field installed.
- 4) When these units are used for hot water heating the leaving air temperature must not exceed 150°F. At high altitude conditions, blower motor may cutout at a lower LAT. Contact factory for information.

24SHWX6 (6 ROW COIL)					
180°F ENTERING WATER TEMPERATURE					
CFM	GPM	WTR. P.D. FT.	TOTAL MBH	LVG. AIR°F	LVG. WTR°F
600	3.0	0.9	33.3	121	158
800			38.4	115	154
1000			42.9	110	151
600	6.0	3.2	36.6	126	168
800			43.2	120	166
1000			49.0	115	164
600	9.0	6.7	37.9	128	172
800			45.3	122	170
1000			51.8	118	168

\* 70°F return air

# SHWX SERIES

DIRECT DRIVE HORIZONTAL 0-10V DC INPUT CONTROLLED UNIT

## CHILLED WATER COOLING CAPACITIES – 36SHWX

36SHWX – CHILLED WATER CAPACITIES																			
ENT. WTR. °F	C. F. M.	36SHWX4 (4 ROW COIL)								36SHWX6 (6 ROW COIL)									
		G. P. M.	WTR. P.D. FT.	80°F DB/67°F WB ENT. AIR			75°F DB/63°F WB ENT. AIR			G. P. M.	WTR. P.D. FT.	80°F DB/67°F WB ENT. AIR			75°F DB/63°F WB ENT. AIR				
				TOTAL MBH	SENS. MBH	TEMP. RISE	TOTAL MBH	SENS. MBH	TEMP. RISE			TOTAL MBH	SENS. MBH	TEMP. RISE	TOTAL MBH	SENS. MBH	TEMP. RISE		
42°F	1000	4.0	2.0	29.6	21.9	14.8	22.6	19.2	11.3	4.0	2.7	35.6	25.4	17.8	27.2	22.1	13.6		
	1200			31.4	24.4	15.7	24.0	21.5	12.0			38.0	28.4	19.0	29.1	25.0	14.5		
	1400			33.1	26.7	16.6	25.3	23.7	12.7			40.5	31.5	20.2	30.9	27.7	15.5		
	45°F	1000	8.0	7.5	39.0	25.4	9.8	29.8	22.0	7.4	7.0	7.5	45.0	29.0	12.9	34.4	25.0	9.8	
		1200			43.0	28.7	10.7	32.8	24.9	8.2			49.7	33.0	14.2	38.0	28.5	10.8	
		1400			46.5	31.6	11.6	35.5	27.6	8.9			53.9	36.6	15.4	41.2	31.8	11.8	
		45°F	600	12.0	16.3	42.6	26.8	7.1	32.5	23.1	5.4	10.0	14.5	49.5	31.0	9.9	37.8	26.5	7.6
			800			47.5	30.4	7.9	36.3	26.3	6.0			55.5	35.3	11.1	42.4	30.3	8.5
			1000			52.0	33.7	8.7	39.7	29.2	6.6			60.9	39.3	12.2	46.5	33.9	9.3
50°F			1000	4.0	2.0	27.2	21.0	13.6	21.7	18.5	10.4	4.0	2.7	32.6	24.2	16.3	24.9	21.3	12.5
			1200			28.8	23.4	14.4	22.0	20.7	11.0			34.9	27.3	17.4	26.7	24.0	13.3
			1400			30.4	25.8	15.2	25.0	25.0	12.5			37.1	30.3	18.6	28.4	26.8	14.2
	50°F		1000	8.0	7.5	35.8	24.2	8.9	27.3	21.0	6.8	7.0	7.5	41.3	27.6	11.8	31.5	23.9	9.0
			1200			39.4	27.3	9.9	30.1	23.9	7.5			45.6	31.3	13.0	34.8	27.2	10.0
			1400			42.6	30.2	10.7	32.6	26.4	8.1			49.5	34.9	14.1	37.8	30.4	10.8
		50°F	600	12.0	16.3	39.0	25.5	6.5	29.8	22.0	5.0	10.0	14.5	45.4	29.2	9.1	34.7	25.2	6.9
			800			43.6	28.9	7.3	33.3	25.1	5.5			50.9	33.4	10.2	38.9	28.9	7.8
			1000			47.7	32.1	7.9	36.4	27.9	6.1			55.9	37.3	11.2	42.7	32.3	8.5
50°F			1000	4.0	2.0	23.1	19.5	11.5	17.2	17.2	8.6	4.0	2.7	27.7	22.4	13.9	21.2	19.8	10.6
			1200			24.5	21.9	12.2	19.1	19.1	9.5			29.7	25.4	14.8	23.6	23.6	11.8
			1400			25.8	24.2	12.9	20.8	20.8	10.4			31.6	28.3	15.8	26.0	26.0	13.0
	50°F		1000	8.0	7.5	30.4	22.2	7.6	23.2	19.4	5.8	7.0	7.5	35.1	25.2	10.0	26.8	22.0	7.7
			1200			33.5	25.1	8.4	25.6	22.1	6.4			38.8	28.7	11.1	29.6	25.2	8.5
			1400			36.2	27.9	9.1	27.7	24.6	6.9			42.1	32.1	12.0	32.1	28.2	9.2
		50°F	600	12.0	16.3	33.2	23.2	5.5	25.3	20.3	4.2	10.0	14.5	38.6	26.5	7.7	29.5	23.1	5.9
			800			37.1	26.4	6.2	28.3	23.2	4.7			43.3	30.4	8.7	33.0	26.5	6.6
			1000			40.5	29.4	6.8	31.0	25.8	5.2			47.5	34.1	9.5	36.3	29.8	7.3

## HOT WATER HEATING CAPACITIES – 36SHWX

36SHWX4 (4 ROW COIL)					
180°F ENTERING WATER TEMPERATURE					
CFM	GPM	WTR. P.D. FT.	TOTAL MBH	LVG. AIR°F	LVG. WTR°F
1000	4.0	2.0	75.5	140	142
1200			83.9	135	138
1400			91.7	131	134
1000	8.0	7.5	83.9	148	159
1200			94.7	143	156
1400			105.1	140	154
1000	12.0	16.3	86.8	150	165
1200			98.9	146	163
1400			110.1	143	162

\* 70°F return air

**NOTES:**

- 1) See last page for Hot Water Heating Correction Factors.
- 2) Optional 6 row coils should not be used for heating.
- 3) Optional 2 row hot water coils can be factory or field installed.
- 4) When these units are used for hot water heating the leaving air temperature must not exceed 150°F. At high altitude conditions, blower motor may cutout at a lower LAT. Contact factory for information.

36SHWX6 (6 ROW COIL)					
180°F ENTERING WATER TEMPERATURE					
CFM	GPM	WTR. P.D. FT.	TOTAL MBH	LVG. AIR°F	LVG. WTR°F
1000	4.0	1.6	53.3	119	153
1200			58.7	115	150
1400			65.4	112	148
1000	8.0	6.1	59.4	125	165
1200			66.2	121	164
1400			72.5	118	162
1000	12.0	13.1	61.5	127	170
1200			68.7	123	168
1400			75.4	120	167

\* 70°F return air

# SHWX SERIES

DIRECT DRIVE HORIZONTAL 0-10V DC INPUT CONTROLLED UNIT

## CHILLED WATER COOLING CAPACITIES – 48SHWX

48SHWX – CHILLED WATER CAPACITIES																		
ENT. WTR. °F	C.F.M.	48SHWX4 (4 ROW COIL)									48SHWX6 (6 ROW COIL)							
		G. P. M.	WTR. P.D. FT.	80°F DB/67°F WB ENT. AIR			75°F DB/63°F WB ENT. AIR			G. P. M.	WTR. P.D. FT.	80°F DB/67°F WB ENT. AIR			75°F DB/63°F WB ENT. AIR			
				TOTAL MBH	SENS. MBH	TEMP. RISE	TOTAL MBH	SENS. MBH	TEMP. RISE			TOTAL MBH	SENS. MBH	TEMP. RISE	TOTAL MBH	SENS. MBH	TEMP. RISE	
42°F	1400	6.0	3.9	42.9	31.0	14.3	32.8	27.2	10.9	5.0	2.3	45.6	33.8	18.2	34.8	29.6	13.9	
	1600			45.1	33.6	15.0	34.5	29.6	11.5			47.5	36.7	19.0	36.3	32.3	14.5	
	1800			46.5	35.9	15.5	35.5	31.6	11.8			48.7	39.3	19.5	37.2	34.7	14.9	
	1400	10.0	10.3	52.6	34.7	10.5	40.2	30.1	8.0	8.0	5.5	57.0	38.2	14.2	43.5	33.1	10.9	
	1600			56.4	37.9	11.3	43.1	32.9	8.6			60.7	41.7	15.2	46.3	36.2	11.6	
	1800			59.7	40.7	11.9	45.6	35.5	9.1			63.7	44.9	15.9	48.7	39.2	12.2	
	1400	13.0	17.0	56.3	36.1	8.7	43.0	31.2	6.6	11.0	10.1	63.6	40.9	11.6	48.6	35.2	8.8	
	1600			60.8	39.6	9.4	46.5	34.3	7.1			68.6	44.8	12.5	52.4	38.7	9.5	
	1800			65.0	42.8	10.0	49.6	37.1	7.6			73.1	48.5	13.3	55.8	42.0	10.1	
45°F	1400	6.0	3.9	39.4	29.7	13.1	30.1	26.1	10.0	5.0	2.3	41.8	32.4	16.7	31.9	28.5	12.8	
	1600			41.4	32.3	13.8	31.6	28.5	10.5			43.6	35.3	17.4	33.3	31.2	13.3	
	1800			42.6	34.5	14.2	32.6	30.5	10.9			44.7	37.8	17.9	39.6	39.6	15.8	
	1400	10.0	10.3	48.3	33.0	9.7	36.9	28.8	7.4	8.0	5.5	52.3	36.4	13.1	39.9	31.7	10.0	
	1600			51.8	36.1	10.4	39.5	31.5	7.9			55.7	39.8	13.9	42.5	34.7	10.6	
	1800			54.7	38.9	10.9	41.8	34.1	8.4			58.4	42.9	14.6	44.6	37.6	11.2	
	1400	13.0	17.0	51.6	34.3	7.9	39.4	29.8	6.1	11.0	10.1	58.4	38.8	10.6	44.6	33.5	8.1	
	1600			55.8	37.6	8.6	42.6	32.7	6.6			63.0	42.6	11.4	48.1	36.9	8.7	
	1800			59.6	40.7	9.2	45.5	35.5	7.0			67.0	46.2	12.2	51.2	40.2	9.3	
50°F	1400	6.0	3.9	33.5	27.6	11.2	24.2	24.2	8.1	5.0	2.3	35.5	30.2	14.2	28.4	28.4	11.4	
	1600			35.2	30.1	11.7	26.1	26.1	8.7			37.1	32.9	14.6	30.7	30.7	12.3	
	1800			36.2	32.2	12.1	28.0	28.0	9.3			38.0	35.5	15.2	33.0	33.0	13.2	
	1400	10.0	10.3	41.0	30.3	8.2	31.3	26.6	6.3	8.0	5.5	44.4	33.4	11.1	33.9	29.3	8.5	
	1600			44.0	33.2	8.8	33.6	29.3	6.7			47.3	36.6	11.8	36.1	32.3	9.0	
	1800			46.5	35.9	9.3	35.5	31.7	7.1			49.7	39.7	12.4	37.9	35.0	9.5	
	1400	13.0	17.0	43.9	31.4	6.8	33.5	27.5	5.2	11.0	10.1	49.6	35.4	9.0	37.9	30.9	6.9	
	1600			47.4	34.5	7.3	36.2	30.3	5.6			53.5	39.0	11.8	40.9	34.1	7.4	
	1800			50.7	37.4	7.8	38.7	32.9	6.0			57.0	42.4	10.4	43.5	37.2	7.9	

## HOT WATER HEATING CAPACITIES – 48SHWX

48SHWX4 (4 ROW COIL)					
180°F ENTERING WATER TEMPERATURE					
CFM	GPM	WTR. P.D. FT.	TOTAL MBH	LVG. AIR°F	LVG. WTR°F
1400	6.0	3.9	106.3	140	145
1600			114.9	137	142
1800			123.3	133	139
1400	10.0	10.3	114.9	146	157
1600			125.3	143	155
1800			135.3	140	153
1400	13.0	17.0	118.0	148	162
1600			129.4	145	160
1800			140.0	142	158

\* 70°F return air

**NOTES:**

- 1) See last page for Hot Water Heating Correction Factors.
- 2) Optional 6 row coils should not be used for heating.
- 3) Optional 2 row hot water coils can be factory or field installed.
- 4) When these units are used for hot water heating the leaving air temperature must not exceed 150°F. At high altitude conditions, blower motor may cutout at a lower LAT. Contact factory for information.

48SHWX6 (6 ROW COIL)					
180°F ENTERING WATER TEMPERATURE					
CFM	GPM	WTR. P.D. FT.	TOTAL MBH	LVG. AIR°F	LVG. WTR°F
1400	5.0	2.0	72.8	118	151
1600			78.0	115	149
1800			82.7	113	147
1400	8.0	4.8	79.2	122	160
1600			85.4	119	159
1800			91.4	117	157
1400	12.0	10.4	83.3	125	166
1600			90.2	122	165
1800			97.0	120	164

\* 70°F return air

# SHWX SERIES

DIRECT DRIVE HORIZONTAL 0-10V DC INPUT CONTROLLED UNIT

## CHILLED WATER COOLING CAPACITIES – 60SHWX

60SHWX – CHILLED WATER CAPACITIES																		
ENT. WTR. °F	C.F.M.	60SHWX4 (4 ROW COIL)									60SHWX6 (6 ROW COIL)							
		G. P. M.	WTR. P.D. FT.	80°F DB/67°F WB ENT. AIR			75°F DB/63°F WB ENT. AIR			G. P. M.	WTR. P.D. FT.	80°F DB/67°F WB ENT. AIR			75°F DB/63°F WB ENT. AIR			
				TOTAL MBH	SENS. MBH	TEMP. RISE	TOTAL MBH	SENS. MBH	TEMP. RISE			TOTAL MBH	SENS. MBH	TEMP. RISE	TOTAL MBH	SENS. MBH	TEMP. RISE	
42°F	1800	6.0	1.8	48.7	37.4	16.2	37.2	33.0	12.4	6.0	1.6	57.5	43.0	19.2	43.9	37.7	14.6	
	2000			49.0	39.3	16.3	37.4	34.8	12.5			57.8	45.3	19.3	44.2	39.9	14.7	
	2200			49.6	41.3	16.5	43.1	43.1	14.4			58.8	47.8	19.6	44.9	42.3	15.0	
	1800	11.0	5.7	63.6	43.0	11.6	48.6	37.4	8.8	9.0	3.4	69.6	47.6	15.5	53.2	41.4	11.8	
	2000			66.7	45.9	12.1	50.9	40.0	9.3			72.1	50.7	16.0	55.1	44.2	12.2	
	2200			69.4	48.5	12.6	53.0	42.4	9.6			74.6	53.7	16.6	57.0	46.9	12.7	
1800	16.0	11.6	70.6	45.7	8.8	53.9	39.5	6.7	12.0	5.9	77.3	50.7	12.9	59.1	43.8	9.8		
2000			75.3	49.1	9.4	57.5	42.6	7.2			81.5	54.3	13.6	62.3	47.0	10.4		
2200			79.4	52.3	9.9	60.6	45.4	7.6			85.4	57.8	14.2	65.2	50.2	10.9		
45°F	1800	6.0	1.8	44.7	35.9	14.9	34.1	31.8	11.4	6.0	1.6	52.7	41.2	17.6	40.3	36.3	13.4	
	2000			45.0	37.9	15.0	37.1	37.8	12.4			53.1	43.6	17.7	40.5	38.5	13.5	
	2200			45.5	39.9	15.2	39.2	39.2	13.1			53.9	46.0	18.0	48.3	48.3	16.1	
	1800	11.0	5.7	58.4	41.0	10.6	44.6	35.8	8.1	9.0	3.4	63.8	45.4	14.2	48.8	39.6	10.8	
	2000			61.2	43.8	11.1	46.7	38.4	8.5			66.2	48.4	14.7	50.5	42.4	11.2	
	2200			63.7	46.4	11.6	48.6	40.7	8.8			68.5	51.4	15.2	52.3	45.1	11.6	
1800	16.0	11.6	64.8	43.4	8.1	49.5	37.7	6.2	12.0	5.9	71.0	48.2	11.8	54.2	41.8	9.0		
2000			69.1	46.7	8.6	52.7	40.7	6.6			74.8	51.7	12.5	57.1	45.0	9.5		
2200			72.9	49.8	9.1	55.6	43.5	7.0			78.3	55.1	13.1	59.8	48.0	10.0		
50°F	1800	6.0	1.8	38.0	33.6	12.7	29.1	29.1	9.7	6.0	1.6	44.8	38.3	14.9	35.5	35.5	11.8	
	2000			38.2	35.5	12.7	31.0	31.0	10.3			45.1	40.7	15.0	38.0	38.0	12.7	
	2200			39.2	39.2	13.1	32.7	32.7	10.9			45.8	43.2	15.3	40.2	40.2	13.4	
	1800	11.0	5.7	49.6	37.7	9.0	37.9	33.2	6.9	9.0	3.4	54.3	41.8	12.1	41.4	36.8	9.2	
	2000			52.0	40.4	9.5	39.7	35.7	7.2			56.2	44.7	12.5	43.0	39.5	9.5	
	2200			54.1	42.9	9.8	41.3	38.0	7.5			58.2	47.6	12.9	44.5	42.1	9.9	
1800	16.0	11.6	55.1	39.7	6.9	42.1	34.8	5.3	12.0	5.9	60.3	44.1	10.1	46.1	38.6	7.7		
2000			58.7	42.9	7.3	44.8	37.6	5.6			63.6	47.4	10.6	48.6	41.6	8.1		
2200			61.9	45.8	7.7	47.3	40.2	5.9			66.6	50.7	11.1	50.9	44.5	8.5		

## HOT WATER HEATING CAPACITIES – 60SHWX

60SHWX4 (4 ROW COIL)					
180°F ENTERING WATER TEMPERATURE					
CFM	GPM	WTR. P.D. FT.	TOTAL MBH	LVG. AIR°F	LVG. WTR°F
1800	6.0	1.8	128.0	136	137
2000			136.2	133	135
2200			143.8	131	132
1800	11.0	5.7	142.6	143	154
2000			152.9	141	152
2200			162.6	138	150
1800	16.0	11.6	149.6	147	161
2000			160.8	144	160
2200			171.4	142	159

\* 70°F return air

**NOTES:**

- 1) See last page for Hot Water Heating Correction Factors.
- 2) Optional 6 row coils should not be used for heating.
- 3) Optional 2 row hot water coils can be factory or field installed.
- 4) When these units are used for hot water heating the leaving air temperature must not exceed 150°F. At high altitude conditions, blower motor may cutout at a lower LAT. Contact factory for information.

60SHWX6 (6 ROW COIL)					
180°F ENTERING WATER TEMPERATURE					
CFM	GPM	WTR. P.D. FT.	TOTAL MBH	LVG. AIR°F	LVG. WTR°F
1800	6.0	3.1	93.1	118	149
2000			98.2	116	147
2200			103.1	113	145
1800	9.0	6.6	100.4	122	158
2000			106.5	119	156
2200			112.6	117	155
1800	12.0	11.5	104.4	124	163
2000			111.0	121	162
2200			117.7	120	160

\* 70°F return air

# SHWX SERIES

DIRECT DRIVE HORIZONTAL 0-10V DC INPUT CONTROLLED UNIT

## CHILLED WATER COOLING CAPACITIES – 90SHWX

90SHWX – CHILLED WATER CAPACITIES																	
ENT. WTR. °F	C.F.M.	90SHWX4 (4 ROW COIL)								90SHWX6 (6 ROW COIL)							
		G. P. M.	WTR. P.D. FT.	80°F DB/67°F WB ENT. AIR			75°F DB/63°F WB ENT. AIR			G. P. M.	WTR. P.D. FT.	80°F DB/67°F WB ENT. AIR			75°F DB/63°F WB ENT. AIR		
				TOTAL MBH	SENS. MBH	TEMP. RISE	TOTAL MBH	SENS. MBH	TEMP. RISE			TOTAL MBH	SENS. MBH	TEMP. RISE	TOTAL MBH	SENS. MBH	TEMP. RISE
42°F	2500	10.0	2.2	80.4	60.2	16.1	61.4	52.8	12.3	11	1.6	94.2	66.6	17.1	71.9	58.0	13.1
	3000			85.2	67.6	17.0	65.0	59.6	13.0			100.3	74.9	18.2	76.6	65.6	13.9
	3500			89.4	74.7	17.9	76.5	76.5	15.3			106.6	83.3	19.4	81.4	73.3	14.8
	2500	15.0	4.7	96.3	66.3	12.8	73.5	57.6	9.8	21	5.5	120.7	77.2	11.5	92.2	66.3	8.8
	3000			104.5	74.8	13.9	79.8	65.3	10.6			133.4	87.8	12.7	101.9	75.8	9.7
	3500			111.2	82.7	14.8	84.9	72.5	11.3			144.9	98.0	13.8	110.1	84.8	10.5
2500	22.0	9.8	108.1	71.0	9.8	82.6	61.3	7.5	31	11.5	133.3	82.4	8.6	101.8	70.3	6.6	
3000			119.3	80.6	10.8	91.1	69.8	8.3			149.6	94.4	9.6	114.2	80.9	7.4	
3500			128.8	89.4	11.7	98.3	77.8	8.9			164.1	105.7	10.6	125.3	90.9	8.1	
45°F	2500	10.0	2.2	73.8	57.8	14.8	56.3	50.9	11.3	11	1.6	86.4	63.6	15.7	66.0	55.7	12.0
	3000			78.1	65.0	15.6	63.4	63.4	12.7			92.0	71.8	16.7	70.3	63.2	12.8
	3500			82.0	72.0	16.4	69.6	69.6	13.9			97.8	80.0	17.8	74.7	70.7	13.6
	2500	15.0	4.7	88.3	63.3	11.8	67.5	55.2	9.0	21	5.5	110.8	73.2	10.6	84.6	63.1	8.1
	3000			95.8	71.6	12.8	73.2	62.8	9.8			122.4	83.4	11.7	93.5	72.3	8.9
	3500			102.0	79.3	13.6	77.9	69.8	10.4			132.9	93.3	12.7	101.5	81.2	9.7
2500	22.0	9.8	99.2	67.5	9.0	75.8	58.5	6.9	31	11.5	122.3	77.8	7.9	93.4	66.7	6.0	
3000			109.4	76.7	9.9	83.6	66.8	7.6			137.2	89.4	8.9	104.8	76.9	6.8	
3500			118.1	85.3	10.7	90.2	74.6	8.2			150.6	100.2	9.7	115.0	86.6	7.4	
50°F	2500	10.0	2.2	62.7	53.7	12.5	47.2	47.2	9.4	11	1.6	73.5	58.8	13.4	56.1	51.8	10.2
	3000			66.4	60.8	13.3	52.8	52.8	10.6			78.2	66.7	14.2	62.5	62.5	11.4
	3500			69.6	69.6	13.9	58.0	58.0	11.6			83.1	74.7	15.1	68.5	68.5	12.5
	2500	15.0	4.7	75.1	58.3	10.0	57.4	51.3	7.6	21	5.5	94.2	66.6	9.0	71.9	58.0	6.8
	3000			81.5	66.2	10.9	62.2	58.5	8.3			104.1	76.3	9.9	79.5	66.7	7.6
	3500			86.7	73.7	11.6	63.3	63.3	8.4			113.0	85.7	10.8	86.3	75.2	8.2
2500	22.0	9.8	84.3	61.7	7.7	64.4	54.0	5.9	31	11.5	103.9	70.4	6.7	79.4	61.0	5.1	
3000			93.0	70.5	8.5	71.0	61.9	6.5			116.6	81.2	7.5	89.1	70.6	5.7	
3500			100.4	78.7	9.1	76.7	69.3	7.0			128.0	91.4	8.3	97.7	79.7	6.3	

## HOT WATER HEATING CAPACITIES – 90SHWX

90SHWX4 (4 ROW COIL)					
180°F ENTERING WATER TEMPERATURE					
CFM	GPM	WTR. P.D. FT.	TOTAL MBH	LVG. AIR°F	LVG. WTR°F
2500	10.0	2.2	207.8	147	138
3000			232.4	142	133
3500			255.2	137	129
2500	15.0	4.7	222.4	152	150
3000			251.1	148	146
3500			278.5	144	143
2500	22.0	9.8	232.8	156	159
3000			265.1	152	156
3500			295.7	148	153

\* 70°F return air

**NOTES:**

- 1) See last page for Hot Water Heating Correction Factors.
- 2) Optional 6 row coils should not be used for heating.
- 3) Optional 2 row hot water coils can be factory or field installed.
- 4) When these units are used for hot water heating the leaving air temperature must not exceed 150°F. At high altitude conditions, blower motor may cutout at a lower LAT. Contact factory for information.

90HWK (2 ROW COIL)					
180°F ENTERING WATER TEMPERATURE					
CFM	GPM	WTR. P.D. FT.	TOTAL MBH	LVG. AIR°F	LVG. WTR°F
2500	8.0	1.0	146.2	124	143
3000			160.5	120	140
3500			171.5	115	137
2500	14.0	2.8	162.3	130	157
3000			180.4	126	154
3500			196.2	122	153
2500	21.0	6.1	171.1	133	164
3000			191.2	129	162
3500			209.1	125	160

\* 70°F return air

# SHWX SERIES

DIRECT DRIVE HORIZONTAL 0-10V DC INPUT CONTROLLED UNIT

## CHILLED WATER COOLING CAPACITIES – 120SHWX

120SHWX – CHILLED WATER CAPACITIES																	
ENT. WTR. °F	C.F.M.	120SHWX4 (4 ROW COIL)									120SHWX6 (6 ROW COIL)						
		G. P. M.	WTR. P.D. FT.	80°F DB/67°F WB ENT. AIR			75°F DB/63°F WB ENT. AIR			G. P. M.	WTR. P.D. FT.	80°F DB/67°F WB ENT. AIR			75°F DB/63°F WB ENT. AIR		
				TOTAL MBH	SENS. MBH	TEMP. RISE	TOTAL MBH	SENS. MBH	TEMP. RISE			TOTAL MBH	SENS. MBH	TEMP. RISE	TOTAL MBH	SENS. MBH	TEMP. RISE
42°F	3400	12.0	2.0	104.7	80.0	17.4	79.9	70.3	13.3	15	1.7	130.7	91.5	17.4	99.8	79.6	13.3
	4000			107.3	87.7	17.9	82.0	77.5	13.7			136.7	100.9	18.2	104.4	88.3	13.9
	4600			111.7	95.9	18.6	98.5	98.5	16.4			143.5	110.7	19.1	109.6	97.3	14.6
	3400	21.0	5.8	132.7	90.7	12.6	101.3	78.7	9.7	25	4.7	158.3	102.5	12.7	120.9	88.2	9.7
	4000			142.6	100.9	13.6	108.9	88.0	10.4			172.3	114.8	13.8	131.6	99.2	10.5
	4600			151.4	110.5	14.4	115.7	96.7	11.0			184.8	126.5	14.8	141.2	109.8	11.3
	3400	30.0	11.4	145.5	95.8	9.7	111.1	82.7	7.4	35	9.1	173.2	108.7	9.9	132.3	92.9	7.6
	4000			159.4	107.4	10.6	121.8	93.1	8.1			192.0	122.8	11.0	146.6	105.4	8.4
	4600			171.6	118.2	11.4	131.0	102.8	8.7			208.4	135.9	11.9	159.2	117.1	9.1
45°F	3400	12.0	2.0	96.0	76.8	16.0	73.3	67.8	12.2	15	1.7	119.9	87.4	16.0	91.6	76.4	12.2
	4000			98.5	84.5	16.4	82.5	82.5	13.8			125.4	96.7	16.7	95.8	85.0	12.8
	4600			102.5	92.6	17.1	89.5	89.5	14.9			131.6	106.3	17.5	100.5	93.8	13.4
	3400	21.0	5.8	121.7	86.5	11.6	93.0	75.4	8.9	25	4.7	145.2	97.3	11.6	110.9	84.1	8.9
	4000			130.9	96.4	12.5	100.0	84.4	9.5			158.1	109.2	12.6	120.7	94.8	9.7
	4600			138.9	105.8	13.2	106.1	93.0	10.1			169.6	120.6	13.6	129.5	105.1	10.4
	3400	30.0	11.4	133.5	91.0	8.9	102.0	79.0	6.8	35	9.1	158.9	102.8	9.1	121.3	88.4	6.9
	4000			146.3	102.3	9.8	111.7	89.1	7.4			176.1	116.3	10.1	134.5	100.4	7.7
	4600			157.4	112.8	10.5	120.2	98.5	8.0			191.2	129.0	10.9	146.0	111.7	8.3
50°F	3400	12.0	2.0	81.6	71.6	13.6	62.1	62.1	10.3	15	1.7	101.9	80.6	13.6	77.8	71.0	10.4
	4000			83.7	79.2	13.9	68.8	68.8	11.5			106.6	89.8	14.2	83.6	83.6	11.1
	4600			89.5	89.5	14.9	74.6	74.6	12.4			111.9	99.1	14.9	90.9	90.9	12.1
	3400	21.0	5.8	103.5	79.6	9.9	79.0	70.0	7.5	25	4.7	123.4	88.7	9.9	94.3	77.4	7.5
	4000			111.2	89.1	10.6	85.0	78.7	8.1			134.4	100.1	10.7	102.6	87.6	8.2
	4600			118.1	98.2	11.2	84.3	84.3	8.0			144.1	110.9	11.5	110.1	97.5	8.8
	3400	30.0	11.4	113.5	83.3	7.6	86.7	73.0	5.8	35	9.1	135.1	93.2	7.7	103.1	81.0	5.9
	4000			124.3	94.0	8.3	95.0	82.5	6.3			149.7	105.9	8.6	114.4	92.3	6.5
	4600			133.8	103.9	8.9	102.2	91.5	6.8			162.5	117.9	9.3	124.1	103.0	7.1

## HOT WATER HEATING CAPACITIES – 120SHWX

120SHWX4 (4 ROW COIL)					
180°F ENTERING WATER TEMPERATURE					
CFM	GPM	WTR. P.D. FT.	TOTAL MBH	LVG. AIR°F	LVG. WTR°F
3400	12.0	2.0	273.2	144	135
4000			302.6	140	130
4600			328.3	136	125
3400	21.0	5.8	301.4	152	151
4000			337.0	148	148
4600			370.7	144	145
3400	30.0	11.4	314.4	155	159
4000			352.9	152	156
4600			389.8	148	154

\* 70°F return air

**NOTES:**

- 1) See last page for Hot Water Heating Correction Factors.
- 2) Optional 6 row coils should not be used for heating.
- 3) Optional 2 row hot water coils can be factory or field installed.
- 4) When these units are used for hot water heating the leaving air temperature must not exceed 150°F. At high altitude conditions, blower motor may cutout at a lower LAT. Contact factory for information.

120HWK (2 ROW COIL)					
180°F ENTERING WATER TEMPERATURE					
CFM	GPM	WTR. P.D. FT.	TOTAL MBH	LVG. AIR°F	LVG. WTR°F
3400	11.0	1.0	198.5	124	144
4000			215.8	120	140
4600			229.4	116	138
3400	18.0	2.8	217.8	129	156
4000			239.8	125	153
4600			257.8	122	151
3400	25.0	5.3	227.8	132	162
4000			251.9	128	160
4600			272.0	125	158

\* 70°F return air

---

# SHWX SERIES

## DIRECT DRIVE HORIZONTAL 0-10V DC INPUT CONTROLLED UNIT

### SPECIFICATION GUIDE

Furnish and install First Co. **SHWX/SVWX** Series Blower - Coil units as indicated on the plans.

#### **CABINETS**

Cabinets shall be manufactured of heavy gauge galvanized steel. The entire interior of the cabinet shall be insulated with one inch thick IAQ type insulation. Removable access panels shall be provided on both sides of the cabinet for maintenance and service. All cabinets shall have 2" supply and 1" return flanges.

#### **INSULATION**

The entire interior of the cabinet shall be insulated with one (1) inch insulation. This insulation must meet the requirements of ASTM C 1071, ASTM G 21, ASTM G 22, NFPA 90A, UL-181, and the cleaning practices of NAIMA. Closed Cell, foil faced insulation is available as a option.

#### **MOTOR / BLOWERS**

Blowers shall be resiliently mounted, forward curved blade, and of centrifugal type. Each wheel shall be dynamically balanced for smooth, quiet operation. ECM blowers are direct driven and controled by 0-10V DC. All motors to be field or factory installed and wired at voltage specified by customer.

#### **COILS**

All **SHWX/SVWX** series coils shall consist of aluminum fins mechanically bonded onto 3/8" or 1/2" OD seamless copper tubing. All coils shall be leak tested at 350 PSIG minimum air pressure. Manual air vents shall be standard on all coils. Drain pans shall be coated for corrosion protection.

#### **FILTERS**

One inch throw away filters are standard in 2-5 ton **SHWX/SVWX** units. 1" Merv 11 and 13 are also avaiible. One inch permanent filters are provided as standard in 7-10 ton **SHWX/SVWX** units. Merv 11 and 13 Filters are also available in 1". Filters shall be accessible without tools.

#### **LISTING**

All standard motors are UL Listed. All air handlers shall be rated in accordance with ARI Standard 430.

# SHWX SERIES

DIRECT DRIVE HORIZONTAL 0-10V DC INPUT CONTROLLED UNIT

## HOT WATER HEATING CORRECTION FACTORS

SHWX – HW HEATING CORRECTION FACTORS									
ENTERING AIR TEMP. (°F)	ENTERING WATER TEMPERATURE (°F)								
	100°F	110°F	120°F	130°F	140°F	150°F	160°F	170°F	180°F
50°F	0.455	0.545	0.636	0.727	0.818	0.909	1.000	1.091	1.182
55°F	0.409	0.500	0.591	0.682	0.773	0.864	0.955	1.045	1.136
60°F	0.363	0.455	0.545	0.636	0.727	0.818	0.909	1.000	1.091
65°F	0.318	0.409	0.500	0.591	0.682	0.773	0.864	0.955	1.045
70°F	0.272	0.363	0.455	0.545	0.636	0.727	0.818	0.909	1.000
75°F	0.227	0.318	0.409	0.500	0.591	0.682	0.773	0.864	0.955
80°F	0.182	0.272	0.363	0.455	0.545	0.636	0.727	0.818	0.909

**NOTES:**

1. To determine heating capacity at other than 180°F E.W.T. and 70°F E.A.T. multiply the selected heating capacity at 180°F times the appropriate correction factor from above chart.
2. These correction factors may be used on all First Co. published 180°F heating capacities.
3. When SHWX units are used for hot water heating the leaving air temperature must not exceed 150°F. At high altitude conditions, blower motor may cutout at a lower LAT. Contact factory for information.



SHWX

**WARNING AVERTISSEMENT ADVERTENCIA**  
 Cancer and Reproductive Harm  
 Cancer et Troubles de l'appareil reproducteur  
 Cáncer y Daño Reproductivo  
[www.P65Warnings.ca.gov](http://www.P65Warnings.ca.gov) LBY0057



AMERICAN-MADE. FAMILY OWNED.



FIRST CO.  
P.O. BOX 270969 - DALLAS, TEXAS 75227  
PH. (214) 388-5751 | FAX (214) 388-2255  
WWW.FIRSTCO.COM

JULY 2025