



WHSC Series

Thru-the-wall Condensing Unit

1.0 thru 2.5 Tons



WHSC Series

APPLICATION

The space and cost saving features of through the wall split condensing units continue to be important to architects, engineers, multi-family developers, and today's projects demand higher efficiency equipment.

First Co. is proud to introduce the High Efficiency WHSC Series. The WHSC achieves its efficiency by using the industry's latest state-of-the-art components, such as ECM motors, high efficiency compressors, and enhanced coil technology. In addition, the condensing unit's unique propeller-type fan blade operates at a slower speed and is much quieter than traditional squirrel cage type blowers.

THROUGH-THE-WALL VS CONVENTIONAL CONDENSING UNITS

- Lower Installation Costs - WHSC condensing units install on the same floor as the apartment, townhome, or condominium resulting in considerable first cost savings in refrigerant, refrigerant piping, and electrical wiring compared to condensing units installed on the ground or roof.
- Easier to Service - Being located on the same floor as the apartment, town home, or condominium, service and routine maintenance of the WHSC is much easier and can be performed by one person.
- Through the wall units eliminate theft
- No costly landscaping needed to hide the units
- No condensing unit support pads required
- No additional roof support expenses
- No chaseways to roof or ground needed for refrigerant lines

WHSC Series units are sold and intended for use only with blower coil and air handler units with ECM motors.

Factory Matched Indoor Air Handlers

First Co. offers a complete line of indoor air handlers, factory matched and performance-certified to DOE. An air handler style is available for every application, including closet, recessed wall, and recessed ceiling installations.



WHSC Series

FEATURES:

- High efficiency ECM motor
- Unique cabinet design - unit side panels fit inside rather than outside the base pan to improve water containment on the sides of the cabinet
- High efficiency scroll or reciprocating R-410A compressor
- High pressure switch
- Propeller type fan with ECM motor - Moves more air over the condenser coil at lower operating watts than standard "squirrel cage" type blower
- Lower RPM fan motor - Much quieter operation
- Factory charged with R-410A refrigerant - charge will need to be field adjusted
- Sloped base pan - Positive water drainage from the unit to the building exterior
- Plastic coated coil guard
- Cabinet has a durable, baked-on powder coating

ELECTRICAL DATA 208/230V - 1PH - 60 Hz						
UNIT MODEL	COMPRESSOR		CONDENSER FAN		MIN. CIR. AMPACITY	MAX. OVERCURRENT PROTECTION
	LRA	RLA	FLA	HP		
12WHSC	25	4.7	2.8	1/3	9	15
18WHSC	48	9.0	2.8	1/3	14	20
24WHSC	58.3	12.8	2.8	1/3	19	30
30WHSC	73	14.1	2.8	1/3	21	30

(1) SEER and capacity information are combination ratings certified by First Co. to the U.S. Department of Energy and AHRI. To view (and search) this listing, go to: <http://www.regulations.doe.gov/certification-data/>

or <https://www.ahridirectory.org/>

(2) Contact First Co. for certified coil combinations.

PHYSICAL DIMENSIONS					
UNIT MODEL	H	W	D	LIQ/SUCT. LINE CONN. (SWEAT)	APPROX. SHIP WT.
12WHSC	44	27	23	3/8 O.D. / 5/8 O.D.	235
18WHSC				3/8 O.D. / 3/4 O.D.	255
24WHSC					260
30WHSC					270

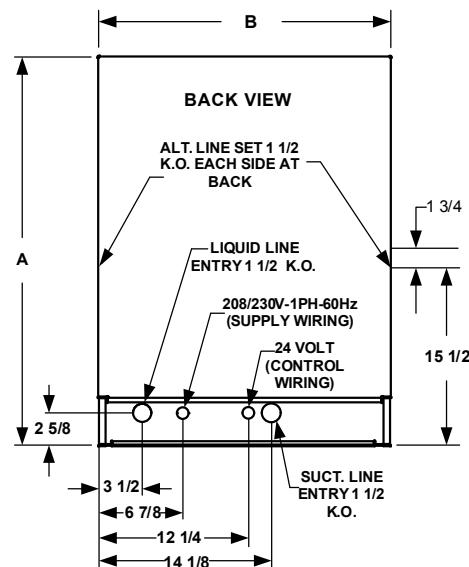
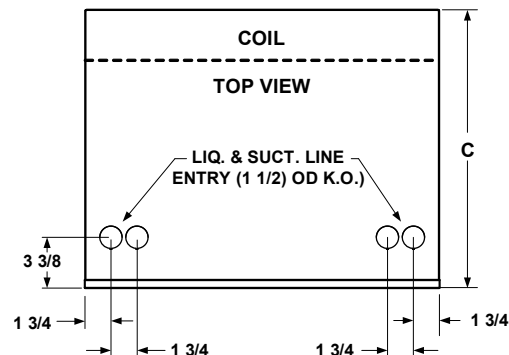

WHSC Series

OPTIONAL ACCESSORIES:

OPTIONAL INSULATION JACKET					
PART NUMBER	USE WITH	DESCRIPTION	DIMENSIONS		
			H	W	D
9WHJ-1	All WHSC models	Insulation jacket	46-1/4	29-1/2	12



Insulation Jacket

OPT. ARCH. GRILLE (FIELD INSTALLED)				
PART (1) NUMBER	USE WITH	DIMENSIONS		
		H	W	D
G212A G212PPA G212S	All WHSC models	44	27	23



Notes:

- "A" = Clear Anodized
"PPA" = Paint Prepared Aluminum
"S" Custom Painted
- Grille screws to the "face" of the condensing unit in place of the factory wire guard.
- Grilles can be factory painted almost any color. Contact the factory for additional information and cost.

OPTIONAL INSTALLATION SLEEVE (See matching grille)					
PART NUMBER	USE WITH	DESCRIPTION	DIMENSIONS		
			H	W	D
9WHS-1	All WHSC models	Sleeve installs in rough-in to facilitate condensing unit installation and removal for service	45-1/2	27-1/2	13



Shown with Insulation Jacket Installed

In keeping with its policy of continuous progress and product improvement, First Co. reserves the right to make changes without notice.



FIRST CO.
P.O. BOX 270969 - DALLAS, TEXAS 75227
PH. (214) 388-5751 | FAX (214) 388-2255
WWW.FIRSTCO.COM

APRIL 2024