



FIRST CO.
P.O. BOX 270969 - DALLAS, TEXAS 75227
PH. (214) 388-5751 | FAX (214) 388-2255
WWW.FIRSTCO.COM

SHWC SERIES

Hydronic
2-20 Tons

- All motors are factory installed
- Sloped and insulated drain pan
- Galvanized steel cabinet
- Insulation meets IAQ standards
- Manual air vents
- Hanger brackets (2 – 5 ton only)
- Adjustable pulleys
- Various motor options
- Factory installed filters



*First Co. commercial - duty **SHWC** chilled or hot water blower coil units are designed for installation within the conditioned area or as remote units with duct systems.*

SHWC SERIES

First Co. commercial - duty **SHWC** chilled or hot water blower coil units are designed for installation within the conditioned area or as remote units with duct systems. Standard 4 row coils can be used for cooling or heating. These air handlers are compact, with large removable panels for installation and ease of service. Separate filter panels are provided on both sides of unit. Optional accessories include 6 row cooling coils, hot water coils, various motor options, mixing boxes, motor starters, and discharge plenums. **All models feature positive slope drain pans.** Standard models are available in 8 popular sizes 800 through 8000 nominal CFM (2 through 20 tons). All standard models are ETL listed and rated in accordance with ARI Standard 430.

CABINET -

Fabricated of heavy gauge galvanized steel. Seismic resistant mounting brackets are standard on 2-5 ton models.

BLOWER -

Resiliently mounted, heavy duty, double inlet, forward curved blade, centrifugal type. Each wheel is dynamically balanced for smooth, quiet operation. All blowers are belt driven with field adjustable pulleys to permit variations in static pressure and air requirements. All blowers have ball bearings.

COILS -

Fabricated of 3/8" or 1/2" OD seamless copper tubes mechanically expanded to highly efficient aluminum fins to maximize heat transfer. All coils have manual air vents. All models have positive slope drain pans.

INSULATION -

The entire interior of the cabinet is insulated with one (1) inch insulation.

FILTER -

One inch throw away filters are provided as standard in all **2 - 5 ton units**. One inch permanent filters are provided as standard in all **7-1/2 - 20 ton units**. **Filters can be changed without tools.** Space available for 2".

FACTORY WIRED -

All standard motors are field or factory installed and wired at voltage specified by customer. (If not specified, multi-voltage motors will be wired at highest voltage)

MOTOR -

Standard motor is 1725 RPM. The adjustable motor mount permits easy belt adjustment. A variable pitch pulley allows balancing of the system to the desired CFM. Standard motors have internal overload protection. Therefore, units shipped with standard motors will be ETL listed. Most non-standard motors (i.e. 575V, 2-speed, TEFC, some 50 Hz., etc.) are not available with internal overload protection. Therefore, most units shipped with non-standard motors can be ETL listed with the addition of a factory installed motor starter (contact the factory for starter information and ETL verification.)

MISCELLANEOUS -

- Slotted mounting rails for easy installation (**2 - 5 ton SHWC** only). Rails are turned down 1/2" on each end for safer and easier installation.
- 4 x 4 junction box accepts a field installed (24/120V) relay / transformer for low voltage control.
- 3/4 inch NPT drain connections on both sides of cabinet.
- Header connections on the right side as standard. Knockouts are provided for conversion to the left side. (Looking with air flow).
- Drain pans are coated for corrosion protection.



SHWC SERIES

Options:

Contact the factory

1. **6 row cooling coil** instead of standard 4 row coil (factory installed only).
2. **Stainless steel** drain pan.
3. **Motor starters.**
4. **Hot water coil** can be field or factory installed in either the reheat or pre-heat position (reheat is standard).

PART NUMBER	FOR UNIT MODEL	MANIFOLD CONNECTIONS
24HWK	24SHWC	7/8" OD
36HWK	36SHWC	
48HWK	48SHWC	
60HWK	60SHWC	
90HWK	90SHWC	1-1/8" OD
120HWK	120SHWC	1-3/8" OD
180HWK	180SHWC	
240HWK	240SHWC	

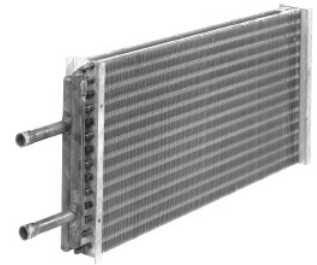

5. **Discharge plenum** with four way double - deflection grille (field installed)

PART NUMBER	FOR UNIT MODEL	DEPTH (1)
24DP	24SHWC	6"
36DP	36SHWC	
48DP	48SHWC	
60DP	60SHWC	
90DP	90SHWC	
120DP	120SHWC	
180DP	180SHWC	
240DP	240SHWC	



(1) Height and width are the same as the unit being attached to.

6. **Relay / Transformer** mounts directly on 4 x 4 junction box on each unit.

Part number is **310-E301** (24/120V), **310-E302** (24.208-230V) and **310-E303** (24/277V)
- (for 2-5 ton models only)

SHWC SERIES

Options (Cont.): Mixing Boxes

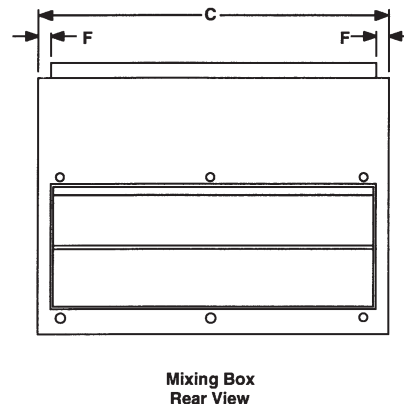
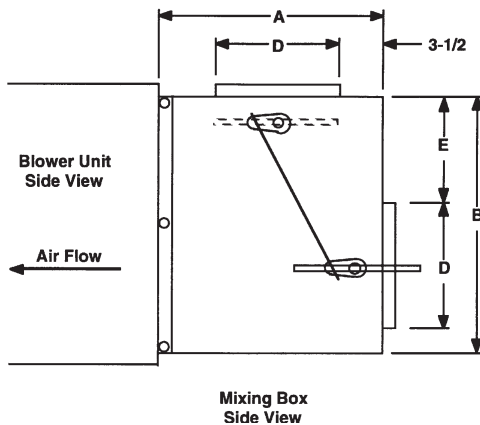

Dimensions:

MODEL	FOR UNIT MODEL	A	B	C	D	E	F	DAMPER SIZE (NOM)	SHIPPING WEIGHT
24MB	24SHWC	16	16-3/8	18-1/8	8	6	1-1/16	2-16 x 8	40
36MB	36SHWC	16	16-3/8	27-5/8	8	6	1-1/16	2-26 x 8	58
48MB	48SHWC	18	20-3/8	29-1/8	10	8	1-1/16	2-27 x 10	65
60MB	60SHWC	18	20-3/8	36-1/8	10	8	1-1/16	2-34 x 10	78
90MB	90SHWC	18	25-3/8	45-1/8	10	8	1-1/16	2-42 x 10	110
120MB	120SHWC	20	30-3/8	48-1/8	12	10	1-1/16	2-46 x 12	135
180MB	180SHWC	22	37-7/8	57-1/8	14	12	1-9/16	2-54 x 14	190
240MB	240SHWC	22	50-1/2	57-1/8	14	24	1-9/16	2-54 x 14	210

Features:

1. Cabinet fully insulated - 3/4 inch.
2. Embossed galvanized cabinet on 24-240MB.
3. Crank arms and linkage rod for damper connection are furnished. Connections can be made on either side of mixing boxes. The balance of necessary linkage hardware, damper motor, and controls to be field supplied.
4. Dampers can be positioned for either rear/top or rear/bottom locations.
5. 1" duct flanges provided on damper openings.
6. Dampers have air seals on the edges for positive closing. 24-90MB have single horizontal damper blades. 120-230MB have double horizontal damper blades.
7. When used with water coil units, a "freezestat" must be installed to prevent coil damage caused by low ambient conditions.

SHWC SERIES

COMPONENT STATIC RESISTANCE

MODEL	NOMINAL CFM	COMPONENT STATIC RESISTANCE (INCHES OF WATER)				
		CABINET	COOLING COIL*		HEATING COIL	FILTER
			4 ROW	6 ROW	2 ROW	
24SHWC	600	0.09	0.14	0.22	0.07	0.04
	700	0.10	0.18	0.27	0.09	0.05
	800	0.11	0.23	0.34	0.12	0.06
	900	0.12	0.28	0.42	0.14	0.07
	1000	0.13	0.33	0.50	0.18	0.08
36SHWC	1000	0.09	0.17	0.25	0.08	0.04
	1100	0.10	0.19	0.28	0.10	0.05
	1200	0.11	0.23	0.34	0.12	0.06
	1300	0.12	0.26	0.39	0.13	0.07
	1400	0.13	0.30	0.45	0.15	0.08
48SHWC	1400	0.09	0.18	0.27	0.09	0.05
	1500	0.10	0.20	0.31	0.10	0.06
	1600	0.11	0.23	0.34	0.11	0.06
	1700	0.12	0.25	0.38	0.12	0.07
	1800	0.13	0.28	0.42	0.13	0.08
60SHWC	1800	0.10	0.20	0.28	0.09	0.05
	1900	0.11	0.21	0.31	0.10	0.06
	2000	0.12	0.23	0.34	0.11	0.06
	2100	0.13	0.25	0.37	0.12	0.07
	2200	0.15	0.28	0.40	0.13	0.08

MODEL	NOMINAL CFM	COMPONENT STATIC RESISTANCE (INCHES OF WATER)				
		CABINET	COOLING COIL*		HEATING COIL	FILTER
			4 ROW	6 ROW	2 ROW	
90SHWC	2500	0.12	0.26	0.39	0.13	0.04
	2750	0.14	0.30	0.45	0.16	0.05
	3000	0.16	0.34	0.51	0.18	0.06
	3250	0.17	0.39	0.58	0.21	0.07
	3500	0.19	0.44	0.65	0.24	0.08
120SHWC	3400	0.14	0.29	0.43	0.14	0.05
	3700	0.15	0.33	0.48	0.16	0.06
	4000	0.17	0.37	0.54	0.19	0.07
	4300	0.19	0.41	0.61	0.21	0.08
	4600	0.21	0.45	0.67	0.24	0.09
180SHWC	5200	0.16	0.30	0.44	0.14	0.05
	5600	0.17	0.33	0.49	0.16	0.06
	6000	0.19	0.37	0.55	0.18	0.07
	6400	0.21	0.41	0.61	0.20	0.08
	6800	0.23	0.45	0.66	0.23	0.09
240SHWC	6000	0.11	0.21	0.31	0.10	0.04
	7000	0.16	0.30	0.44	0.14	0.05
	8000	0.19	0.37	0.55	0.18	0.07
	9000	0.23	0.45	0.66	0.23	0.09
	10000	0.29	0.58	0.86	0.28	0.11

* Wet Coil (Dry Coil P.D. = Wet P.D. x .70)

SHWC SERIES

NOMENCLATURE - Selection Procedure

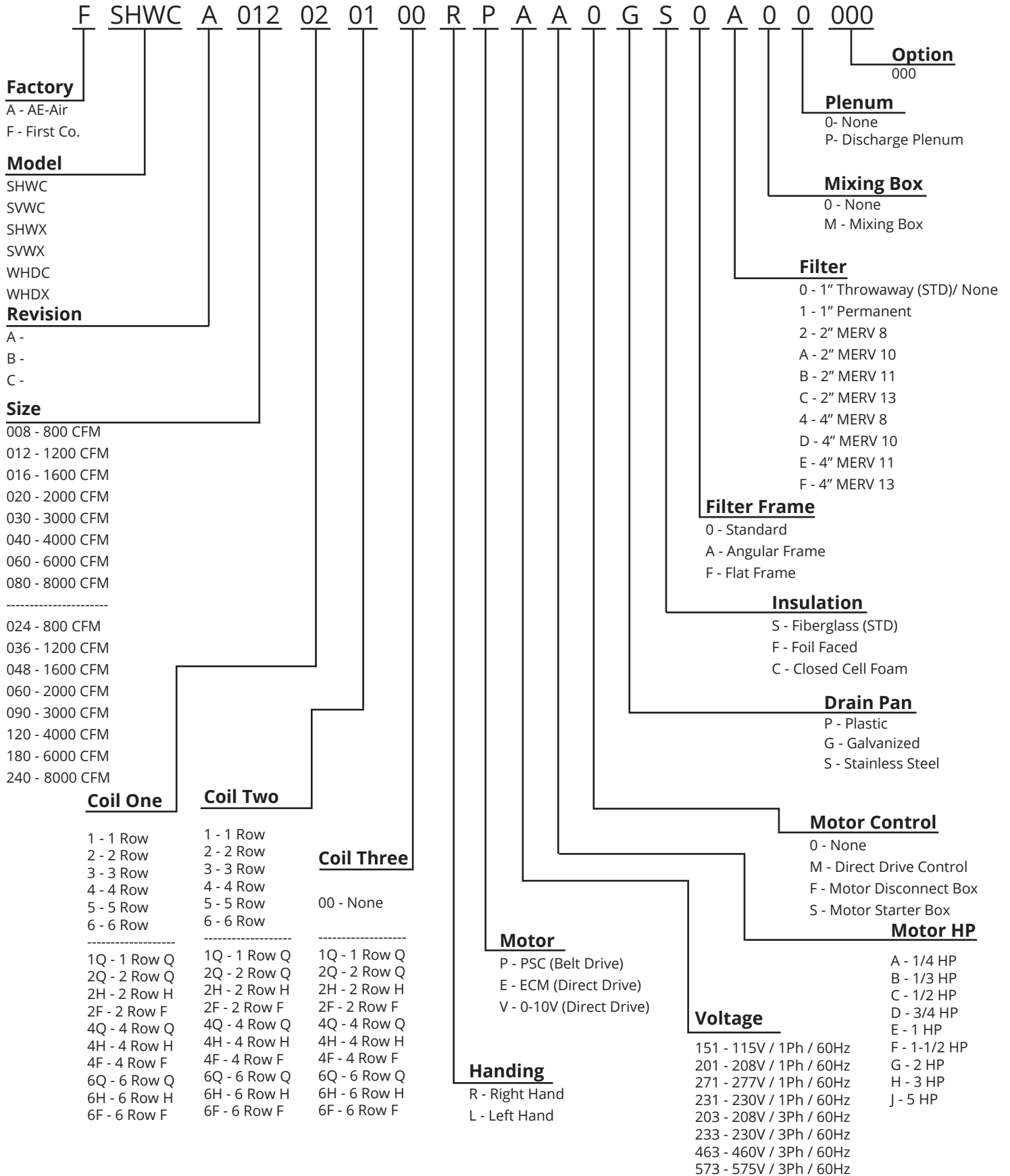

SHWC SERIES

NOMENCLATURE - Selection Procedure

Drive Kit Nomenclature:

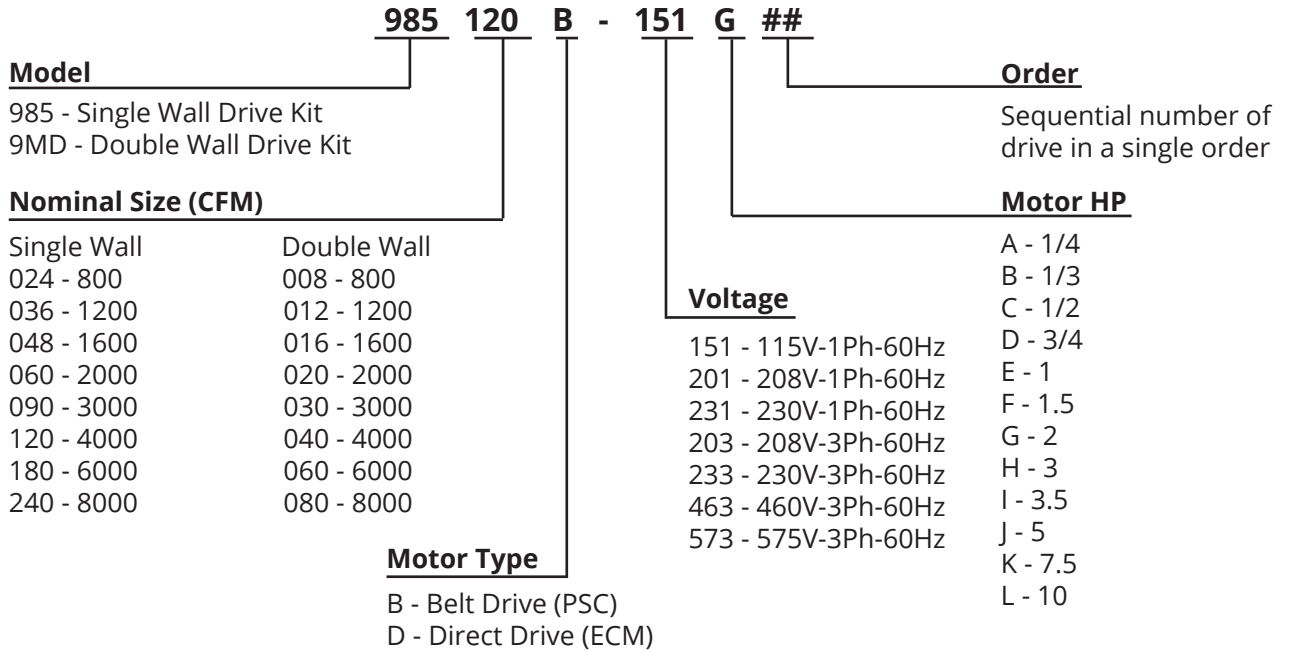

Required Order Information

1. Model number with rows and circuit
2. CFM and external static pressure
3. Motor HP
4. Actual voltage motor is to be wired to
5. Hot water coil installed in preheat or reheat position
6. Hand connections with air hitting you in back of head

Physical Data - Models 24SHWC - 60SHWC

UNIT DIMENSIONS

MODEL	UNIT CABINET				BLOWER OUTLET		RETURN DUCT CONNECTION	
	AA	BB	CC	DD	EE	FF	GG	HH
24SHWC4	37	32-1/2	27	18-7/8	8-3/4	10-7/8	18	16-1/4
36SHWC4	37	42	36-1/2	18-7/8	12-1/4	10-7/8	27-1/2	16-1/4
48SHWC4	39	43-1/2	38	22-7/8	13-5/8	11-7/8	29	20-1/4
60SHWC4	42	50-1/2	45	22-7/8	16	13-7/8	36	20-1/4
24SHWC6	37	32-1/2	27	18-7/8	8-3/4	10-7/8	18	16-1/4
36SHWC6	37	42	36-1/2	18-7/8	12-1/4	10-7/8	27-1/2	16-1/4
48SHWC6	39	43-1/2	38	22-7/8	13-5/8	11-7/8	29	20-1/4
60SHWC6	42	50-1/2	48	22-7/8	16	13-7/8	36	20-1/4

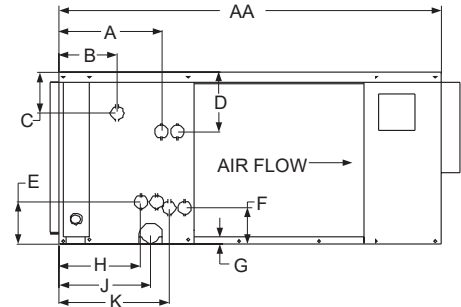

STUBOUT LOCATION FOR WATER COILS

A	B	C	D	E	F	G	H	J	K
11-1/4	6-5/16	4-1/2	6-1/2	4-1/2	3-15/16	1	8-15/16	10	12
11-1/4	6-5/16	4-1/2	6-1/2	4-1/2	3-15/16	1	8-15/16	10	12
11-1/4	6-5/16	3-3/4	5-3/4	4-1/2	3-15/16	1	8-15/16	10	12
11-1/4	6-5/16	3-3/4	5-3/4	4-1/2	3-15/16	1	8-15/16	10	12
12-15/16	6-5/16	4-1/2	6-1/2	4-1/2	3-15/16	1	10-5/8	10	13-3/4
12-15/16	6-5/16	4-1/2	6-1/2	4-1/2	3-15/16	1	10-5/8	10	13-3/4
12-15/16	6-5/16	3-3/4	5-3/4	4-1/2	3-15/16	1	10-5/8	10	13-3/4
12-15/16	6-5/16	3-3/4	5-3/4	4-1/2	3-15/16	1	10-5/8	10	13-3/4

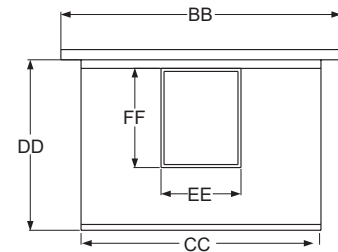

Notes:

- 1) All drain connections are 3/4" MPT and located on same side as coil connections.
- 2) All units have knockouts on both sides for either (standard) or left side coil stub outs. (Looking with airflow) All coil connections must be on the same side of the unit.

GENERAL SPECIFICATIONS

MODEL	NOM. COOL TONS	FACE AREA SQ. FT.	TUBE SIZE	STD. MOTOR HP	VOLTS	PHASE
24SHWC	2	2.05	3/8	1/4	115	1
36SHWC	3	3.05	3/8	1/3	115	1
48SHWC	4	4.0	3/8	1/2	115	1
60SHWC	5	5.0	3/8	1/2	115	1

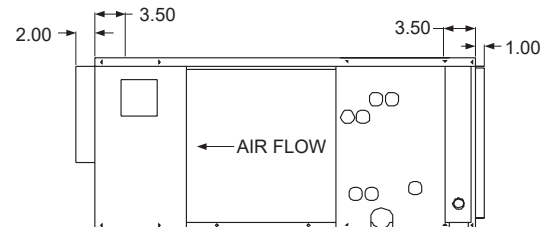

BLOWER SIZE	FILTER SIZE	4 ROW COIL		6 ROW COIL	
		MANIFOLD CONNECTION	SHIPPING WEIGHT	MANIFOLD CONNECTION	SHIPPING WEIGHT
9 X 6	16 X 25	7/8" O/D (SWT)	185	7/8" O/D (SWT)	205
9 X 9	16 X 16 (2)	7/8" O/D (SWT)	205	7/8" O/D (SWT)	225
10 X 10	16 X 20 (2)	7/8" O/D (SWT)	230	7/8" O/D (SWT)	265
12 X 12	20 X 20 (2)	1-1/8" O/D (SWT)	290	1-1/8" O/D (SWT)	310

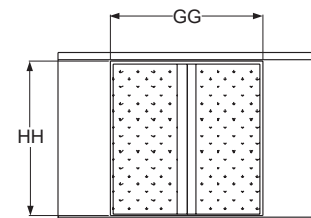

Notes:

- 1) All technical specifications subject to change without notice.
- 2) Additional charge for optional motors.
- 3) When SHWC units are used with hot water coil the leaving air temperature must not exceed 150 degrees. At high altitude conditions, blower motor may cutout air lower LAT. Contact factory for information.
- 4) Contact factory for electric heat information (supplied by others)

Physical Data - Models 90SHWC - 240SHWC

UNIT DIMENSIONS

MODEL	UNIT CABINET			BLOWER OUTLET		RETURN DUCT CONNECTION	
	AA	BB	CC	EE	FF	GG	HH
90SHWC4	52-1/2	54	27	19-1/8	16-3/8	45	25-1/4
120SHWC4	52-1/2	57	32	19-1/8	16-3/8	48	30-1/4
180SHWC4	56-1/2	66	39-1/2	44-3/4	16-3/8	57	37-3/4
240SHWC4	62-1/2	66	52	44-3/4	16-3/8	57	50-1/4
90SHWC6	52-1/2	54	27	19-1/8	16-3/8	45	25-1/4
120SHWC6	52-1/2	57	32	19-1/8	16-3/8	48	30-1/4
180SHWC6	56-1/2	66	39-1/2	44-3/4	16-3/8	57	37-3/4
240SHWC6	62-1/2	66	52	44-3/4	16-3/8	57	50-1/4

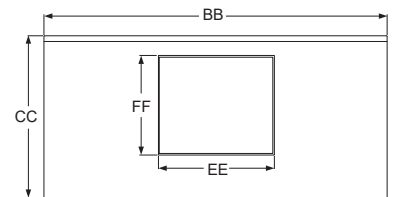
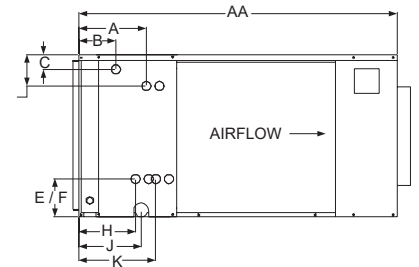

STUBOUT LOCATION FOR WATER COILS										
A	B	C	D	E	F	G	H	J	K	L
11-1/8	6-1/8	2-7/16	5-1/8	6-7/16	6-7/16	1	9-3/8	10-1/4	12-5/8	1
11-1/8	6-1/8	2-7/16	5-1/8	6-7/16	6-7/16	1	9-3/8	10-1/4	12-5/8	6
11-1/8	6-1/8	2-7/16	5-1/8	6-7/16	6-7/16	1	9-3/8	10-1/4	12-5/8	9-5/16
11-1/8	6-1/8	2-7/16	5-1/8	6-7/16	6-7/16	1	9-3/8	10-1/4	12-5/8	21-3/4
13-5/16	6-1/8	2-7/16	5-1/8	6-7/16	6-7/16	1	11-1/2	10-1/4	14-13/16	1
13-5/16	6-1/8	2-7/16	5-1/8	6-7/16	6-7/16	1	11-1/2	10-1/4	14-13/16	6
13-5/16	6-1/8	2-7/16	5-1/8	6-7/16	6-7/16	1	11-1/2	10-1/4	14-13/16	9-5/16
13-5/16	6-1/8	2-7/16	5-1/8	6-7/16	6-7/16	1	11-1/2	10-1/4	14-13/16	21-3/4

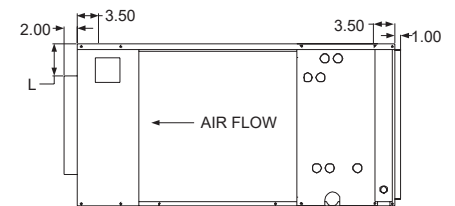

Notes:

- All drain connections are 3/4" MPT and located on same side as coil connections.
- All units have knockouts on both sides for either (standard) or left side coil stub outs.
(Looking with airflow) All coil connections must be on the same side of the unit.
- 180SHWC and 230SHWC models have two blowers. Blower opening size is 16-3/8 X 16-5/8

GENERAL SPECIFICATIONS

MODEL	NOM. COOL TONS	FACE AREA SQ. FT.	TUBE SIZE	STD. MOTOR HP	VOLTS	PHASE	BLOWER SIZE
90SHWC	7-1/2	7.5	1/2	3/4	115/230	1	15 X 15
120SHWC	10	9.6	1/2	1-1/2	230/460	3	15 X 15
180SHWC	15	14.3	1/2	1-1/2	230/460	3	15 X 12 (2)
240SHWC	20	19.1	1/2	3	230/460	3	15 X 12 (2)

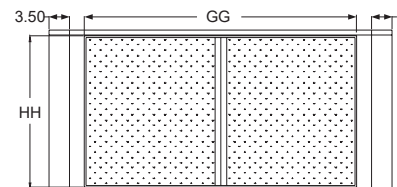

BLOWER SIZE	FILTER SIZE	4 ROW COIL		6 ROW COIL	
		MANIFOLD CONNECTION	SHIPPING WEIGHT	MANIFOLD CONNECTION	SHIPPING WEIGHT
15 X 15	24 X 25 (2)	1-1/8" O/D (SWT)	450	1-1/8" O/D (SWT)	475
15 X 15	26 X 29 (2)	1-3/8" O/D (SWT)	490	1-3/8" O/D (SWT)	535
15 X 12 (2)	20 X 36.5 (3)	1-3/8" O/D (SWT)	670	1-3/8" O/D (SWT)	710
15 X 12 (2)	20 X 49 (3)	1-3/8" O/D (SWT)	835	1-3/8" O/D (SWT)	880

Notes:

- All technical specifications subject to change without notice.
- Additional charge for optional motors.
- When SHWC units are used with hot water coil the leaving air temperature must not exceed 150 degrees.
At high altitude conditions, blower motor may cutout air lower LAT. Contact factory for information.
- Contact factory for electric heat information (supplied by others)

SHWC SERIES

2 - 5 TON FAN PERFORMANCE

MODEL	NOMINAL CFM	COIL FACE VELOCITY FPM	TOTAL STATIC PRESSURE - INCHES OF WATER									
			0.5		0.6		0.7		0.8		0.9	
			RPM	HP	RPM	HP	RPM	HP	RPM	HP	RPM	HP
24SHWC	600	300	770	1/6	840	1/6	900	1/6	990	1/4	1050	1/4
	700	350	780	1/6	850	1/6	910	1/4	990	1/4	1040	1/4
	800	400	800	1/4	860	1/4	910	1/4	990	1/4	1040	1/4
	900	450	810	1/4	880	1/4	925	1/4	1000	1/4	1050	1/3
	1000	500	830	1/4	900	1/4	950	1/3	1000	1/3	1060	1/3
36SHWC	1000	333	805	1/4	880	1/4	940	1/3	1000	1/3	1060	1/3
	1100	367	810	1/4	890	1/3	940	1/3	1000	1/3	1050	1/2
	1200	400	820	1/3	900	1/3	950	1/3	1005	1/2	1050	1/2
	1300	434	840	1/3	905	1/3	960	1/3	1010	1/2	1060	1/2
	1400	466	870	1/3	920	1/3	980	1/2	1020	1/2	1090	1/2
48SHWC	1400	350	720	1/3	775	1/3	825	1/2	870	1/3	910	1/2
	1500	375	740	1/3	785	1/2	830	1/2	875	1/2	920	1/2
	1600	400	750	1/2	800	1/2	840	1/2	890	1/2	925	3/4
	1700	425	770	1/2	810	1/2	860	1/2	895	1/2	930	3/4
	1800	450	785	1/2	825	1/2	870	1/2	910	1/2	945	3/4
60SHWC	1800	360	580	1/2	630	1/2	680	1/2	725	1/2	770	3/4
	1900	380	580	1/2	630	1/2	680	1/2	725	1/2	775	3/4
	2000	400	590	1/2	635	1/2	680	1/2	730	1/2	770	3/4
	2100	420	600	1/2	640	1/2	690	1/2	730	3/4	770	3/4
	2200	440	600	1/2	645	1/2	690	1/2	735	3/4	775	3/4

NOMINAL CFM	COIL FACE VELOCITY FPM	TOTAL STATIC PRESSURE - INCHES OF WATER											
		1.0		1.2		1.4		1.6		1.8		2.0	
		RPM	HP	RPM	HP	RPM	HP	RPM	HP	RPM	HP	RPM	HP
600	300	1105	1/4	1210	1/3	1310	1/3	1420	1/3	1510	1/2	---	---
700	350	1100	1/4	1200	1/3	1300	1/3	1405	1/2	1500	1/2	---	---
800	400	1100	1/3	1195	1/3	1295	1/2	1395	1/2	1470	1/2	---	---
900	450	1100	1/3	1190	1/3	1290	1/2	1390	1/2	1460	1/2	---	---
1000	500	1110	1/3	1200	1/2	1295	1/2	1390	1/2	1450	3/4	---	---
1000	333	1110	1/2	1230	1/2	1335	1/2	1440	3/4	1540	3/4	---	---
1100	367	1110	1/2	1215	1/2	1325	1/2	1425	3/4	1520	3/4	---	---
1200	400	1110	1/2	1210	1/2	1315	3/4	1415	3/4	1500	3/4	---	---
1300	434	1110	1/2	1220	1/2	1315	3/4	1410	3/4	1490	3/4	---	---
1400	466	1120	1/2	1220	3/4	1320	3/4	1410	3/4	1500	3/4	---	---
1400	350	955	1/2	1050	3/4	1135	3/4	1215	3/4	1300	1	1380	1
1500	375	960	1/2	1050	3/4	1135	3/4	1210	3/4	1295	1	1370	1
1600	400	970	3/4	1050	3/4	1140	3/4	1210	3/4	1290	1	1360	1
1700	425	980	3/4	1065	3/4	1140	3/4	1210	3/4	1290	1	1350	1
1800	450	985	3/4	1070	3/4	1150	3/4	1215	1	1280	1	---	---
1800	360	820	3/4	900	3/4	975	3/4	1050	1	1125	1	1200	1-1/2
1900	380	815	3/4	895	3/4	970	3/4	1045	1	1120	1	1190	1-1/2
2000	400	815	3/4	890	3/4	965	1	1040	1	1110	1	1180	1-1/2
2100	420	815	3/4	885	3/4	960	1	1035	1	1105	1-1/2	1175	1-1/2
2200	440	815	3/4	885	3/4	960	1	1030	1	1100	1-1/2	1165	1-1/2

7-1/2 - 20 TON FAN PERFORMANCE

MODEL	NOMINAL CFM	COIL FACE VELOCITY FPM	TOTAL STATIC PRESSURE - INCHES OF WATER									
			0.6		0.7		0.8		0.9		1.0	
			RPM	HP	RPM	HP	RPM	HP	RPM	HP	RPM	HP
90SHWC	2500	333	580	1/2	600	3/4	640	3/4	690	3/4	710	3/4
	2750	366	580	1/2	605	3/4	640	3/4	690	3/4	710	3/4
	3000	400	580	3/4	610	3/4	640	3/4	680	3/4	710	1
	3250	433	590	3/4	630	1	660	1	700	1	715	1
	3500	466	605	1	635	1	670	1	700	1	720	1
120SHWC	3400	354	600	1	630	1	670	1	700	1	730	1-1/2
	3700	385	610	1	650	1	680	1-1/2	705	1-1/2	740	1-1/2
	4000	417	630	1-1/2	670	1-1/2	695	1-1/2	710	1-1/2	750	1-1/2
	4300	448	650	1-1/2	685	1-1/2	705	1-1/2	730	1-1/2	770	2
	4600	480	670	1-1/2	700	2	720	2	760	2	790	2
180SHWC	5200	364	590	1-1/2	620	1-1/2	650	1-1/2	690	1-1/2	710	1-1/2
	5600	391	600	1-1/2	630	1-1/2	670	1-1/2	700	1-1/2	720	2
	6000	420	610	1-1/2	640	1-1/2	680	1-1/2	700	2	730	2
	6400	447	625	2	660	2	690	2	710	2	740	3
	6800	475	640	2	680	2	700	3	720	3	760	3
240SHWC	6000	314	610	1-1/2	640	1-1/2	670	1-1/2	700	2	730	2
	7000	366	640	2	690	2	710	3	740	3	760	3
	8000	419	700	3	720	3	750	3	790	3	800	3
	9000	470	730	5	760	5	800	5	810	5	830	5
	10000	500	800	5	820	5	840	5	880	5	900	5

NOMINAL CFM	COIL FACE VELOCITY FPM	TOTAL STATIC PRESSURE - INCHES OF WATER									
		1.2		1.4		1.6		1.8		2.0	
		RPM	HP	RPM	HP	RPM	HP	RPM	HP	RPM	HP
2500	333	790	3/4	850	1	915	1-1/2	990	1-1/2	1030	1-1/2
2750	366	780	1	840	1	905	1-1/2	980	1-1/2	1020	1-1/2
3000	400	780	1	835	1-1/2	900	1-1/2	970	1-1/2	1010	1-1/2
3250	433	790	1-1/2	840	1-1/2	900	1-1/2	950	1-1/2	1005	2
3500	466	790	1-1/2	845	1-1/2	900	1-1/2	950	2	1005	2
3400	354	790	1-1/2	850	1-1/2	900	1-1/2	950	2	1005	2
3700	385	800	1-1/2	855	1-1/2	905	2	950	2	1005	2
4000	417	805	1-1/2	860	2	910	2	960	2	1005	2
4300	448	820	2	875	2	915	3	970	3	1010	3
4600	480	830	2	890	3	930	3	980	3	1015	3
5200	364	780	2	830	2	900	2	950	3	1000	3
5600	391	790	2	840	2	905	3	950	3	1000	3
6000	420	795	2	850	3	910	3	960	3	1000	3
6400	447	800	3	860	3	915	3	970	3	1000	5
6800	475	810	3	870	3	920	5	975	5	1005	5
6000	314	795	2	850	3	910	3	960	3	1000	3
7000	366	810	3	880	3	920	5	960	5	1000	5
8000	419	850	5	900	5	940	5	990	5	1020	5
9000	470	890	5	920	5	980	5	---	---	---	---
10000	500	---	---	---	---	---	---	---	---	---	---

Notes:

- 1) Shaded area indicates the R.P.M. and C.F.M. range of the standard motor and pulleys.
- 2) To determine available brake horsepower (BHP), take above nominal HP and multiply as follows:
For 1/4 HP to 3/4 HP motors: BHP = nominal X 1.25
For 1 HP to 5 HP motors: BHP = nominal X 1.15
- 3) Special pulleys and motors can be factory furnished at an additional charge.
- 4) Horsepower tabulated indicates minimum recommended motor H.P.
- 5) **Rated in accordance with ARI Standard 430.**

SHWC SERIES

24SHWC CHILLED WATER COOLING CAPACITIES

ENT. WTR. °F	C.F.M.	24SHWC4 (4 ROW COIL)							24SHWC6 (6 ROW COIL)								
		G.P.M.	WTR. P.D. FT.	80°F DB/67°F WB ENT. AIR			75°F DB/63°F WB ENT. AIR			G.P.M.	WTR. P.D. FT.	80°F DB/67°F WB ENT. AIR			75°F DB/63°F WB ENT. AIR		
				TOTAL MBH	SENS. MBH	TEMP. RISE	TOTAL MBH	SENS. MBH	TEMP. RISE			TOTAL MBH	SENS. MBH	TEMP. RISE	TOTAL MBH	SENS. MBH	TEMP. RISE
42	600	3.0	1.2	19.6	13.9	13.0	14.9	12.1	9.9	3.0	1.3	22.3	15.7	14.9	17.0	13.6	11.4
	800			21.7	16.5	14.5	16.6	14.5	11.0			24.9	18.8	16.6	19.0	16.5	12.7
	1000			23.2	18.7	15.5	17.7	16.6	11.8			26.7	21.6	17.8	20.4	19.1	13.6
	600	6.0	4.4	24.8	15.9	8.3	18.9	13.7	6.3	5.0	3.3	26.9	17.5	10.8	20.6	15.0	8.2
	800			29.0	19.2	9.7	22.2	16.7	7.4			31.3	21.2	12.5	24.0	18.4	9.6
	1000			32.5	22.1	10.8	24.8	19.3	8.3			34.9	24.6	13.9	26.6	21.5	10.7
	600	9.0	9.3	26.7	16.6	5.9	20.4	14.3	4.5	7.0	6.1	29.6	18.5	8.4	22.6	15.9	6.4
	800			31.8	20.3	7.1	24.3	17.6	5.4			35.2	22.8	10.0	26.9	19.6	7.7
	1000			36.3	23.6	8.1	27.7	20.4	6.2			39.8	26.5	11.4	30.4	23.0	8.7
45	600	3.0	1.2	17.9	13.3	12.0	13.7	11.6	9.1	3.0	1.3	20.5	14.9	13.7	15.6	13.1	10.4
	800			19.9	15.8	13.3	15.2	14.0	10.1			22.8	18.0	15.2	17.4	15.9	11.6
	1000			21.3	18.1	14.2	17.5	17.5	11.7			24.5	20.8	16.4	21.4	21.4	14.2
	600	6.0	4.4	22.7	15.1	7.6	17.4	13.1	5.8	5.0	3.3	24.7	16.6	9.9	18.9	14.3	7.5
	800			26.6	18.3	8.9	20.3	16.0	6.8			28.7	20.2	11.5	22.0	17.6	8.8
	1000			29.8	21.1	9.9	22.7	18.5	7.6			32.0	23.5	12.8	24.4	20.6	9.8
	600	9.0	9.3	24.5	15.8	5.4	18.7	13.6	4.2	7.0	6.1	27.1	17.5	7.7	20.7	15.1	5.9
	800			29.2	19.3	6.5	22.3	16.8	5.0			32.3	21.6	9.2	24.6	18.7	7.0
	1000			33.3	22.5	7.4	25.4	19.5	5.6			36.5	25.2	10.4	27.9	22.0	8.0
50	600	3.0	1.2	15.2	12.3	10.2	11.6	10.9	7.8	3.0	1.3	17.4	13.8	11.6	13.3	12.2	8.9
	800			16.9	14.8	11.3	12.8	12.8	8.6			19.4	16.8	12.9	15.6	15.6	10.4
	1000			18.1	17.0	12.1	14.6	14.6	9.7			20.9	19.5	13.9	17.8	17.8	11.9
	600	6.0	4.4	19.3	13.8	6.4	14.7	12.0	4.9	5.0	3.3	21.0	15.1	8.4	16.0	13.2	6.4
	800			22.6	16.8	7.5	17.3	14.8	5.8			24.4	18.6	9.8	18.7	16.3	7.5
	1000			25.3	19.5	8.4	19.3	17.2	6.4			27.2	21.7	10.9	20.8	19.2	8.3
	600	9.0	9.3	20.8	14.3	4.6	15.9	12.5	3.5	7.0	6.1	23.1	15.9	6.6	17.6	13.8	5.0
	800			24.8	17.6	5.5	19.0	15.5	4.2			27.4	19.7	7.8	20.9	17.2	6.0
	1000			28.3	20.6	6.3	21.6	18.1	4.8			31.1	23.2	8.9	23.7	20.3	6.8

HOT WATER HEATING CAPACITIES

24SHWC4 (4 ROW COIL)					
180°F ENTERING WATER TEMPERATURE					
CFM	GPM	WTR. P.D. FT.	TOTAL MBH	LVG. AIR °F	LVG. WTR °F
600	3.0	1.2	47.5	143	148
800			56.4	135	142
1000			64.3	130	137
600	6.0	4.4	52.0	150	163
800			63.2	143	159
1000			73.3	138	156
600	9.0	9.3	53.6	153	168
800			65.8	146	165
1000			76.8	141	163

* 70 degree return air

24HWK (2 ROW COIL)					
180°F ENTERING WATER TEMPERATURE					
CFM	GPM	WTR. P.D. FT.	TOTAL MBH	LVG. AIR °F	LVG. WTR °F
600	3.0	0.9	33.3	121	158
800			38.4	115	154
1000			42.9	110	151
600	6.0	3.2	36.6	126	168
800			43.2	120	166
1000			49.0	115	164
600	9.0	6.7	37.9	128	172
800			45.3	122	170
1000			51.8	118	168

* 70 degree return air

- Notes:**
- 1) See page 22 for hot water heating correction factors.
 - 2) Optional 6 row coils should not be used for heating.
 - 3) Optional 2 row hot water coils can be factory or field installed.
 - 4) When these units are used for hot water heating the leaving air temperature must not exceed 150 degrees. At high altitude conditions, blower motor may cutout at a lower LAT. Contact factory for information.

SHWC SERIES

36SHWC

CHILLED WATER COOLING CAPACITIES

ENT. WTR. °F	C.F.M.	36SHWC4 (4 ROW COIL)								36SHWC6 (6 ROW COIL)							
		G.P.M.	WTR. P.D. FT.	80°F DB/67°F WB ENT. AIR			75°F DB/63°F WB ENT. AIR			G.P.M.	WTR. P.D. FT.	80°F DB/67°F WB ENT. AIR			75°F DB/63°F WB ENT. AIR		
				TOTAL MBH	SENS. MBH	TEMP. RISE	TOTAL MBH	SENS. MBH	TEMP. RISE			TOTAL MBH	SENS. MBH	TEMP. RISE	TOTAL MBH	SENS. MBH	TEMP. RISE
42	1000	4.0	2.0	29.6	21.9	14.8	22.6	19.2	11.3	4.0	2.7	35.6	25.4	17.8	27.2	22.1	13.6
	1200			31.4	24.4	15.7	24.0	21.5	12.0			38.0	28.4	19.0	29.1	25.0	14.5
	1400			33.1	26.7	16.6	25.3	23.7	12.7			40.5	31.5	20.2	30.9	27.7	15.5
	1000	8.0	7.5	39.0	25.4	9.8	29.8	22.0	7.4	7.0	7.5	45.0	29.0	12.9	34.4	25.0	9.8
	1200			43.0	28.7	10.7	32.8	24.9	8.2			49.7	33.0	14.2	38.0	28.5	10.8
	1400			46.5	31.6	11.6	35.5	27.6	8.9			53.9	36.6	15.4	41.2	31.8	11.8
600	12.0	16.3	42.6	26.8	7.1	32.5	23.1	5.4	10.0	14.5	49.5	31.0	9.9	37.8	26.5	7.6	
800			47.5	30.4	7.9	36.3	26.3	6.0			55.5	35.3	11.1	42.4	30.3	8.5	
1000			52.0	33.7	8.7	39.7	29.2	6.6			60.9	39.3	12.2	46.5	33.9	9.3	
45	1000	4.0	2.0	27.2	21.0	13.6	21.7	18.5	10.4	4.0	2.7	32.6	24.2	16.3	24.9	21.3	12.5
	1200			28.8	23.4	14.4	22.0	20.7	11.0			34.9	27.3	17.4	26.7	24.0	13.3
	1400			30.4	25.8	15.2	25.0	25.0	12.5			37.1	30.3	18.6	28.4	26.8	14.2
	1000	8.0	7.5	35.8	24.2	8.9	27.3	21.0	6.8	7.0	7.5	41.3	27.6	11.8	31.5	23.9	9.0
	1200			39.4	27.3	9.9	30.1	23.9	7.5			45.6	31.3	13.0	34.8	27.2	10.0
	1400			42.6	30.2	10.7	32.6	26.4	8.1			49.5	34.9	14.1	37.8	30.4	10.8
600	12.0	16.3	39.0	25.5	6.5	29.8	22.0	5.0	10.0	14.5	45.4	29.2	9.1	34.7	25.2	6.9	
800			43.6	28.9	7.3	33.3	25.1	5.5			50.9	33.4	10.2	38.9	28.9	7.8	
1000			47.7	32.1	7.9	36.4	27.9	6.1			55.9	37.3	11.2	42.7	32.3	8.5	
50	1000	4.0	2.0	23.1	19.5	11.5	17.2	17.2	8.6	4.0	2.7	27.7	22.4	13.9	21.2	19.8	10.6
	1200			24.5	21.9	12.2	19.1	19.1	9.5			29.7	25.4	14.8	23.6	23.6	11.8
	1400			25.8	24.2	12.9	20.8	20.8	10.4			31.6	28.3	15.8	26.0	26.0	13.0
	1000	8.0	7.5	30.4	22.2	7.6	23.2	19.4	5.8	7.0	7.5	35.1	25.2	10.0	26.8	22.0	7.7
	1200			33.5	25.1	8.4	25.6	22.1	6.4			38.8	28.7	11.1	29.6	25.2	8.5
	1400			36.2	27.9	9.1	27.7	24.6	6.9			42.1	32.1	12.0	32.1	28.2	9.2
600	12.0	16.3	33.2	23.2	5.5	25.3	20.3	4.2	10.0	14.5	38.6	26.5	7.7	29.5	23.1	5.9	
800			37.1	26.4	6.2	28.3	23.2	4.7			43.3	30.4	8.7	33.0	26.5	6.6	
1000			40.5	29.4	6.8	31.0	25.8	5.2			47.5	34.1	9.5	36.3	29.8	7.3	

HOT WATER HEATING CAPACITIES

36SHWC4 (4 ROW COIL)					
180°F ENTERING WATER TEMPERATURE					
CFM	GPM	WTR. P.D. FT.	TOTAL MBH	LVG. AIR °F	LVG. WTR °F
1000	4.0	2.0	75.5	140	142
1200			83.9	135	138
1400			91.7	131	134
1000	8.0	7.5	83.9	148	159
1200			94.7	143	156
1400			105.1	140	154
1000	12.0	16.3	86.8	150	165
1200			98.9	146	163
1400			110.1	143	162

36HWK (2 ROW COIL)					
180°F ENTERING WATER TEMPERATURE					
CFM	GPM	WTR. P.D. FT.	TOTAL MBH	LVG. AIR °F	LVG. WTR °F
1000	4.0	1.6	53.3	119	153
1200			58.7	115	150
1400			65.4	112	148
1000	8.0	6.1	59.4	125	165
1200			66.2	121	164
1400			72.5	118	162
1000	12.0	13.1	61.5	127	170
1200			68.7	123	168
1400			75.4	120	167

* 70 degree return air

* 70 degree return air

- Notes:**
- 1) See page 22 for hot water heating correction factors.
 - 2) Optional 6 row coils should not be used for heating.
 - 3) Optional 2 row hot water coils can be factory or field installed.
 - 4) When these units are used for hot water heating the leaving air temperature must not exceed 150 degrees. At high altitude conditions, blower motor may cutout at a lower LAT. Contact factory for information.

SHWC SERIES

48SHWC

CHILLED WATER COOLING CAPACITIES

ENT. WTR. °F	C.F.M.	48SHWC4 (4 ROW COIL)									48SHWC6 (6 ROW COIL)								
		G.P.M.	WTR. P.D. FT.	80°F DB/67°F WB ENT. AIR			75°F DB/63°F WB ENT. AIR			G.P.M.	WTR. P.D. FT.	80°F DB/67°F WB ENT. AIR			75°F DB/63°F WB ENT. AIR				
				TOTAL MBH	SENS. MBH	TEMP. RISE	TOTAL MBH	SENS. MBH	TEMP. RISE			TOTAL MBH	SENS. MBH	TEMP. RISE	TOTAL MBH	SENS. MBH	TEMP. RISE		
42	1400	6.0	3.9	42.9	31.0	14.3	32.8	27.2	10.9	5.0	2.3	45.6	33.8	18.2	34.8	29.6	13.9		
	1600			45.1	33.6	15.0	34.5	29.6	11.5			47.5	36.7	19.0	36.3	32.3	14.5		
	1800			46.5	35.9	15.5	35.5	31.6	11.8			48.7	39.3	19.5	37.2	34.7	14.9		
	1400	10.0	10.3	52.6	34.7	10.5	40.2	30.1	8.0	8.0	5.5	57.0	38.2	14.2	43.5	33.1	10.9		
	1600			56.4	37.9	11.3	43.1	32.9	8.6			60.7	41.7	15.2	46.3	36.2	11.6		
	1800			59.7	40.7	11.9	45.6	35.5	9.1			63.7	44.9	15.9	48.7	39.2	12.2		
	1400	13.0	17.0	56.3	36.1	8.7	43.0	31.2	6.6	11.0	10.1	63.6	40.9	11.6	48.6	35.2	8.8		
	1600			60.8	39.6	9.4	46.5	34.3	7.1			68.6	44.8	12.5	52.4	38.7	9.5		
	1800			65.0	42.8	10.0	49.6	37.1	7.6			73.1	48.5	13.3	55.8	42.0	10.1		
45	1400	6.0	3.9	39.4	29.7	13.1	30.1	26.1	10.0	5.0	2.3	41.8	32.4	16.7	31.9	28.5	12.8		
	1600			41.4	32.3	13.8	31.6	28.5	10.5			43.6	35.3	17.4	33.3	31.2	13.3		
	1800			42.6	34.5	14.2	32.6	30.5	10.9			44.7	37.8	17.9	39.6	39.6	15.8		
	1400	10.0	10.3	48.3	33.0	9.7	36.9	28.8	7.4	8.0	5.5	52.3	36.4	13.1	39.9	31.7	10.0		
	1600			51.8	26.1	10.4	39.5	31.5	7.9			55.7	39.8	13.9	42.5	34.7	10.6		
	1800			54.7	38.9	10.9	41.8	34.1	8.4			58.4	42.9	14.6	44.6	37.6	11.2		
	1400	13.0	17.0	51.6	34.3	7.9	39.4	29.8	6.1	11.0	10.1	58.4	38.8	10.6	44.6	33.5	8.1		
	1600			55.8	37.6	8.6	42.6	32.7	6.6			63.0	42.6	11.4	48.1	36.9	8.7		
	1800			59.6	40.7	9.2	45.5	35.5	7.0			67.0	46.2	12.2	51.2	40.2	9.3		
50	1400	6.0	3.9	33.5	27.6	11.2	24.2	24.2	8.1	5.0	2.3	35.5	30.2	14.2	28.4	28.4	11.4		
	1600			35.2	30.1	11.7	26.1	26.1	8.7			37.1	32.9	14.6	30.7	30.7	12.3		
	1800			36.2	32.2	12.1	28.0	28.0	9.3			38.0	35.5	15.2	33.0	33.0	13.2		
	1400	10.0	10.3	41.0	30.3	8.2	31.3	26.6	6.3	8.0	5.5	44.4	33.4	11.1	33.9	29.3	8.5		
	1600			44.0	33.2	8.8	33.6	29.3	6.7			47.3	36.6	11.8	36.1	32.3	9.0		
	1800			46.5	35.9	9.3	35.5	31.7	7.1			49.7	39.7	12.4	37.9	35.0	9.5		
	1400	13.0	17.0	43.9	31.4	6.8	33.5	27.5	5.2	11.0	10.1	49.6	35.4	9.0	37.9	30.9	6.9		
	1600			47.4	34.5	7.3	36.2	30.3	5.6			53.5	39.0	11.8	40.9	34.1	7.4		
	1800			50.7	37.4	7.8	38.7	32.9	6.0			57.0	42.4	10.4	43.5	37.2	7.9		

HOT WATER HEATING CAPACITIES

48SHWC4 (4 ROW COIL)					
180°F ENTERING WATER TEMPERATURE					
CFM	GPM	WTR. P.D. FT.	TOTAL MBH	LVG. AIR °F	LVG. WTR °F
1400	6.0	3.9	106.3	140	145
1600			114.9	137	142
1800			123.3	133	139
1400	10.0	10.3	114.9	146	157
1600			125.3	143	155
1800			135.3	140	153
1400	13.0	17.0	118.0	148	162
1600			129.4	145	160
1800			140.0	142	158

48HWK (2 ROW COIL)					
180°F ENTERING WATER TEMPERATURE					
CFM	GPM	WTR. P.D. FT.	TOTAL MBH	LVG. AIR °F	LVG. WTR °F
1400	5.0	2.0	72.8	118	151
1600			78.0	115	149
1800			82.7	113	147
1400	8.0	4.8	79.2	122	160
1600			85.4	119	159
1800			91.4	117	157
1400	12.0	10.4	83.3	125	166
1600			90.2	122	165
1800			97.0	120	164

* 70 degree return air

* 70 degree return air

- Notes:**
- 1) See page 22 for hot water heating correction factors.
 - 2) Optional 6 row coils should not be used for heating.
 - 3) Optional 2 row hot water coils can be factory or field installed.
 - 4) When these units are used for hot water heating the leaving air temperature must not exceed 150 degrees. At high altitude conditions, blower motor may cutout at a lower LAT. Contact factory for information.

SHWC SERIES

60SHWC CHILLED WATER COOLING CAPACITIES

ENT. WTR. °F	C.F.M.	60SHWC4 (4 ROW COIL)									60SHWC6 (6 ROW COIL)						
		G.P.M.	WTR. P.D. FT.	80°F DB/67°F WB ENT. AIR			75°F DB/63°F WB ENT. AIR			G.P.M.	WTR. P.D. FT.	80°F DB/67°F WB ENT. AIR			75°F DB/63°F WB ENT. AIR		
				TOTAL MBH	SENS. MBH	TEMP. RISE	TOTAL MBH	SENS. MBH	TEMP. RISE			TOTAL MBH	SENS. MBH	TEMP. RISE	TOTAL MBH	SENS. MBH	TEMP. RISE
42	1800	6.0	1.8	48.7	37.4	16.2	37.2	33.0	12.4	6.0	1.6	57.5	43.0	19.2	43.9	37.7	14.6
	2000			49.0	39.3	16.3	37.4	34.8	12.5			57.8	45.3	19.3	44.2	39.9	14.7
	2200			49.6	41.3	16.5	43.1	43.1	14.4			58.8	47.8	19.6	44.9	42.3	15.0
	1800	11.0	5.7	63.6	43.0	11.6	48.6	37.4	8.8	9.0	3.4	69.6	47.6	15.5	53.2	41.4	11.8
	2000			66.7	45.9	12.1	50.9	40.0	9.3			72.1	50.7	16.0	55.1	44.2	12.2
	2200			69.4	48.5	12.6	53.0	42.4	9.6			74.6	53.7	16.6	57.0	46.9	12.7
	1800	16.0	11.6	70.6	45.7	8.8	53.9	39.5	6.7	12.0	5.9	77.3	50.7	12.9	59.1	43.8	9.8
	2000			75.3	49.1	9.4	57.5	42.6	7.2			81.5	54.3	13.6	62.3	47.0	10.4
	2200			79.4	52.3	9.9	60.6	45.4	7.6			85.4	57.8	14.2	65.2	50.2	10.9
45	1800	6.0	1.8	44.7	35.9	14.9	34.1	31.8	11.4	6.0	1.6	52.7	41.2	17.6	40.3	36.3	13.4
	2000			45.0	37.9	15.0	37.1	37.8	12.4			53.1	43.6	17.7	40.5	38.5	13.5
	2200			45.5	39.9	15.2	39.2	39.2	13.1			53.9	46.0	18.0	48.3	48.3	16.1
	1800	11.0	5.7	58.4	41.0	10.6	44.6	35.8	8.1	9.0	3.4	63.8	45.4	14.2	48.8	39.6	10.8
	2000			61.2	43.8	11.1	46.7	38.4	8.5			66.2	48.4	14.7	50.5	42.4	11.2
	2200			63.7	46.4	11.6	48.6	40.7	8.8			68.5	51.4	15.2	52.3	45.1	11.6
	1800	16.0	11.6	64.8	43.4	8.1	49.5	37.7	6.2	12.0	5.9	71.0	48.2	11.8	54.2	41.8	9.0
	2000			69.1	46.7	8.6	52.7	40.7	6.6			74.8	51.7	12.5	57.1	45.0	9.5
	2200			72.9	49.8	9.1	55.6	43.5	7.0			78.3	55.1	13.1	59.8	48.0	10.0
50	1800	6.0	1.8	38.0	33.6	12.7	29.1	29.1	9.7	6.0	1.6	44.8	38.3	14.9	35.5	35.5	11.8
	2000			38.2	35.5	12.7	31.0	31.0	10.3			45.1	40.7	15.0	38.0	38.0	12.7
	2200			39.2	39.2	13.1	32.7	32.7	10.9			45.8	43.2	15.3	40.2	40.2	13.4
	1800	11.0	5.7	49.6	37.7	9.0	37.9	33.2	6.9	9.0	3.4	54.3	41.8	12.1	41.4	36.8	9.2
	2000			52.0	40.4	9.5	39.7	35.7	7.2			56.2	44.7	12.5	43.0	39.5	9.5
	2200			54.1	42.9	9.8	41.3	38.0	7.5			58.2	47.6	12.9	44.5	42.1	9.9
	1800	16.0	11.6	55.1	39.7	6.9	42.1	34.8	5.3	12.0	5.9	60.3	44.1	10.1	46.1	38.6	7.7
	2000			58.7	42.9	7.3	44.8	37.6	5.6			63.6	47.4	10.6	48.6	41.6	8.1
	2200			61.9	45.8	7.7	47.3	40.2	5.9			66.6	50.7	11.1	50.9	44.5	8.5

HOT WATER HEATING CAPACITIES

60SHWC4 (4 ROW COIL)					
180°F ENTERING WATER TEMPERATURE					
CFM	GPM	WTR. P.D. FT.	TOTAL MBH	LVG. AIR °F	LVG. WTR °F
1800	6.0	1.8	128.0	136	137
2000			136.2	133	135
2200			143.8	131	132
1800	11.0	5.7	142.6	143	154
2000			152.9	141	152
2200			162.6	138	150
1800	16.0	11.6	149.6	147	161
2000			160.8	144	160
2200			171.4	142	159

60HWK (2 ROW COIL)					
180°F ENTERING WATER TEMPERATURE					
CFM	GPM	WTR. P.D. FT.	TOTAL MBH	LVG. AIR °F	LVG. WTR °F
1800	6.0	3.1	93.1	118	149
2000			98.2	116	147
2200			103.1	113	145
1800	9.0	6.6	100.4	122	158
2000			106.5	119	156
2200			112.6	117	155
1800	12.0	11.5	104.4	124	163
2000			111.0	121	162
2200			117.7	120	160

* 70 degree return air

* 70 degree return air

- Notes:**
- 1) See page 22 for hot water heating correction factors.
 - 2) Optional 6 row coils should not be used for heating.
 - 3) Optional 2 row hot water coils can be factory or field installed.
 - 4) When these units are used for hot water heating the leaving air temperature must not exceed 150 degrees. At high altitude conditions, blower motor may cutout at a lower LAT. Contact factory for information.

SHWC SERIES

90SHWC CHILLED WATER COOLING CAPACITIES

ENT. WTR. °F	C.F.M.	90SHWC4 (4 ROW COIL)									90SHWC6 (6 ROW COIL)								
		G.P.M.	WTR. P.D. FT.	80°F DB/67°F WB ENT. AIR			75°F DB/63°F WB ENT. AIR			G.P.M.	WTR. P.D. FT.	80°F DB/67°F WB ENT. AIR			75°F DB/63°F WB ENT. AIR				
				TOTAL MBH	SENS. MBH	TEMP. RISE	TOTAL MBH	SENS. MBH	TEMP. RISE			TOTAL MBH	SENS. MBH	TEMP. RISE	TOTAL MBH	SENS. MBH	TEMP. RISE		
42	2500	10.0	2.2	80.4	60.2	16.1	61.4	52.8	12.3	11	1.6	94.2	66.6	17.1	71.9	58.0	13.1		
	3000			85.2	67.6	17.0	65.0	59.6	13.0			100.3	74.9	18.2	76.6	65.6	13.9		
	3500			89.4	74.7	17.9	76.5	76.5	15.3			106.6	83.3	19.4	81.4	73.3	14.8		
	2500	15.0	4.7	96.3	66.3	12.8	73.5	57.6	9.8	21	5.5	120.7	77.2	11.5	92.2	66.3	8.8		
	3000			104.5	74.8	13.9	79.8	65.3	10.6			133.4	87.8	12.7	101.9	75.8	9.7		
	3500			111.2	82.7	14.8	84.9	72.5	11.3			144.9	98.0	13.8	110.1	84.8	10.5		
	2500	22.0	9.8	108.1	71.0	9.8	82.6	61.3	7.5	31	11.5	133.3	82.4	8.6	101.8	70.3	6.6		
	3000			119.3	80.6	10.8	91.1	69.8	8.3			149.6	94.4	9.6	114.2	80.9	7.4		
	3500			128.8	89.4	11.7	98.3	77.8	8.9			164.1	105.7	10.6	125.3	90.9	8.1		
45	2500	10.0	2.2	73.8	57.8	14.8	56.3	50.9	11.3	11	1.6	86.4	63.6	15.7	66.0	55.7	12.0		
	3000			78.1	65.0	15.6	63.4	63.4	12.7			92.0	71.8	16.7	70.3	63.2	12.8		
	3500			82.0	72.0	16.4	69.6	69.6	13.9			97.8	80.0	17.8	74.7	70.7	13.6		
	2500	15.0	4.7	88.3	63.3	11.8	67.5	55.2	9.0	21	5.5	110.8	73.2	10.6	84.6	63.1	8.1		
	3000			95.8	71.6	12.8	73.2	62.8	9.8			122.4	83.4	11.7	93.5	72.3	8.9		
	3500			102.0	79.3	13.6	77.9	69.8	10.4			132.9	93.3	12.7	101.5	81.2	9.7		
	2500	22.0	9.8	99.2	67.5	9.0	75.8	58.5	6.9	31	11.5	122.3	77.8	7.9	93.4	66.7	6.0		
	3000			109.4	76.7	9.9	83.6	66.8	7.6			137.2	89.4	8.9	104.8	76.9	6.8		
	3500			118.1	85.3	10.7	90.2	74.6	8.2			150.6	100.2	9.7	115.0	86.6	7.4		
50	2500	10.0	2.2	62.7	53.7	12.5	47.2	47.2	9.4	11	1.6	73.5	58.8	13.4	56.1	51.8	10.2		
	3000			66.4	60.8	13.3	52.8	52.8	10.6			78.2	66.7	14.2	62.5	62.5	11.4		
	3500			69.6	69.6	13.9	58.0	58.0	11.6			83.1	74.7	15.1	68.5	68.5	12.5		
	2500	15.0	4.7	75.1	58.3	10.0	57.4	51.3	7.6	21	5.5	94.2	66.6	9.0	71.9	58.0	6.8		
	3000			81.5	66.2	10.9	62.2	58.5	8.3			104.1	76.3	9.9	79.5	66.7	7.6		
	3500			86.7	73.7	11.6	63.3	63.3	8.4			113.0	85.7	10.8	86.3	75.2	8.2		
	2500	22.0	9.8	84.3	61.7	7.7	64.4	54.0	5.9	31	11.5	103.9	70.4	6.7	79.4	61.0	5.1		
	3000			93.0	70.5	8.5	71.0	61.9	6.5			116.6	81.2	7.5	89.1	70.6	5.7		
	3500			100.4	78.7	9.1	76.7	69.3	7.0			128.0	91.4	8.3	97.7	79.7	6.3		

HOT WATER HEATING CAPACITIES

90SHWC4 (4 ROW COIL)					
180°F ENTERING WATER TEMPERATURE					
CFM	GPM	WTR. P.D. FT.	TOTAL MBH	LVG. AIR °F	LVG. WTR °F
2500	10.0	2.2	207.8	147	138
3000			232.4	142	133
3500			255.2	137	129
2500	15.0	4.7	222.4	152	150
3000			251.1	148	146
3500			278.5	144	143
2500	22.0	9.8	232.8	156	159
3000			265.1	152	156
3500			295.7	148	153

* 70 degree return air

90HWK (2 ROW COIL)					
180°F ENTERING WATER TEMPERATURE					
CFM	GPM	WTR. P.D. FT.	TOTAL MBH	LVG. AIR °F	LVG. WTR °F
2500	8.0	1.0	146.2	124	143
3000			160.5	120	140
3500			171.5	115	137
2500	14.0	2.8	162.3	130	157
3000			180.4	126	154
3500			196.2	122	153
2500	21.0	6.1	171.1	133	164
3000			191.2	129	162
3500			209.1	125	160

* 70 degree return air

- Notes:**
- 1) See page 22 for hot water heating correction factors.
 - 2) Optional 6 row coils should not be used for heating.
 - 3) Optional 2 row hot water coil can be factory installed in either the reheat (std.) or preheat positions.
 - 4) When these units are used with hot water coil the leaving air temperature must not exceed 150 degrees. At high altitude conditions, blower motor may cutout at a lower LAT. Contact factory for information.

SHWC SERIES

120SHWC

CHILLED WATER COOLING CAPACITIES

ENT. WTR. °F	C.F.M.	120SHWC4 (4 ROW COIL)								120SHWC6 (6 ROW COIL)									
		G.P.M.	WTR. P.D. FT.	80°F DB/67°F WB ENT. AIR			75°F DB/63°F WB ENT. AIR			G.P.M.	WTR. P.D. FT.	80°F DB/67°F WB ENT. AIR			75°F DB/63°F WB ENT. AIR				
				TOTAL MBH	SENS. MBH	TEMP. RISE	TOTAL MBH	SENS. MBH	TEMP. RISE			TOTAL MBH	SENS. MBH	TEMP. RISE	TOTAL MBH	SENS. MBH	TEMP. RISE		
42	3400	12.0	2.0	104.7	80.0	17.4	79.9	70.3	13.3	15	1.7	130.7	91.5	17.4	99.8	79.6	13.3		
	4000			107.3	87.7	17.9	82.0	77.5	13.7			136.7	100.9	18.2	104.4	88.3	13.9		
	4600			111.7	95.9	18.6	98.5	98.5	16.4			143.5	110.7	19.1	109.6	97.3	14.6		
	45	3400	21.0	5.8	132.7	90.7	12.6	101.3	78.7	9.7	25	4.7	158.3	102.5	12.7	120.9	88.2	9.7	
		4000			142.6	100.9	13.6	108.9	88.0	10.4			172.3	114.8	13.8	131.6	99.2	10.5	
		4600			151.4	110.5	14.4	115.7	96.7	11.0			184.8	126.5	14.8	141.2	109.8	11.3	
		50	3400	30.0	11.4	145.5	95.8	9.7	111.1	82.7	7.4	35	9.1	173.2	108.7	9.9	132.3	92.9	7.6
			4000			159.4	107.4	10.6	121.8	93.1	8.1			192.0	122.8	11.0	146.6	105.4	8.4
			4600			171.6	118.2	11.4	131.0	102.8	8.7			208.4	135.9	11.9	159.2	117.1	9.1
42			3400	12.0	2.0	96.0	76.8	16.0	73.3	67.8	12.2	15	1.7	119.9	87.4	16.0	91.6	76.4	12.2
			4000			98.5	84.5	16.4	82.5	82.5	13.8			125.4	96.7	16.7	95.8	85.0	12.8
			4600			102.5	92.6	17.1	89.5	89.5	14.9			131.6	106.3	17.5	100.5	93.8	13.4
	45		3400	21.0	5.8	121.7	86.5	11.6	93.0	75.4	8.9	25	4.7	145.2	97.3	11.6	110.9	84.1	8.9
			4000			130.9	96.4	12.5	100.0	84.4	9.5			158.1	109.2	12.6	120.7	94.8	9.7
			4600			138.9	105.8	13.2	106.1	93.0	10.1			169.6	120.6	13.6	129.5	105.1	10.4
		50	3400	30.0	11.4	133.5	91.0	8.9	102.0	79.0	6.8	35	9.1	158.9	102.8	9.1	121.3	88.4	6.9
			4000			146.3	102.3	9.8	111.7	89.1	7.4			176.1	116.3	10.1	134.5	100.4	7.7
			4600			157.4	112.8	10.5	120.2	98.5	8.0			191.2	129.0	10.9	146.0	111.7	8.3
42			3400	12.0	2.0	81.6	71.6	13.6	62.1	62.1	10.3	15	1.7	101.9	80.6	13.6	77.8	71.0	10.4
			4000			83.7	79.2	13.9	68.8	68.8	11.5			106.6	89.8	14.2	83.6	83.6	11.1
			4600			89.5	89.5	14.9	74.6	74.6	12.4			111.9	99.1	14.9	90.9	90.9	12.1
	45		3400	21.0	5.8	103.5	79.6	9.9	79.0	70.0	7.5	25	4.7	123.4	88.7	9.9	94.3	77.4	7.5
			4000			111.2	89.1	10.6	85.0	78.7	8.1			134.4	100.1	10.7	102.6	87.6	8.2
			4600			118.1	98.2	11.2	84.3	84.3	8.0			144.1	110.9	11.5	110.1	97.5	8.8
		50	3400	30.0	11.4	113.5	83.3	7.6	86.7	73.0	5.8	35	9.1	135.1	93.2	7.7	103.1	81.0	5.9
			4000			124.3	94.0	8.3	95.0	82.5	6.3			149.7	105.9	8.6	114.4	92.3	6.5
			4600			133.8	103.9	8.9	102.2	91.5	6.8			162.5	117.9	9.3	124.1	103.0	7.1

HOT WATER HEATING CAPACITIES

120SHWC4 (4 ROW COIL)					
180°F ENTERING WATER TEMPERATURE					
CFM	GPM	WTR. P.D. FT.	TOTAL MBH	LVG. AIR °F	LVG. WTR °F
3400	12.0	2.0	273.2	144	135
4000			302.6	140	130
4600			328.3	136	125
3400	21.0	5.8	301.4	152	151
4000			337.0	148	148
4600			370.7	144	145
3400	30.0	11.4	314.4	155	159
4000			352.9	152	156
4600			389.8	148	154

120HWK (2 ROW COIL)					
180°F ENTERING WATER TEMPERATURE					
CFM	GPM	WTR. P.D. FT.	TOTAL MBH	LVG. AIR °F	LVG. WTR °F
3400	11.0	1.0	198.5	124	144
4000			215.8	120	140
4600			229.4	116	138
3400	18.0	2.8	217.8	129	156
4000			239.8	125	153
4600			257.8	122	151
3400	25.0	5.3	227.8	132	162
4000			251.9	128	160
4600			272.0	125	158

* 70 degree return air

* 70 degree return air

- Notes:**
- 1) See page 22 for hot water heating correction factors.
 - 2) Optional 6 row coils should not be used for heating.
 - 3) Optional 2 row hot water coil can be factory installed in either the reheat (std.) or preheat positions.
 - 4) When these units are used with hot water coil the leaving air temperature must not exceed 150 degrees. At high altitude conditions, blower motor may cutout at a lower LAT. Contact factory for information.

SHWC SERIES

180SHWC CHILLED WATER COOLING CAPACITIES

ENT. WTR. °F	C.F.M.	180SHWC4 (4 ROW COIL)							180SHWC6 (6 ROW COIL)								
		G.P.M.	WTR. P.D. FT.	80°F DB/67°F WB ENT. AIR			75°F DB/63°F WB ENT. AIR			G.P.M.	WTR. P.D. FT.	80°F DB/67°F WB ENT. AIR			75°F DB/63°F WB ENT. AIR		
				TOTAL MBH	SENS. MBH	TEMP. RISE	TOTAL MBH	SENS. MBH	TEMP. RISE			TOTAL MBH	SENS. MBH	TEMP. RISE	TOTAL MBH	SENS. MBH	TEMP. RISE
42	5200	18.0	2.0	155.0	120.4	17.2	118.4	105.9	13.2	20	1.7	184.0	133.8	18.4	140.5	116.9	14.1
	6000			157.4	130.2	17.5	134.8	134.8	15.0			188.1	145.0	18.8	143.6	127.4	14.4
	6800			164.0	141.4	18.2	145.0	145.0	16.1			197.4	158.2	19.7	150.8	139.5	15.1
	5200	30.0	5.3	194.3	135.3	13.0	148.4	117.7	9.9	30	3.6	218.3	147.2	14.6	166.8	127.4	11.1
	6000			205.7	148.2	13.7	157.1	129.5	10.5			230.7	161.3	15.4	176.2	140.3	11.7
	6800			216.6	160.7	14.4	165.4	140.9	11.0			244.4	175.8	16.3	186.6	153.5	12.4
	5200	42.0	10.1	214.9	143.3	10.2	164.1	124.0	7.8	40	6.3	230.6	156.2	12.0	183.8	134.4	9.2
	6000			231.9	158.2	11.0	177.1	137.4	8.4			259.1	172.5	13.0	197.9	149.0	9.9
	6800			246.5	172.1	11.7	188.3	149.9	9.0			276.5	188.4	13.8	211.2	163.3	10.6
45	5200	18.0	2.0	142.2	115.7	15.8	108.6	102.2	12.1	20	1.7	168.8	128.1	16.9	128.9	112.4	12.9
	6000			144.4	125.5	16.0	122.6	122.6	13.6			172.6	139.2	17.3	131.8	122.9	13.2
	6800			150.5	136.6	16.7	131.8	131.8	14.6			181.1	152.2	18.1	156.4	156.4	15.6
	5200	30.0	5.3	178.3	129.1	11.9	136.1	112.9	9.1	30	3.6	200.3	140.1	13.4	153.0	121.9	10.2
	6000			188.7	141.7	12.6	144.1	124.4	9.6			211.7	153.9	14.1	161.7	134.5	10.8
	6800			198.7	154.0	13.2	151.7	135.6	10.1			224.2	168.2	14.9	171.2	147.4	11.4
	5200	42.0	10.1	197.2	136.4	9.4	150.6	118.6	7.2	40	6.3	220.8	148.2	11.0	168.6	128.2	8.4
	6000			212.8	150.8	10.1	162.5	131.6	7.7			237.8	164.0	11.9	181.6	142.4	9.1
	6800			226.2	164.3	10.8	172.7	143.8	8.2			253.7	179.4	12.7	193.8	156.3	9.7
50	5200	18.0	2.0	120.8	108.0	13.4	93.4	93.4	10.4	20	1.7	143.5	118.7	14.3	110.8	110.8	11.1
	6000			122.6	122.6	13.6	102.1	102.1	11.3			146.7	129.8	14.7	121.4	121.4	12.1
	6800			131.8	131.8	14.6	109.8	109.8	12.2			153.9	142.5	15.4	130.4	130.4	13.0
	5200	30.0	5.3	151.5	119.1	10.1	115.7	104.9	7.7	30	3.6	170.3	128.6	11.4	130.0	112.8	8.7
	6000			160.4	131.3	10.7	122.5	116.1	8.2			179.9	142.0	12.0	137.4	125.0	9.2
	6800			168.9	143.2	11.3	122.8	122.8	8.2			190.6	155.7	12.7	145.5	137.5	9.7
	5200	42.0	10.1	167.6	125.1	8.0	128.0	109.7	6.1	40	6.3	187.7	135.2	9.4	143.3	118.0	7.2
	6000			180.8	138.8	8.6	138.1	122.1	6.6			202.1	150.3	10.1	154.3	131.6	7.7
	6800			192.2	151.7	9.2	146.8	133.8	7.0			215.6	165.0	10.8	164.7	144.9	8.2

HOT WATER HEATING CAPACITIES

180SHWC4 (4 ROW COIL)					
180°F ENTERING WATER TEMPERATURE					
CFM	GPM	WTR. P.D. FT.	TOTAL MBH	LVG. AIR °F	LVG. WTR °F
5200	18.0	2.0	411.0	143	134
6000			449.4	139	130
6800			483.2	136	126
5200	30.0	5.3	450.7	150	150
6000			496.9	147	147
6800			540.5	143	144
5200	42.0	10.1	471.7	154	157
6000			521.8	150	155
6800			570.0	148	153

180HWK (2 ROW COIL)					
180°F ENTERING WATER TEMPERATURE					
CFM	GPM	WTR. P.D. FT.	TOTAL MBH	LVG. AIR °F	LVG. WTR °F
5200	17.0	1.9	308.7	125	144
6000			332.3	121	141
6800			352.6	118	138
5200	25.0	4.1	332.3	129	153
6000			360.2	125	151
6800			386.1	123	149
5200	35.0	8.0	347.8	132	160
6000			378.5	128	158
6800			407.5	125	157

* 70 degree return air

* 70 degree return air

- Notes:**
- 1) See page 22 for hot water heating correction factors.
 - 2) Optional 6 row coils should not be used for heating.
 - 3) Optional 2 row hot water coil can be factory installed in either the reheat (std.) or preheat positions.
 - 4) When these units are used with hot water coil the leaving air temperature must not exceed 150 degrees. At high altitude conditions, blower motor may cutout at a lower LAT. Contact factory for information.

SHWC SERIES

240SHWC CHILLED WATER COOLING CAPACITIES

ENT. WTR. °F	C.F.M.	240SHWC4 (4 ROW COIL)									240SHWC6 (6 ROW COIL)								
		G.P.M.	WTR. P.D. FT.	80°F DB/67°F WB ENT. AIR			75°F DB/63°F WB ENT. AIR			G.P.M.	WTR. P.D. FT.	80°F DB/67°F WB ENT. AIR			75°F DB/63°F WB ENT. AIR				
				TOTAL MBH	SENS. MBH	TEMP. RISE	TOTAL MBH	SENS. MBH	TEMP. RISE			TOTAL MBH	SENS. MBH	TEMP. RISE	TOTAL MBH	SENS. MBH	TEMP. RISE		
42	6000	40.0	5.2	242.0	164.0	12.1	185.0	142.0	9.2	40	5.2	268.0	177.0	13.4	205.0	152.0	10.2		
	8000			276.0	198.0	13.8	210.0	173.0	10.5			308.0	215.0	15.4	235.0	187.0	11.7		
	10000			299.0	228.0	14.9	228.0	200.0	11.4			337.0	250.0	16.9	258.0	219.0	12.9		
	6000	50.0	8.0	259.0	170.0	10.4	198.0	147.0	7.9	50	8.0	289.0	185.0	11.6	221.0	159.0	8.8		
	8000			300.0	207.0	12.0	229.0	180.0	9.2			337.0	227.0	13.5	258.0	196.0	10.3		
	10000			330.0	329.0	13.2	252.0	209.0	10.1			375.0	264.0	15.0	287.0	230.0	11.5		
	6000	60.0	11.3	270.0	175.0	9.0	206.0	151.0	6.9	60	11.3	304.0	191.0	10.1	233.0	164.0	7.8		
	8000			316.0	214.0	10.5	241.0	185.0	8.0			360.0	236.0	12.0	275.0	203.0	9.2		
	10000			351.0	247.0	11.7	268.0	216.0	8.9			405.0	276.0	13.5	309.0	239.0	10.3		
45	6000	40.0	5.2	222.0	156.0	11.1	170.0	136.0	8.5	40	5.2	246.0	168.0	12.3	188.0	145.0	9.4		
	8000			253.0	189.0	12.6	193.0	166.0	9.7			282.0	205.0	14.1	216.0	179.0	10.8		
	10000			274.0	219.0	13.7	209.0	193.0	10.5			309.0	239.0	15.5	236.0	210.0	11.8		
	6000	50.0	8.0	238.0	162.0	9.5	181.0	141.0	7.3	50	8.0	265.0	175.0	10.6	202.0	151.0	8.1		
	8000			275.0	198.0	11.0	210.0	173.0	8.4			309.0	216.0	12.4	236.0	188.0	9.5		
	10000			302.0	229.0	12.1	231.0	201.0	9.2			344.0	252.0	13.8	263.0	221.0	10.5		
	6000	60.0	11.3	248.0	166.0	8.3	189.0	144.0	6.3	60	11.3	279.0	181.0	9.3	213.0	156.0	7.1		
	8000			290.0	203.0	9.7	221.0	177.0	7.4			330.0	224.0	11.0	252.0	194.0	8.4		
	10000			322.0	237.0	10.7	246.0	207.0	8.2			371.0	263.0	12.4	283.0	229.0	9.4		
50	6000	40.0	5.2	189.0	143.0	9.4	144.0	126.0	7.2	40	5.2	209.0	153.0	10.5	169.0	134.0	8.0		
	8000			215.0	175.0	10.7	164.0	155.0	8.2			230.0	189.0	12.0	183.0	167.0	9.2		
	10000			233.0	204.0	11.6	175.0	175.0	8.7			263.0	222.0	13.1	201.0	201.0	10.0		
	6000	50.0	8.0	202.0	148.0	8.1	154.0	130.0	6.2	50	8.0	225.0	160.0	9.0	178.0	140.0	7.1		
	8000			234.0	182.0	9.3	178.0	161.0	7.1			263.0	198.0	10.5	201.0	174.0	8.0		
	10000			257.0	212.0	10.3	182.0	182.0	7.3			293.0	233.0	11.7	223.0	205.0	8.9		
	6000	60.0	11.3	211.0	152.0	7.0	161.0	132.0	5.4	60	11.3	237.0	164.0	7.9	187.0	146.0	6.2		
	8000			246.0	187.0	8.2	188.0	164.0	6.3			281.0	205.0	9.4	214.0	179.0	7.1		
	10000			274.0	219.0	9.1	210.0	193.0	6.9			315.0	242.0	10.5	241.0	212.0	8.0		

HOT WATER HEATING CAPACITIES

240SHWC4 (4 ROW COIL)					
180°F ENTERING WATER TEMPERATURE					
CFM	GPM	WTR. P.D. FT.	TOTAL MBH	LVG. AIR °F	LVG. WTR °F
6000	40.0	5.2	547	154	153
8000			664	147	147
10000			768	141	142
6000	50.0	8.0	561	157	158
8000			687	150	153
10000			799	144	148
6000	60.0	11.3	571	158	161
8000			702	151	157
10000			819	146	153

* 70 degree return air

240HWK (2 ROW COIL)					
180°F ENTERING WATER TEMPERATURE					
CFM	GPM	WTR. P.D. FT.	TOTAL MBH	LVG. AIR °F	LVG. WTR °F
6000	15.0	0.9	323	120	137
8000			369	113	131
10000			415	108	125
6000	25.0	2.3	361	126	151
8000			420	119	146
10000			457	112	144
6000	35.0	4.3	382	192	158
8000			449	122	154
10000			494	116	152

* 70 degree return air

- Notes:**
- 1) See page 22 for hot water heating correction factors.
 - 2) Optional 6 row coils should not be used for heating.
 - 3) Optional 2 row hot water coil can be factory installed in either the reheat (std.) or preheat positions.
 - 4) When these units are used with hot water coil the leaving air temperature must not exceed 150 degrees. At high altitude conditions, blower motor may cutout at a lower LAT. Contact factory for information.

SHWC SERIES

HOT WATER HEATING CORRECTION FACTORS

ENTERING AIR TEMP. (°F)	ENTERING WATER TEMPERATURE (°F)								
	100	110	120	130	140	150	160	170	180
50	0.455	0.545	0.636	0.727	0.818	0.909	1.000	1.091	1.182
55	0.409	0.500	0.591	0.682	0.773	0.864	0.955	1.045	1.136
60	0.363	0.455	0.545	0.636	0.727	0.818	0.909	1.000	1.091
65	0.318	0.409	0.500	0.591	0.682	0.773	0.864	0.955	1.045
70	0.272	0.363	0.455	0.545	0.636	0.727	0.818	0.909	1.000
75	0.227	0.318	0.409	0.500	0.591	0.682	0.773	0.864	0.955
80	0.182	0.272	0.363	0.455	0.545	0.636	0.727	0.818	0.909

Notes:

- 1) To determine heating capacity at other than 180 deg. E.W.T. and 70 deg. E.A.T. multiply the selected heating capacity at 180 deg. times the appropriate correction factor from above chart.
- 2) These correction factors may be used on all First Co. published 180 deg. heating capacities.
- 3) When **SHWC** units are used for hot water heating the leaving air temperature must not exceed 150 degrees. At high altitude conditions, blower motor may cutout at a lower LAT. Contact factory for information.



GUIDE SPECIFICATIONS

Furnish and install First Co. **SHWC** Series Blower - Coil units as indicated on the plans.

CABINETS

Cabinets shall be manufactured of heavy gauge galvanized steel. The entire interior of the cabinet shall be insulated with one inch thick IAQ type insulation. Removable access panels shall be provided on both sides of the cabinet for maintenance and service. All cabinets shall have 2" supply and 1" return flanges.

INSULATION

The entire interior of the cabinet shall be insulated with one (1) inch insulation. This insulation must meet the requirements of ASTM C 1071, ASTM G 21, ASTM G 22, NFPA 90A, UL-181, and the cleaning practices of NAIMA.

MOTOR / BLOWERS

Blowers shall be resiliently mounted, with ball bearings, forward curved blade, and of centrifugal type. Each wheel shall be dynamically balanced for smooth, quiet operation. Blowers shall be belt driven with field adjustable pulleys to permit variations in static pressure and air requirements. Standard motors are 1725 RPM either single or three phase. All motors to be field or factory installed and wired at voltage specified by customer.

COILS

All **SVWC** series coils shall consist of aluminum fins mechanically bonded onto 3/8" or 1/2" OD seamless copper tubing. All coils shall be leak tested at 350 PSIG minimum air pressure. Manual air vents shall be standard on all coils.

Drain pans shall be coated for corrosion protection.

FILTERS

One inch throw away filters are standard in 2-5 ton **SHWC** units. One inch permanent filters are provided as standard in 7-20 ton **SHWC** units. Filters shall be accessible without tools.

LISTING

All standard motors are ETL Listed. All air handlers shall be rated in accordance with ARI Standard 430. Standard motors have internal overload protection. Therefore, units shipped with standard motors will be ETL listed. Most non-standard motors (i.e. 575V, 2-speed, TEFC, some 50 Hz., etc.) are not available with internal overload protection. Therefore, most units shipped with non-standard motors can be ETL listed with the addition of a factory installed motor starter (contact the factory for starter information and ETL verification.)



FIRST CO.
P.O. BOX 270969 - DALLAS, TEXAS 75227
PH. (214) 388-5751 | SALES@FIRSTCO.COM
WWW.FIRSTCO.COM