

# Installation, Operation, & Maintenance

IOM 8512  
Rev. B 03/26

## Fresh Pak HP (EPE) Space Constrained Heat Pump w/ Energy Recovery Ventilation

**eco**series  
FRESH-PAK®

### ATTENTION:

Read all instructions thoroughly and retain all manuals for future reference.

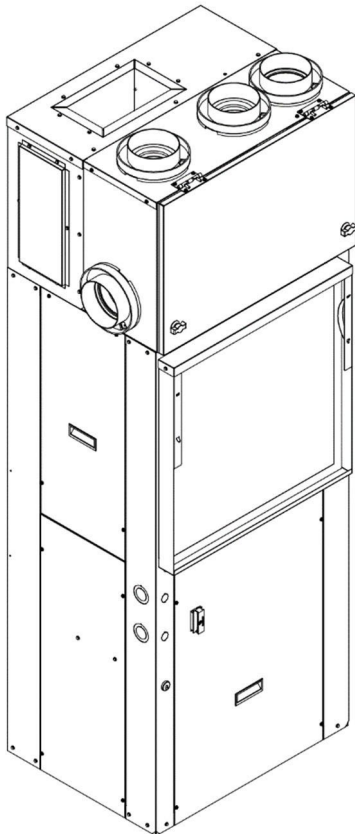

**AHRI** CERTIFIED®  
[www.ahridirectory.org](http://www.ahridirectory.org)

Unitary Small HP  
AHRI Standard 210/240  
Certification applies only when the complete system  
is listed with AHRI.

## COPYRIGHT

The Manufacturer works to continually improve its products and as a result, it reserves the right to change design and specifications without notice.

The warranty may be void unless the Startup & Performance Checklist is completed and returned to the warrantor. If the FRESH-PAK unit is not installed properly the warranty will be void as the manufacturer cannot be held accountable for problems that stem from improper installation.



## WARNING



This appliance is not to be used by persons (including children) with reduced physical, sensory or mental capabilities, or lack of experience and knowledge, unless they have been given supervision or instruction concerning use of the appliance by a person responsible for their safety

Children should be supervised to ensure that they do not play with the appliance

Use adequate personal protection equipment when installing and performing maintenance. After switching off and locking-out an electrical disconnect, verify a safe condition with an electrical tester. Discharge a capacitor before handling any PSC motor and wiring. Use eye protection, cut resistant gloves and sleeves to protect against metal edges and screws.

Do not alter this product by using non-authorized parts. Such action voids all warranties or implied warranties and may result in adverse operation and performance and may be hazardous to service personnel and occupants. Company employees and/or contractors are not authorized to waive this warning.

# TABLE OF CONTENTS



---

SAFETY CONSIDERATIONS	4
MODEL NOMENCLATURE	5
GENERAL INFORMATION	6
UNIT OPERATION	7
STORAGE	7
SHIPPING & PACKAGING LIST	8
UNIT INSPECTION CHECKLIST	9
UNIT DIMENSIONS	10-11
UNIT PHYSICAL DATA	12
ELECTRICAL DATA	13
INSTALLATION	14-23
ELECTRICAL	24
CONTROLS	25-34
DEFROST DUCTING CONSIDERATIONS	35-37
BLOWER DATA	38-39
FIELD ERV ACCESSORIES	40-41
MAJOR COMPONENTS	42
WIRING DIAGRAMS	43-48
CIRCUIT SCHEMATIC	49
STARTUP INSTRUCTIONS	50-51
STARTUP & PERFORMANCE CHECKLIST INSTRUCTIONS	51
TROUBLE SHOOTING	52-53
OPERATION & MAINTENANCE	54-59
PERFORMANCE TABLES	60
SUPPORT MATERIAL	61
STARTUP & PERFORMANCE CHECKLIST	62-63
NOTES	64



## SAFETY CONSIDERATIONS

1. READ THE ENTIRE MANUAL BEFORE STARTING THE INSTALLATION.
2. Improper installation, adjustment, alteration, service, maintenance, or use can cause explosion, fire, electrical shock, or other conditions which may cause personal injury damage.
3. Consult a qualified licensed installer, service agency, or your distributor for information assistance. The qualified licensed installer or service agency must use factory-authorized kits or accessories when servicing this product.
4. Refer to the individual instructions packaged with kits or accessories when installing.
5. Follow all safety codes.
6. Read these instructions thoroughly and follow all warnings or cautions attached to the unit. Consult local building codes and National Electrical Code (NEC) for special requirements.



### RECOGNIZE THE FOLLOWING SAFETY NOTATIONS THROUGHOUT THIS MANUAL AND POSTED ON THE EQUIPMENT:



 **WARNING** 

Indicates a potentially hazardous situation or unsafe practices that could result in severe personal injury or death and/or damage to property.

 **NOTE** 

Used to highlight suggestions, which may result in enhanced installation, reliability or operation.

 **WARNING** 

 **ELECTRIC SHOCK HAZARD** 



Signifies potential electrical shock hazards that could result in personal injury or death.



 **CAUTION** 

Indicates a potentially hazardous situation that may result in minor or moderate personal injury.

 **IMPORTANT** 

Suggests important procedure steps to insure proper installation, reliability, or operation.

 **WARNING** 

 **FIRE OR EXPLOSION HAZARD** 

Failure to follow safety warnings exactly could result in property damage, dangerous operation, serious injury, or death. Improper servicing could result in dangerous operation, serious injury, death, or property damage.

- Before servicing, disconnect all electrical power to the unit.
- When servicing controls, label all wires prior to disconnecting. Reconnect wires correctly.

Verify proper operation after servicing

# MODEL NOMENCLATURE

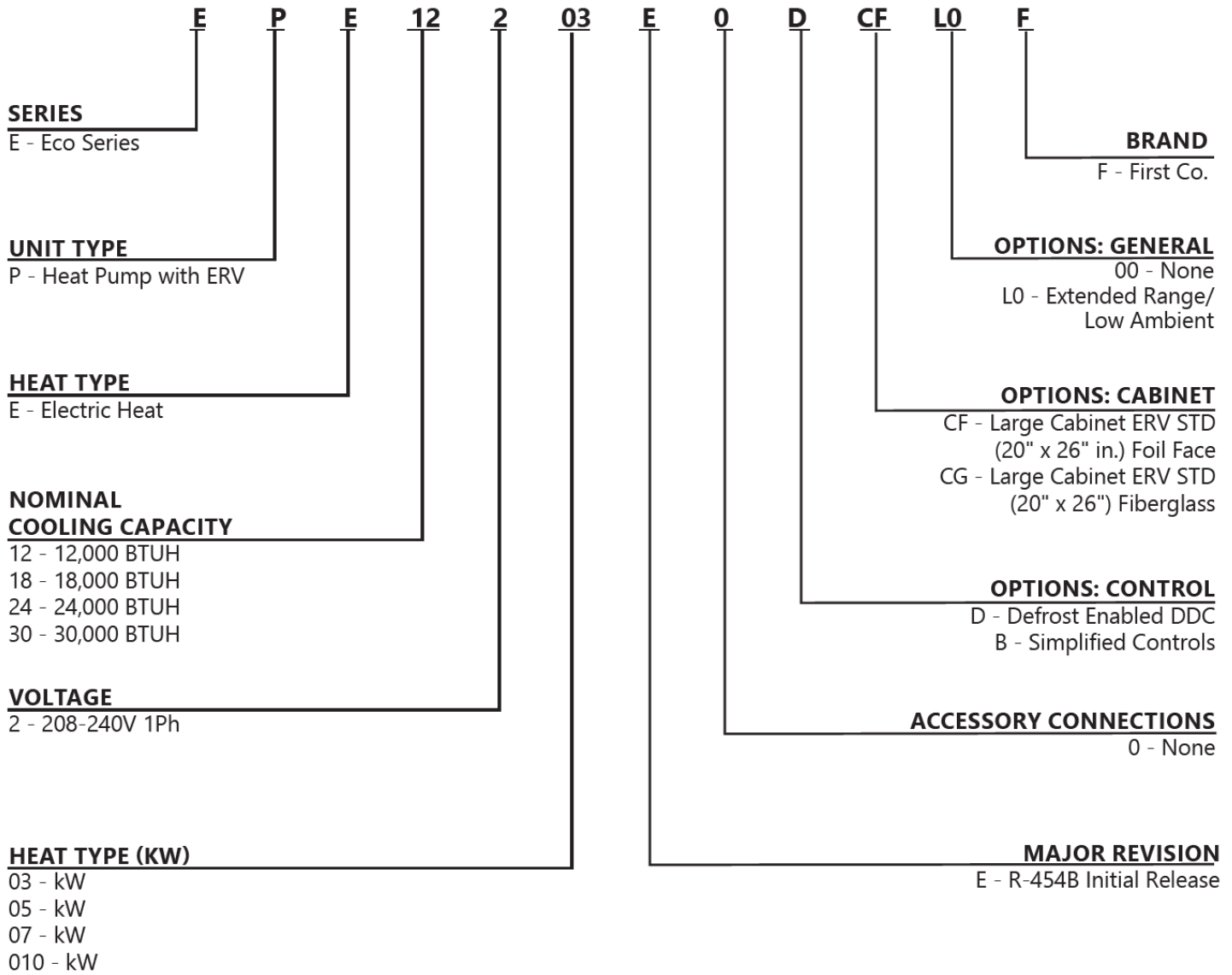



Figure 1 - Model Nomenclature



## GENERAL INFORMATION



The FRESH-PAK unit is a combination of our high efficiency, high performance and reliable vertically packaged heat pump unit with an integral Energy Recovery Ventilation (ERV) System. ERVs provide pre-conditioned fresh outdoor air to your space either directly or through the normal return of your air handling unit. The benefits include improved indoor air-quality, reduced energy costs and lower first cost of installation. The FRESH-PAK EPE models come standard with ECM blowers for high efficiency and comfort, integrated defrost controls allowing compressor operation down to 5°F, and features a range of auxiliary electric heat sizes. All FRESH-PAK models are certified to AHRI Standard 210/240-2020 and are compliant with UL60335-2-40.



These instructions are given for the installation of the Eco Series Fresh-Pak EPE models specifically. For any other related equipment, refer to the appropriate manufacturer's instructions.

This unit may be installed at altitudes up to 10,000 ft. (3,048 m).



	<b>WARNING</b>	
This unit is certified for through-the-wall indoor installation only. It is NOT approved for mobile homes, recreational vehicles or outdoor applications. Such use could result in property damage, personal injury, or death.		





	<b>IMPORTANT</b>	
Do not operate this unit in any mode during building construction due to excessive airborne dust and debris. Do not operate this unit without an air filter in place. The manufacturer does not warrant equipment subjected to abuse.		

	<b>NOTE</b>	
Material in this shipment has been inspected at the factory and released to the transportation agency in good condition.		
Upon receipt, a visual inspection of all cartons should be made immediately. Any evidence of rough handling or apparent damage should be noted on the delivery receipt in the presence of the carrier's representative.		
If damage is found, a claim should be immediately filed against the carrier.		

	<b>WARNING</b>	
Take extreme caution that no internal damage will result if screws or holes are drilled into the cabinet.		

	<b>CAUTION</b>	
Do not operate this unit without an air filter in place.		

	<b>NOTE</b>	
Remove shrink-wrap and all packaging materials before installation. Ensure louvered areas are free from obstructions before installation.		

	<b>WARNING</b>	
	<b>ELECTRIC SHOCK HAZARD</b>	
Before servicing equipment, <b>ALWAYS</b> turn off all power to the unit. There may be more than one disconnect switch. Electrical shock can cause injury or death		

## UNIT OPERATION

### **IMPORTANT**

The unit is designed to operate at maximum 0.5 in.w.c external static pressure. Operation at higher E.S.P may cause equipment failure. For applications requiring higher static operation, please contact factory or the manufacture’s sales representative.

### **WARNING**

These instructions are intended as an aid to qualified, licensed, service personnel for proper installation, adjustment and operation of this unit. Read these instructions thoroughly before attempting installation or operation. Failure to follow these instructions may result in improper installation, adjustment, service or maintenance possibly resulting in fire, electrical shock, property damage, personal injury or death.

Unit Operating Range °F [°C]				
Condition	Cooling		Heating	
	Min	Max	Min	Max
Outdoor DB	60 [15.6]	115 [46.1]	5 [-15]	75 [23.8]
Indoor DB	60 [15.6]	90 [32.2]	50 [10]	80 [26.6]

**Table 1 – Unit Operating Range**

Note:

- 1) Operating ranges based off standard installation with “0” external static and standard Louvers. Operation with non-standard louvers may lower unit operating range.

## STORAGE

Equipment should be stored in a clean dry, conditioned area with maximum temperatures up to 120°F [48.89°C] and minimum temperatures to 32°F [0°C]. Units should be stored upright and in an indoor environment. It is recommended to leave packaging on the unit until the installation is to begin.

### **WARNING**

#### REFRIGERANT UNDER PRESSURE

Units are factory charged with refrigerant. Store units in a location that will minimize the potential for damage. Do not store the unit where sources of ignition are continuously present.

Do not use means to accelerate the defrosting process, or to clean the unit, other than those recommended by the manufacturer.

Be aware that refrigerants may not contain an odour.

Do not pierce or burn.

### **WARNING**

DO NOT stack FRESH-PAK units! Failure to follow these instructions may result in property damage, personal injury or death.

### **WARNING**

Do not operate this unit in any mode during building construction due to excessive airborne dust and debris.

Do not operate this unit without an air filter in place.

The manufacturer does not warrant equipment subjected to abuse.

## SHIPPING & PACKAGING LIST

### SHIPPING INSTRUCTIONS

FRESH-PAK units must remain in the upright position throughout the shipping and handling process to maintain the proper compressor oil level.

### PACKAGE LIST

The units will be shipped with the following. Quantities listed in Paratheses.

1. FRESH-PAK Package Heat Pump Unit with Integral ERV
  - a. Shipping brackets (3)
  - b. Shipping bracket screws (8)
  - c. Sleeve mounting bracket (2)
  - d. Sleeve mounting bracket screws (6)
2. Literature Package containing
  - a. IOM - Installation & Operations Manual (1)
3. Duct Collar Kit
  - a. ERV Round Duct Connections (4)
  - b. Screws (12)

Check the unit for shipping damage; if damage is found, immediately contact the last carrier.

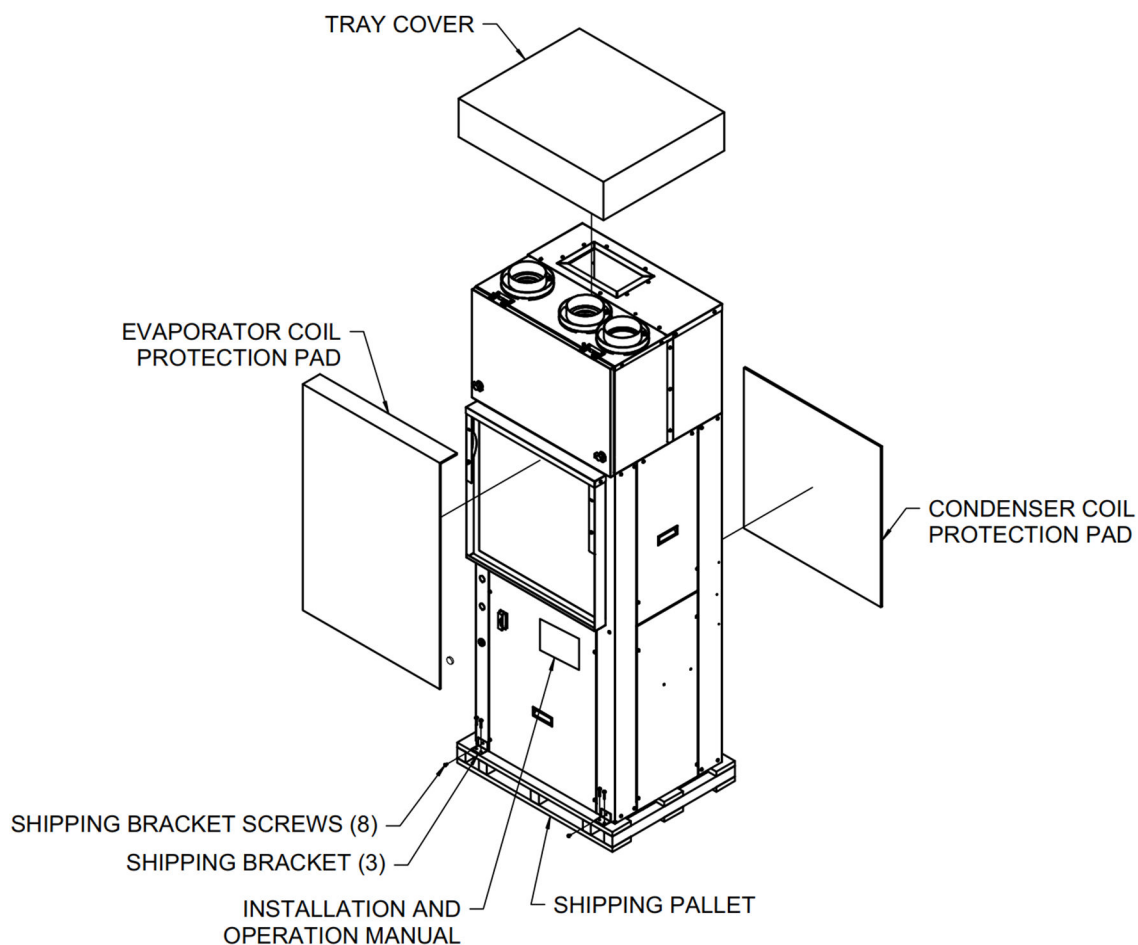

Figure 2 – Standard Packaging

# UNIT INSPECTION CHECKLIST

Before preparing unit for installation, complete the inspection procedures below.

- 1) Visually inspect unit for any shipping damage. Damage must be reported immediately to the shipping company to make a claim.
- 2) Ensure that the carrier makes proper notation of any shortages or damage on all copies of the freight bill and completes a common carrier inspection report.
- 3) Verify that unit nameplates on the data label match the sales order or bill of lading (including, unit configuration, size and voltage).
- 4) Immediately before installation, remove unit front panel and verify that all electrical connections are tight and that there are no loose wires.
- 5) Verify that the refrigerant piping is free from any kinks and there is no interference between unit piping and sheet metal or electrical wires.
- 6) Remove the blower access panel and remove the foam packaging mount underneath the blower.
- 7) Check that the blower spins freely within the housing and there are no obstructions between the wheel and housing. The wheel can sometimes come loose in shipping.
- 8) Ensure that evaporator distributor tubes are not touching one another and that they are over the drain pan.
- 9) Check the air-coil fins for any damage during shipping.
- 10) Ensure that shipping brackets and screws are removed from condensing section. Refer to FIGURE 3 - Standard Packaging with Brackets – Front View & FIGURE 4 - Standard Packaging with Brackets – Back View for more information.

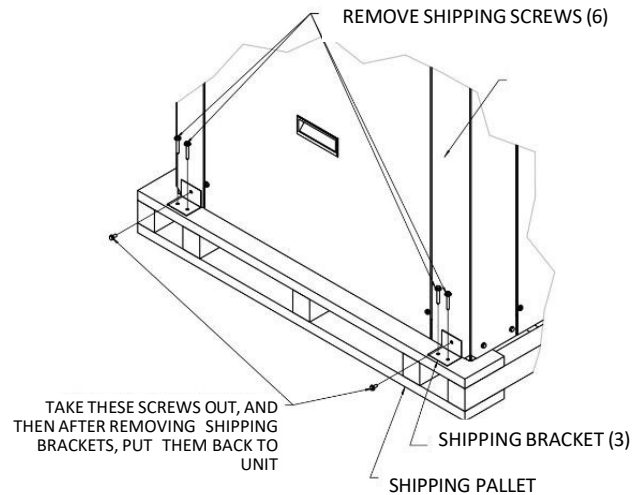

Figure 3 - Standard Packaging with Brackets – Front View

i
NOTE
i

Used to highlight suggestions, which may result in enhanced installation, reliability or operation.

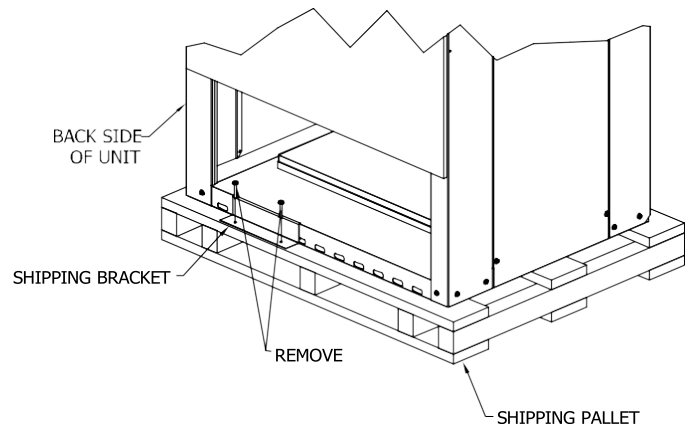

Figure 4 - Standard Packaging with Brackets - Back View

# UNIT DIMENSIONS

## Unit Dimensions 12K

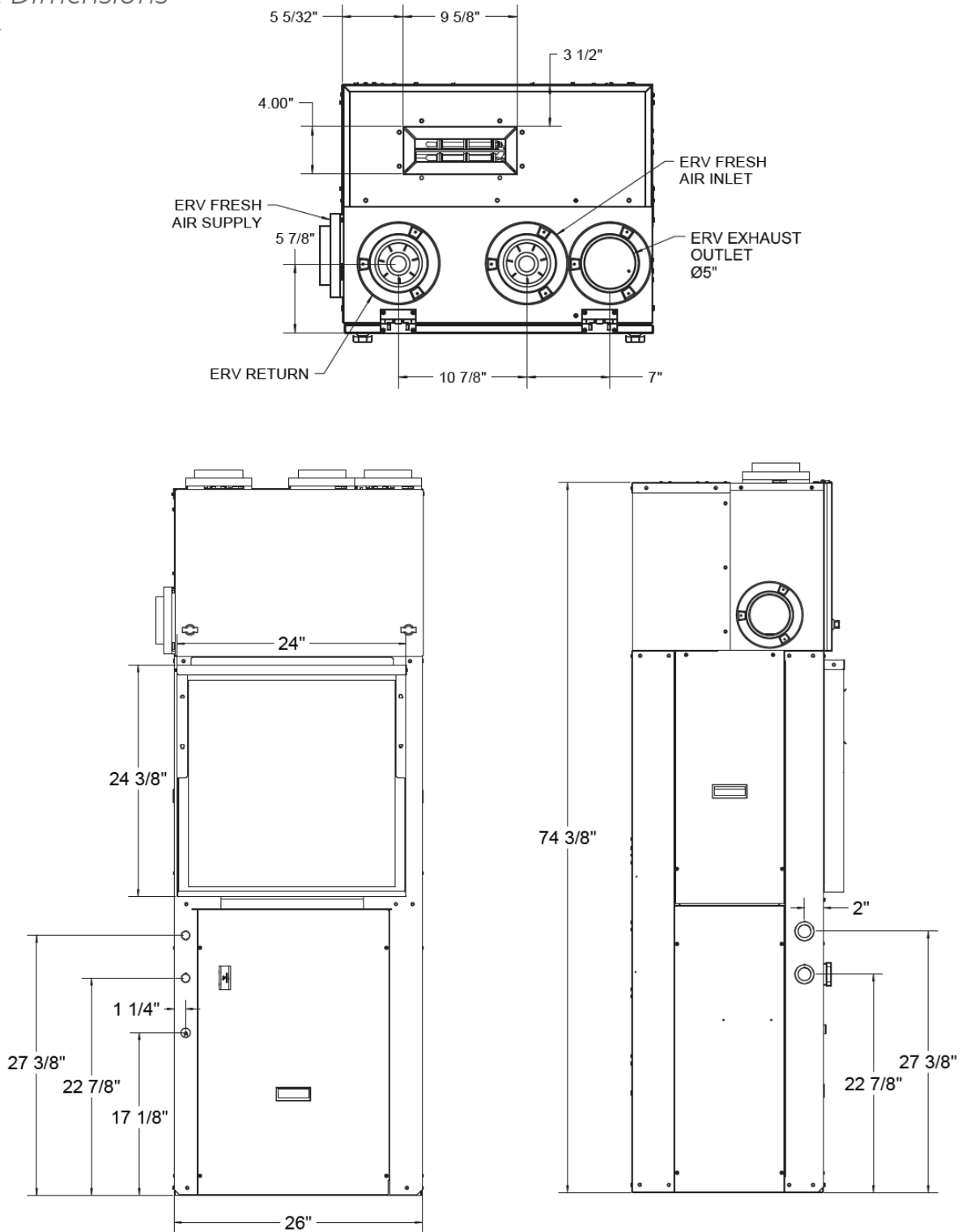

Figure 5 - Unit Dimensions 12K

# UNIT DIMENSIONS (CONTINUED)

## Unit Dimensions

18-30K

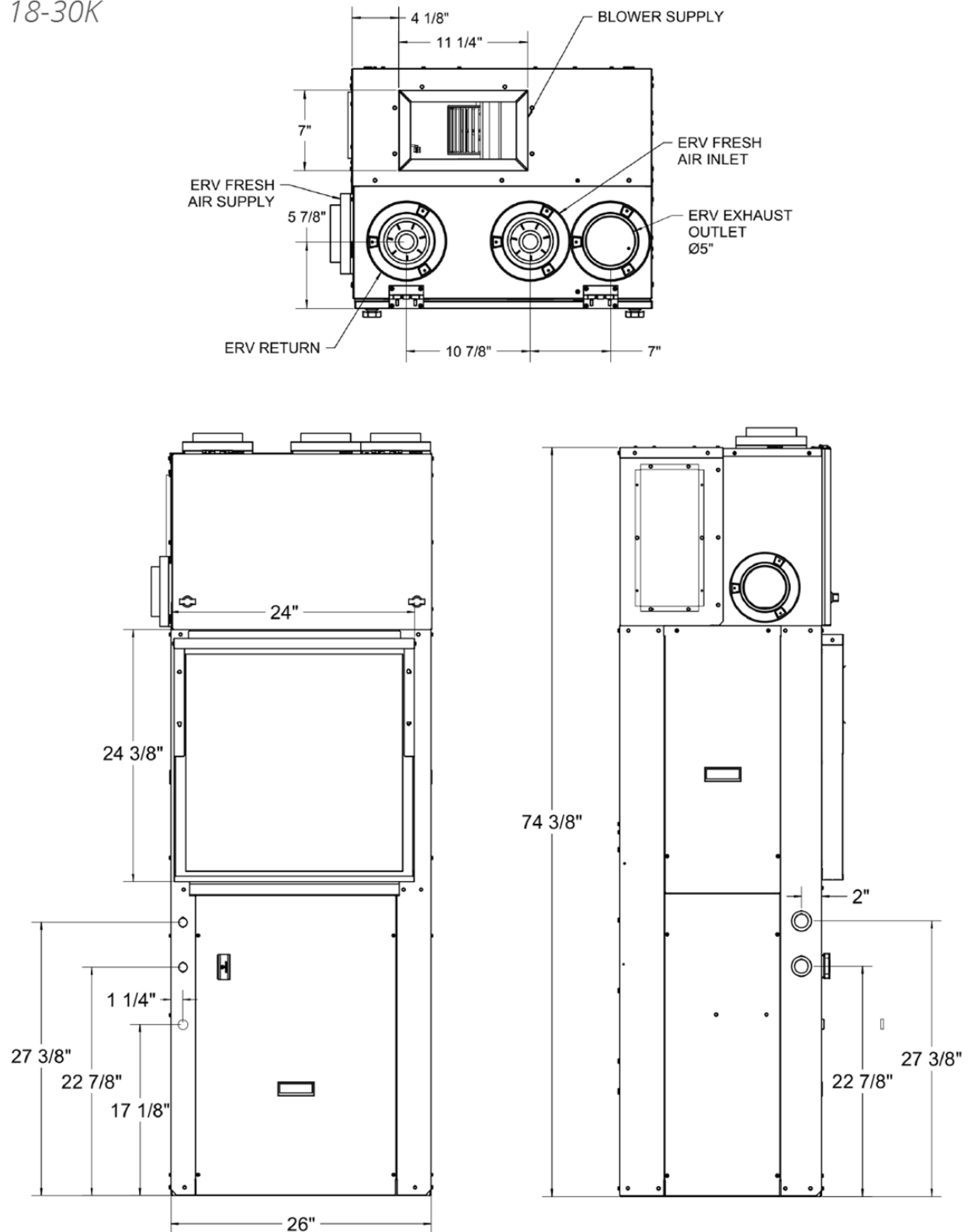

Figure 6 - Unit Dimensions 18-30K

# UNIT PHYSICAL DATA

PHYSICAL DATA					
454B FRESH PAK HP		EPE12	EPE18	EPE24	EPE30
Compressor (Quantity)		Rotary (1)	Scroll (1)	Scroll (1)	Scroll (1)
Compressor FLA		4.6	7.2	10.2	12.8
Factory Charge (R454B)	lb	3.375	4.5	5	5.75
	kg	1.53	2.04	2.26	2.6
Minimum Room Area	m <sup>2</sup>	4.6	6.2	6.8	7.9
Minimum Room Area	Ft <sup>2</sup>	49.7	66.3	73.5	84.5
Minimum Air Flow	CFM	91	122	135	155
	M3/hr	155	207	229	264
ID MOTOR					
Motor (Quantity)		1	1	1	1
Fan Motor Type		ECM	ECM	ECM	ECM
Motor HP		1/4	1/3	1/3	1/2
Motor FLA		2.3	2.8	2.8	4.1
OD MOTOR					
Motor (Quantity)		1	1	1	1
Fan Motor Type		ECM	ECM	ECM	ECM
Motor HP		1/4	1/3	1/3	1/3
Motor FLA		2.3	2.8	2.8	2.8
ID BLOWER					
Blowers (Quantity)		1	1	1	1
Blower Wheel Size (D x W) in. [cm]		6 x 8	10 x 4	10 x 4	10 x 4
		[15.24 x 20.32]	[25.4 x 10.16]	[25.4 x 10.16]	[25.4 x 10.16]
EVAPORATOR COIL					
Dimensions (H x W) in. [cm]		24 x 16.25	24x22	24x22	24x22
		[61 x 41.275]	[61 x 55.88]	[61 x 55.88]	[61 x 55.88]
Face Area ft <sup>2</sup> [m <sup>2</sup> ]		3.53 [2.70]	3.53 [0.33]	3.53 [0.33]	3.53 [0.33]
Rows		3	4	4	4
OD COIL					
Dimensions (H x W) in. [cm]		26 x 16.5	26 x 22.5	26 x 22.5	26 x 22.5
		[66 x 42]	[66 x 57]	[66 x 57]	[66 x 57]
Face Area ft <sup>2</sup> [m <sup>2</sup> ]		3.0 [0.2772]	4.1 [0.3762]	4.1 [0.3762]	4.1 [0.3762]
MISCELLANEOUS					
Throwaway Filter Dim. in. [cm]		24 x 24	24 x 24	24 x 24	24 x 24
		[60.96 x 60.96]	[60.96 x 60.96]	[60.96 x 60.96]	[60.96 x 60.96]
Throwaway Filter Quantity		1	1	1	1
A2L MITIGATION		NO	YES	YES	YES
Operating Weight lb. [kg]		275 [124.7]	290 [131.5]	305 [138.3]	310 [140.6]
Packaged Weight lb. [kg]		295 [133.8]	310 [140.6]	325 [147.4]	330 [149.7]

Table 2 – Physical Data

Data is subject to change. Please verify most current information on [www.firstco.com](http://www.firstco.com) or [www.AE-Air.com](http://www.AE-Air.com) websites.

For installations in locations above 800 meters, the room size and mitigation airflow must be adjusted with a factor from this chart:

Altitude Correction Factor													
Altitude (m)	800	1000	1200	1400	1600	1800	2000	2200	2400	2600	2800	3000	3200
Altitude (ft)	2625	3281	3937	4593	5249	5906	6562	7218	7874	8530	9186	9843	10499
Adj Factor (AF)	1.02	1.05	1.07	1.1	1.12	1.15	1.18	1.21	1.25	1.28	1.32	1.36	1.4

Table 3 – Altitude Correction Factor

# ELECTRICAL DATA

Electrical Data													
UNIT MODEL		ELECTRICAL HEAT DATA						BLOWER DATA		CONDENSER DATA			
		KW		BTUH		TOTAL HEATING AMPS		EVAPORATOR MOTOR		COMPRESSOR		CONDENSER MOTOR	
		240V	208V	240V	208V	240V	208V	AMPS	HP	RLA	LRA	AMPS	HP
EPE12	-03	3	2.25	10230	7670	13	11	2.3	1/4	4.6	25	2.3	1/4
	-05	4.5	3.38	15350	11530	19	16	2.3	1/4	4.6	25	2.3	1/4
EPE18	-03	3	2.25	10230	7670	13	11	2.8	1/3	7.6	36	2.8	1/3
	-05	5	3.75	17060	12790	21	18	2.8	1/3	7.6	36	2.8	1/3
	-07	7	5.25	23880	17910	29	25	2.8	1/3	7.6	36	2.8	1/3
	-10	9.5	7.125	32410	24310	40	34	2.8	1/3	7.6	36	2.8	1/3
EPE24	-05	5	3.75	17060	12790	21	18	2.8	1/3	10.2	58	2.8	1/3
	-07	7	5.25	23880	17910	29	25	2.8	1/3	10.2	58	2.8	1/3
	-10	9.5	7.125	32410	24310	40	34	2.8	1/3	10.2	58	2.8	1/3
EPE30	-05	5	3.75	17060	12790	21	18	4.1	1/2	12.8	77	2.8	1/3
	-07	7	5.25	23880	17910	29	25	4.1	1/2	12.8	77	2.8	1/3
	-10	9.5	7.125	32410	24310	40	34	4.1	1/2	12.8	77	2.8	1/3

Table 4 – Electrical Data

Electrical Data									
UNIT MODEL		MINIMUM CIRCUIT AMAPACITY				MAXIMUM CIRCUIT PROTECTION			
		CKT 1		CKT 2		CKT 1		CKT 2	
		240V	208V	240V	208V	240V	208V	240V	208V
EPE12	-03	26	24	0	0	30	25	0	0
	-05	34	31	0	0	35	35	0	0
EPE18	-03	30	28	0	0	35	30	0	0
	-05	41	37	0	0	45	40	0	0
	-07	51	46	0	0	55	50	0	0
	-10	15	15	49	43	15	15	50	45
EPE24	-05	44	41	0	0	45	45	0	0
	-07	55	50	0	0	55	50	0	0
	-10	18	18	49	43	25	25	50	45
EPE30	-05	49	45	0	0	55	50	0	0
	-07	59	54	0	0	60	55	0	0
	-10	23	23	49	43	30	30	50	45

Table 5 – Electrical Data

Note:  
 Size 12 models require 1 electrical circuit  
 Size 18,24 & 30 models require 2 electrical circuit for 10kW electric heat only.  
 \*Circuits 1 and 2 require separate sets of power wires connected to the unit, each backed by an independent circuit breaker.  
 Size 12 models circuit 1 powers all components  
 Size 18,24 & 30 models, circuit 1 powers compressor, condenser fan and evaporator motor. Circuit 2 powers both stages of electric heat  
 Refer to wiring diagrams in the EPE IOM for additional details.  
 Wire size should be determined in accordance with National Electric Codes  
 Units are rated for 208/240V, but MOP, MCA values are calculated at 208/240V  
 \*Data is subject to change. Please Verify most current information on [www.firstco.com](http://www.firstco.com) or [www.AE-Air.com](http://www.AE-Air.com)

# INSTALLATION

## INSTALLATION PRECAUTIONS

**CAUTION**

Always wear all appropriate personal protection Equipment when installing and servicing units.

**WARNING**

Use multiple people to team lift when moving and installing these units.

Failure to properly lift units may result in personal injury or death.

**CAUTION**

Contact with metal edges and corners can result in personal injury. Protective gloves should be worn when handling. Exercise caution when installing and servicing unit.

Observe the following precautions for typical installation.

- Always use proper tools and equipment
- No wiring or any work should be attempted without first ensuring the unit is completely disconnected from the power source and locked out. Also, verify that a proper permanent and uninterrupted, ground connection exists prior to energizing power to the unit.
- Review unit nameplate and wiring diagram for proper voltage and control configurations. This information may vary from unit to unit.
- Units must be installed level to ensure proper drainage and operation.
- Be sure that the drain pan is free from foreign material prior to start up.

**CAUTION**

Components rotate at high speeds when the unit is in operation.

- Check filter media installation to ensure that it is installed correctly. Use the directional arrows or other information on the filter to determine the proper flow direction.
- Ensure air distribution system does not exceed the external static rating of the unit.

**WARNING**

When soldering and brazing, have a fire extinguisher available. When soldering and brazing close to valves or sensitive components, heat shields or wet rags are required to prevent damage to the valves or components.

**NOTE**

Damaged insulation must be repaired or replaced before the unit is placed back into operation. Insulation loses its insulating properties when wet, damaged, separated or torn.

**CAUTION**

When servicing this equipment, ensure that the reversing valve, expansion device, filter drier and other components are specifically designed for R-454B refrigerant.

## INSTALLATION (continued)



### WARNING



#### FIRE, EXPLOSION HAZARD

Failure to following this warning could result in personal injury, death and/or property damage.

Do not attempt any sealed system repair without first recovering the entire refrigerant charge. R-454B refrigerant and oil mixture could ignite in the presence of a brazing torch flame. Completely recover the refrigerant charge using both the high and low sides of the system and purge the sealed system with nitrogen before brazing any component or tubing.



### WARNING



Installation and service must be performed by a licensed professional installer (or equivalent), service agency. Attempting to install or repair this unit without such background may result in product damage, personal injury or death.

Work with extreme caution to minimize the risk of refrigerant ignition while installing and servicing a system containing a flammable refrigerant. Control the work environment as much as possible while potentially flammable vapors are present. Inform all persons on site about the risks of the nature of the work underway and the necessary safety precautions. Do not work in confined spaces. Test the work area for refrigerant in the air using an intrinsically safe A2L refrigerant leak detector before beginning work. Have a dry powder or CO2 fire extinguisher available. Use proper tools designed for A2L class refrigerants. While working near A2L refrigerants, use only non-sparking tools. Open flames and other ignition sources must not be present except during brazing. Brazing must only take place on evacuated and nitrogen purged refrigerant lines and components that are open to the atmosphere.

Consult local building codes and current editions of the National Electrical Code (NEC) NFPA 70. In Canada, refer to current editions of the Canadian electrical code CSA CEC22.1.



### IMPORTANT



These units are for indoor installation **ONLY!**

# INSTALLATION (continued)

## UNIT LOCATION

This FRESH-PAK unit is certified for through-the-wall, indoor, up-flow vertical position installation only. This appliance is not design certified for installation in mobile homes, recreational vehicles, or outdoors. A factory approved wall sleeve must be used to install the FRESH-PAK unit.

The interior portion of the unit is surrounded by a closet with a rear access, refer to **FIGURE 7 - Condo with FRESH-PAK on Exterior Wall**. The vertical discharge allows for ducting to the top of the room for best air circulation and elimination of cold drafts on occupants. The exterior (grille side) of the unit must have no obstruction (trees, landscape material, etc.) within 30 in. [76.2 cm]. Refer to **FIGURE 8 - Required Building Clearances**.

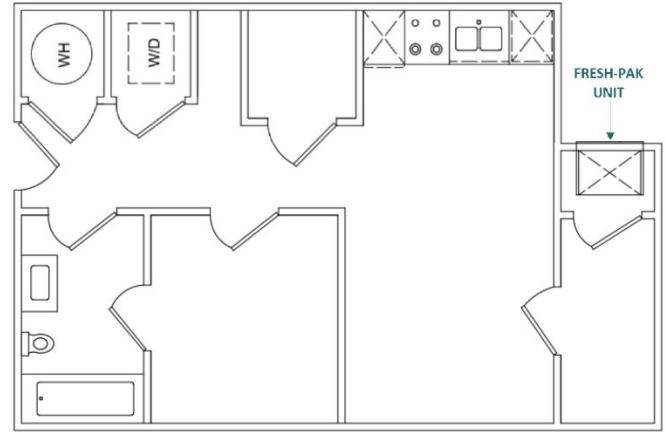

Figure 7 - Condo with Fresh-Pak on Exterior Wall

**i NOTE i**  
Do not locate two units adjacent to each other on an inside corner or where they may exhaust into each other.

Provisions should be made to allow access to the indoor side of the unit for installation and inspection. The closet or access panel opening must be centered with the exterior wall opening and be at least 30 in. [76.2 cm] wide by 84 in. [213.36 cm] tall for all FRESH-PAK models. 6 in. [15.24 cm] of unobstructed clearance must be maintained around the FRESH-PAK chassis for adequate airflow to achieve optimum performance. These guidelines address minimum spacing requirements only. It is acceptable to go beyond these limits at any time. At least 29 in. [73.66 cm] of unobstructed space should be provided in front of the access door to permit removal of the unit, should repair and inspection be required.

**i NOTE i**  
The FRESH-PAK units are designed for quiet operation. However, all air conditioning equipment will transfer a level of noise to the conditioned space. This should be considered when planning the location of the equipment.

**i NOTE i**  
The Architectural Grille must be installed prior to the installation of the FRESH-PAK unit into the sleeve.

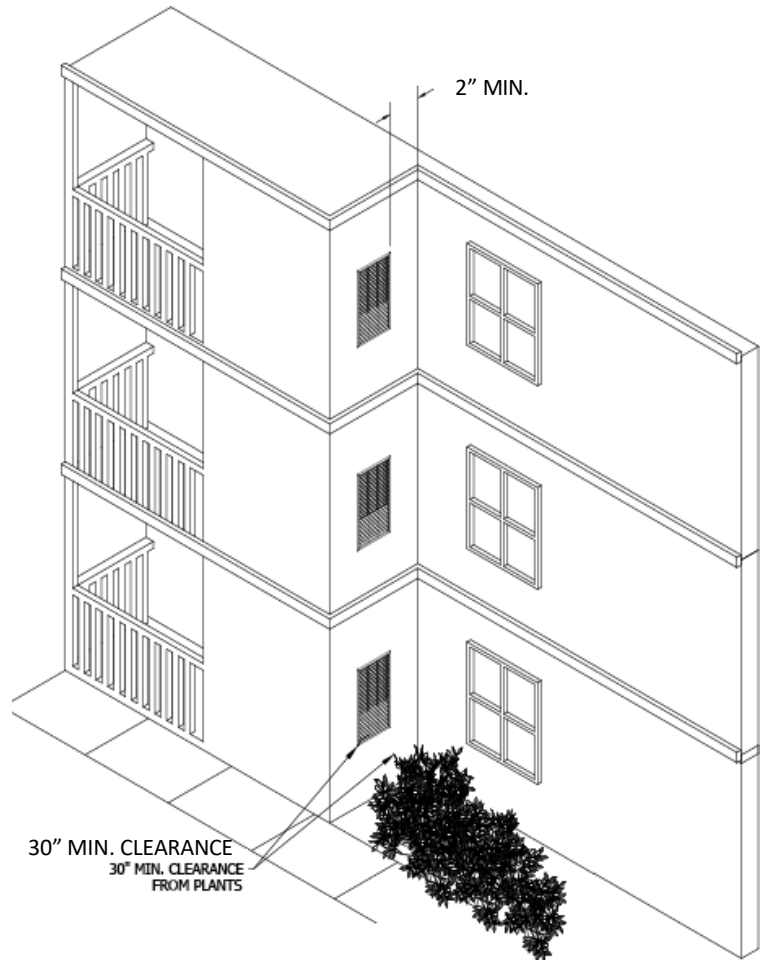

Figure 8 - Required Building Clearances

# INSTALLATION (continued)

## UNIT CLEARANCE REQUIREMENTS

Service clearance must be provided for future maintenance and service. A minimum of 29 in. [73.66 cm] open area must be left unobstructed in front of the access panels.

The louver side must be kept free from any obstructions to air flow. The unit must be installed at least 4 feet [1.22m] from electric meters, gas meters, regulators, and relief equipment.

CLEARANCE REQUIREMENTS		
MINIMUM CLEARANCE	INCHES	CM
Horizontal distance between units	12	30
Vertical distance between units	60	152
Distance above ground level	6	15
Distance above finished floor	6	15
Distance above a garage floor	18	46

**Table 6 - Clearance Requirements**

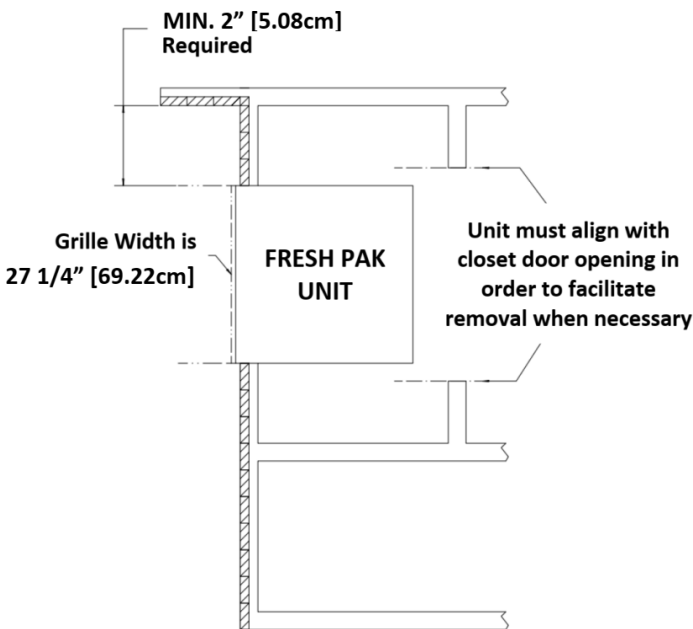

Figure 9 - Clearance Requirements

## WALL SLEEVE INSTALLATION

Refer to installation instruction packed with the wall sleeve to assemble and mount into the wall. Before unit installation, verify that sleeve components are not damaged and that the drain line is unobstructed free of leaks.

Check all seals to ensure that they are in position and undamaged. Ensure that the wall sleeve is sloped toward the exterior of the building to ensure proper overflow drainage. Securely fasten the Architectural louver to the front of the sleeve using the supplied hardware.

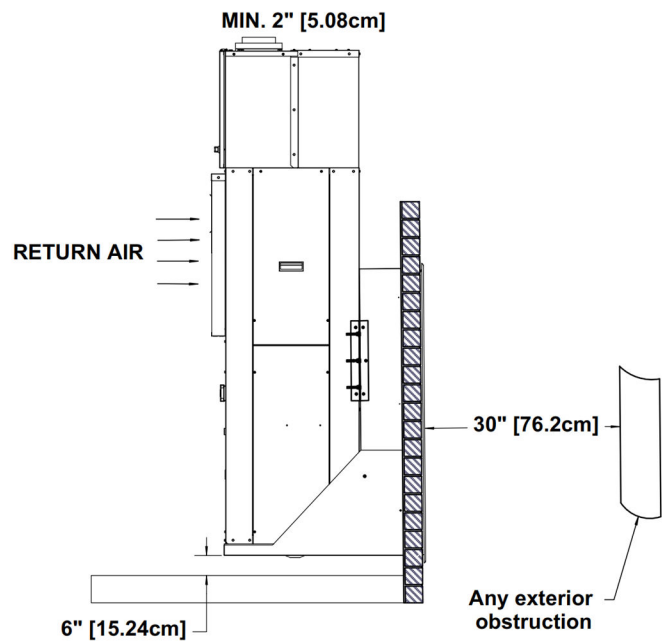

FIGURE 10 - Wall Sleeve Mounting

!

## IMPORTANT

!

After sleeve installation, ensure that the gap in-between the wall and seal is insulated and is in contact with the sleeve sides.

A unit installed in a garage must also be protected from damage by vehicles.

# INSTALLATION (continued)

## WALL SLEEVE INSTALLATION CONTINUED REAR INSTALLATION & DIMENSIONS

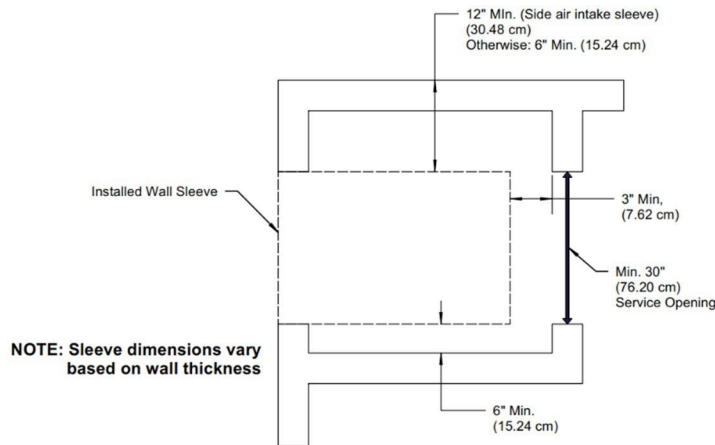

Figure 11 - Rear Installation

- Sleeve rough-in opening is 43-1/2 in. (H) [110.49 cm] x 26-3/4 in. (W) [67.94 cm].
- Bottom of opening should be approximately 6 in. [15.24 cm] above the floor.
- Minimum of 12 in. [30.4 cm] clearance required for side air intake sleeve installation.
- Minimum of 6 in. [15.24 cm] clearance is required on the ERV fresh air (supply air) side.
- Minimum of 3 in. [7.62 cm] of clearance is required on all sides, except ERV fresh air (supply air) side, of the FRESH-PAK unit. See - **FIGURE 11- Rear Installation.**

### ! IMPORTANT !

Apply a high grade non-hardening sealant approved for exterior at the following locations to prevent air and water from migrating inside:

1. Between edge of the sleeve and the structure
2. On the inside/outside walls.

### ! CAUTION !

Contact with metal edges and corners can result in injury. Wear protective gloves when handling. Exercise caution when installing and servicing unit.

### ! CAUTION !

Seal exposed joints to prevent water and outside air infiltration into the closet, which can cause improper unit operation and may cause damage the unit and other property.

**! CAUTION !**

A masonry wall opening must be properly constructed with a lintel for wall support. Wall openings must be flashed and sealed. The unit must be level, front to back, side to side. Refer to CLEARANCE REQUIREMENTS section in this manual for more information.

**i NOTE i**

Locate the unit in an area that easily provides minimum clearance to all service access panels. Consider all additional clearances needed for water connections, electrical connections, duct connections and sufficient return airflow.

## INSTALLATION (continued)

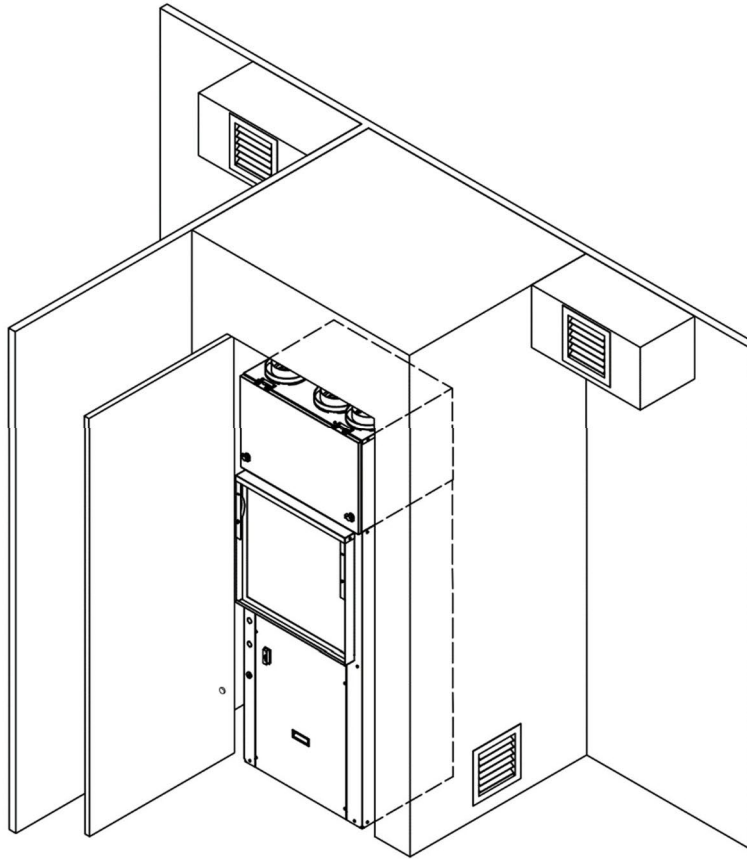

Figure 12 - Fresh-Pak Unit Installation

Insulation is installed in indoor equipment to provide a barrier between outside air conditions surrounding the unit and the varying conditions inside the unit. If the insulating barrier is damaged, the surrounding ambient air will affect the inside surface temperature of the cabinet; this may lead to sheet metal corrosion and subsequently, component failure.

The installer must adhere strictly to all local and national code requirements pertaining to the installation of this equipment. All units are designed for indoor use only, and are agency listed for installation with clearances specified in Table 3- Clearance Requirements. This includes the cabinet, discharge plenum and connecting ducts.

# INSTALLATION (continued)

## PACKAGED UNIT INSTALLATION

1. Remove the three shipping brackets holding the unit to the shipping pallet and remove unit from the shipping pallet.
2. Ensure that properly sized ductwork is in place to mate to the connections on the FRESH-PAK.
3. Before setting unit into closet, remove upper side access panel and inspect the evaporator blower to ensure that the wheel turns freely without rubbing on the housing.

**NOTE**

Remove the foam shipping block supporting the blower assembly.

4. Replace upper access doors prior to completing installation.
5. Remove the disconnect and the rear access door to get to the loose items described in the packaging list. Check all electrical connections and check the condenser fan to see if it turns freely.
6. Remove the 4 ERV duct collars from inside the cabinet.
7. Attach unit mounting brackets (2) as shown in figure 13

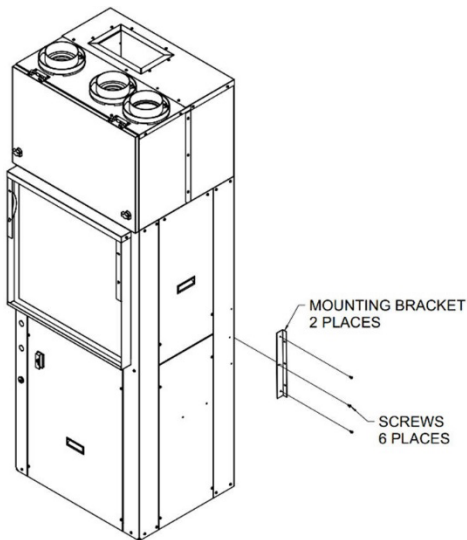

Figure 13 - Mounting Brackets Installation

**CAUTION**

Components rotate at high speeds when the unit is in operation.

8. Ensure that the wall sleeve is installed squarely and is secured before installing the unit.

**IMPORTANT**

After removing the construction debris guard, check the bottom of the sleeve pan to ensure that it is sloped toward the building exterior. Ensure that the bottom of the pan and drain are clear of obstruction and are operational.

**NOTE**

Inspect the sleeve seal, which is supplied with the sleeve, to ensure that it is properly secured and aligned. Use a high-grade non-hardening sealant to close any gaps that may exist between the seal and the wall of the sleeve.

9. After the seal is inspected, lift the unit onto the base of the sleeve and slide the unit forward to engage the seal. The unit uses locking brackets with weld studs. Align the unit to the bracket on the sleeve. Tighten down the unit until there is a tight seal with the sleeve. See **FIGURE 14 - Wall Sleeve Seal**.

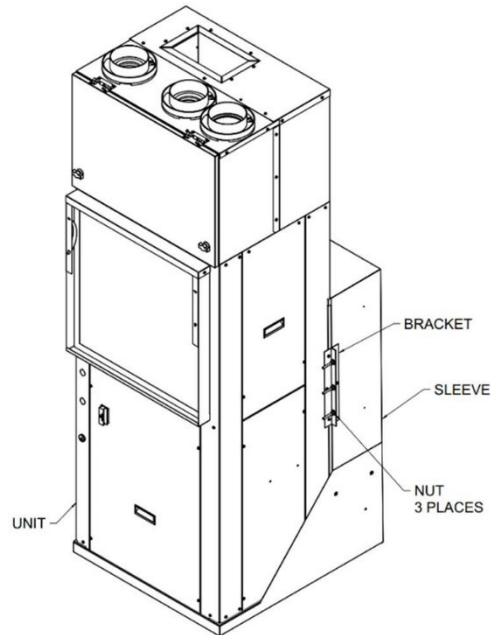

Figure 14 - Wall Sleeve Seal

1. Check that the unit is completely seated on all four sides against the wall sleeve seals.

## INSTALLATION (continued)

### DUCTWORK

Discharge ductwork is normally used with these units. When return air ductwork is required, the unit is supplied with 2 in. [5.08 cm] thick filter rack/duct collar for connection of return air ductwork. All ductwork must be installed in accordance with National Fire Protection Assoc. Codes 90A and 90B.

Supply and Return ducts must be sized properly as to not exceed static pressure capabilities of the unit. Ducts should be adequately insulated to prevent condensation and to minimize heat loss. A flexible connector is recommended for supply air connections on metal duct systems.

### DISCHARGE DUCTING

The unit cabinet must have an uninterrupted and unbroken ground to minimize personal injury if an electrical fault should occur. Provide ground circuit in accordance with all applicable national and local codes

All Ductwork must conform to industry standards of good practice as described in ASHRAE System Guide. The transition piece from the unit discharge to the duct distribution system must not have an angle greater than 30° or severe loss of air performance can result.

Do not connect the full duct size to the unit discharge collar without using a transition piece down to the size of the unit discharge collar. With metal material, the sides of the elbow and entire branch duct should be internally lined with acoustic insulation for sound attenuation.

The ductwork should be configured such that there is no line of sight between the unit discharge and the distribution diffusers.

filter rack for ducted return air application. A flexible duct collar can then be attached between a duct transition and the return air ductwork. The return air duct transition must be the same size as the return air coil face area. See **Figure 15 – Ductwork**. Be sure to allow for proper clearance to allow for filter change outs.

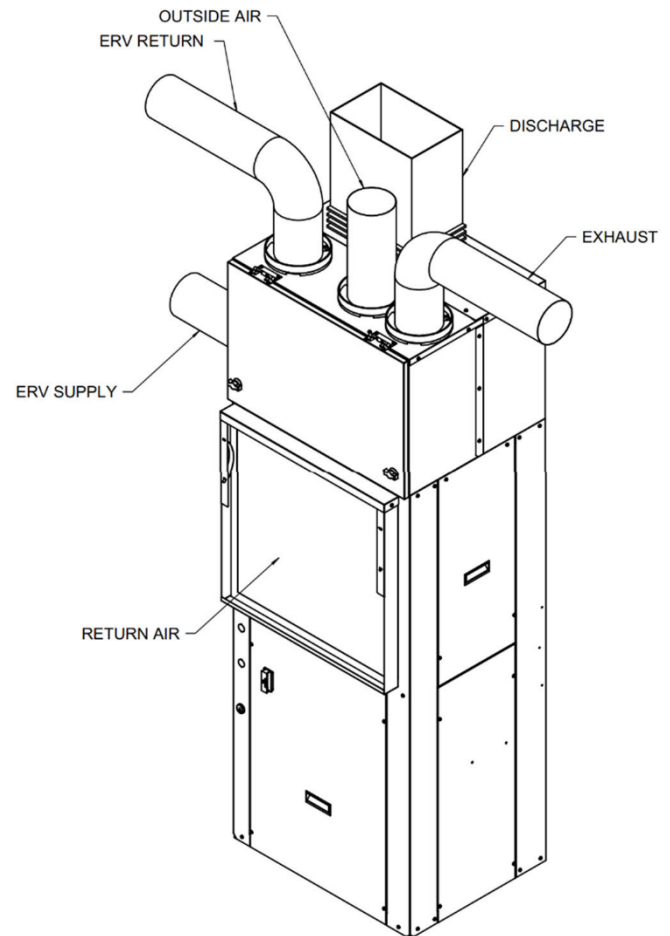

Figure 15 Ductwork

### ERV AIR DUCTING

The ERV module requires fresh/exhaust air ducted from/to outside the building and return air ducted from the occupied space. The ERV supply can be discharged into the open return of the closet. If the unit air is ducted, the ERV supply air must be ducted into the return as well for proper ventilation and filtration. For examples on ducting the ERV air flow, refer to **Fig. 16– Air flow paths**

<b>i</b>	<b>NOTE</b>	<b>i</b>
Follow the filter rack kit instructions & recommendations for installation.		

### RETURN AIR DUCTING

Return air duct can be brought in through a wall grille and then to the unit. The return duct system will normally consist of flexible connector at the unit and a trunk duct to the return air grille. With metal duct material, the return air duct should be internally lined with acoustic insulation for sound attenuation. A 2 in. [5.08 cm] air duct collar flange is included on the

# INSTALLATION (continued)

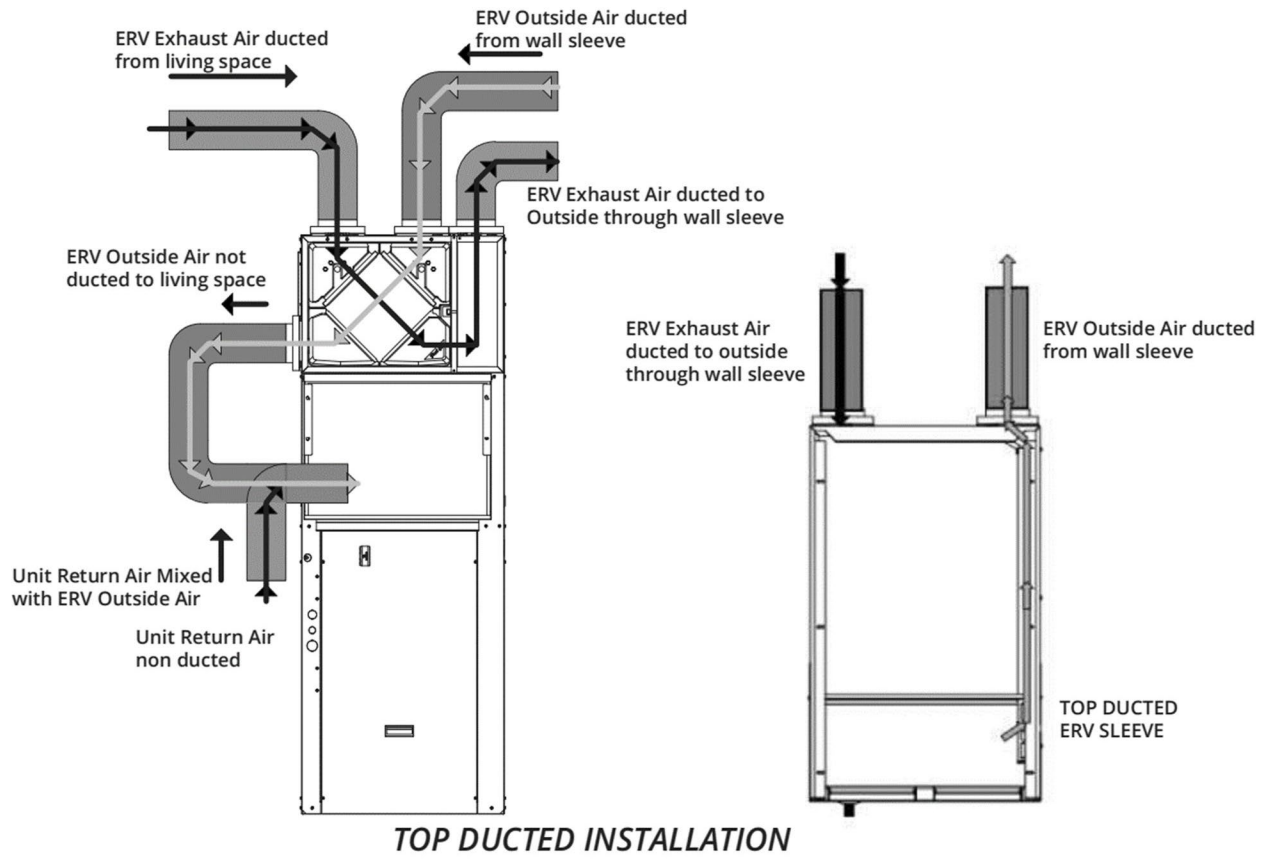

Figure 16 - ERV Airflow Paths

## INSTALLATION (continued)

### CONDENSATE DRAIN

The FRESH-PAK is designed so that the wall sleeve is the principle drain pan. Drain tubing is factory installed which drains evaporator condensate through the bottom of the unit which then is allowed to drain into the wall sleeve pan.

Condensate drain lines must be installed with adequate slope to ensure positive drainage. Prior to unit installation ensure that the drain is unobstructed and leak free.

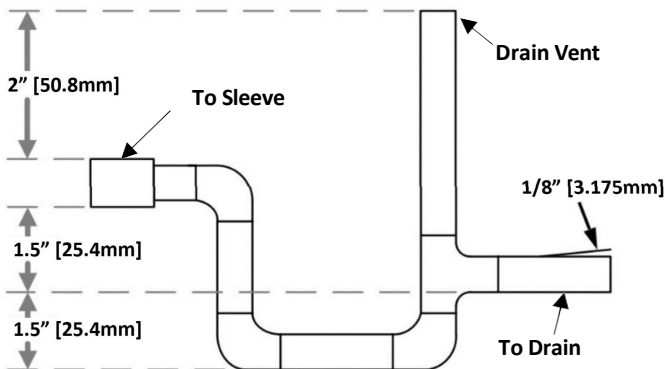
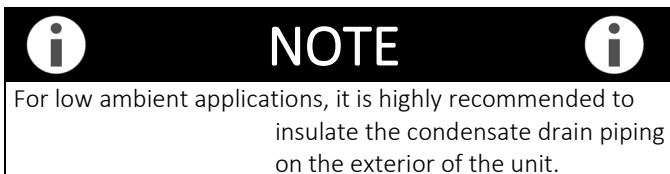
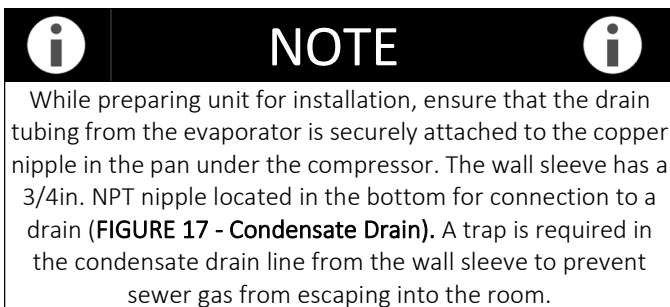

FIGURE 17 - Condensate Drain



### AIR FILTER

All indoor return air must be filtered. The preferred methods are listed below.

1. Use the factory supplied filter kit which attaches to the inlet of the evaporator.
2. Use the filter kit supplied with the access panel which accepts a 24 in. [60.96 cm] x 24 in. [60.96 cm] x 1 in. [2.54 cm] (or 2 in. [5.08 cm]) throwaway type of filter.
3. If a field installed filter rack is installed in the return air system, the filter must not be smaller than the surface area of the evaporator coil.

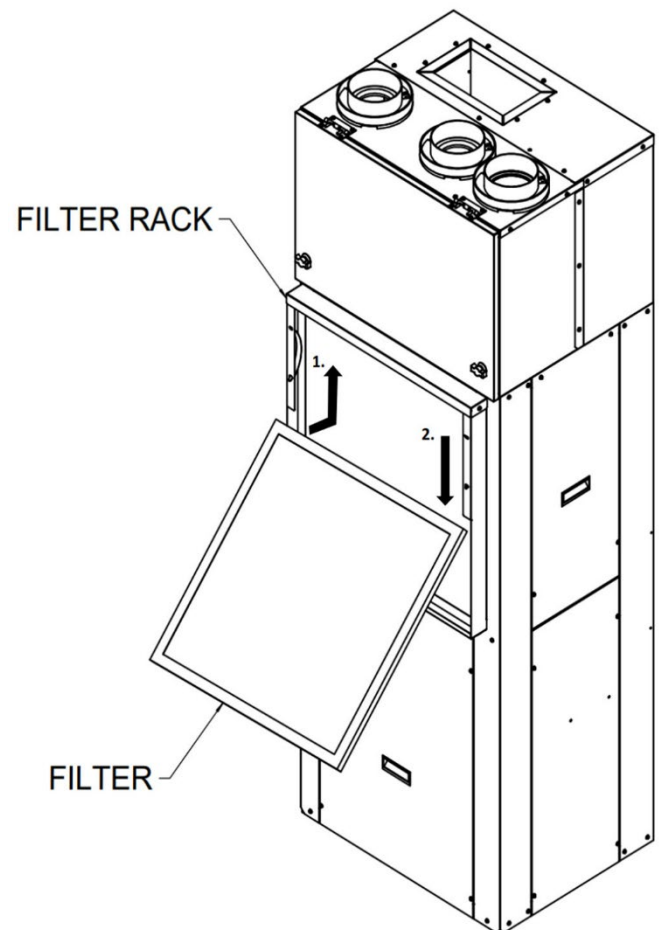

Figure 18 - Air Filter

# ELECTRICAL

## HIGH VOLTAGE

! **IMPORTANT** !

Electrical work associated with the installation of this appliance must comply with the National Electrical Code (NEC). Other local or regional electrical and building code requirements may apply.

In Canada electrical work associated with the installation of this appliance must comply with CE CSA C22

All wiring must comply with local and national code requirements. Units are provided with wiring diagrams and nameplate data to provide information required for necessary field wiring.

! **WARNING** !

⚡ **ELECTRIC SHOCK HAZARD** ⚡

Disconnect all power supplies before servicing. Lock out/tag out to prevent accidental electrical shock.

NOTE: There may be multiple power sources supplying the unit.

! **WARNING** !

Use copper conductors only. Install all parts and panels before operation of unit. Failure to follow these warnings can result in personal injury or death.

Units are provided with a class 2 transformer for 24VAC control circuits. Should any add-on accessory or component also have a class 2 transformer furnished, care must be taken to prevent interconnecting outputs of the two transformers by using a thermostat with isolating contacts.

! **WARNING** !

Connect ground wire to ground terminal marked "GND". Failure to properly ground the unit may result in personal injury or death.

! **CAUTION** !

Any device that has been furnished by the factory for field installation must be wired in strict accordance with the associated wiring diagram. Failure to properly wire the unit may damage components and void warranties.

### 208 VOLT OPERATION

All 208-240 Volt units are factory wired for 240 Volt operation. For 208 Volt operation, ; on the primary side (line voltage) of the transformer, remove the black wire from the 240 terminal and place it on the 208 terminal. See note on unit wiring diagram for instructions.

### LOW VOLTAGE

#### THERMOSTAT

Use 18 AWG wire with color-coded insulation (35°C minimum) up to 100 ft. in length (31 m). Use 16 AWG wire if more than 100 ft. of wire is required

A 24 VAC Ventilation thermostat is required to operate the FRESH-PAK unit (FIGURE 19 - Ventilation Thermostat Connections). A minimum 24 VAC Heat Pump

THERMOSTAT CONNECTIONS		
LETTER	COLOR	DESCRIPTION
C	BROWN	TRANSFORMER 24V AC COMMON
R	RED	TRANSFORMER 24V AC HOT
G	GREEN	EVAPORATOR BLOWER
U	BLUE	ERV COMFORT CALL
Y	YELLOW	COMPRESSOR CALL
Y2	GREY	COMPRESSOR 2ND STAGE
AUX	WHITE	AUXILIARY HEATING
O	ORANGE	REVERSING VALVE (ENERGIZING IN COOLING)

**Table 7 – Thermostat Connections**

Figure 19 - Ventilation Thermostat Connections

### THERMOSTAT INSTALLATION

The Thermostat should be located on an interior wall in a larger room, away from supply duct draft. Position the thermostat back plate against the wall so that it appears level and so the thermostat wires protrude through the middle of the back plate mounting holes and drill holes with a 3/16 in. bit. Install supplied anchors and secure plate to the wall. Thermostat wire must be 18 AWG wire.



# CONTROLS (continued)

## ECO SEQUENCE OF OPERATIONS - HEAT MODE

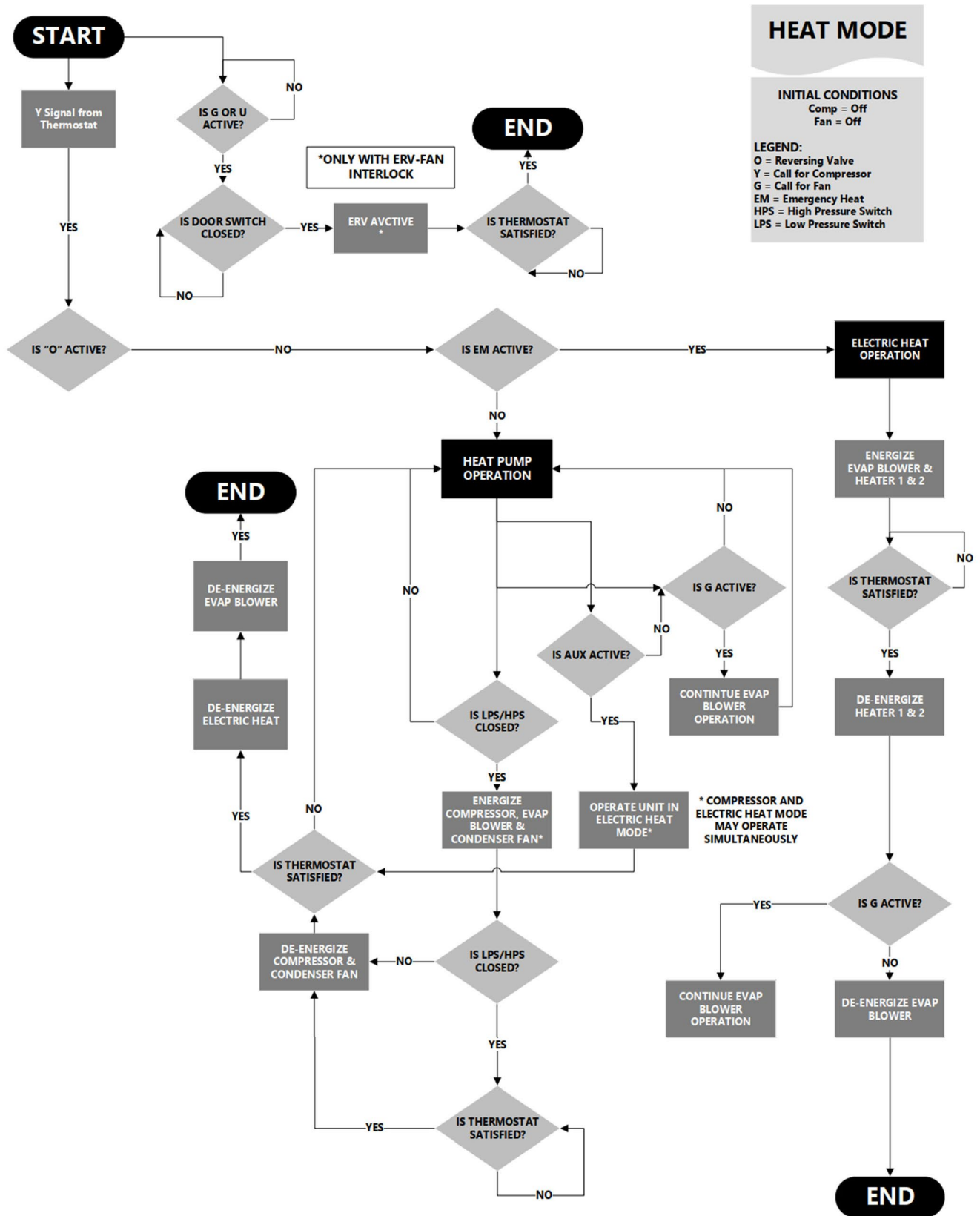

Figure 20 - ECO Sequence of Operations - Heat Mode

# CONTROLS (continued)

## ECO SERIES CONTROL MODULE

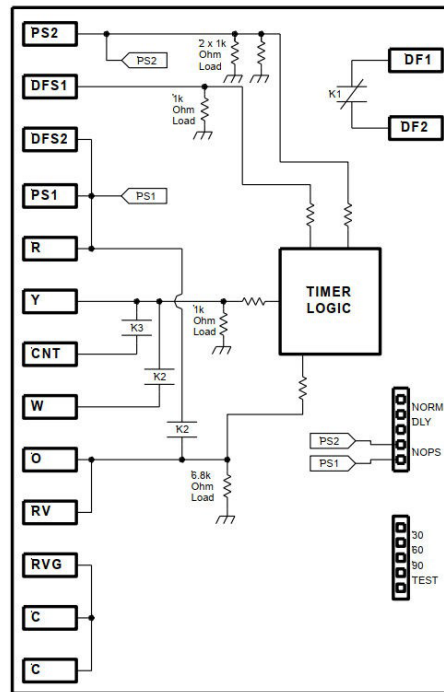

Figure 21 - ECO Series Control Module

### POWER UP

When power is first applied to the control, the board will enter a 5 minute random start delay before allowing normal operation of system outputs. The defrost timers are reset to the beginning of the interval between defrost cycles and the short cycle timer is cleared.

### FIELD TEST MODE

Test mode is recognized when the .025" pin header "TEST" pins are shorted together for more than 1 second. Test mode is exited when the short is removed from the "TEST" pins. The control automatically cancels the test mode if the "TEST" pins remain shorted together for more than 5 minutes. The test mode operates the same as normal operation except for all operations are executed at 120 times the normal speed.

### REVERSING VALVE OPERATION

The reversing valve will be energized in cooling mode in the presence of an "O" call. The reversing valve will be de-energized in heating mode in absence of the "O" call.

### ANTI-SHORT CYCLE DELAY

The anti-short cycle timer prevents the compressor from being re-started unless it has been off for at least 3 minutes. The restart delay timer is activated on power-up and whenever the compressor is turned off. If the thermostat calls for compressor ("Y" energized) before the timer has expired, the control keeps the compressor off until the timer expires. If the thermostat calls for compressor ("Y" energized) on after the timer has expired, the control immediately turns on the compressor.

### POWER INTERRUPTIONS

If the power to the control is interrupted for less than 20 milliseconds, the control shall resume operation at the same point in the timing cycle. The control shall not change modes of operation due to a power interruption of less than 20 milliseconds. Relays may temporarily drop out during the power interruption. Power interruptions over 20 to 50 milliseconds are to reset the short cycle timer. If the compressor was energized, it de-energizes for the short cycle time period. Defrost timing is not to be affected below 100mS.

## CONTROLS (continued)

### COOLING OPERATION

#### STEADY STATE COOLING

If the control recognizes cooling mode ("Y" and "O" energized), the reversing valve energizes when the thermostat energizes the "O" terminal through the physical connection of the control, and the compressor will energize after the short cycle period. The reversing valve is immediately de-energized when "O" is deenergized (unless in defrost).

The control ignores the defrost sensor and keeps the defrost interval timers cleared while "O" is energized. The control ignores the pressure switch input for the first 3 minutes after the compressor is energized

### HEATING OPERATION

#### FIRST STAGE HEATING

The control recognizes heating mode when a call for heat is made ("Y" input is energized). When the 3 minute short cycle time has been satisfied, the control energizes the compressor. The control ignores the pressure switch input for the first 3 minutes after the compressor is energized.

#### INTERVAL BETWEEN DEFROSTS

When the defrost switch is open or the thermostat is in cooling mode ("O" energized) the defrost interval timers remain reset at zero and the control is not in defrost. If the defrost switch opens or the thermostat has a call for cool mode before a defrost cycle initiates, the defrost interval timer is cleared.

When the defrost switch is closed and the thermostat "O" is de-energized, a timer on the control accumulates compressor run time. When the compressor run time reaches the selected defrost interval time (30, 60, or 90 minutes), the control places the heat pump in defrost.

The "Y" input may cycle on and off during the accumulation time without resetting the accumulation timer.

If the shorting jumper that selects the defrost interval time is not present, a default of 90 minutes will be selected

#### DEFROST CYCLE

While in defrost, the control de-energizes the outdoor fan, energizes the reversing valve and auxiliary heat outputs. A timer on the control accumulates defrost compressor run time.

If the indoor thermostat is satisfied ("Y" de-energizes), the compressor, reversing valve, and auxiliary heat de-energize and the fan re-energizes, suspending the defrost mode until the compressor is re-energized.

When the compressor is re-energized, the defrost mode is resumed at the same point, unless the defrost switch

has opened, or the thermostat "O" has been energized. The control ignores the pressure switch input for the first 3 minutes of defrost. If the control has been in defrost past the initial 3 minutes, and the pressure switch opens, the compressor, reversing valve, and auxiliary heat de-energize and the fan re-energizes. The short cycle timer resets and the defrost timer holds the value of defrost time. After the pressure switch re-closes and the short cycle period is over, the control will re-energize the compressor, reversing valve, and auxiliary heat and de-energize the fan. The control will then continue to run the defrost mode from the time left on the defrost timer.

If compressor delay ("DLY") operation is selected, when the defrost mode is initiated, the compressor is de-energized for 10 seconds starting when the reversing valve and auxiliary heat are energized.

#### DEFROST TERMINATION

The control terminates defrost when the defrost switch opens or the control finishes the 10 minutes of defrost time. The control immediately de-energizes the auxiliary heat, the reversing valve, and energizes the outdoor fan. The control resets the defrost interval timer. The compressor may still run depending upon the current call from the thermostat.

The control ignores the pressure switch input for the first 3 minutes after defrost is terminated.

If compressor delay ("DLY") operation is selected, when the defrost mode is terminated, the compressor is de-energized for 10 seconds starting when the reversing valve and auxiliary heat are de-energized input

## CONTROLS (continued)

---

### CONTINUOUS FAN OPERATION

If no other thermostat inputs are present, the low-speed evaporator fan output will be energized when the “G” thermostat input is active. If either of the “Y”, “AUX” OR “E” inputs are present, the operation of the evaporator fan will be based upon those inputs, and the “G” thermostat input will be ignored. In the case of the “E” input interrupting the compressor operation, the emergency heat will continue to operate until the thermostat is no longer calling for heat.

### AUXILIARY HEATING OPERATION

#### THERMOSTAT CALL FOR AUXILIARY HEAT

Depending on the thermostat control, the thermostat may energize both “Y” and “AUX” during low ambient heat operation to provide additional system heat. During this time both the compressor and electric heat will operate together and the system will energize the high fan speed.

### A2L SENSING AND MITIGATION

Units charged with over 4lbs (1.81kg) of R454B refrigerant are shipped with a factory installed refrigerant leak detector attached to the evaporator coil. In the event that a refrigerant leak is detected, the controls will disable the compressor operation, and energize the evaporator fan to disperse the leaked refrigerant. The unit will operate in this mitigation state until the sensor no longer detects a refrigerant leak, for a minimum time of 5 minutes. Once the mitigation period has ended, the unit will return to its normal operation based on the current thermostat inputs. An LED status light is provided with the sensor for diagnostic purposes, the description of the LED status light signals can be found in the troubleshooting section.

# CONTROLS (continued)

## ERV CONTROL MODULE (OPTIONAL)

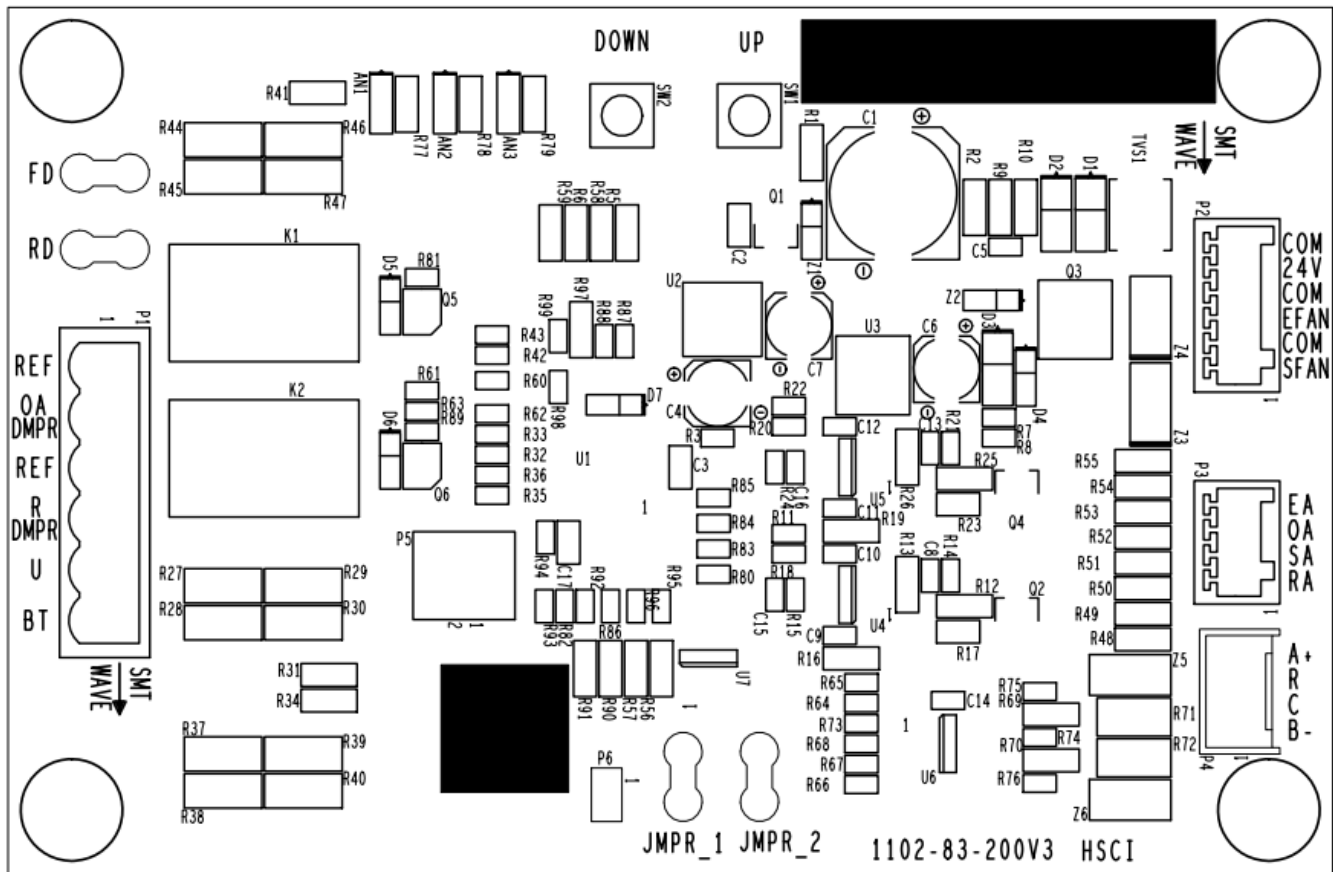

Figure 22 ERV Control Module

### NORMAL OPERATION MODES

#### Standby Mode:

All control outputs are off and the control is waiting for a thermostat demand or thermistor threshold. The thermostat and thermistor inputs are continually monitored. The control initiates action when a thermostat call is received or when a thermistor threshold is reached.

When there is no demand from the thermostat or thermistors for defrost, or fan operation, the control shall be considered to be in Standby Mode. In this mode, it shall de-energize all outputs and flash the “heartbeat” status code on the STATUS LED until action is initiated by a thermostat call. In Standby, it shall continually monitor all thermostat and thermistor inputs.

When the control is not in standby mode, the mode priority shall be as shown Table 5

## CONTROLS (continued)

PRIORITY	MODE
1	Front Desk Shutdown
2	Coil Freeze Protection
3	Heating Mode
4	Fan Boost Mode
5	Fan Only Mode (“U”)
6	Continuous Fan Operation

**Table 8 - ERV Control Module Mode Priority**

### Front Desk Shutdown Mode:

If the front desk disconnects “FD” from “R”, the control enters Front Desk Shutdown. The Control immediately de-energizes S FAN, E FAN, and R DMPR. After 10 seconds, the control de-energizes OA DMPR. The control shall resume normal operation when “R” is re-applied to “FD”. The control comes with a factory-installed jumper that must be removed if the use of a “Front Desk Switch” is required in the installation.

### Coil Freeze Protection Mode:

If the TSA thermistor falls below 35° then the control will go into a Coil Protection lockout. The S Fan and E Fan are de-energized, and the OA damper is closed. During this time, the RED, and GREEN LED’s are flashing and the YELLOW LED is ON . After 30 minutes, the OA damper will open, and the S Fan and E Fan are re-energized to the user-defined set point.

### Heating Modes:

The heating modes, First Defrost, Second Defrost, and Third Defrost are designed to reduce frost accumulation during the normal operation based on the temperature of the Fresh Outside Air entering the ERV module. This is done using one of two methods:

- If the P6 connection has a shunt populated, the unit is intended to be paired with a field installed in line duct heater to raise the temperature of the incoming air above a minimum threshold. Selection of the pre-heating device should be considered based on the CFM requirements and minimum design temperature of outdoor air temperature.

- If the P6 connection is not populated, the unit is intended to be paired with a field installed recirculation damper controlled by the board. The board supports a 24V Normally closed damper that is energized during the defrosting modes. Special care shall be made in the installation of the recirculation damper so that the ducting does not recirculate Class II air with Class I air as per ASHRAE 62.1 and 62.2

In all defrost modes, the “use defined set point” refers to the current operating mode set point when the unit enters the defrost mode.

- **First Defrost Mode** - The control goes into First Defrost Mode if the TOA thermistor falls below 30°F(1.7°C) but stays above 10°F(-6.7°C).

If P6 has a shunt populated\*, S Fan and E Fan speeds are reduced by 10% of the current user defined set point for each fan. After 3 minutes, or if the TOA thermistor raises above 40°F, the S Fan and E Fan speeds are returned to the user defined set point, and the control enters a 25 minute defrost lockout. The yellow LED is flashing.

If P6 Shunt does not have the shunt populated, R DMPR is energized and S FAN and E FAN are energized at the user defined set point. The yellow LED is flashing. After 3 minutes, the control de-energizes the R DMPR and enters a 25 minute defrost lockout

If the TOA thermistor falls below 10°F before the control leaves First Defrost Mode, then the control will enter the Second Defrost Mode.

## CONTROLS (continued)

- Second Defrost Mode** - The control goes into Second Defrost Mode if the TOA thermistor falls below 10°F but stays above -10°F. If P6 has a shunt populated\*, S Fan and E Fan speeds are reduced by 30% of the current user defined set point for each fan. After 5 minutes, the S Fan and E Fan speeds are returned to the user defined set point, and the control enters a 17 minute defrost lockout. The yellow LED is solid. If P6 does not have a shunt populated, R DMPR is energized and S FAN and E FAN are energized at the user defined set point. The yellow LED is Solid. After 5 minutes, the control de-energizes the R DMPR and enters a 17 minute defrost lockout. If the TOA thermistor falls below -10°F before the control leaves Second Defrost Mode, then the control will enter Third Defrost Mode.

- Third Defrost Mode** - The control goes into Third Defrost Mode if the TOA thermistor falls below -10°F. If P6 has a shunt populated\*, S Fan and E Fan speeds are reduced by 50% of the current user defined set point for each fan. After 7 minutes, the S Fan and E Fan speeds are returned to the user-defined set point, and the control enters a 15 minute defrost lockout. The yellow and green LEDs are solid. If P6 does not have a shunt populated, R DMPR is energized and S FAN and E FAN are energized at the user defined set point. After 7 minutes, the control de-energizes the R DMPR and enters a 15 minute defrost lockout. The yellow and green LEDs are Solid.



### NOTE



P6 is a terminal that determines if R DMPR is present. If a shunt is present, then the R DMPR is not connected. If no shunt is present, then R DMPR is connected.

#### Fan Boost Mode:

The thermostat calls for fan boost by connecting “BT” to “R”. The control energizes the OADMPR. After 10 seconds, the S FAN and E FAN are energized to the fan boost speed set point.

The Fan Boost Mode set point can be adjusted as detailed in the balancing mode section; the factory default is 100%.

#### Fan Only Mode:

The thermostat calls for fan by connecting “U” to “R”. The OA DMPR is energized immediately. After 10 seconds, the S FAN and E FAN are ran at the user-defined set point for normal operation.

The Fan Only Mode set point can be adjusted as detailed in the balancing mode section. The factory default is 50%.

#### Continuous Fan Operation:

When the JMPR terminals have been connected, and the control is in no other mode, the control enters continuous fan mode. OA DMPR is energized immediately. After 10 seconds, the S FAN and E FAN are ran at the Continuous Fan Operation set point. If the installation does not require Continuous Fan Operation, the installer must remove the factory installed jumper wire.

The Continuous Fan Operation set point can be adjusted as detailed in the balancing mode section, the factory default is 30%.

#### Control Lockout Modes:

Some operating conditions may cause the controller to enter a lockout period in order to protect the functionality of the ERV module.

- Defrost Lockout** - When in Defrost Lockout, the control cannot enter any of the defrost modes. All other modes may be accessed. Lockout ends when the specified time elapses in the defrost modes.

- Thermistor Lockout** - In the event of a thermistor failure where the thermistor is open or shorted, the control enters a Thermistor Lockout. All outputs are de-energized and no other modes shall be accessed. After 30 minutes, the control resumes normal operation. If the error occurs 3 times within a 2-hour period, the control will enter the Thermistor Lockout Mode indefinitely, and will require maintenance.

## CONTROLS (continued)

### Balancing Mode:

To adjust the fan speed of the Supply and Exhaust fans simultaneously.

- Press the UP/DOWN button to increase/decrease the fan speed set point of both fans by 10% for each time the button is pressed (from 10%-100%) The red LED flashes with each button press.
- When both buttons are pressed simultaneously for 5 seconds, the yellow LED will be solid, the green LED will flash a number of times equal to the SUPPLY FAN speed set point, then the red LED will flash a number of times equal to the EXHAUST FAN speed set point.

To individually adjust the fan speeds:

- Depress the UP button for 5 seconds to enter Supply Fan Adjustment mode. The red LED is solid, and the green LED is flashing. In this mode, pressing the UP/DOWN button will only adjust the SUPPLY FAN speed set point by 10% for each time the button is pressed. The yellow LED will flash a number of times equal to the new Supply Fan speed set point (1-10). To exit this mode, depress the UP button for 5 seconds to return to standard control operation.
- Depress the DOWN button for 5 seconds to enter Exhaust Fan Adjustment mode. The green LED is solid, and the red LED is flashing. In this mode, pressing the UP/DOWN button will only adjust the EXHAUST FAN speed set point by 10% for each time the button is pressed. The yellow LED will flash a number of times equal to the new Exhaust Fan speed set point (1-10). To exit this mode, depress the DOWN button for 5 seconds to return to standard control operation.

The Fan speed set point is only adjusted for the mode the control is currently in. Adjusting the fan speed during Fan Only Mode will not adjust the fan speed in Continuous Fan Operation or Fan Boost Mode.

The ERV Control features three LEDs located next to the UP/DOWN push buttons to indicate the controllers current operating mode. The LED mode behavior can be found in **Table 8**

Mode/Function	LED Color		
	Red	Yellow	Green
Standby Mode	Flashing (Heartbeat)*	Off	Off
Continuous Fan Operation	Off	Off	Flashing**
Coil Freeze Protection	Flashing**	Solid	Flashing**
Fan Only Mode ("U")	Off	Off	Solid
First Defrost	Off	Flashing**	Off
Second Defrost	Off	Solid	Off
Third Defrost	Off	Solid	Solid
Front Desk Switch	Solid	Off	Off
Fan Boost Mode	Off	Flashing (alternate)***	Flashing (alternate)***
TOA Thermistor Lockout	Flashing (alternate)***	Off	Flashing (alternate)***
TSA Thermistor Lockout	Flashing (alternate)***	Solid	Flashing (alternate)***
Balancing Mode-E FAN	Off	Flashing (1-10)**	Solid
Balancing Mode-S FAN	Solid	Flashing (1-10)**	Off
Fan Speed Check	Flashing: 1-10 (E Fan Speed)	Solid	Flashing: 1-10 (S Fan Speed)

**Table 9 - LED Mode Behavior**

Note\*: Heartbeat flashing shall be 1 second on followed by 1 second off.

Note\*\*: A single LED flashing shall be ½ second on followed by ½ second off.

Note\*\*\*: For alternate flashing LED's, each LED shall be on for ½ second and off for ½ second. An LED will only be on if the other is off.

# CONTROLS (continued)

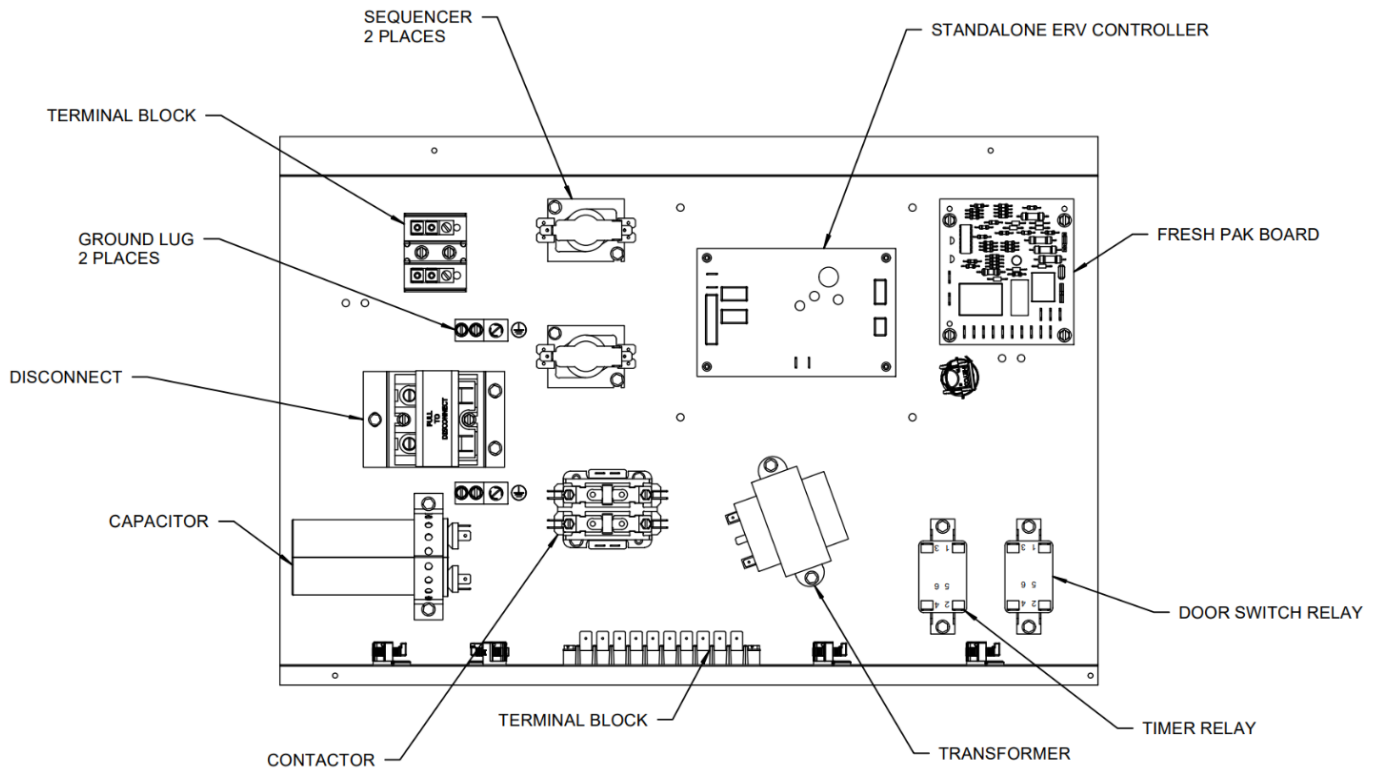

Figure 23 - Control Box

FRESH-PAK units are equipped with a direct drive ECM blower motor. See the BLOWER DATA section for airflow at different external static pressure. Select the motor speed according to the airflow and external static pressure. See wiring diagram located on unit.

For FRESH-PAK models, the default motor tap selections can be changed by directly changing the speed tap at the motor terminal.

**IMPORTANT**

The unit is designed to operate at maximum 0.5 in.w.c external static pressure. Operation at higher E.S.P may cause equipment failure. For applications requiring higher static operation, please contact factory or the manufacture’s sales representative.

**WARNING/AVERTISSEMENT**

**ELECTRIC SHOCK HAZARD**

High efficiency brushless DC motors are wired with power applied at all times, see illustration above.  
Low voltage thermostat demand and board algorithms will control its use.

# DEFROST DUCTING CONSIDERATIONS

Units with the ERV option may require additional ducting considerations for the fresh air supply and return air supply. The ERV module comes with two options for integrated defrost controls; **Pre-heat defrost** in tandem with a field installed pre-heating device, or **recirculation defrost** combined with a field installed recirculation damper controlled by the unit’s control module.

## Pre-heat Defrost

When using a in line duct heater to prevent frost accumulation, special care should be taken to select the proper sized heater dependent on the design temperature for outdoor air and the CFM requirements. **Table 9** can be used to determine the proper sizing of the pre-heater, ensuring that the design temperature conditions do not bring the entering Air Temperature (EAT) below 30°F (-1°C). When the controller detects the Outside Air Temperature is below the threshold it will automatically reduce the fan speed of the Fresh Air intake and Return Air streams, so as not to bring the occupied space into a negative pressure, increasing the temperature of incoming air to prevent the buildup of frost on the ERV CORE. An example of ductwork with the pre-heating device can be seen in **Figure 16**.

		FRESH AIR CFM														
KW	EAT (°F)	30	35	40	45	50	55	60	65	70	75	80	85	90	95	100
1	-10	95.3	80.3	69.0	60.2	53.2	47.5	42.7	38.6	35.1	32.1	29.5	27.2	25.1	23.3	21.6
	-20	85.3	70.3	59.0	50.2	43.2	37.5	32.7	28.6	25.1	22.1	19.5	17.2	15.1	13.3	11.6
	-30	75.3	60.3	49.0	40.2	33.2	27.5	22.7	18.6	15.1	12.1	9.5	7.2	5.1	3.3	1.6
	-40	65.3	50.3	39.0	30.2	23.2	17.5	12.7	8.6	5.1	2.1	-0.5	-2.8	-4.9	-6.7	-8.4
1.5	-10	148.0	125.4	108.5	95.3	84.8	76.2	69.0	62.9	57.7	53.2	49.3	45.8	42.7	39.9	37.4
	-20	138.0	115.4	98.5	85.3	74.8	66.2	59.0	52.9	47.7	43.2	39.3	35.8	32.7	29.9	27.4
	-30	128.0	105.4	88.5	75.3	64.8	56.2	49.0	42.9	37.7	33.2	29.3	25.8	22.7	19.9	17.4
	-40	118.0	95.4	78.5	65.3	54.8	46.2	39.0	32.9	27.7	23.2	19.3	15.8	12.7	9.9	7.4
2	-10	200.7	170.6	148.0	130.4	116.4	104.9	95.3	87.2	80.3	74.3	69.0	64.4	60.2	56.5	53.2
	-20	190.7	160.6	138.0	120.4	106.4	94.9	85.3	77.2	70.3	64.3	59.0	54.4	50.2	46.5	43.2
	-30	180.7	150.6	128.0	110.4	96.4	84.9	75.3	67.2	60.3	54.3	49.0	44.4	40.2	36.5	33.2
	-40	170.7	140.6	118.0	100.4	86.4	74.9	65.3	57.2	50.3	44.3	39.0	34.4	30.2	26.5	23.2
3	-10	306.0	260.9	227.0	200.7	179.6	162.4	148.0	135.8	125.4	116.4	108.5	101.5	95.3	89.8	84.8
	-20	296.0	250.9	217.0	190.7	169.6	152.4	138.0	125.8	115.4	106.4	98.5	91.5	85.3	79.8	74.8
	-30	286.0	240.9	207.0	180.7	159.6	142.4	128.0	115.8	105.4	96.4	88.5	81.5	75.3	69.8	64.8
	-40	276.0	230.9	197.0	170.7	149.6	132.4	118.0	105.8	95.4	86.4	78.5	71.5	65.3	59.8	54.8
	-50	266.0	220.9	187.0	160.7	139.6	122.4	108.0	95.8	85.4	76.4	68.5	61.5	55.3	49.8	44.8

TABLE 10 – FRESH AIR CFM

# DEFROST DUCTING CONSIDERATIONS

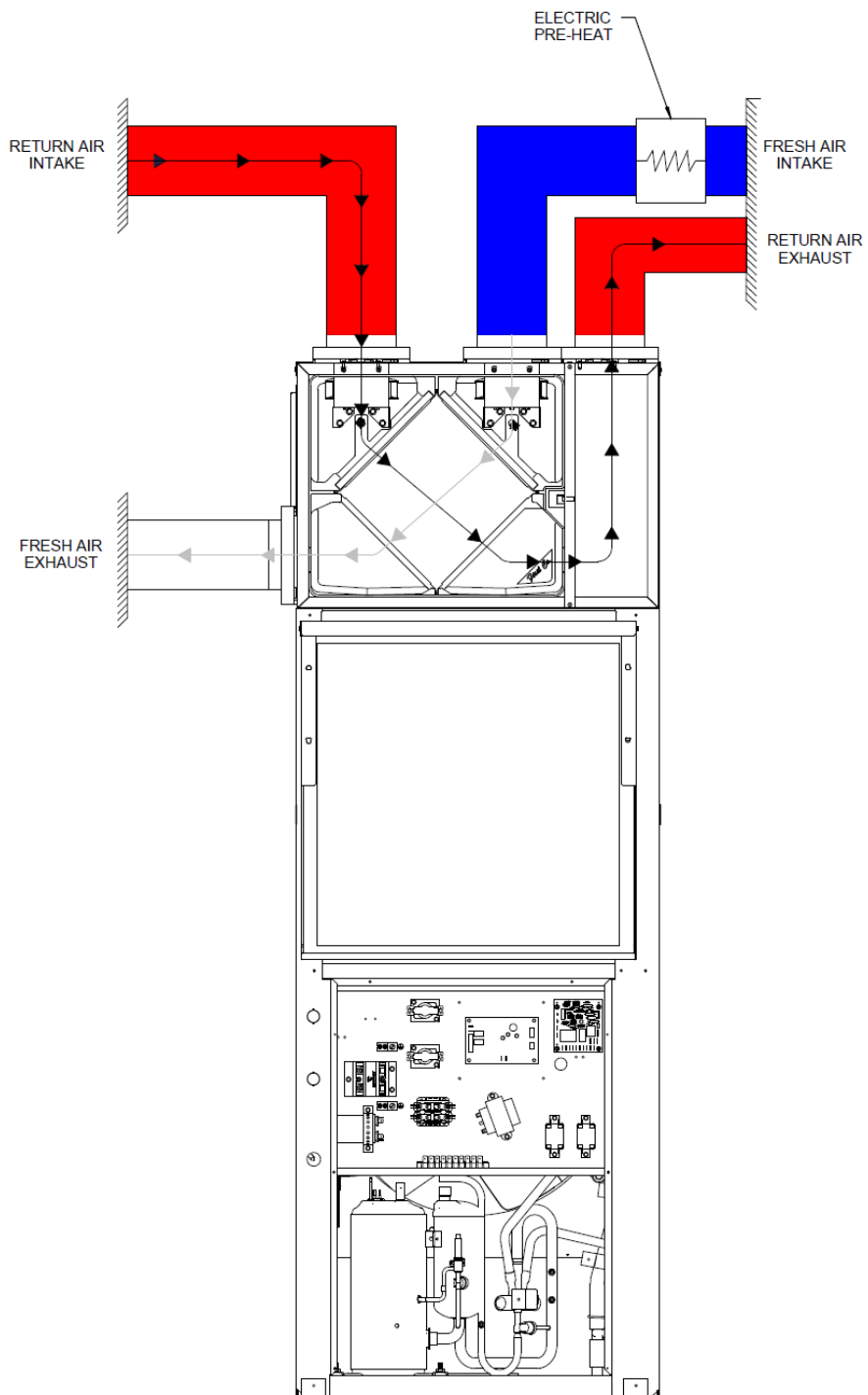

Figure 24 - Defrost Ducting

## DEFROST DUCTING CONSIDERATIONS

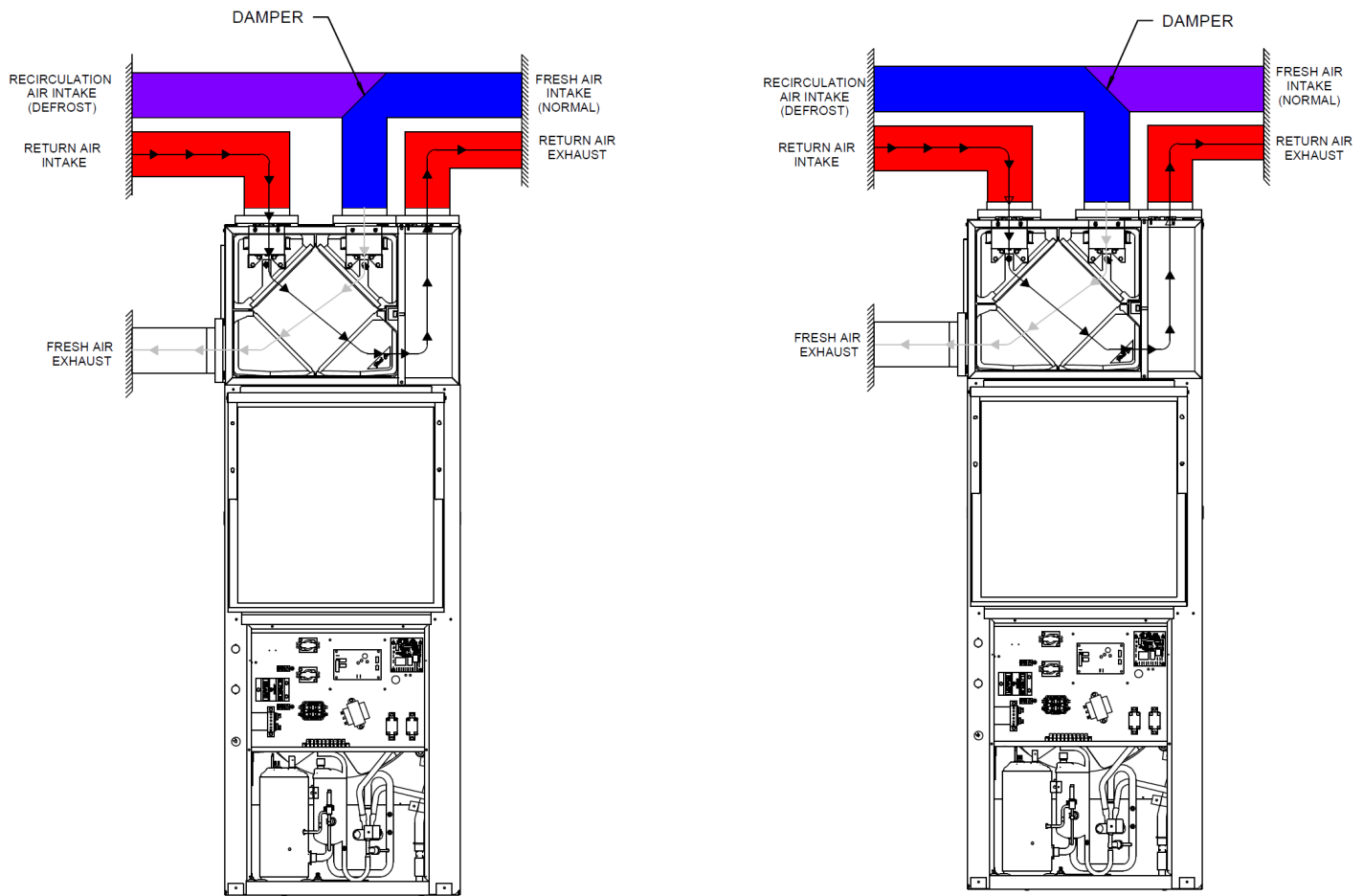

Figure 25 - Recirculation Defrost

### Recirculation Defrost

For Installations without pre-heating devices, a recirculation damper can be installed that allows the recirculation of air from the occupied space into the Fresh Air supply of the ERV. Special care should be taken to ensure that class II air is not recirculated with Class I air in installations where the ERV return is ducted from areas such as a kitchen fan hood or bathroom fan. To control the recirculation damper, the installer must remove the shunt connection the P6 terminal (see **figure 9**) to allow the controller to recognize the presence of a recirculation damper in the system. An example of a typical installation for the recirculation defrost can be seen in **Figure 13 and 14**.



## NOTE



When using recirculation defrost, special care should be taken to ensure that the recirculation duct is not connected to a bathroom fan, kitchen hood or other source of air that does not meet the requirements for Class I air per ASHRAE 62.1 and 62.2.

# BLOWER DATA

BLOWER DATA												
MODEL	Motor Tap	Motor Speed	IWC STATIC PRESSURE									
			0.10		0.20		0.30		0.40		0.50	
			SCFM	W	SCFM	W	SCFM	W	SCFM	W	SCFM	W
EPE12203	1	T1	284	22	271	30	255	36	237	41	219	45
	2	T2H	446	73	433	81	417	87	399	41	381	95
	3	T3	505	98	492	106	476	112	458	41	440	121
	4	T4C	477	86	464	93	448	100	430	41	412	108
EPE12205	1	T1	284	22	271	30	255	36	237	41	219	45
	2	T2H	477	86	464	93	448	100	430	41	412	108
	3	T3	505	98	492	106	476	112	458	41	440	121
	4	T4C	477	86	464	93	448	100	430	41	412	108
EPE182205	1	T1	540	74	500	75	474	77	441	77	407	74
	2	T2H	703	126	663	126	637	129	604	129	570	126
	3	T3	832	189	792	189	766	191	734	191	700	189
	4	T4C	749	146	709	146	683	149	651	149	617	146
	5	T5	901	233	861	234	835	236	803	236	769	233
EPE182207	1	T1	540	74	500	75	474	77	441	77	407	74
	2	T2H	749	146	709	146	683	149	651	149	617	146
	3	T3	792	167	752	167	726	170	694	170	660	167
	4	T4C	832	189	792	189	766	191	734	191	700	189
	5	T5	901	233	861	234	835	236	803	236	769	233
EPE182210	1	T1	407	46	367	46	341	48	308	48	274	46
	2	T2H	792	167	752	167	726	170	694	170	660	167
	3	T3	956	274	916	275	890	277	857	277	823	275
	4	T4C	832	189	792	189	766	191	734	191	700	189
	5	T5	901	233	861	234	835	236	803	236	769	233
EPE24205	1	T1	749	146	709	146	683	149	651	149	617	146
	2	T2H	832	189	792	189	766	191	734	191	700	189
	3	T3	956	274	916	275	890	277	857	277	823	275
	4	T4CL	663	111	623	111	597	114	564	114	530	111
	5	T5CH	907	237	867	238	841	240	809	240	775	238
EPE24207	1	T1	749	146	709	146	683	149	651	149	617	146
	2	T2H	868	211	828	211	802	214	770	214	736	211
	3	T3	832	189	792	189	766	191	734	191	700	189
	4	T4CL	663	111	623	111	597	114	564	114	530	111
	5	T5CH	907	237	867	238	841	240	809	240	775	238
EPE24210	1	T1	749	146	709	146	683	149	651	149	617	146
	2	T2H	907	237	867	238	841	240	809	240	775	238
	3	T3	832	189	792	189	766	191	734	191	700	189
	4	T4CL	663	111	623	111	597	114	564	114	530	111
	5	T5CH	931	255	891	255	865	257	832	257	798	255

TABLE 11 – Blower Data

<sup>c</sup> Factory Default Cooling and Heat Pump Airflow

<sup>h</sup> Factory Default Electric Heat Airflow

T2 & T3 are reserved for electric heat operation only

T4 & T5 are reserved for cooling and heat pump operation only

Blower performance data based on a dry coil at 70°F DB EAT with a standard 1" clean air filter

## BLOWER DATA (continued)

BLOWER DATA												
MODEL	Motor Tap	Motor Speed	IWC STATIC PRESSURE									
			0.10		0.20		0.30		0.40		0.50	
			SCFM	W	SCFM	W	SCFM	W	SCFM	W	SCFM	W
EPE24205	1	T1	749	146	709	146	683	149	651	149	617	146
	2	T2H	832	189	792	189	766	191	734	191	700	189
	3	T3	956	274	916	275	890	277	857	277	823	275
	4	T4CL	663	111	623	111	597	114	564	114	530	111
	5	T5CH	907	237	867	238	841	240	809	240	775	238
EPE24207	1	T1	749	146	709	146	683	149	651	149	617	146
	2	T2H	868	211	828	211	802	214	770	214	736	211
	3	T3	832	189	792	189	766	191	734	191	700	189
	4	T4CL	663	111	623	111	597	114	564	114	530	111
	5	T5CH	907	237	867	238	841	240	809	240	775	238
EPE24210	1	T1	749	146	709	146	683	149	651	149	617	146
	2	T2H	907	237	867	238	841	240	809	240	775	238
	3	T3	832	189	792	189	766	191	734	191	700	189
	4	T4CL	663	111	623	111	597	114	564	114	530	111
	5	T5CH	931	255	891	255	865	257	832	257	798	255
EPE30205	1	T1	729	117	656	117	615	111	584	106	541	96
	2	T2H	873	215	843	215	802	209	771	204	728	194
	3	T3	961	274	931	273	891	267	860	262	816	252
	4	T4CL	981	287	950	287	910	281	879	276	836	266
	5	T5CH	1014	310	984	310	943	304	912	299	869	289
EPE30207	1	T1	729	117	656	117	615	111	584	106	541	96
	2	T2H	922	247	891	246	851	240	820	235	776	226
	3	T3	961	274	931	273	891	267	860	262	816	252
	4	T4CL	981	287	950	287	910	281	879	276	836	266
	5	T5CH	1014	310	984	310	943	304	912	299	869	289
EPE30210	1	T1	791	141	710	141	670	135	639	130	595	120
	2	T2H	992	295	962	295	921	289	890	284	847	274
	3	T3	961	274	931	273	891	267	860	262	816	252
	4	T4CL	981	287	950	287	910	281	879	276	836	266
	5	T5CH	1014	310	984	310	943	304	912	299	869	289

TABLE 12 – Blower Data

<sup>c</sup> Factory Default Cooling and Heat Pump Airflow

<sup>h</sup> Factory Default Electric Heat Airflow

T2 & T3 are reserved for electric heat operation only

T4 & T5 are reserved for cooling and heat pump operation only

Blower performance data based on a dry coil at 70°F DB EAT with a standard 1" clean air filter

# FIELD ERV ACCESSORIES

## INSTALLATION

!
IMPORTANT
!

Installation must be Manufacturer Approved.

### OUTSIDE AIR DAMPER

The FRESH-PAK ERV control allows for the addition of a motorized outside air damper. This is to help prevent any back draft air from entering the space while the ERV is not operating.

i
NOTE
i

Damper must be 24V and normally closed.

1. Power down FRESH-PAK unit.
2. Attach 24V lead to OA DMPR connection on P1 terminal (See **FIGURE 26 - Outside Air Damper Connection**) on the ERV control board.
3. Connect the Com lead of the damper to a chassis ground of the FRESH-PAK unit.
4. Power on the FRESH-PAK unit.
5. Once the ERV restarts (Less than a minute delay), verify that the damper opens.

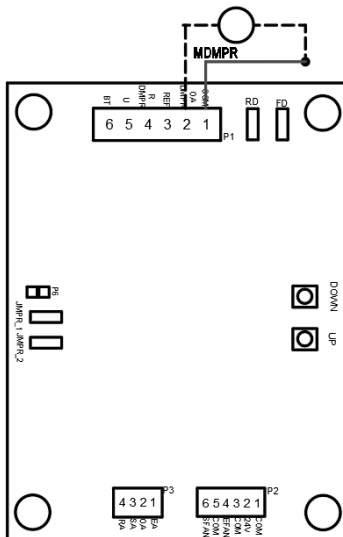

FIGURE 26 - Outside Air Damper Connection

### BOOST TIMER

The FRESH-PAK ERV controller has the flexibility to work with many different wall mounted boost timers (egg timer). For typical analog (rotary style) timers follow Version 1 installation method. For digital (120V wall style) follow Version 2 installation.

### VERSION 1 (ANALOG)

1. Power down FRESH-PAK unit.
2. Find the 120V relay in the FRESH-PAK control box. Refer to the applicable wiring diagram. Remove the 24V leads from the relay.
3. Connect the 24V Red REF wire from Pin 3 of P1 terminal of the ERV controller to the LINE side of your timer switch.
4. Connect the LOAD side of the timer switch to the BT terminal wire on the P1 terminal of the ERV Controller [See **FIGURE 27 - Version 1 (Egg Timer/Analog Connection)**].
5. Reenergize the FRESH-PAK unit.
6. Once the ERV restarts (less than a minute) activate the timer and confirm the ERV fans go to high speed "Boost Mode".

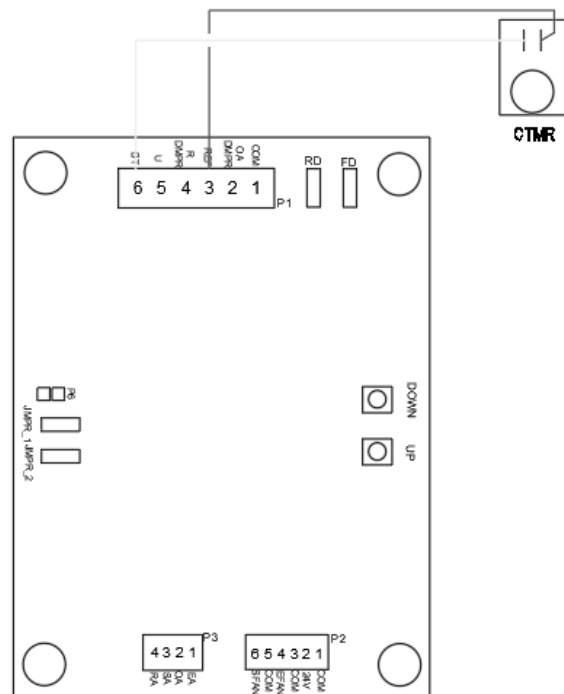

FIGURE 27 - Version 1 (Egg Timer/Analog Connection)

# FIELD ERV ACCESSORIES (continued)

## VERSION 2 (DIGITAL)

1. Power down FRESH-PAK unit.
2. Refer to the Installation instructions provided with the 120V digital timer switch. The switch will require its own 120v power source.
3. Find the 120V relay in the FRESH-PAK control box. Refer to the applicable wiring diagram.
4. Connect the R connection of the timer switch to the 120V pole on the relay.
5. Connect the NEUTRAL side of the timer switch to the remaining pole on the 120V relay (
6. **FIGURE 28 - Version 2 (120V Digital Timer Connection).**
7. Reenergize the FRESH-PAK unit.
8. Once the ERV restarts (less than a minute) activate the timer and confirm the ERV fans go

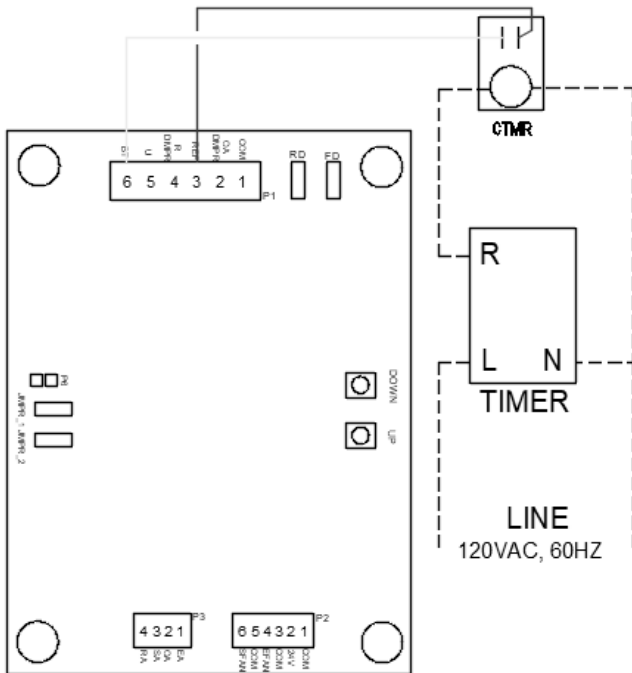

FIGURE 28 - Version 2 (120V Digital Timer Connection)

## CO2/Humidity Sensor

1. Power down FRESH-PAK unit.
2. Refer to the Installation instructions provided with the 24V Sensor.
3. For sensors with 0-10V PWM fan control use connection A shown in **Figure 29 – Humidity/CO2 Sensor**. For 24V relay activation of fans use the B connections. Insert sensor wires into specified terminals. **DO NOT REMOVE ANY EXISTING WIRES FROM ERV CONTROLLER**
4. Connect the 24V power for the sensor to the R terminal and the 24V Common to the C terminal of the thermostat
5. Reenergize the FRESH-PAK unit.
6. Once the ERV restarts (less than a minute) Test the sensor to ensure fan operation.

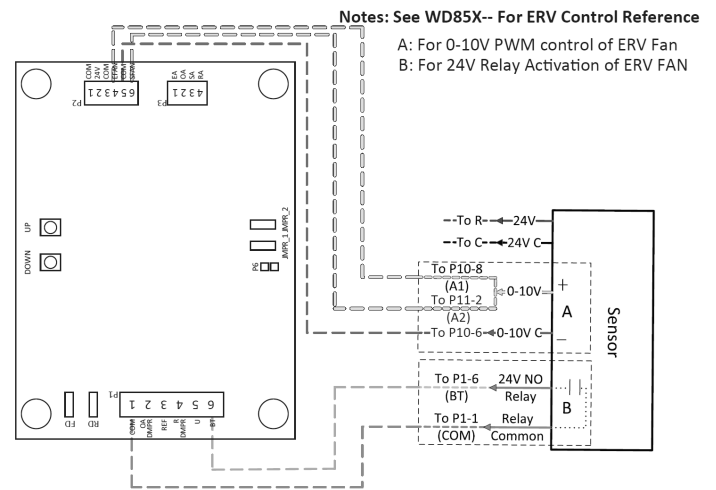
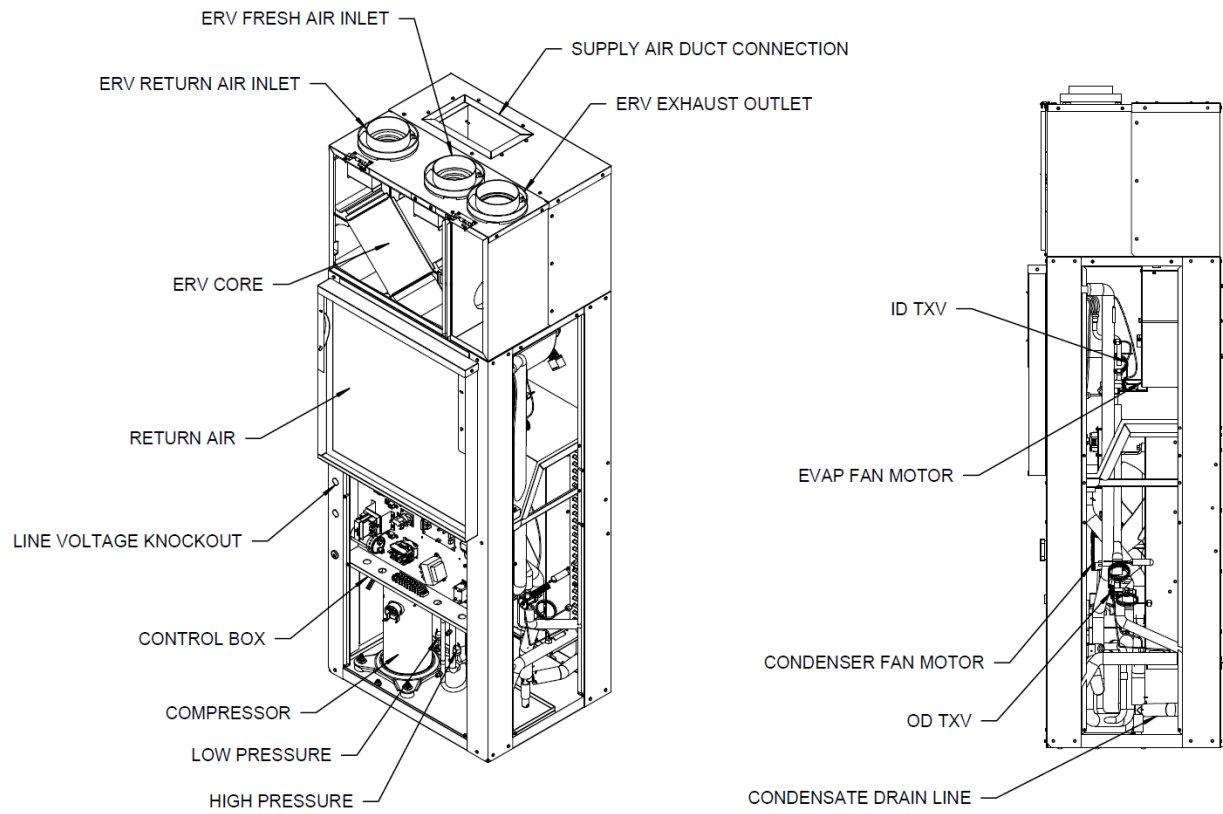

Figure 29 - CO2/ Humidity Sensor

# MAJOR COMPONENTS



**SIZE 12 UNITS ONLY**

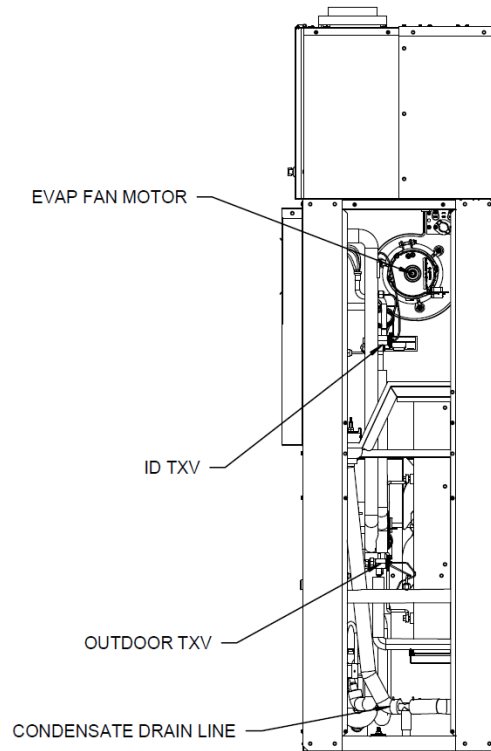

Figure 30 - Location of Major Components

# WIRING DIAGRAMS

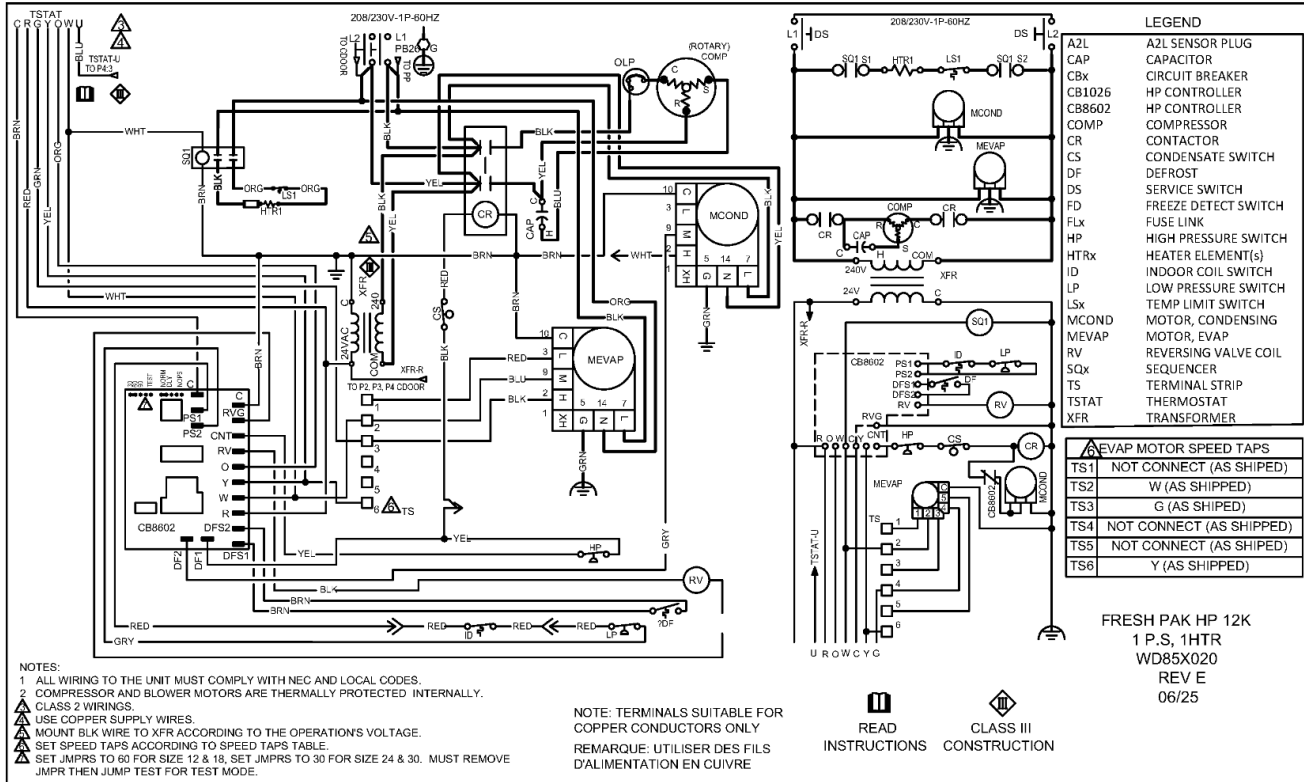

Figure 31 - Fresh Pak HP 3-5KW Rotary ECM -ECM 208/230V

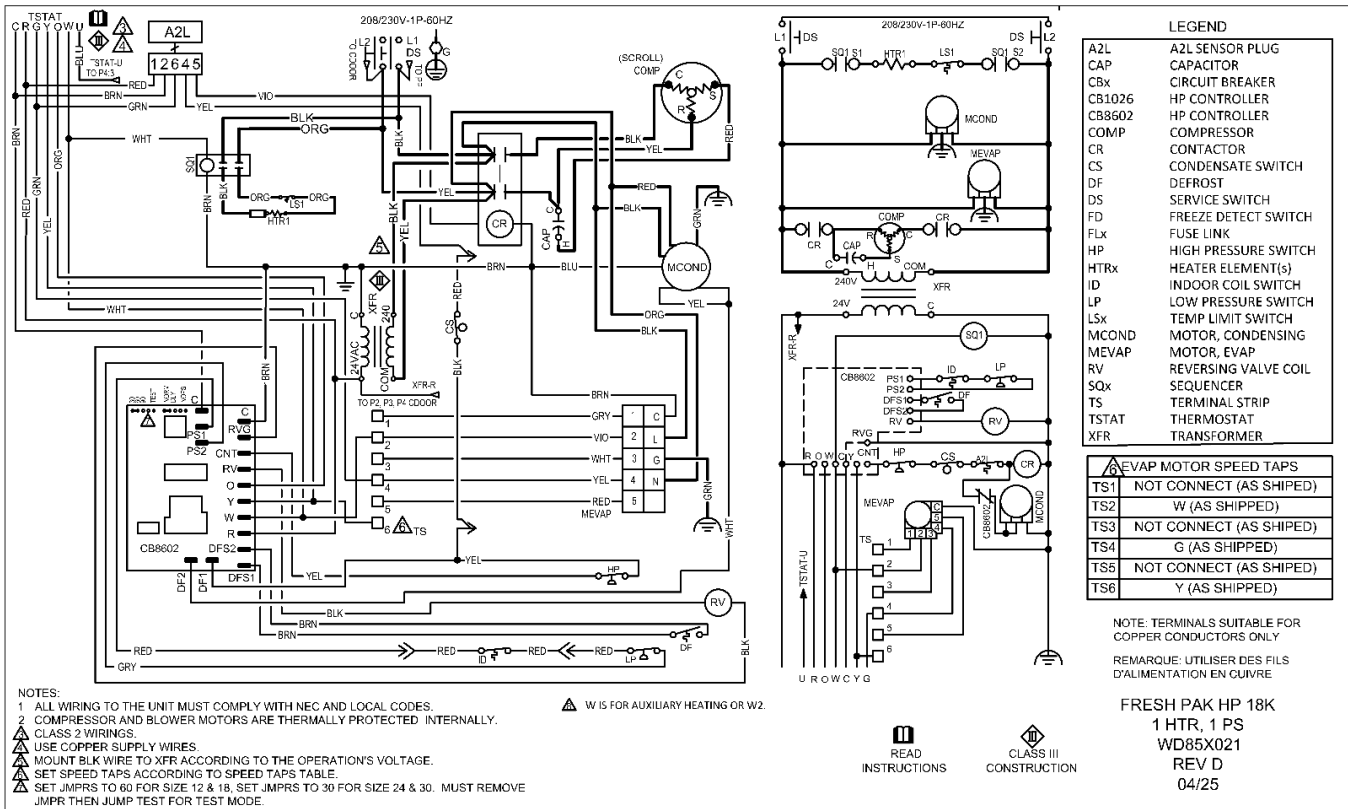

Figure 32 - Fresh Pak HP 18K, Scroll MDX-MDR 208/230V

# WIRING DIAGRAMS (continued)

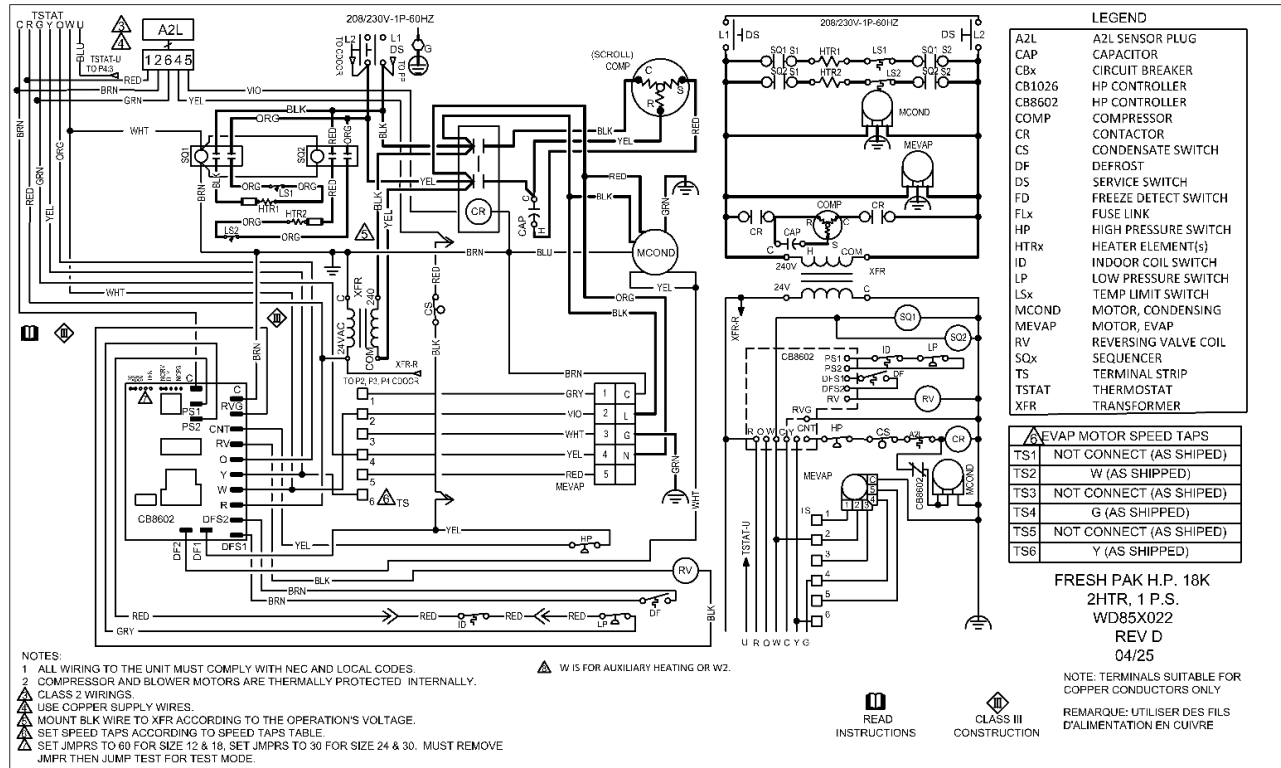

Figure 33 - Fresh PAK HP 18K, Rotary MDX-MDR 208V-230V

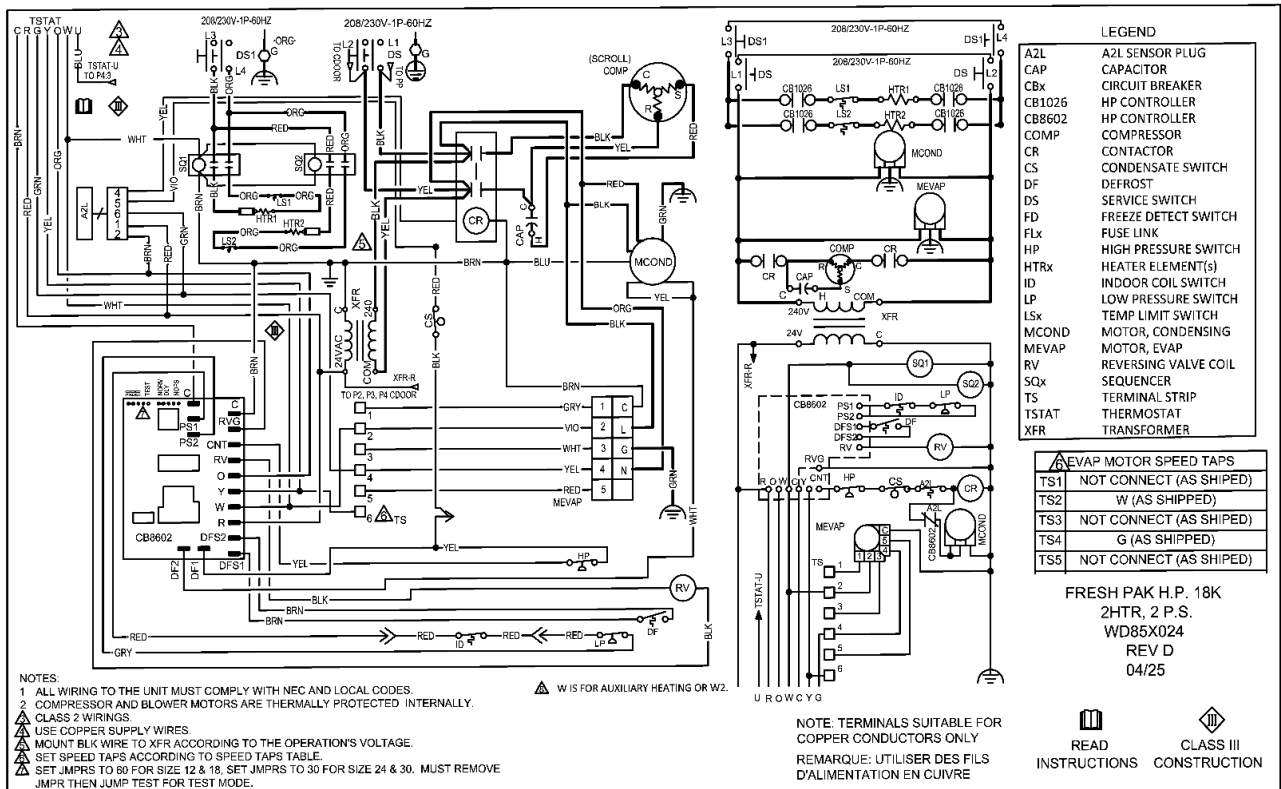

Figure 34 - Fresh PAK HP 18K, Rotary MDX-MDR 208V-230V

WIRING DIAGRAMS (continued)

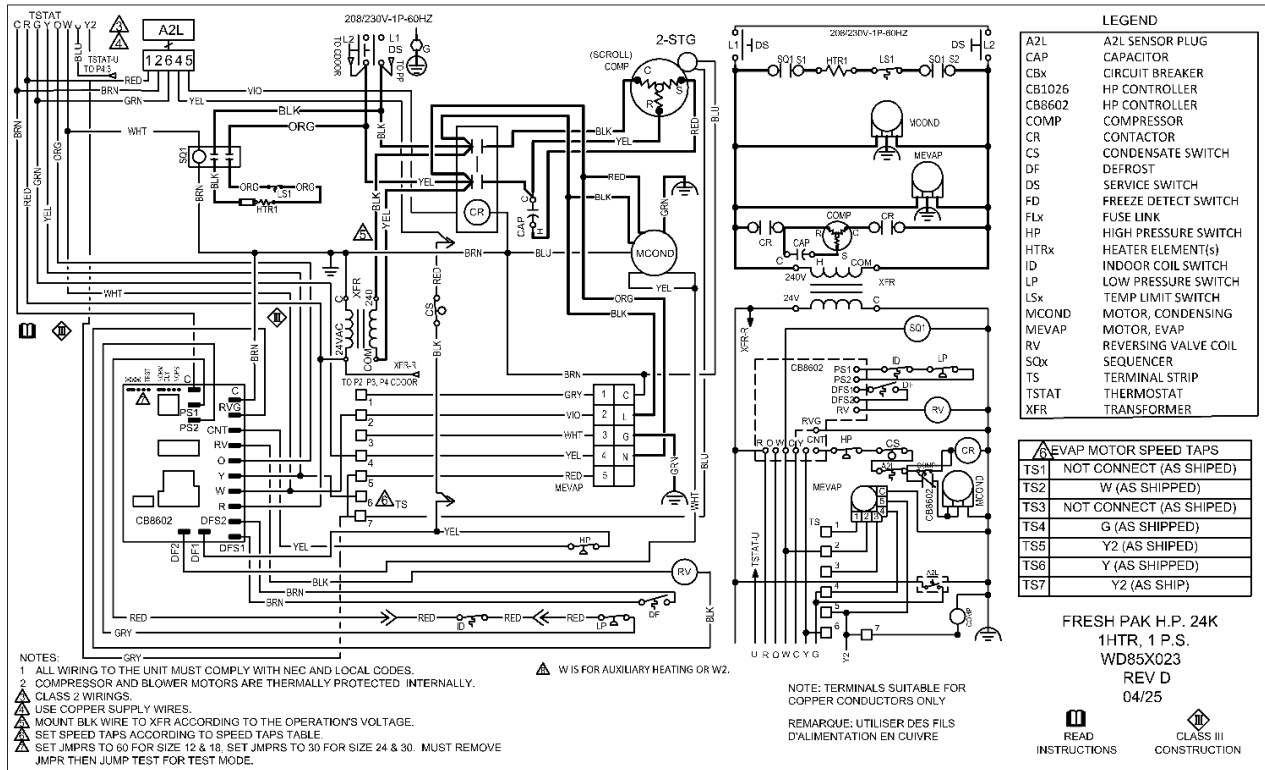

Figure 35 - Fresh Pak HP 24K, Rotary MDX-MDR 208V - 230V

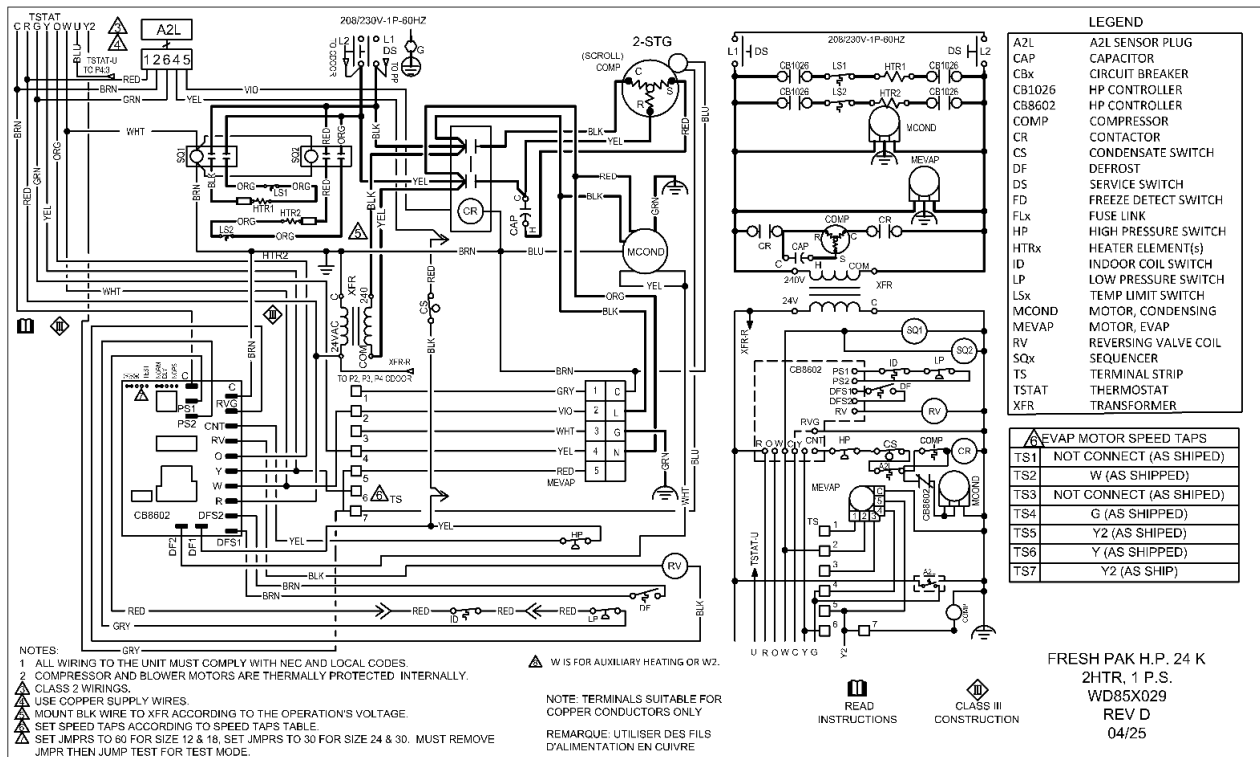

Figure 36 - Fresh Pak HP 24K, Uni Rotary MDX-MDR 208V - 230V



# WIRING DIAGRAMS (continued)

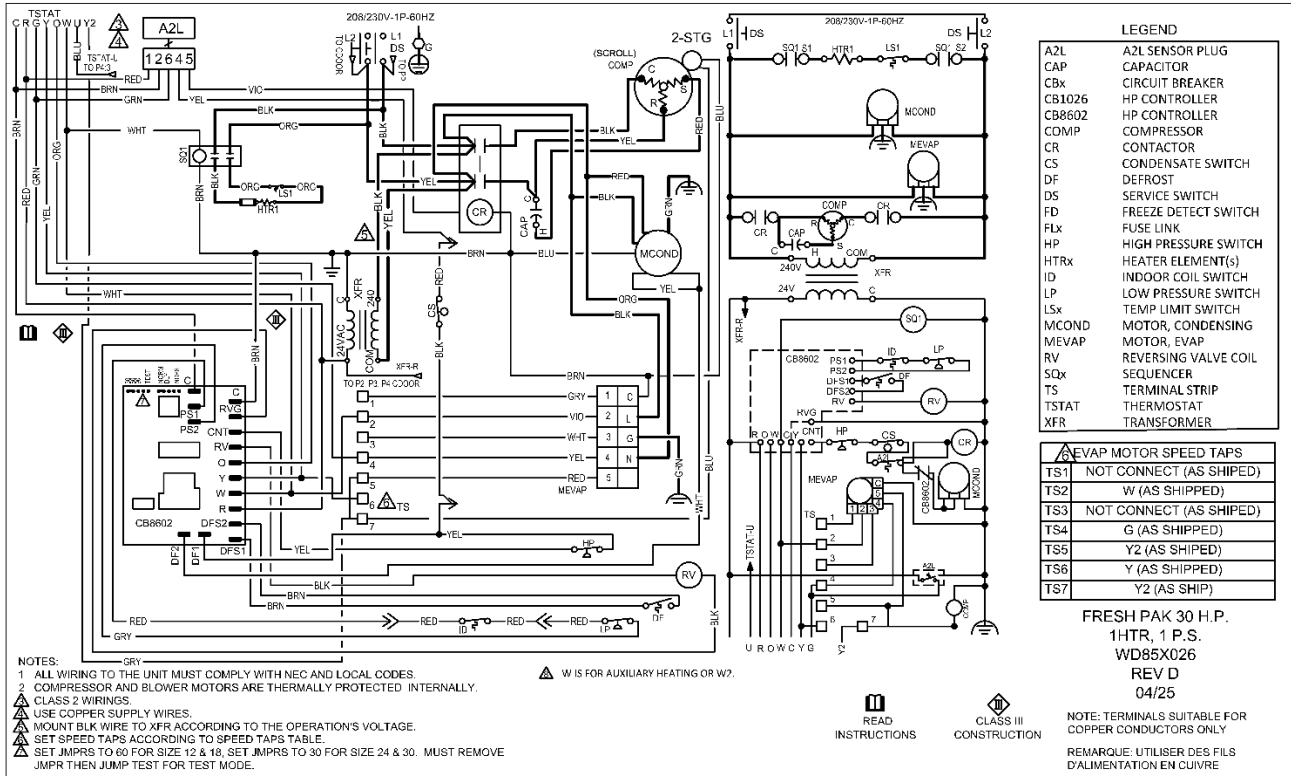

Figure 39 - Fresh PAK HP 30K Scroll MDX - MDR 208V - 230V

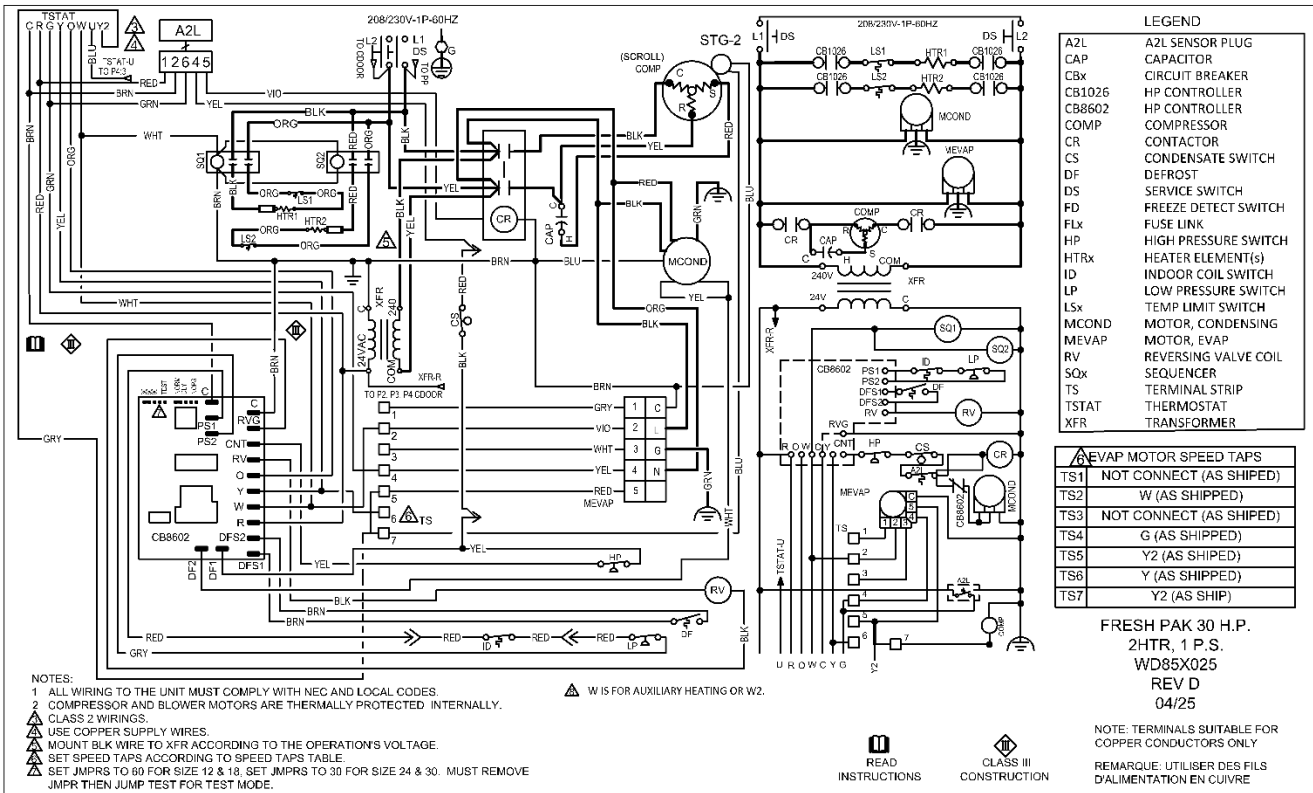

Figure 40 - Fresh PAK HP 30K, Scroll MDX - MDR 208V - 230V

# WIRING DIAGRAMS (continued)

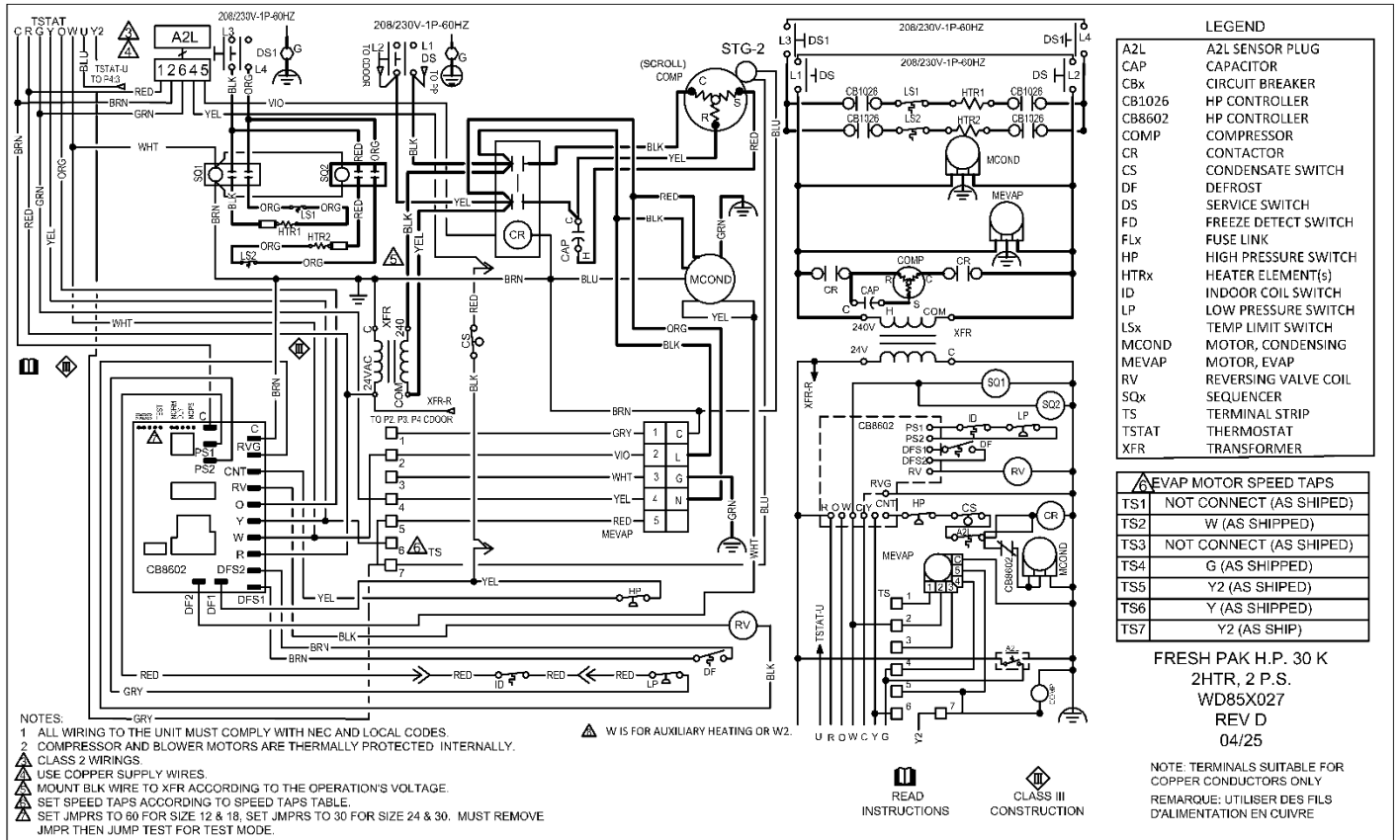

Figure 41 - Fresh Pak HP 30K, Scroll MDX - MDR

CIRCUIT SCHEMATIC

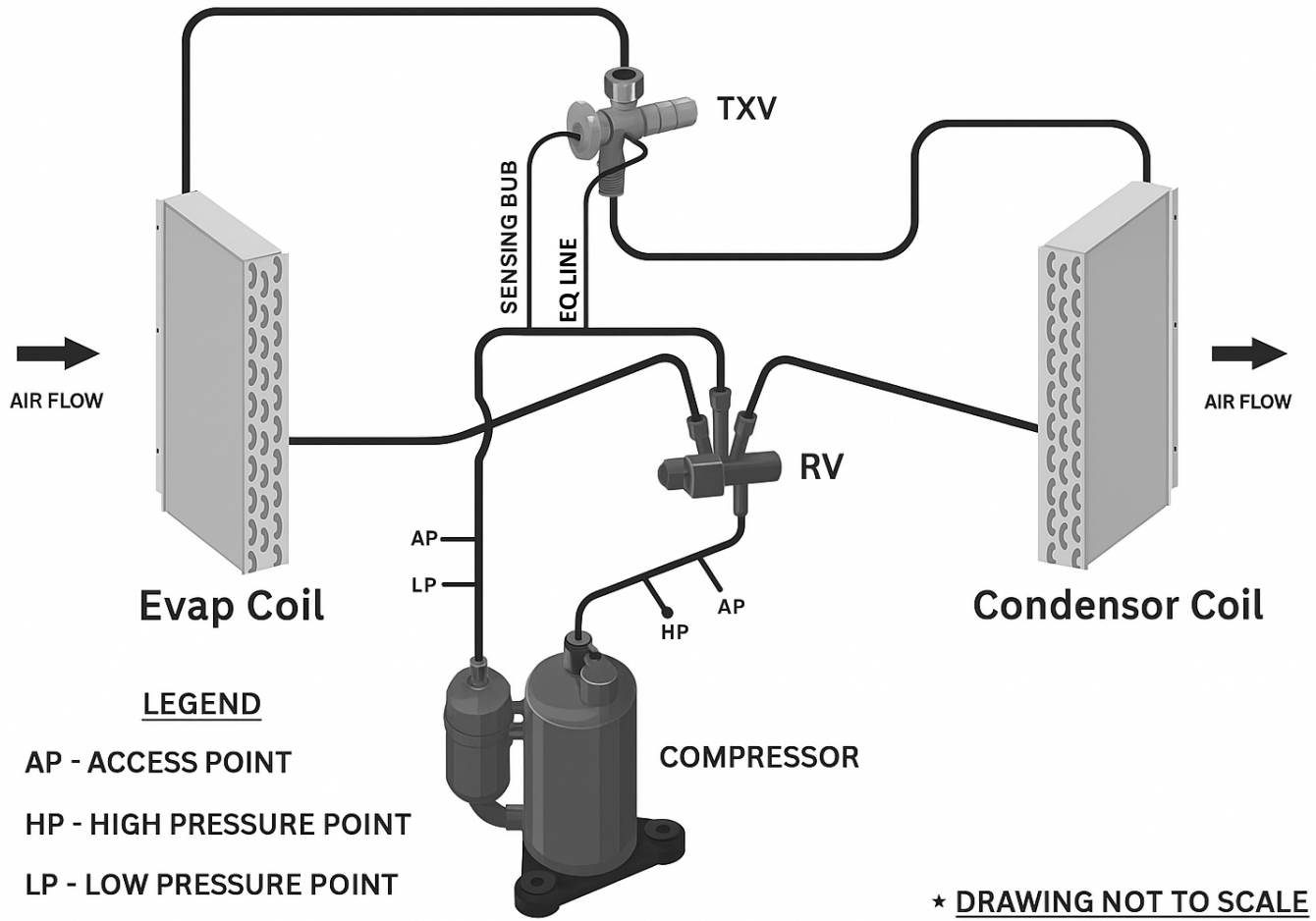





Figure 42 - Circuit Schematic ( Heat Pump)





## STARTUP INSTRUCTIONS

 **WARNING**   
Do not supply power to unit with the compressor terminal box cover removed

 **WARNING**   
Do not bypass or eliminate safety devices



 **WARNING**   
Do not exceed the maximum operating pressure listed on the unit rating plate.

 **WARNING**   
 **FIRE OR EXPLOSION HAZARD**   
Failure to following this warning could result in personal injury, death and/or property damage.  
Do not attempt any sealed system repair without first recovering the entire refrigerant charge. R-454B refrigerant and oil mixture could ignite in the presence of a brazing torch flame. Completely recover the refrigerant charge using both the high and low sides of the system and purge the sealed system with nitrogen before brazing any component or tubing.

 **WARNING**   
 **FIRE OR EXPLOSION HAZARD**   
Failure to following this warning could result in personal injury, death and/or property damage.  
Do not use flames or any potential ignition sources to leak check R-545B refrigerant tubing or components.

### PRE-STARTUP CHECKS

Before start-up, thoroughly check all the components. Optimal operation of equipment requires cleanliness. Often after installation of the equipment, additional construction activities occur. Protect the equipment from debris during these construction phases.

 **WARNING**   
Electrically ground the unit by connecting ground wire to ground lug. Failure to properly ground the unit may result in personal injury or death

 **CAUTION**   
Wire any field installed device such as a fan switch or thermostat furnished by the factory in strict accordance with the wiring diagram supplied with the unit. Failure to properly wire the unit could result in damage to components and will void all warranties

### PRIOR TO THE STARTUP OF THE UNIT

1. Ensure supply voltage matches nameplate data.
2. Ensure the unit is properly grounded
3. With the power off, check blower wheel set screws for proper tightness and that the blower wheel rotates freely.
4. Ensure unit will be accessible for servicing.
5. Ensure condensate line is properly sized, run, trapped, pitched and tested.
6. Ensure all cabinet openings and wiring connections have been sealed.
7. Ensure clean filters are in place.
8. Ensure all access panels are in place and secured.
9. Ensure that all air has been vented from the water coil.
10. Verify that all electrical connections are tight and secure.
11. Check the electrical overcurrent protection and wiring for the correct size.
12. Verify that the low voltage wiring between the thermostat and the unit matches the wiring diagram.
13. Check condensate overflow sensor for proper operation and adjust position if required.

### FRESH PAK HEAT PUMP UNITS

1. Set thermostat system switch to "OFF" position and fan switch to "Auto" position. Apply power to the FRESH-PAK Unit.
2. Set fan switch to "On", indoor blower should operate.
3. Return fan switch to "Auto", indoor blower should de-energize.
4. Set system switch to "Cool" and lower the thermostat set point to coldest setting. The compressor should energize as well as the outdoor fan and indoor blower.
5. Return thermostat set-point to a temperature warmer than room temperature and the compressor, indoor and outdoor fan should de-energize.

## STARTUP INSTRUCTIONS (cont.)



### NOTE



The FRESH-PAK employs a compressor short cycle delay (approx. 5 minutes) which will not allow the compressor to immediately restart following shut down. Additional delays may be experienced if using an electronic digital thermostat.

6. Move system switch to "Heat: and raise thermostat to a set point slightly higher than room temperature (less than 2 degrees). The compressor, outdoor fan and indoor blower should energize.
7. Raise set point to more than 2 degrees and the electric heaters should also energize.



### NOTE



The Fresh Pak heat pumps DO NOT have a low ambient cut-off switch.



### WARNING



FRESH-PAK Heat Pump units operate with the reversing valve energized in the COOLING mode. The thermostat must be wired or configured accordingly or the unit will not operate properly.

## STARTUP & PERFORMANCE CHECKLIST INSTRUCTIONS

The warranty may be void unless it is completed and returned to the warrantor. If the unit is not installed properly the warranty will be void as the manufacturer will not be held accountable for problems that stem from improper installation.

## TROUBLESHOOTING

PROBLEM	POSSIBLE CAUSE	CHECKS & CORRECTIONS
ENTIRE UNIT DOES NOT RUN	Power supply off	Apply power; close disconnect.
	Blown Fuse	Replace fuse or reset circuit breaker. Check for correct fuses.
	Voltage supply low	If voltage is below minimum voltage specified on unit data plate, contact power company.
	Thermostat	Set the fan to "ON", the fan should run. Set thermostat to "COOL" and lowest temperature setting, the unit should run in the cooling mode (reversing valve energized). Set unit to "HEAT" and the highest temperature setting, the unit should run in the heating mode. If neither the blower nor compressor run in all three cases, the thermostat could be mis-wired or faulty. To determine mis-wired or faulty thermostat verify 24 volts is available on the condenser section low voltage terminal strip between "R" and "C", "Y" and "C", and "B" and "C". If blower does not operate, verify 24 volts between terminals "G" and "C" in the air handler. Replace the thermostat if defective.
BLOWER OPERATES BUT COMPRESSOR DOES NOT RUN	Thermostat	Check setting, calibration and wiring.
	Wiring	Check for loose or broken wires at compressor, capacitor or contactor.
	Compressor overload open	If the compressor is cool and the overload will not reset, replace the compressor.
	Compressor motor grounded	Internal wiring grounded to the compressor shell. Replace compressor. If compressor burnout, install new filter dryer.
	Compressor windings open	After compressor has cooled, check continuity of compressor windings. If the windings are open, replace the compressor.
Refrigerant Sensor	For units over 4lbs, an active refrigerant leak will/faulty sensor will disable the compressor operation. Verify absence of refrigerant leak and replace sensor.	
UNIT OFF ON HIGH PRESSURE CONTROL	Discharge pressure too high	In "COOLING" mode: Lack of or inadequate air flow. Entering air temperature too warm. Blower inoperative, clogged filter or restriction in ductwork. In "HEATING" mode: Lack of or inadequate airflow. Entering air temperature too cold. Blower inoperative, clogged filter or restriction in ductwork.
	Refrigerant charge	The unit is overcharged with refrigerant. Reclaim refrigerant, evacuate and recharge with factory recommended charge.
	High pressure switch	Check for defective or improperly calibrated high-pressure switch.
UNIT OFF ON LOW PRESSURE CONTROL	Suction Pressure too low	In "COOLING" mode: Lack of or inadequate air flow. Entering air temperature too cold. Blower inoperative, clogged filter or restriction in ductwork. In "HEATING" mode: Lack of or inadequate airflow. Entering air temperature too warm. Blower inoperative, clogged filter or restriction in ductwork.
	Refrigerant charge	The unit is low on refrigerant. Check for refrigerant leak, repair, evacuate and recharge with factory recommended charge.
	Low pressure switch	Check for defective or improperly calibrated low-pressure switch.
UNIT SHORT CYCLES	Unit oversized	Recalculate heating and cooling loads.
	Thermostat	Thermostat installed near a supply air register, relocate thermostat. Check heat anticipator.
	Wiring and controls	Loose connections in the wiring or a defective compressor contactor.

Table 13 - Troubleshooting Table (1 of 2)

## TROUBLESHOOTING (continued)

PROBLEM	POSSIBLE CAUSE	CHECKS & CORRECTIONS
INSUFFICIENT COOLING OR HEATING	Unit undersized	Recalculate heating and cooling loads. If not excessive, possibly adding insulation will rectify the situation.
	Loss of conditioned air by leaks	Check for leaks in ductwork or introduction of ambient air through doors or windows.
	Airflow	Lack of adequate airflow or improper distribution of air. Replace dirty air filter.
	Refrigerant charge	Low on refrigerant charge causing inefficient operation.
	Compressor	Check for defective compressor. If discharge is too low and suction pressure is too high, compressor is not pumping properly. Replace compressor.
	Reversing valve	Defective reversing valve creating bypass of refrigerant from discharge to suction side of compressor. Discharge is too low and suction is too high. Replace reversing valve.
	Operating pressures	Compare unit operating pressures to the pressure / temperature chart for the unit.
	Refrigerant metering device	Check for possible restriction or defect. Replace if necessary.
	Moisture, non-condensable	The refrigerant system may be contaminated with moisture or non-condensable. Reclaim refrigerant, evacuate and recharge with factory recommended charge.
A2L SENSOR STATUS LIGHT	Solid Green	Sensor is in startup mode
	Blinking Green	Sensor is in normal operation
	Solid Red	Sensor has detected a leak and is in mitigation mode
	Blinking Red	Sensor fault, unit compressor will not energize and fan will be continuous

Table 14 - Troubleshooting Table (2 of 2)

# OPERATION & MAINTENANCE

**WARNING**

**FIRE OR EXPLOSION HAZARD**

IMPROPER HANDLING OF REFRIGERANTS CAN CAUSE INJURY, EXPLOSION AND DEATH

- It is illegal to release refrigerant into the atmosphere. Refrigerant released into an enclosed space will displace oxygen causing unconsciousness and death.
- If an indoor refrigerant leak is suspected, thoroughly ventilate the area before beginning any work
- DO NOT purge or allow refrigerant to be released into an interior space
- Contact with liquid refrigerant can cause frostbite and blindness. Avoid skin contact with liquid refrigerant, wear goggles and gloves when working with refrigerants. Seek medical help immediately if any refrigerant contact with skin or eyes occurs
- Never burn refrigerant as highly toxic gas will be produced
- Only EPA certified technicians should handle refrigerants.
- In Canada technicians must be ODP / ODS certified to handle refrigerants
- Follow all EPA regulations

**WARNING**

**FIRE OR EXPLOSION HAZARD**

Explosion risk, recover refrigerant only in a cylinder designed and intended for this purpose

- Do not use a damaged cylinder
- Do not apply flame or excessive heat to a refrigerant cylinder
- Do not fill a refrigerant cylinder to more than 80% of its capacity
- Do not use a refrigerant cylinder for anything other than its designed and intended purpose
- Do not use an expired refrigerant cylinder
- Use recovery equipment designed to handle the refrigerant being recovered
- Earth-ground refrigerant cylinders before using

**CAUTION**

Compressors and sealed system tubing components may be extremely hot!

**CAUTION**

Do not use compressors to evacuate the air conditioning system. A vacuum may cause internal electrical arcing resulting in a damaged or failed compressor.

**PREVENTIVE MAINTENANCE**

To achieve maximum performance and service life of equipment, a formal schedule of regular maintenance should be established and adhered to. Failure to establish and perform preventative maintenance program can void the manufacturer's warranty.

If servicing or major repairs are required, the complete unit can be removed as follows:

1. Disconnect the electrical power circuit supplying the unit.
2. Remove line and low voltage wiring from unit,
3. Remove rear access panel.
4. Remove supply duct from top of unit.
5. Slide unit back out of sleeve.
6. Unit may be removed from closet.

To reinstall unit, use the installation procedure outlined above.

Fresh Pak units are factory charged with refrigerant. All units use an adjustable thermostatic expansion valve (TXV) to control refrigerant flow to the evaporator coil. Do not adjust the TXV unless an evaluation of the system as described below indicates it is necessary. Superheat is increased (decrease refrigerant flow) by turning the TXV stem clockwise, turning the stem counter-clockwise will decrease superheat (increase refrigerant flow). Ideal conditions for checking refrigerant charge in cooling mode exist when the outdoor temperature is above 70°F (21° C) and indoor temperature is between 70°F (21°C) & 80°F (26.7° C).

Cooling Capacity	12K HP	18K HP	24K HP	30K HP
Subcooling	8	8	16	10
Superheat at coil	14	7	9	8
Superheat at compressor	17	20	16	10

**NOTE**

Subcooling and superheat readings are reliable when the conditioned space is at comfortable conditions

## OPERATION & MAINTENANCE(continued)

**WARNING**

It is a violation of federal law to discharge refrigerant into the atmosphere. Use proper reclaiming methods and equipment when installing or servicing this unit. Service should be performed by a QUALIFIED service agency.

The refrigerant system contained in the unit normally requires no maintenance since it is a closed, self-contained system.

**CAUTION**

All appropriate personal protection equipment should be worn when servicing or maintaining this unit. Personal injury can result from contact with sharp metal edges, moving parts, and hot or cold surfaces.

### FAN

The fan should be inspected and cleaned annually in conjunction with maintenance of the motor and bearings. It is important to keep the fan section and motor clean and free from obstruction to prevent imbalance, vibration, and improper operation.

**WARNING**

**ELECTRIC SHOCK HAZARD**

Check motor connections to ensure they are secure and in accordance with the unit wiring diagram.

ECM motors have line voltage power applied at all times.

**VERIFY THAT POWER IS DISCONNECTED BEFORE SERVICING**

### FILTER

The air filter and ERV filters should be cleaned or replaced every 30 days or more frequently if severe operating conditions exist. Always replace the filter with the same type and size as originally furnished.

### ERV CORE

The Energy Recovery plate heat exchanger (CORE), should be inspected at least two (2) times a year. The CORE should be removed and cleaned as needed at least once (1) per year. The CORE can be cleaned with light air pressure or with a mild detergent and water solution. Be sure that the CORE is completely dry before reinserting it back into the ERV.

### ERV INSULATION

The ERV interior should be inspected with the CORE (2 times a year). Check and clean the cabinet interior of all dirt and debris.

### COIL

Clean all heat transfer surfaces and remove all dirt, dust, and contaminants that potentially impairs air flow using industry accepted practices. Care should be taken not to bend coil fin material.

### CONDENSATE DRAIN PAN AND PIPE

Check and clean all dirt and debris from pan. Ensure drain line is free flowing and unobstructed.

### MAINTENANCE UPDATES

Check regularly for a current copy of the maintenance program log which can be found at under "product information".

### UNIT PERFORMANCE

Record performance measurements of volts, amps and air temperature differences (both heating and cooling). A comparison of logged data with start-up and other annual data is useful as an indicator of general equipment condition.

### UNIT LOCKOUT

Air flow problems could cause periodic lockouts. The lockout (shutdown) of the units is a normal protective result. Check for airflow rates (may be caused by dirty filter) and air temperatures.

### LABORATORY TESTING

When the unit has less than 100 operational hours and the coils have not had sufficient time to be "seasoned", it is necessary to clean the coils with mild surfactant such as Calgon to remove the oils left by manufacturing processes.

## OPERATION & MAINTENANCE (continued)

Compressor bearing products designed for A2L refrigerants may come equipped with a factory installed refrigerant leak detection system. If the sensor is faulty, or disconnected, the appliance will not properly function.

False ceilings or drop ceilings may be used as a return air plenum if a refrigerant detection system is provided in the appliance and any external connections are also provided with a sensor immediately below the return air plenum duct joint.

### QUALIFICATION OF WORKERS

Service shall only be performed by qualified technicians, certified by national training organizations or manufacturers that are accredited to teach the relevant national competency standards that may be set in legislation. Competence to properly service the appliance should be documented by a certificate.

### CHECKS TO THE WORK AREA

Prior to beginning work on the appliance, safety checks are necessary to ensure that the risk of ignition of released gasses is minimized. Work shall be undertaken under a controlled procedure so as to minimize the risk of a flammable gas or vapor being present while the work is being performed.

All maintenance staff and others working in the local area shall be instructed on the nature of work being carried out. Work in confined spaces shall be avoided.

### CHECKING FOR PRESENCE OF REFRIGERANT

The area shall be checked with an appropriate refrigerant detector prior to and during work, to ensure the technician is aware of potentially toxic or flammable atmospheres. Ensure that the leak detection equipment being used is suitable for use with all applicable refrigerants, i.e. non-sparking, adequately sealed or intrinsically safe.

If any hot work is to be conducted on the refrigerating equipment or any associated parts, appropriate fire extinguishing equipment shall be available to hand. Have a dry powder or CO<sub>2</sub> fire extinguisher adjacent to the charging area.

No person carrying out work in relation to a REFRIGERATING SYSTEM which involves exposing any such a pipe work shall use any sources of ignition in manner that it may lead to the risk of fire or explosion.

All possible ignition sources, including cigarette smoking, should be kept sufficiently far away from the site of installation, repairing, removing and disposal, during which refrigerant can possibly be released to the surrounding space. Prior to work taking place, the area around the equipment is to be surveyed to make sure that there are no flammable hazards or ignition risks. "NO SMOKING" signs shall be displayed.

### VENTILATED AREA

Ensure that the area is in the open or that it is adequately ventilated before breaking into the system or conducting any hot work. A degree of ventilation shall continue during the period that the work is carried out. The ventilation should safely disperse any released refrigerant and preferably expel it externally into the atmosphere.

### CHECKS TO THE REFREIGERATING EQUIPMENT

Where electrical components are being changed, they shall be fit for the purpose and to the correct specification. At all times the manufacturer's maintenance and service guidelines shall be followed. If in doubt, consult the manufacturer's technical department for assistance.

The following checks shall be applied to installations using FLAMMANLE REFRIGERANTS:

- The actual REFRIGERANT CHARGE is in accordance with the room size within which the refrigerant containing parts are installed;
- The ventilation machinery and outlets are operating adequately and are not obstructed;
- Marking to the equipment continues to be visible and legible. Markings and signs that are illegible shall be corrected;
- Refrigerating pipe or components are installed in a position where they are unlikely to be exposed to any substance which may corrode refrigerant containing components, unless the components are constructed of materials which are inherently resistant to being corroded or are suitably protected against being so corroded.

## OPERATION & MAINTENANCE (continued)

### CHECKS TO ELECTRICAL DEVICES AND SEALED

#### ELECTRICAL COMPONENTS

Repair and maintenance to electrical components shall include initial safety checks and component inspection procedures. If a fault exists that could compromise safety, then no electrical supply shall be connected to the circuit until it is satisfactorily dealt with. If the fault cannot be corrected immediately but it is necessary to continue operation, an adequate temporary solution shall be used. This shall be reported to the owner of the equipment so all parties are advised.

Initial Safety Checks shall include:

- That capacitors are discharged: this shall be done in a safe manner to avoid possibility of sparking;
- That no live electrical components and wiring are exposed while charging, recovering or purging the system;
- That there is continuity of earth bonding.

Sealed electrical components shall be replaced in the event of damage or malfunction.

#### CABLING

Check that cabling will not be subject to wear, corrosion, excessive pressure, vibration, sharp edges or any other adverse environmental effects. The check shall also take into account the effects of aging or continual vibration from sources such as compressors or fans.

#### DETECTION OF FLAMMABLE REFRIGERANTS

Under no circumstances shall potential sources of ignition be used in the searching for or detection of refrigerant leaks. A halide torch (or any other detector using a naked flame) shall not be used.

Electronic leak detectors may be used to detect refrigerant leaks but, in the case of FLAMMABLE REFRIGERANTS, the sensitivity may not be adequate, or may need re-calibration. (Detection equipment shall be calibrated in a refrigerant-free area.) Ensure that the detector is not a potential source of ignition and is suitable for the refrigerant used. Leak detection equipment shall be set at a percentage of the LFL of the refrigerant and shall be calibrated to the refrigerant employed, and the appropriate percentage of gas (25 % maximum) is confirmed.

Leak detection fluids (such as the bubble method or fluorescent method agents) are also suitable for use with most refrigerants but the use of detergents containing chlorine shall be avoided as the chlorine may react with the refrigerant and corrode the copper pipe-work.

If a leak is suspected, all naked flames shall be removed/extinguished. If a leakage of refrigerant is found which requires brazing, all of the refrigerant shall be recovered from the system, or isolated (by means of shut off valves) in a part of the system remote from the leak.

#### REMOVAL AND EVACUATION OF FLAMMABLE REFRIGERANTS

When breaking into the refrigerant circuit to make repairs – or for any other purpose – conventional procedures shall be used. However, for FLAMMABLE REFRIGERANTS it is important that best practice is followed since flammability is a consideration. The following procedure shall be adhered to:

- Remove refrigerant charge following local and national regulations
- Purge the circuit with inert gas (optional for A2L);
- Evacuate (optional for A2L)
- If using flame to open circuit, continuously flush system with an inert gas
- Open the circuit by cutting or brazing.

The refrigerant charge shall be recovered into the correct recovery cylinders if venting is not allowed by local and national codes. For appliances containing flammable refrigerants, the system shall be purged with oxygen-free nitrogen to render the appliance safe for flammable refrigerants. This process might need to be repeated several times. Compressed air or oxygen shall not be used for purging refrigerant systems.

For appliances containing flammable refrigerants, refrigerant purging shall be achieved by breaking the vacuum in the system with oxygen-free nitrogen and continuing until the working pressure is achieved, then venting to the atmosphere, and finally pulling down to a vacuum (optional for A2L). This process shall be repeated until no refrigerant is within the system (optional for A2L). When the final oxygen-free nitrogen charge is used, the system shall be vented down to atmospheric pressure to enable work to take place. The outlet for the vacuum pump shall not be close to any potential ignition sources, and ventilation shall be available.

## OPERATION & MAINTENANCE (continued)

### CHARGING PROCEDURES

In addition to conventional charging procedures, the following requirements shall be followed.

- Ensure that contamination of different refrigerants does not occur when using charging equipment. Hoses or lines shall be as short as possible to minimize the amount of refrigerant contained in them.
- Cylinders shall be kept in an appropriate position according to the instructions.
- Ensure that the REFRIGERATING SYSTEM is earthed prior to charging the system with refrigerant.
- Label the system when charging is complete (if not already).
- Extreme care shall be taken not to overfill the REFRIGERATING SYSTEM.

Prior to recharging the system, it shall be pressure-tested with the appropriate purging gas. The system shall be leak-tested on completion of charging but prior to commissioning. A follow up leak test shall be carried out prior to leaving the site.

### DECOMMISSIONING

Before carrying out this procedure, it is essential that the technician is completely familiar with the equipment and all its detail. It is recommended good practice that all refrigerants are recovered safely. Prior to the task being carried out, an oil and refrigerant sample shall be taken in case analysis is required prior to re-use of recovered refrigerant. It is essential that electrical power is available before the task is commenced.

- A. Become familiar with the equipment and its operation.
- B. Isolate system electrically.
- C. Before attempting the procedure, ensure that:
  - a. mechanical handling equipment is available, if required, for handling refrigerant cylinders;
  - b. all personal protective equipment is available and being used correctly;
  - c. the recovery process is supervised at all times by a competent person;
  - d. recovery equipment and cylinders conform to the appropriate standards.
- D. Pump down refrigerant system, if possible.
- E. If a vacuum is not possible, make a manifold so that refrigerant can be removed from various parts of the system.

- F. Make sure that cylinder is situated on the scales before recovery takes place.
- G. Start the recovery machine and operate in accordance with instructions.
- H. Do not overfill cylinders (no more than 80 % volume liquid charge).
- I. Do not exceed the maximum working pressure of the cylinder, even temporarily.
- J. When the cylinders have been filled correctly and the process completed, make sure that the cylinders and the equipment are removed from site promptly and all isolation valves on the equipment are closed off.
- K. Recovered refrigerant shall not be charged into another REFRIGERATING SYSTEM unless it has been cleaned and checked.

### LABELING

Equipment shall be labelled stating that it has been de-commissioned and emptied of refrigerant. The label shall be dated and signed. For appliances containing FLAMMABLE REFRIGERANTS, ensure that there are labels on the equipment stating that the equipment contains FLAMMABLE REFRIGERANT.

### RECOVERY

When removing refrigerant from a system, either for servicing order commissioning, it is recommended good practice that all refrigerants are removed safely. When transferring refrigerant into cylinders, ensure that only appropriate refrigerant recovery cylinders are employed. Ensure that the correct number of cylinders for holding the total system charge is available. All cylinders to be used are designated for the recovered refrigerant and labelled for that refrigerant (i.e. special cylinders for the recovery of refrigerant). Cylinders shall be complete with pressure-relief valve and associated shut-off valves in good working order. Empty recovery cylinders are evacuated and, if possible, cooled before recovery occurs.

The recovery equipment shall be in good working order with a set of instructions concerning the equipment that is at hand and shall be suitable for the recovery of the flammable refrigerant. If in doubt, the manufacturer should be consulted. In addition, a set of calibrated weighing scales shall be available and in good working order. Hoses shall be complete with leak-free disconnect couplings and in good condition.

## OPERATION & MAINTENANCE (continued)

---

The recovered refrigerant shall be processed according to local Legislation in the correct recovery cylinder, and the relevant waste transfer note arranged. Do not mix refrigerants in recovery units and especially not in cylinders.

If compressors or compressor oils are to be removed, ensure that they have been evacuated to an acceptable level to make certain that flammable refrigerant does not remain within the lubricant. The compressor body shall not be heated by an open flame or other ignition sources to accelerate this process. When oil is drained from a system, it shall be carried out safely

### REFRIGERANT DETECTION SENSOR (RDS) INFORMATION

Refer to the appliance IOM for information regarding the minimum conditioned room requirements, and instructions for the RDS operation, installation, and wiring. Any field installed wiring connected to the RDS must be at least 18AWG and have minimum insulation thickness of 1.58mm or be protected from damage.

The RDS is not intended for service or repair. In the event of a sensor failure, the mitigation mode will engage and the sensor shall be replaced by removing the sensor and replacing it with a new sensor.

### DUCTING

If the appliance is connected via an air duct system to one or more rooms with A2L refrigerants is installed in a room with an area of less than the minimum as noted on the unit physical data table, or a minimum effective dispersal volume less than 18m<sup>3</sup>(636 ft<sup>3</sup>), the room shall be without continuously operating open flames (e.g. an operating gas appliance), or other potential ignition sources (such as an operating electric heater/ hot surface). A flame producing device may be installed in the same space if the device is provided with an effective flame arrest.

Auxiliary devices which may be a potential ignition source shall not be installed in the duct work. Potential ignition sources include hot surfaces with a temperature exceeding 430°C (806°F) and electric switching devices.

### PIPING

Pipe-work including piping material, pipe routing, and installation shall include protection from physical damage in operation and service, and be in compliance with national and local codes and standards, such as AHRAE 15, ASHRAE 15.2, IAPMO uniform mechanical code, ICC International Mechanical Code, or CSA B52. All field joints shall be accessible for inspection prior to being covered or enclosed.

## PERFORMANCE TABLES

ERV EFFECTIVENESS TABLE							
SUPPLY TEMPERATURE		RELATIVE HUMIDITY	SUPPLY AIR FLOW		RECOVERY		
°C	°F		L/s	CFM	SENSIBLE	LATENT	TOTAL
		RH %	Effectiveness %				
2	35	80	47	100	62.4	41.9	54.7
0	32	80	23	50	70.7	53.6	65
0	32	80	37	80	65.4	46	59
0	32	80	56	120	59.7	38.5	52.7
-25	-13	80	47	100	65.4	41.9	56.2

Table 15 - ERV Effectiveness

VENTILATION PERFORMANCE					
EXTERNAL STATIC PRESSURE		SUPPLY AIR FLOW		EXHAUST AIR FLOW	
Pa	in. W.C.	L/s	CFM	L/s	CFM
25	0.1	60	127	60	127
50	0.2	56	119	56	119
75	0.3	55	117	55	117
100	0.4	52	110	52	110
125	0.5	49	104	49	104
150	0.6	47	100	47	100
175	0.7	46	97	46	97
200	0.8	41	87	41	87
225	0.9	37	78	37	78
250	1.0	34	72	34	72

Table 16 - Ventilation Performance

Data is subject to change. Please verify most current information on [www.firstco.com](http://www.firstco.com) or [www.AE-Air.com](http://www.AE-Air.com) websites.

# SUPPORT MATERIAL

## ASHRAE 62.2 VENTILATION STANDARD TABLES

ASHRAE 62.2 CFM Sizing Chart					
FLOOR AREA	NUMBER OF BEDROOMS / CFM				
	0-1	2-3	4-5	6-7	>7
< 1500	30	45	60	75	90
1501 – 3000	45	60	75	90	105
3001 – 4500	60	75	90	105	120
4501 – 6000	75	90	105	120	135
6001 – 7500	90	105	120	135	150
> 7500	105	120	135	150	165

ANSI/ASHRAE STANDARD 62.2-2010 – Ventilation Air Requirements; values in cfm. The above chart outlines the minimum requirements for continuous ventilation.

**Table 17 - ASHRAE 62.2 CFM Sizing Chart**

ROOM COUNT CALCULATION METHOD TABLE				
LIVING SPACE	NUMBER OF ROOMS	X CFM (or L/s)	=	CFM Required
Master Bedroom		x 20 cfm (for 10 L/s)	=	
Basement		x 20 cfm (for 10 L/s)	=	
Single Bedroom		x 10 cfm (for 5 L/s)	=	
Living Room		x 10 cfm (for 5 L/s)	=	
Dining Room		x 10 cfm (for 5 L/s)	=	
Family Room		x 10 cfm (for 5 L/s)	=	
Recreation Room		x 10 cfm (for 5 L/s)	=	
Other		x 10 cfm (for 5 L/s)	=	
Kitchen		x 10 cfm (for 5 L/s)	=	
Bathroom		x 10 cfm (for 5 L/s)	=	
Laundry Room		x 10 cfm (for 5 L/s)	=	
Utility Room		x 10 cfm (for 5 L/s)	=	
TOTAL VENTILATION REQUIREMENT			=	

**Table 18- Room Count Calculation Method Table**

Data is subject to change. Please verify most current information on [www.firstco.com](http://www.firstco.com) or [www.AE-Air.com](http://www.AE-Air.com) websites.

# STARTUP & PERFORMANCE CHECKLIST



CUSTOMER \_\_\_\_\_ STARTUP DATE \_\_\_\_\_ JOB # \_\_\_\_\_  
 ADDRESS \_\_\_\_\_ SERVICING COMPANY \_\_\_\_\_  
 \_\_\_\_\_ TECHNICIAN \_\_\_\_\_  
 MODEL # \_\_\_\_\_ SERIAL # \_\_\_\_\_ PHONE # \_\_\_\_\_

## INSTALLATION CHECK LIST

- Inspect the unit for transit damage and report any damage on the carrier's freight bill.
- Check model number to insure it matches the job requirements.
- Install field accessories and unit adapter panels as required. Follow accessory and installation manuals.
- Verify field wiring, including the wiring to any accessories.
- Check all multi-tap transformers, to ensure they are set to the proper incoming voltage.
- Power the unit. Bump the motor contractor to check rotation. Three phase motors are synchronized at the factory. If the blower fans are running backwards, de-energize power to the unit, then swap two of the three incoming electrical lines to obtain proper phasing. Re-check.
- Perform all start up procedures outline in the installation manual shipped with the unit.
- Fill in the Start Up information as outlined below and on the following page.
- Provide owner with information packet. Explain the thermostat and unit operation.

## START UP INFORMATION SHEET

### ELECTRICAL

Supply Voltage L1-L2 \_\_\_\_\_ Compressor Amps \_\_\_\_\_  
 Running Voltage L1-L2 \_\_\_\_\_ Blower Amps \_\_\_\_\_  
 Secondary Voltage \_\_\_\_\_ Condenser Fan Amps \_\_\_\_\_  
 C (black) to G (green) Volts\* \_\_\_\_\_  
 C (black) t W (white) Volts\* \_\_\_\_\_ \*With thermostat calling.

### AIRFLOW

Intake Design CFM	Exhaust Design CFM	
Pressure Drop _____	Pressure Drop _____	
Calculated CFM _____	Calculated CFM _____	
Amb db Temp _____	Amb db Temp _____	
Return Air db Temp* _____	Return Air db Temp* _____	
Tempered Air db Temp* _____	Tempered Air db Temp* _____	*Measure after 15 minutes of run time.

### TEMPERATURES

Outdoor Air Temperature _____ DB _____ WB	Cooling Supply Air Temperature _____ DB _____ WB
Return Air Temperature _____ DB _____ WB	Heating Supply Air Temperature _____ DB _____ WB

DOCUMENT #: \_\_\_\_\_

# STARTUP & PERFORMANCE CHECKLIST



## UNIT OPERATION

### HEATING MODE

- 1 INDOOR BLOWER AMPS \_\_\_\_\_
- 2 TEMPERATURE RISE
  - Supply Duct Temperature \_\_\_\_\_
  - Return Duct Temperature - \_\_\_\_\_
  - Temperature Rise = \_\_\_\_\_
- 3 TOTAL EXTERNAL STATIC
  - Supply Duct Temperature \_\_\_\_\_
  - Return Duct Temperature + \_\_\_\_\_
  - Temperature Rise = \_\_\_\_\_
- 4 CONDENSATE LINE
  - Leak Free

### COOLING MODE

- 5 INDOOR BLOWER AMPS \_\_\_\_\_
- 6 TEMPERATURE DROP
  - Return Duct Temperature \_\_\_\_\_
  - Supply Duct Temperature - \_\_\_\_\_
  - Temperature Drop = \_\_\_\_\_
- 7 TOTAL EXTERNAL STATIC
  - Supply External Static \_\_\_\_\_
  - Return External Static + \_\_\_\_\_
  - Total External Static = \_\_\_\_\_
- 8 DRAIN LINE
  - Leak Free
- 9 THERMOSTAT
  - Adjusted & Programmed
  - Explained Operation to Owner

The warranty may be void unless the Startup & Performance Checklist is completed and returned to the warrantor. If the HVAC unit is not installed properly the warranty will be void as the manufacturer can't be held accountable for problems that stem from improper installation.

# NOTES

---



P.O. Box 270969 Dallas, TX 75227  
[www.firstco.com](http://www.firstco.com) or [www.ae-air.com](http://www.ae-air.com)

The manufacturer works to continually improve its products. It reserves the right to change design and specifications without notice.

©2022 First Co., Applied Environmental Air