

Installation, Operation, & Maintenance

IOM8083D02
Rev. A 03/26

DDC CONTROLLER WATER SOURCE HEAT PUMP STANDARD OPTION (NO HGRH)



HydroTechTM R-410A Water Source Heat Pump

ATTENTION:

Read all instructions thoroughly and retain all manuals for future reference.

COPYRIGHT

In accordance with its policy of continuous product improvement, First, Co. and AE Air reserve the right to modify, change, or discontinue specifications or designs at any time without notice and without incurring obligation.

©2026 First Co. / AE-Air, 8273 Moberly Lane, Dallas, TX 75227



WARNING



Do NOT modify this product or install non-authorized components. Doing so will void all warranties, may impair system operation and performance, and can create hazardous conditions for service personnel and occupants. No company employee or contractor is authorized to waive this requirement.



WARNING



Only personnel trained and qualified in the installation, adjustment, servicing, maintenance, or repair of the equipment described in this manual should perform service. The manufacturer is not responsible for any injury or property damage arising from improper service or procedures. In jurisdictions where licensing is required to service this equipment, only licensed personnel should perform the service.

Improper installation, adjustment, servicing, maintenance, or repair—or attempting to perform these tasks without proper training—may result in product damage, property damage, personal injury, or death. Service personnel assume responsibility for any injury or property damage resulting from improper procedures.

TABLE OF CONTENTS

SAFETY CONSIDERATIONS	4
GENERAL	5-6
DDC CONTROLLER WIRING	7
DDC CONTROLLER I/O	8
DDC CONTROLLER OPERATIONAL CODES	9
GENERATION OF MACHINE MODE	9
MODES OF OPERATION	10
BACNET & MODBUS VARIABLES	11
CONTROLLER SOFTWARE UPDATE	12
CB1000 SERVICE TOOL	13-14
HMI MENU STRUCTURE	15-31

SAFETY CONSIDERATIONS



1. READ THE ENTIRE INSTALLATION, OPERATION, & MAINTENANCE (IOM) MANUAL BEFORE STARTING THE INSTALLATION.
2. These instructions are intended as a general guide and do not supersede national, state, or local codes in any way.
3. Any product alteration, improper installation, or use of unauthorized parts will void all warranties expressed or implied and may result in poor performance, equipment malfunction, or hazardous conditions for service personnel and occupants. Company employees or contractors are not authorized to waive this warning.
4. This product should only be installed and serviced by a qualified, licensed, and factory authorized installer or service agency.
5. All “kits” and “accessories” used must be factory authorized when modifying this product. Refer to and follow the instructions provided with each kit or accessory during installation.



RECOGNIZE THE FOLLOWING SAFETY NOTATIONS THROUGHOUT THIS MANUAL AND POSTED ON THE EQUIPMENT:



 **DANGER** 

Indicates an imminently hazardous situation which, if not avoided, will result in death or serious injury.

 **CAUTION** 

Indicates a potentially hazardous situation that may result in minor or moderate personal injury.

 **WARNING** 

 **ELECTRIC SHOCK HAZARD** 

This warning signifies potential electrical shock hazards that could result in personal injury or death.



 **IMPORTANT** 

Suggests important procedure steps to ensure proper installation, reliability, or operation.

 **WARNING** 

 **FIRE OR EXPLOSION HAZARD** 

This warning indicates potential fire or explosion hazards that could result in personal injury or death.

 **NOTE** 

Used to highlight suggestions, which may result in enhanced installation, reliability, or operation.

 **WARNING** 

Indicates a potentially hazardous situation or unsafe practice that could result in severe personal injury or death and/or damage to property.

GENERAL

This manual provides information for the Siemens DDC controller. The controller is a self-contained device capable of operating either as a stand-alone controller or as part of a networked system. Controller data and parameters may be viewed and adjusted using the keypad/display Human Machine Interface (HMI) service tool. Controller information may also be accessed through a Building Automation System (BAS) or via the controller's integrated web server interface.

For installation and startup procedures, and for general information regarding a water-source heat pump equipped with a hot gas reheat option, refer to the applicable model-specific Installation and Operation Manual (IOM).

Table 1: Installation and Maintenance Resources

Model	IOM Manual
WSV6 Series	IOM8004
WSV6 Large Series	IOM8005

Table 2: Part Number Cross-Reference

Part Description	IOM Manual
DDC Controller	CB900-1
HMI Service Tool	CB1000
Heat pump Thermostat	By others

APPLICATIONS

The CB900-2 DDC Controller supports BACnet® MS/TP and IP and Modbus IP/RTU communication protocols and is designed for water-source heat pump applications. All available energy-saving features and operating options of the water-source heat pump can be controlled by the CB900-1 DDC Controller.

The controller provides all functionality required for basic and advanced operation of water-source heat pumps. For basic operation, the CB900-2 DDC Controller may operate with a standard room thermostat (provided by others).

The controller includes outputs for control of the supply fan, compressor(s), and reversing valve, and provides additional inputs and outputs for expanded functionality.

FEATURES

- Thermostat control
- Random start
- Anti-short-cycle protection
- Compressor minimum ON/OFF timers
- High refrigerant pressure protection
- Low refrigerant pressure/Loss-of-charge protection
- High condensate level protection
- Blower delay
- Compressor delay
- Water pump / valve delay
- Up to three (3) OpCode fault-retry attempts
- Fault lockout with 24-hour retry
- Two-speed EC fan operation
- PSC fan operation

ADVANCED FEATURES

- Two-step compressor operation
- Supply air temperature monitoring

ALARMS

- High refrigerant pressure alarm
- Low refrigerant pressure alarm
- Sensor fault alarm
- Air coil low-temperature alarm
- Low leaving water temperature alarm
- Condensate detection alarm

NETWORKING CAPABILITY

- Built-in BACnet® MS/TP and IP
- Modbus IP and RTU

All operational codes and parameters are accessible via BACnet, Modbus, or the HMI Service Tool.

SERVICE AND RELIABILITY FEATURES

- Software update via USB port
- Factory-installed wiring harness connectors

PHYSICAL DATA

Power Supply

- 24 VDC ± 10%
- Max Power Input: 36W

Operating conditions

- Storage: -40.0 - 158°F [-40.0 - 70.0°C], 90% RH non-condensing
- Operating: -40.0 - 158°F [-40.0 - 70.0°C], 90% RH non-condensing

Mechanical Specifications

- Dimensions: 249 × 109 × 30.2 mm [9.8" × 4.3" × 1.2"]

GENERAL (CONTINUED)

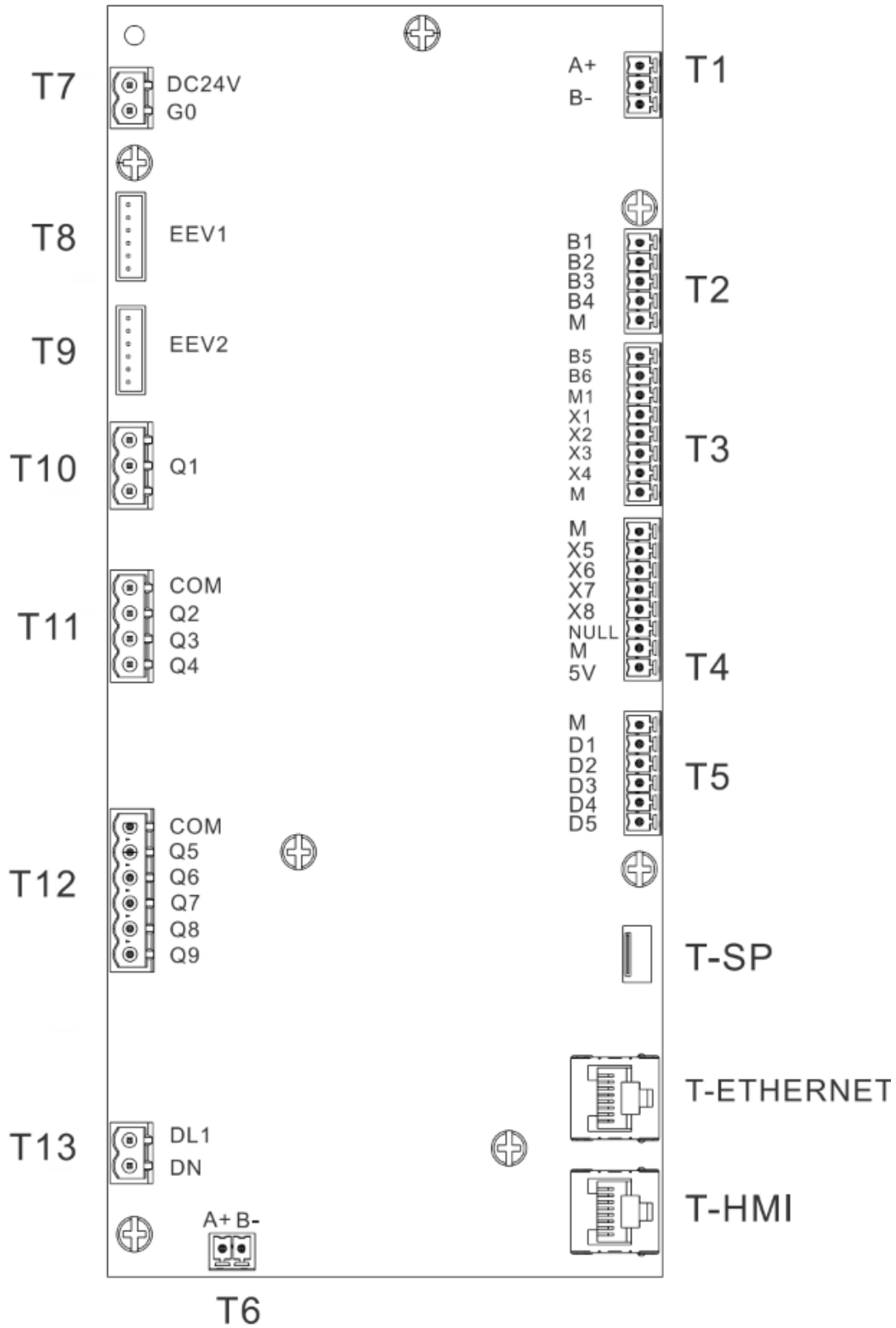

Figure 1 – Controller Connection Map

DDC CONTROLLER WIRING

Table 3: CCX Controller Wiring				
Terminal	Pole	Identifier	Wire Color	Components
T1	3	+	On-board RS 485	BMS (Field)
	2	-		
	1	Ref		
T2	5	B1	Grey	Leaving Water Temp. Sensor
	4	B2	Black	Air Coil Temperature Sensor
	3	B3	Yellow	Condensate Overflow Sensor
	2	B4	Orange	Supply Air Temp. Sensor
	1	M	Brown	Comp. Contractor Com.
T3	8	B5	NOT USED	
	7	B6		
	6	M		
	5	X1	Blue	Low Pressure Switch (NC)
	4	X2	NOT USED	
	3	X3		
	2	X4		
1	M	Brown	Com.	
T4	8	M	NOT USED	
	7	X5		
	6	X6		
	5	X7		
	4	X8		
	3	Null		
	2	M		
1	5V	Green	Low Pressure Switch (C)	
T5	6	M	NOT USED	
	5	D1	Black	High Pressure Switch (L – NO)
	4	D2	Green	Thermostat G
	3	D3	Orange	Thermostat O – Reversing Valve
	2	D4	Yellow	Thermostat Y
1	D5	NOT USED		
T6	1	A+	Extension Interface (RS485)	NOT USED
	2	B-	Red	Power Supply +Vo
T7	1	DC24V	Brown	Power Supply -Vo
	2	G0	NOT USED	NOT USED
T8	•	EEV1	NOT USED	NOT USED
T9	•	EEV2	NOT USED	NOT USED
T10	1	NC	NOT USED	NOT USED
	2	Q1-COMP	Yellow	Comp. Contractor
	3	NO	Yellow	High Pressure Switch (H – NC)
T11	1	COM	Brown	Com.
	2	Q2	Violet	Fan Motor Speed (Medium)
	3	Q3	Grey	NOT USED
	4	Q4	White	Fan Motor Speed (High)
T12	1	COM	Red	High Pressure Switch (C)
	2	Q5	Green	NOT USED
	3	Q6	Blue	NOT USED
	4	Q7	Red	NOT USED
	5	Q8	NOT USED	
	6	Q9		
T13	1	DL	NOT USED	
	2	DN		

Note(s):
Operational codes are reported via hand-held HMI, Bacnet, and Modbus.

DDC CONTROLLER I/O

SENSORS AND INPUTS

Leaving Water Temperature Sensor

A factory-installed 10 kΩ thermistor monitors the leaving water temperature.

Air Coil Temperature Sensor

A factory-installed 10 kΩ thermistor monitors the air coil refrigerant temperature.

Supply Air Temperature Sensor

Factory installed 10 kΩ thermistor is monitoring the supply air temperature.

Condensate Overflow Sensor

A factory-wired condensate overflow alarm input monitors condensate level. An alarm shall be generated when the input resistance is between 0 - 100 kΩ for 30 continuous seconds during a compressor run cycle. Upon alarm, the compressor output and supply fan shall be disabled.

Pressure Switch Status

- Low-Pressure Switch (LP)
The alarm input monitors a normally closed (NC) low-pressure switch. An alarm shall be generated when the switch remains open due to low refrigerant pressure for 30 seconds. The low-pressure switch input shall be bypassed for the first 120 seconds following compressor startup.
- High-Pressure Switch (HP)
Alarm input is monitoring the NO high pressure switch. An alarm will be generated any time the switch is closed due to high refrigerant pressure. The compressor contactor is de-energized immediately.

THERMOSTAT INPUTS

G — Fan Call

Thermostat input for fan operation. Input requires 24VAC to activate.

O — Reversing Valve Call

Thermostat input for reversing valve operation. Input requires 24VAC to activate in cool mode.

Y — Compressor Call

Thermostat input for compressor operation. Input requires 24VAC to activate.

OUTPUTS

Compressor Contactor

A 24 VAC relay output used to energize the compressor contactor.

Supply Fan — Medium Speed

A 24 VAC relay output used to energize the medium-speed tap of the supply fan motor. This is the default speed for fan-only operation.

Factory default is medium speed (violet lead). If low speed is required, remove the violet lead from the Q2 terminal and cap it. Connect the grey lead (low speed), provided capped, to the Q2 terminal.

Supply Fan — High Speed

A 24 VAC relay output used to energize the high-speed tap of the supply fan motor. The Q4 terminal may also be configured to control a water pump or valve, if applicable.

DDC CONTROLLER OPERATIONAL CODES

Table 4: DDC Controller Operational Codes	
Description Of Operation	Alarm No.
OpCode - Normal Operation	Code 11
OpCode – Lock Out – High Pressure	Code 12
OpCode – Lock Out – Low Pressure	Code 13
OpCode – Lock Out – Leaving Water Temp.	Code 14
OpCode – Lock Out – Air Coil Temp.	Code 15
OpCode – Lock Out – Condensate Detected	Code 16
OpCode – Lock Out – Swapped CO1/CO2 Thermistors	Code 18
OpCode - Lock Out - Temperature Sensors	Code 19
OpCode - Warning - Under Cooling Capacity	Code 20
OpCode - Warning - Over Cooling Capacity	Code 21
OpCode - Warning - Under Heating Capacity	Code 22
OpCode - Warning - Over Heating Capacity	Code 23
Note(s): Operational codes are reported via hand-held HMI, Bacnet, and Modbus.	

GENERATION OF MACHINE MODE

Table 5: Generation of Machine Codes						
DiagnosticEnable	MachineEnable	OpCode = 12 to 19	O	Y	G	Mode
0	0	0	X	X	0	Stand By
0	1	0	X	X	1	Fan Only
0	1	0	0	0	X	Heat
0	1	0	1	1	X	Cool
0	X	1	X	X	X	Lock Out
1	X	X	X	X	X	Diagnostic
Notes(s):						
<ul style="list-style-type: none"> • 1: True • 0: False • X: No response • Machine codes are reported via hand-held HMI, Bacnet, and Modbus. 						

MODES OF OPERATIONS

RANDOM START

The DDC Controller provides a random start delay of 10–110 seconds upon power-up.

ANTI-SHORT CYCLE PROTECTION

The DDC Controller incorporates 5-minute minimum ON and OFF anti-short-cycle protection for the compressor. The minimum ON time may be bypassed in the event of an alarm condition.

Table 6: Mode Logic Summary				
Mode	Enable Conditions	Thermostat Inputs	Controller Actions	Notes
Standby	MachineEnable = OFF or no thermostat signal	None	All outputs de-energized	Unit idle
Fan Only	MachineEnable = ON	G only	Supply fan energized at medium speed	No compressor operation
Heat	MachineEnable = ON	Y present, O not present	<ul style="list-style-type: none"> Energize water valve/pump Energize supply fan at high speed Apply random start (if enabled) Apply anti-short-cycle protection Energize compressor 	Heating operation
Cool	MachineEnable = ON	Y and O present	<ul style="list-style-type: none"> Apply anti-short-cycle protection Energize water valve/pump Energize supply fan at high speed Energize reversing valve Apply random start (if enabled) Energize compressor 	Cooling operation
Lockout	Safety fault condition	N/A	<ul style="list-style-type: none"> De-energize compressor De-energize supply fan Apply protection logic and retry delays 	Up to 3 retries
Lockout (24 hr Hold)	3 failed retries	N/A	Unit held in lockout for 24 hours	Automatic retry after hold
Permanent Lockout	3 additional failed retries after 24 hr hold	N/A	Unit remains locked out	Manual power cycle required
Diagnostic	Diagnostic mode enabled via HMI	N/A	All outputs manually controllable via HMI	Auto-exits after 5 minutes

BACNET® & MODBUS VARIABLES

Data accessible through T1 of the DDC controller (Figure 1 - Controller Connection Map). Connectors are provided with the controller. Some configurations might be required.

Table 7: Bacnet® and Modbus Variables				
BACnet Instance	Modbus Index	Variable Name	Variable Description	Type
MSV0	NA	Software Revision	Property State text: x1 x2 x3 x4. Where x1 indicates major change; x2 indicates changes involve hardware, wirings, x3 indicates software only change; x4 indicates minor changes without hardware or wiring changes	StateText[0]
BV0	0	HP Status	Status of high-pressure switch: 0-normal, 1-high pressure	Binary/Coil
BV1	1	LP Status	Status of low-pressure switch: 0-normal, 1-high pressure	Binary/Coil
AV0	0	ExitWaterCoilTemp	Exit water coil temperature in degrees F	Analog/HoldingReg
AV1	1	AirCoiltemp	Air coil temperature in degrees F	Analog/HoldingReg
BV2	2	Condensate Status	Status of condensate in drain pan (1-condensate detected, 0- not detected)	Binary/Coil
BV3	3	ReversingValue Status	Status of reversing valve (0-off, 1-on)	Binary/Coil
AV2	2	SupplyAirTemp	Supply air temperature in degree F	Analog/HoldingReg
MSV1	3	OpCode	Controller opcode, 11-OK, 12- high pressure, 13- low pressure 14- low temperature exit water, 15- low temperature of air coil, 16- condensate detected, 18- swapped temperature, 19- bad thermistor, 20-low cooling capacity, 21-high cooling capacity, 22- low heating capacity, 23-high heating capacity	MultiState/HoldingReg
BV4	4	Ysignal Status	Status of Y signal	Binary/Coil
BV5	5	Csignal Status	Status of C signal	Binary/Coil
BV6	6	Osignal Status	Status of O signal	Binary/Coil
AV3	4	3TimesLockout	Count of 3 tries before lock out	Analog/HoldingReg
MSV2	5	ModeofMachine	1-Standby, 2-FanOnly, 3-Heat, 4-Cool, 5-Cool, 7-Lock out, 8-Diagnostic	MultiState/HoldingReg
BV8	8	TestModeStatus	Test mode status. If system is in testmode, all wait times are shortened. Testmode is self-disabled after 15 min of activation	Binary/Coil
MSV3	6	FanMode	Fan status	MultiState/HoldingReg
BV10	10	CompStatus	Compressor status	Binary/Coil
MSV4	7	MachEnable	System Enable/Disable	MultiStat/HoldingReg
MSV5	NA	Program No.	Factory program number	StateText[0]
MSV6	NA	Program Rev	Factory program rev	StateText[0]
NA	11	ProgramNo1 st char	First character of factory program number (1 A, 2 B, 3 C,...)	HoldingReg
NA	12	ProgramNo 2 nd char	Second character of factory program number (1-A, 2-B, 3-C,...)	HoldingReg
NA	13	ProgramNo Numeric	Numeric part of program number (0-000, 1-001, 2-002)	HoldingReg
NA	14	Program Rev	Factory program Rev (1-A, 2-B, 3-C...)	HoldingReg
NA	15	Software Rev x1	x1 indicates major change	HoldingReg
NA	16	Software Rev x2	x2 indicates changes involve hardware wirings	HoldingReg
NA	17	Software Rev x3	x3 indicates software only change	HoldingReg
NA	18	Software Rev x4	x4 indicates minor changes without hardware or wiring changes	HoldingReg

CONTROLLER SOFTWARE UPDATE

All water-source heat pump units equipped with the DDC option are shipped with the controller fully programmed and tested. In certain cases, such as enhanced feature releases or special application requirements, a software update may be required. Software updates shall be performed via USB flash drive only.

USB REQUIREMENTS

- USB 2.0 flash drive
- Maximum capacity: 32 GB (at least 10GB recommended)
- File system: FAT or FAT32
- Drive must be empty (no other files present)

REQUIRED FILES

Copy the following uncompressed (.ucf) files to the root directory of the USB drive.

Do not rename any files.

- HMI.ucf
- HMI4Web.ucf
- HMIComp.ucf
- MBRTComp.ucf

SOFTWARE UPDATE STEPS

1. Turn OFF power to the controller.
2. Insert the USB flash drive into the USB interface on the controller.
3. Press and hold the Controller Button, then apply power to the controller.
4. Continue holding the Controller Button until the controller board LED illuminates solid red.
5. Remove power from the controller.
6. Reapply power to the controller.

Upon successful completion of the update, the controller LED shall illuminate solid green, indicating the controller is fully programmed and ready for operation.

NOTES

- Do not interrupt power during the update process.
- Use only manufacturer-approved software files.
- If the LED does not indicate solid green after completion, repeat the update procedure.

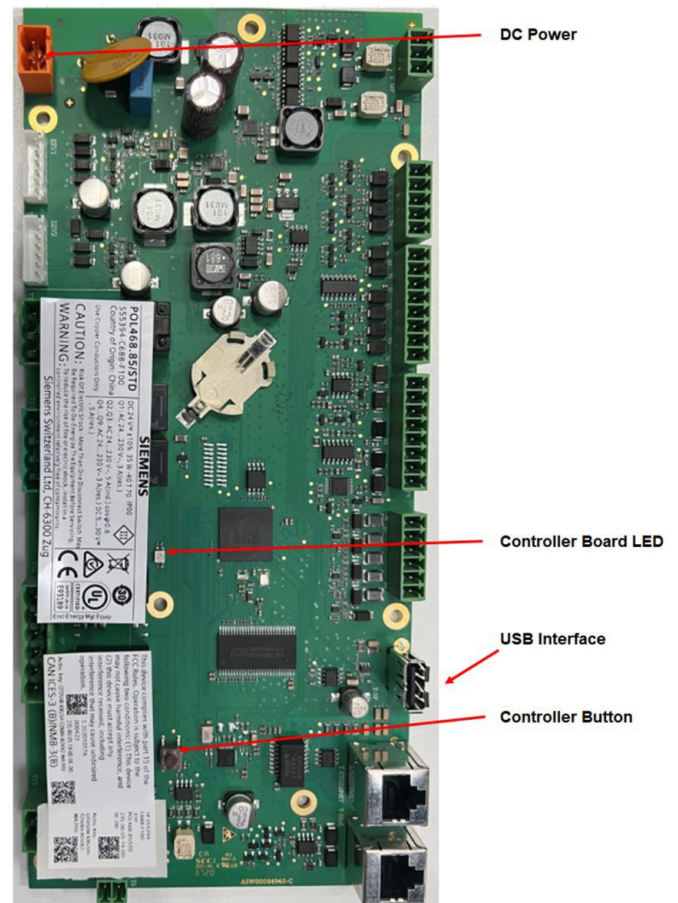

Figure 2 – Controller Software Upgrade Component Location

CB1000 SERVICE TOOL

The CB1000 is an optional service tool supplied with a 4-wire twisted-pair spiral cable terminated with a single RJ45 connector. The tool supports magnetic mounting or hand-held operation.

The CB1000 provides full access to unit operating modes, major component status, operational codes, alarms, diagnostics, and test functions.

PHYSICAL DATA

- Dimensions: 173.2 × 95.5 × 21.6 mm
- Weight: 350 g
- Cable Length: 2.5 m (extended)

OPERATING CONDITIONS

- Temperature: -40.0 – 158°F [-40.0 - 70.0°C]
- Humidity: 5% to 95% RH, non-condensing



Figure 3 – CB1000 HMI Service Tool

CONNECTION AND POWER

The CB1000 HMI Service Tool is powered directly by the controller through the local HMI connection. Connect the CB1000 RJ45 connector to the T-HMI port on the controller (refer to **Figure 1 – Controller Connection Map**).

Upon initial connection, the CB1000 will automatically download the required program and menu data from the controller. This process may take several minutes. When the download is complete, the Main Overview screen will be displayed.

Table 8: CB1000 Function Keys		
Key Name	Operation	Description
UP	Press	• To increase the input value
	Press and hold	• To enable the acceleration function to increase the value to a large extent
DOWN	Press	• To decrease the input value
	Press and hold	• To enable the acceleration function to decrease the value to a large extent
ENTER	Press	• To select one item • To confirm selection
	Press and hold	• To enter password
INFO	Press	• To go to home page
ALARM	Press	• To activate and switch to alarm page
ESC	Press	• To cancel modification • To exit to upper level of menu or back to previous page
	Press and hold	• To go to home page

CB1000 SERVICE TOOL (CONTINUED)

CONNECTION AND POWER (CONTINUED)

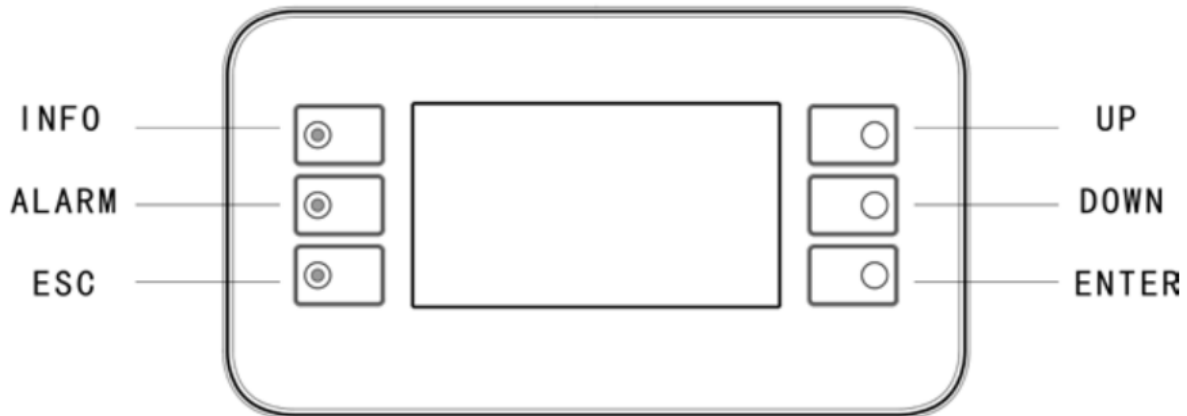

Figure 4 – CB1000 Function Keys

The 93.0 × 58.0 mm LCD display presents menu pages consisting of multiple lines. Each line displays either status-only information or adjustable data fields.

When the cursor is positioned on a status-only line, the line is highlighted with blue text enclosed by a white box. When the cursor is positioned on a line containing an adjustable data field (other than ►), press ENTER to select the field. The selected field will be highlighted. Use the UP or DOWN buttons to modify the value, then press ENTER to confirm the selection.

If the adjustable data field is indicated by ►, pressing ENTER will open the corresponding submenu page.

Press ESC to return to the previous menu page or to move back one menu level.

LOGIN

The LOGIN page allows the user to enter a password to access higher-level menu functions. Password levels determine which pages and parameters are available.

- Level 1: No password required (basic access)
- Level 2: Password protected
- Level 3: Password protected (highest access level)

When no password is entered, the user operates at Level 1 and has access only to basic status menu items.

To access the LOGIN page and enter a password, press and hold the ENTER button for 10 seconds from any screen.



Figure 5 – Login Page

Use the UP or DOWN button to change the value of the current digit. Press ENTER to accept the digit and advance to the next position. All four digits must be entered to complete the login process.

If an invalid password is entered, access will be denied. Re-enter the correct password or press and hold the ESC button to exit the LOGIN screen.

After a valid password has been entered, press and hold the ENTER button for more than 10 seconds to log off and return to the default access level.

The current access level is indicated on all screens by a key icon displayed in the upper-right corner:

- Level 1: No key icon (blank)
- Level 2: Two key icons
- Level 3: Three key icons

Password Definitions:

- Level 1: No password required
- Level 2: 8273
- Level 3: Contact the manufacturer for access credentials

HMI MENU STRUCTURE

This section describes the menu structure of the CB1000 HMI Service Tool. All menus and menu items are displayed on the LCD screen. The availability of specific menu items is dependent on the active password access level.

When the CB1000 HMI Service Tool is connected to the controller, it automatically downloads the application program and menu structure from the controller. This process may take several minutes. Upon successful completion, the Main Overview page is displayed.

MAIN OVERVIEW

The Main Overview menu provides basic software, firmware, and program information. Items displayed in this menu are listed in **Table 9: Main Overview Menu Items**.

Table 9: Main Overview Menu Items			
Menu Item	Type	Description	Password Level
HydroTech	Selectable	Navigates to the HydroTech page (see Table 10: HydroTech Menu).	None
SoftwareRev	Status Only	Displays the current software revision.	
ProgramNo	Status Only	Displays the program number.	
ProgramRev	Status Only	Displays the program revision.	

HMI MENU STRUCTURE (CONTINUED)

HYDROTECH (PAGE)

Items on the HydroTech page (**Table 10: HydroTech Menu**) provide access to basic unit operating status, diagnostic functions, and configuration settings.

Table 10: HydroTech Menu					
Menu Item	Type	Description	Range	Access Level	
ModeOfMachine	Status Only	Displays the current operating mode of the unit.	Standby	Level 1	
			Fan Only		
			Heat		
			Cool		
			Lock Out		
			Diagnostic		
OpCode	Status Only	Displays the current operation code.	11 - 23	Level 1	
MachineEnable	Selectable	Displays the machine enable status. Press ENTER, then use UP/DOWN to change the value and press ENTER to confirm.	On/Off		
Status	Selectable	Navigates to the Status page (see Table 11: Status Definitions).	-		
Diagnostic	Selectable	Navigates to the Diagnostic page (see Table 12: Diagnostic Menu).	-		Level 2 or 3
Setting	Selectable	Navigates to the Setting page (see Table 13: Settings Menu).	-		Level 2 or 3

HMI MENU STRUCTURE (CONTINUED)

STATUS (PAGE)

Items on the Status page (**Table 11: Status Definitions**) display real-time component operating status and sensor values. This page is read-only.

Table 11: Status Definitions				
Menu Item	Type	Description	Range	Access Level
ModeOfMachine	Status Only	Displays the current operating mode of the unit. Refer to Table 5: Generation of Machine Codes for mode definitions.	Standby	Level 1
			Fan Only	
			Heat	
			Cool	
			Lock Out	
			Diagnostic	
TestModeEnable	Selectable	Indicates test mode status. When set to ON, compressor wait times are shortened. Test mode is active for 15 minutes.	On/Off	Level 1
Y Signal	Status Only	Indicates the compressor call signal from the thermostat.	On/Off	
O Signal	Status Only	Indicates the cooling call signal from the thermostat.	On/Off	
G Signal	Status Only	Indicates the fan call signal from the thermostat.	On/Off	
CompressorStatus	Status Only	Indicates the status of the compressor contactor.	On/Off	
FanMode	Status Only	Indicates the current fan operating speed.	Low/High	
ExitWaterTemp (CO1)	Status Only	Displays the leaving water temperature.	-	
AirCoilTemp (CO2)	Status Only	Displays the indoor air coil temperature.	-	
SupplyAirTemp	Status Only	Displays the discharge / supply air temperature.	-	
HighPressureSwitch	Status Only	Indicates the status of the high refrigerant pressure switch fault.	On/Off	
LowPressureSwitch	Status Only	Indicates the status of the low refrigerant pressure switch fault.	On/Off	
CondensateRes	Status Only	Displays the resistance value of the condensate overflow sensor.	0 - 60 kΩ	
CondensateStatus	Status Only	Indicates the condensate overflow fault status.	OK/Fault	
OpCode	Status Only	Displays the current operation code. Refer to Table 4: DDC Controller Operational Codes for definitions.	11 - 23	
3TriesLockOut	Status Only	Displays the number of fault retry attempts. When the value reaches 3, the unit enters lockout mode. A hard restart (power cycle) is required.	0.0	
			1.0	
			2.0	
			3.0	

HMI MENU STRUCTURE (CONTINUED)

DIAGNOSTIC (PAGE)

Items on the Diagnostic page (**Table 12 – Diagnostic Menu**) provide access to diagnostic and troubleshooting status and selectable test functions.

Access to this page requires password Level 2 or Level 3.

Table 12: Diagnostic Menu					
Item	Type	Description / Function	Default Setting	Range	Password Level
DiagnosticEnable	Selectable	Enables diagnostic mode. Default is OFF. When set to ON, diagnostic mode is active for 15 minutes. While enabled, normal enable functions (including CpFnhVlvPmpEnable and FanLowEnable) are turned OFF to allow individual component troubleshooting.	Off	On/Off	Level 2, 3
CpFnhVlvPmpEnable	Selectable	Energizes the compressor, high-speed fan, and water pump/valve. DiagnosticEnable must be ON to modify. Use ENTER, then UP/DOWN, and ENTER to confirm.	Off	On/Off	
CompressorStatus	Status Only	Indicates the status of the compressor contactor.	Off	On/Off	
FanModeStatus	Status Only	Indicates the current fan operating speed.	High	High/Low	
FanLowEnable	Selectable	Energizes the low-speed fan. DiagnosticEnable must be ON to modify. Use ENTER, then UP/DOWN, and ENTER to confirm.	Off	On/Off	
WaterTemp (CO1)	Status Only	Displays the leaving water temperature.	-	-	
AirCoilTemp (CO2)	Status Only	Displays the indoor air coil temperature.	-	-	
CondensateStatus	Status Only	Indicates the status of the condensate overflow sensor fault.	-	-	
SupplyAirTemp	Status Only	Displays the discharge/supply air temperature.	-	-	

HMI MENU STRUCTURE (CONTINUED)

SETTING (PAGE)

Items on the Setting page (**Table 13: Settings Menu**) allow modification of unit configuration parameters and control settings.

Access to this page requires password Level 2 or Level 3.

Table 13: Settings Menu					
Item	Type	Description / Function	Default Setting	Range	Password Level
Communication	Selectable	Navigates to the Communication page for configuration of BACnet / Modbus parameters (see Table 14: Communication Menu).	-	Passive Active	Level 2, 3
ImperialEngSystem	Selectable	Sets the unit system. Default is SI (°C). Select ACTIVE to switch to IP (°F). A soft restart is required to convert internal parameters. Use Restart → Execute to apply changes.	Passive	Passive Active	
ParameterSave	Selectable	Saves current controller parameter settings to a USB flash drive. With a USB drive inserted, select ACTIVE to upload parameters.	Passive	Passive Active	
ParaSaveSuccessful	Status Only	Indicates status of the parameter save operation. YES = save successful. NO = repeat ParameterSave.	No	Yes/No	
ParameterLoad	Selectable	Loads parameter settings from a USB flash drive into the controller. With a USB drive inserted, select ACTIVE to load parameters.	Passive	Passive Partial Full	
ParaLoadSuccessful	Status Only	Indicates status of the parameter load operation. YES = load successful. NO = repeat ParameterLoad.	No	Yes/No	
AdvancedSetting	Selectable	Navigates to Advanced Communication and Authorization settings (see Table 18: Modbus RTU Definitions).	-	-	Level 3 only
FactoryReset	Selectable	Resets all field-configured parameters to factory default values. Select ON and press ENTER to execute.	Off	On/Off	
Restart	Selectable	Performs a soft restart of the controller. Select Execute to apply. Restart is required after any parameter changes.	-	-	Level 2, 3

HMI MENU STRUCTURE (CONTINUED)

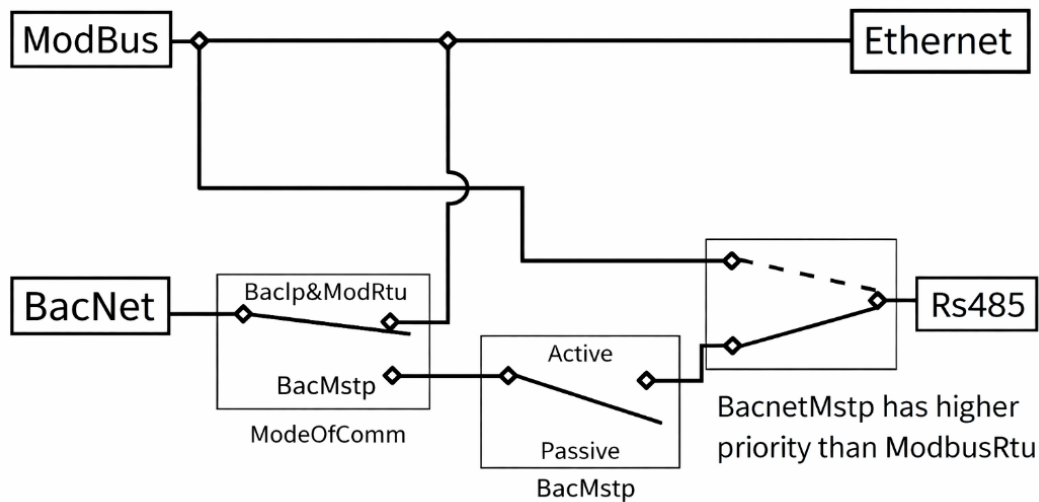

Figure 6 – Setting Mode of Communications

COMMUNICATION (PAGE)

Items on the Communication page (Table 14: Communication Menu) provide access to selectable parameters and status information for BACnet and Modbus communication settings. Access to this page requires password Level 2 or Level 3.

Table 14: Communication Menu					
Item	Type	Description / Function	Default Setting	Range	Access Level
IpConfig	Selectable	Navigates to the IPConfig page for configuration of IP communication parameters (see Table 15: IPConfig Definitions).	BacIP & ModRTU	BacIP & ModRTU BacMSTP	Level 2, 3
ModeOfComm	Selectable	Sets the communication mode. Options include:	Active	Active	Level 3
		<ul style="list-style-type: none"> BacIp&ModRtu – Enables BACnet IP and Modbus RTU BacNetMstp – Enables BACnet MS/TP BACnet MS/TP must be set to ACTIVE (Level 3; default setting).		Passive	
BacNetMstp	Selectable	Enables BACnet MS/TP communication.	Active	-	Level 3
		<ul style="list-style-type: none"> Modbus IP is always available. BACnet IP and BACnet MS/TP cannot be active simultaneously. Modbus RTU and BACnet MS/TP cannot be active simultaneously. 			
BacnetMstpSetting	Selectable	Navigates to BACnet MS/TP parameter settings (see Table 17: BACnet MS/TP Definitions).	-	-	Level 2, 3
ModbusRtuSetting	Selectable	Navigates to Modbus RTU parameter settings (see Table 18: Modbus RTU Definitions).	-	-	
Restart	Selectable	Performs a soft restart of the controller. Select Execute to apply. Restart is strongly recommended after modifying communication parameters.	-	-	

HMI MENU STRUCTURE (CONTINUED)

IPCONFIG (PAGE)

Items on the IPConfig page (**Table 15: IPConfig Definitions**) provide access to selectable parameters and status information for Internet Protocol (IP) configuration settings.

Table 15: IPConfig Definitions					
Item	Type	Description / Function	Default Setting	Access Level	Notes
DHCP	Selectable	Sets DHCP mode: <ul style="list-style-type: none"> ACTIVE (Dynamic): Network assigns IP address automatically PASSIVE (Static): Allows manual IP configuration 	Passive	Level 2, 3	Soft restart required
IP Address	Selectable	Sets the controller IP address. DHCP must be PASSIVE. Edit each digit using UP/DOWN, press ENTER to advance.	192.168.1.42		Soft restart required
Subnet Mask	Selectable	Sets the subnet mask. DHCP must be PASSIVE. Edit per digit using UP/DOWN and ENTER.	255.255.255.0		Soft restart required
Default Gateway	Selectable	Sets the default gateway. DHCP must be PASSIVE. Edit per digit using UP/DOWN and ENTER.	192.168.1.1		Soft restart required
Preferred DNS Server	Selectable	Sets the preferred DNS server. DHCP must be PASSIVE. Edit per digit using UP/DOWN and ENTER.	194.25.2.129		Soft restart required
Alternate DNS Server	Selectable	Sets the alternate DNS server. DHCP must be PASSIVE. Edit per digit using UP/DOWN and ENTER.	194.25.2.130		Soft restart required
Host Name	Status Only	Displays the current host name.	POL468_0D0C7A		Read-only
MAC Address	Status Only	Displays the controller MAC address.	00-05-19-0D-0C-7A		Read-only
Link	Status Only	Indicates network link status.	Passive		Read-only
100 Mbit	Status Only	Indicates 100 Mbps link speed status.	Passive		Read-only
Advanced	Selectable	Allows more advance Climatix configuration parameters. Press ENTER button will lead to IP-Config page.	-		
Restart Required*	Selectable	Performs a soft restart after parameter changes. Restart → Execute to apply changes.	-		Required after configuration changes

Note(s):

* A soft restart is required to save all setting changes.

HMI MENU STRUCTURE (CONTINUED)

AIP-CONFIG PAGE (ADVANCED IP-CONFIG)

The **aIP-Config** page (Table 16: **aIP-Config Configuration**) contains settings for advanced administrative functions related to IP network communications.

Use the **ENTER**, **UP**, and **DOWN** buttons to view or modify settings.

Table 16: aIP-Config Configuration					
Item	Type	Description	Default Setting	Range	Access
Tool Access	Selectable	Enables or disables external tool access for IP communication.	Passive	Active / Passive	Level 3
Port	Selectable	Communication port used for tool access.	4242	0 – 65535	
Authorization	Selectable	Password required to authorize tool access.	—	—	
User Name	Selectable	Administrator account user name for network access.	ADMIN	—	
Password	Selectable	Administrator account password for network access.	—	—	
Web HMI (HTTP)	Selectable	Enables or disables browser-based Web HMI access.	Active	Active / Passive	
Port	Selectable	Communication port used for Web HMI access.	80	0 – 65535	
User Name	Selectable	User name required to access the Web HMI interface.	WEB	—	
Password	Selectable	Password required to access the Web HMI interface.	—	—	
FTP	Selectable	Enables or disables FTP (File Transfer Protocol) access.	Active	Active / Passive	
Port	Selectable	Communication port used for FTP connections.	21	0 – 65535	
User Name	Selectable	User name required for FTP access.	ADMIN	—	
Password	Selectable	Password required for FTP access.	—	—	
TFTP	Selectable	Enables or disables TFTP (Trivial File Transfer Protocol).	Passive	Active / Passive	
Port	Selectable	Communication port used for TFTP connections.	69	0 – 65535	
Mapping	Selectable	Port used for JSON data communication and mapping.	19384	0 – 65535	
User Name	Selectable	User name required for JSON communication access.	JSON	—	
Password	Selectable	Password required for JSON communication access.	—	—	
Port Idle Timeout	Selectable	Sets the communication port idle timeout period.	3600 s	0 s – 65535 s	
Restart Required*	Selectable	Performs a soft restart after parameter changes. Restart → Execute to apply changes.	—	—	

HMI MENU STRUCTURE (CONTINUED)

BACNETMSTPSETTING (PAGE)

Items on the BacNetMstpSetting page (**Table 17: BACnet MS/TP Definitions**) provide access to selectable configuration parameters for BACnet MS/TP communication.

Table 17: BACnet MS/TP Definitions						
Item	Type	Description / Function	Default Setting	Range	Access Level	Notes
CommBaudRate	Selectable	Sets the BACnet MS/TP communication baud rate. Press ENTER, use UP/DOWN to select the desired baud rate, then press ENTER to confirm.	38,400	9,600	Level 2, 3	Soft restart required
				19,200		
				38,400		
				57600		
				115200		
DeviceAddress	Selectable	Sets the device address (ID) for BACnet and Modbus. For BACnet MS/TP, valid range is 0–127. Use UP/DOWN to adjust the value and ENTER to confirm.	9.0	0.0 - 254.0	Level 2, 3	Soft restart required
MaxMaster	Selectable	Sets the maximum master address on the BACnet MS/TP network. Use UP/DOWN to adjust and ENTER to confirm.	127.0	0.0 - 127.0		Soft restart required
MaxInfoFrame	Selectable	Sets the maximum information frames parameter for BACnet MS/TP communication. Use UP/DOWN to adjust and ENTER to confirm.	10.0	1.0 - 32.0		Soft restart required
Restart Required*	Selectable	Performs a soft restart after parameter changes. Restart → Execute to apply changes.	-	-		Required after configuration changes

Note(s):

* A soft restart is required to save all setting changes.

MODBUSRTUSETTING (PAGE)

Items on the ModBusRtuSetting page (**Table 18: Modbus RTU Definitions**) provide access to selectable configuration parameters for Modbus RTU (Remote Terminal Unit) communication.

Table 18: Modbus RTU Definitions						
Item	Type	Description / Function	Default Setting	Range	Access Level	Notes
CommBaudRate	Selectable	Sets the Modbus RTU communication baud rate. Press ENTER, use UP/DOWN to select the desired baud rate, then press ENTER to confirm.	38400	9600	Level 2, 3	Soft restart required
				19200		
				38400		
				57600		
				115200		
DeviceAddress	Selectable	Sets the Modbus RTU device address. Valid range is 1–247. Use UP/DOWN to adjust the value and press ENTER to confirm.	9.0	1 - 247	Level 2, 3	Soft restart required
ModBusParity	Selectable	Sets the Modbus parity. Press ENTER, use UP/DOWN to select the desired parity, then press ENTER to confirm.	None	Even		Soft restart required
				Odd		
				None		
ModBusStopBit	Selectable	Sets the Modbus stop bit. Press ENTER, use UP/DOWN to select the desired stop bit, then press ENTER to confirm.	1StopBit	1StopBit	Level 2, 3	Soft restart required
				2StopBit		
Restart Required*	Selectable	Performs a soft restart after parameter changes. Restart → Execute to apply changes.	-	-		Required after configuration changes

Note(s):

* A soft restart is required to save all setting changes.

HMI MENU STRUCTURE (CONTINUED)

COMMUNICATION OVERVIEW (PAGE)

Items on the Communication Overview page (**Table 19: Communication Overview Definitions**) provide selectable options and status information for communication parameters. Access to this section requires Network Administrator knowledge and authorization. Password Level 3 is required to view or modify items on this page. Contact the manufacturer to obtain Level 3 access credentials.

The 100 Mbit item is status-only and indicates the current 100-Mbit network link status.

Table 19: Communication Overview Definitions				
Item	Type	Description / Function	Default Setting	Access Level
Comm.module overview	Selectable	Navigates to the Communication Module Overview page.	—	Level 3
IP-Config	Selectable	Displays status of IP (Internet Protocol) configuration parameters. Press ENTER to navigate to the IP-Config page (see Table 15: IP-Config).	—	
IP Address	Status Only	Displays the current IP address.	192.168.1.42	
Host Name	Status Only	Displays the current device host name.	POL468_0D0C7A	
WLAN-Config	Selectable	Displays status of WLAN (Wireless LAN) configuration parameters. Press ENTER to navigate to the WLAN-Config page (see Table 21 – WLAN-Config).	AccessPoint	
Gateway	Status Only	Displays the current default gateway.	0.0.0.0	
Modbus RTU (RS485)	Selectable	Displays status of Modbus RTU (RS485) communication parameters. Press ENTER to navigate to the Modbus RTU page (see Table 18: Modbus RTU Definitions).	—	
Climatix IC	Selectable	Displays status of Climatix IC remote monitoring and diagnostic parameters. Press ENTER to navigate to the CSL-Config page (see Table 22: CSL-Config).	—	
BACnet	Selectable	Displays status of BACnet communication parameters. Press ENTER to navigate to the BACnet settings page (see Table 15: IPConfig Definitions).	OK	
Authorization	Status Only	Displays the authorization status (masked).	—	
100 Mbit	Status Only	Indicates 100 Mbps Ethernet link status.	—	

Note(s):

1. All items on this page require Network Administrator knowledge
2. Password Level 3 access is required
3. Contact the manufacturer for Level 3 credentials

HMI MENU STRUCTURE (CONTINUED)

COMM.MODULE OVERVIEW (PAGE)

Items in Comm.module overview page contains the selectable reminder that soft restart is required after modification of parameters. To restart, move the cursor to Restart required!, press the ENTER button, select Execute and press the ENTER button.

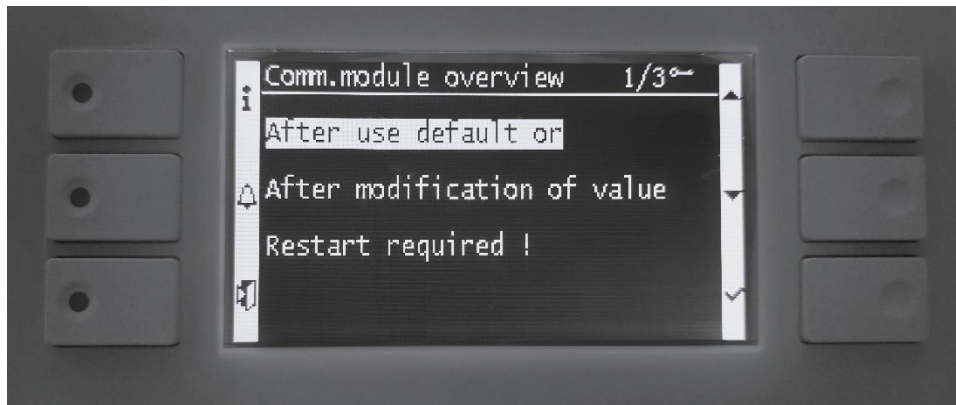

Figure 7 - Comm.module Overview

WLAN-CONFIG (PAGE)

Items on the WLAN-Config page (**Table 20: WLAN-Config**) provide selectable options and status information for WLAN (wireless local area network) configuration parameters. Access to this section requires Network Administrator knowledge and authorization. Password Level 3 is required to view or modify items on this page. Contact the manufacturer to obtain Level 3 access credentials.

Table 20: WLAN Configuration					
Item	Type	Description / Function	Default Setting	Range	Access Level
Mode	Status Only	Displays the current WLAN operating mode.	—	—	Level 3
DHCP	Status Only	Displays the current DHCP (Dynamic Host Configuration Protocol) status.	Active	Active / Passive	
IP Address	Status Only	Displays the current IP address assigned to the WLAN interface.	—	—	
Subnet Mask	Status Only	Displays the current client subnet mask.	—	—	
Default Gateway	Status Only	Displays the current default gateway.	—	—	
Preferred DNS Server	Status Only	Displays the current preferred DNS (Domain Name System) server.	—	—	
Alternate DNS Server	Status Only	Displays the current alternate DNS (Domain Name System) server.	—	—	
MAC Address	Status Only	Displays the MAC (Media Access Control) address of the WLAN interface.	—	—	
Advance	Selectable	Navigates to advanced WLAN configuration parameters. Press ENTER to open the aWLAN-Config page (see Table 21: aWLAN-Config).	—	—	

Note(s):

* A soft restart is required to save all setting changes.

HMI MENU STRUCTURE (CONTINUED)

AWLAN-CONFIG (ADVANCED WLAN-CONFIG PAGE)

Items on the aWLAN-Config page (**Table 21: aWLAN-Config**) provide access to selectable advanced WLAN configuration parameters. Access to this section requires Network Administrator knowledge and authorization. Password Level 3 is required to view or modify items on this page. Contact the manufacturer to obtain Level 3 access credentials.

Table 21: aWLAN Configuration					
Item	Type	Description / Function	Default Setting	Range	Access Level
USB Power	Selectable	Enables or disables USB power. Press ENTER, use UP/DOWN to select Yes or No, then press ENTER to confirm.	Yes	Yes / No	Level 3
Enable	Selectable	Enables or disables WLAN mode. Press ENTER, use UP/DOWN to select Yes or No, then press ENTER to confirm.	Yes	Yes / No	
Tool Enable	Selectable	Enables or disables Tool access over WLAN. Press ENTER, use UP/DOWN to select Yes or No, then press ENTER to confirm.	Yes	Yes / No	
HTTP Enable	Selectable	Enables or disables HTTP (Hypertext Transfer Protocol) access over WLAN. Press ENTER, use UP/DOWN to select Yes or No, then press ENTER to confirm.	Yes	Yes / No	
Restart Required*	Selectable	Performs a soft restart after parameter changes. Restart → Execute to apply changes.	—	—	

Note(s):

* A soft restart is required to save all setting changes.

HMI MENU STRUCTURE (CONTINUED)

CSL-CONFIG

Items on the CSL-Config page (**Table 22: CSL-Config Configuration**) provide access to selectable options and status information for Climatix configuration parameters. Access to this section requires Network Administrator knowledge and authorization. Password Level 3 is required to view or modify items on this page. Contact the manufacturer to obtain Level 3 access credentials.

Table 22: CSL Configuration					
Item	Type	Description / Function	Default Setting	Range	Access Level
Enable	Selectable	Enables or disables the Climatix configuration function. Press ENTER, select the desired value using UP/DOWN, then press ENTER. Press ESC to return to the previous page.	—	Disable	Level 3
				Deprecated	
				Enable	
Serial number	Status Only	Displays the controller serial number.	—	—	
Activation key	Status Only	Displays the controller activation key.	—	—	
Communication	Status Only	Displays the status of Climatix communication.	—	—	
Cloud server	Status Only	Displays the status of the Climatix cloud server connection.	—	—	
Tenant key	Selectable	Sets the tenant key. Move the cursor to the required character or digit, adjust using UP/DOWN, and press ENTER to confirm.	—	Alphanumeric	
Upgrade allowed	Selectable	Enables or disables permission for software upgrades. Press ENTER, select the desired value, and press ENTER.	—	Yes	
				No	
				Wait	
Upgrade request	Selectable	Requests or cancels a software upgrade. Press ENTER, select Active or Passive, and press ENTER.	—	Active	
				Passive	
Advance	Selectable	Navigates to advanced Climatix configuration parameters.	—	—	
Application info	Selectable	Displays application-specific information.	—	—	

HMI MENU STRUCTURE (CONTINUED)

ACSL-CONFIG (ADVANCED CSL-CONFIG PAGE)

Items in the aCSL-Config page (**Table 23: aCSL Configuration**) provide selectable and status information for advanced Climatix configuration parameters. Access to this page requires Network Administrator knowledge and authorization. Password Level 3 access is required. Contact the manufacturer to obtain the appropriate password.

Table 23: aCSL Configuration						
Item	Type	Description / Function	Default Setting	Range	Access Level	Notes
Server name/IP adr.	Status Only	Displays the configured Climatix server name or IP address.	Disable	—	Level 3	Read-only parameter.
Min. send interval	Selectable	Sets the minimum data transmission interval to the Climatix server. Use UP/DOWN to adjust and ENTER to confirm.	30 sec	0 - 65,535 sec		ESC returns to previous page.
Reconnect time	Selectable	Sets the time delay before attempting to reconnect to the Climatix server after a communication loss.	15 sec	0 - 65,535 sec		ESC returns to previous page.
Communication	Selectable	Sets the communication port used for Climatix data exchange.	16,384	0 - 65,535 sec		ESC returns to previous page.
Possible languages	Selectable	Displays available language options when supported.	—	—		Availability depends on firmware.
Certificate SSL	Selectable	Configures SSL certificates for secure communication. Available options include Domain, Time, Selfsigned, and RootCA. Multiple selections are allowed.	—	Domain		Select items, then choose Done to confirm.
				Time		
				Selfsigned		
				RootCA		
Options	Selectable	Configures Climatix options.	NA (0x0000)	NA (0x0000)	Changes applied after selection.	
				RTA		
Idle timeout RTA	Selectable	Sets the idle timeout for RTA communication.	3,600 sec	0 - 65,535 sec		—

HMI MENU STRUCTURE (CONTINUED)

APPLICATION INFO (ADVANCED APPLICATION INFO PAGE)

Items in the aApplication info page (**Table 24: aApplication Configuration**) provide selectable and status information related to application details. Access to this page requires Network Administrator knowledge and authorization. Password Level 3 access is required. Contact the manufacturer to obtain the appropriate password.

Table 24: aApplication Configuration					
Item	Type	Description / Function	Default Setting	Range	Access Level
Plant info	Selectable	Sets the plant identification information. Move the cursor to the first character, press ENTER, adjust characters using UP/DOWN, and press ENTER to confirm. Press ESC to advance or return.	POL6x8	Alphanumeric	Level 3
Site name	Selectable	Sets the site name associated with the application. Edit characters individually using ENTER and UP/DOWN.	#	Alphanumeric	
Street	Selectable	Sets the street address (number and street name). Characters are edited individually using ENTER and UP/DOWN.	#	Alphanumeric	
City	Selectable	Sets the city associated with the application address. Characters are edited individually using ENTER and UP/DOWN.	#	Alphanumeric	

HMI MENU STRUCTURE (CONTINUED)

BACNET (PAGE)

Items in the BACnet page (**Table 25: BACnet Configuration**) provide selectable and status information for BACnet (Building Automation and Control Network) configuration parameters. Access to this page requires Network Administrator knowledge and authorization. Password Level 3 access is required. Contact the manufacturer to obtain the appropriate password.

Table 25: BACnet Configuration					
Item	Type	Description / Function	Default Setting	Range	Access Level
Application state	Status Only	Displays the current BACnet application state.	—	—	Level 3
Device name	Selectable	Sets the BACnet device name. Move the cursor to the first character, press ENTER, adjust using UP/DOWN, and press ENTER to confirm each character. Press ESC to return.	—	Alphanumeric	
Device ID	Selectable	Sets the BACnet device ID. Press ENTER, select the desired value using UP/DOWN, and press ENTER to confirm.	1,098,746	0 - 4,194,302	
TCP/IP	Selectable	Enables or disables BACnet TCP/IP communication. Select Active or Passive using UP/DOWN, then press ENTER.	Passive	Active Passive	
Port	Selectable	Sets the BACnet TCP/IP communication port. Press ENTER, adjust using UP/DOWN, and press ENTER to confirm.	47,800	0 - 65,535	
RS485-2	Selectable	Enables or disables BACnet RS485-2 communication. Select Active or Passive using UP/DOWN, then press ENTER.	Active	Active Passive	
MS/TP address	Selectable	Sets the BACnet RS485-2 MS/TP device address.	9	0 - 255	
Baud rate	Selectable	Sets the BACnet RS485-2 communication baud rate.	38,400	9,600 - 49,664	
Max master	Selectable	Sets the BACnet RS485-2 Max Master value.	127	0 - 127	
Max. info frames	Selectable	Sets the BACnet RS485-2 maximum number of information frames.	10	0 - 32	
Advanced	Selectable	Navigates to advanced BACnet configuration parameters.	—	—	
Database revision	Status Only	Displays the current BACnet database revision.	1	—	
Config CRC	Status Only	Displays the current configuration CRC value.	39,801	—	
Restart BACstac	Selectable	Restarts the BACnet stack. Select Execute to perform the restart.	—	Execute	
Restart Required*	Selectable	Performs a soft restart after parameter changes. Restart → Execute to apply changes.	—	—	

Note(s):

* A soft restart is required to save all setting changes.

HMI MENU STRUCTURE (CONTINUED)

ABACNET (ADVANCED BACNET PAGE)

Items in the aBACnet page (**Table 26: aBACnet Configuration**) provide selectable and status information for advanced BACnet (Building Automation and Control Network) configuration parameters. Access to this page requires Network Administrator knowledge and authorization. Password Level 3 access is required. Contact First Co. to obtain the appropriate password.

Table 26: aBACnet Configuration					
Item	Type	Description / Function	Default Setting	Range	Access Level
Foreign device	Selectable	Enables or disables the BACnet foreign device function. Select the desired value using UP/DOWN, press ENTER to confirm, and press ESC to return.	Passive	Passive	Level 3
				Active	
BBMD IP	Selectable	Sets the BACnet foreign device BBMD (Broadcast Management Device) IP address or broadcast smuggler address.	0.0.0.0	IP Address	
BBMD Port	Selectable	Sets the BACnet foreign device BBMD router port.	47,808	0 - 65,535	
Timeout	Selectable	Sets the BACnet Application Protocol Data Unit (APDU) timeout.	6,000 ms	1000 - 60,000 ms	
Segm. timeout	Selectable	Sets the BACnet APDU segmentation timeout.	5,000 ms	500 - 60,000 ms	
Max. length	Selectable	Sets the maximum BACnet APDU message length.	480	50 - 1024	
Number of retries	Selectable	Sets the number of BACnet APDU retry attempts.	3	0 - 65,535	
Segm. support	Selectable	Sets BACnet segmentation support mode.	Transmit	Transmit	
				Receive	
				Both	
				No	
Max. segments	Selectable	Sets the maximum number of BACnet segments supported.	4	2 - 8	
Character set	Selectable	Sets the BACnet character encoding format.	ANSI/UTF-8	Auto	
				ANSI/UTF-8	
				ISO-8859-1	
				UCS-2	
Mapping	Selectable	Sets the BACnet object mapping value.	16,384	0 - 65,535	
Security level	Selectable	Sets the BACnet security level.	0	0 - 65,535	

NOTES



P.O. Box 270969 Dallas, TX 75227
www.firstco.com or www.ae-air.com

The manufacturer works to continually improve its products. It reserves the right to change design and specifications without notice.

©2026 First Co., Applied Environmental Air