

Installation, Operation, & Maintenance Manual

IOM8004
Rev. B 03/26

WSV6 009-072 VERTICAL SERIES WATER SOURCE HEAT PUMP

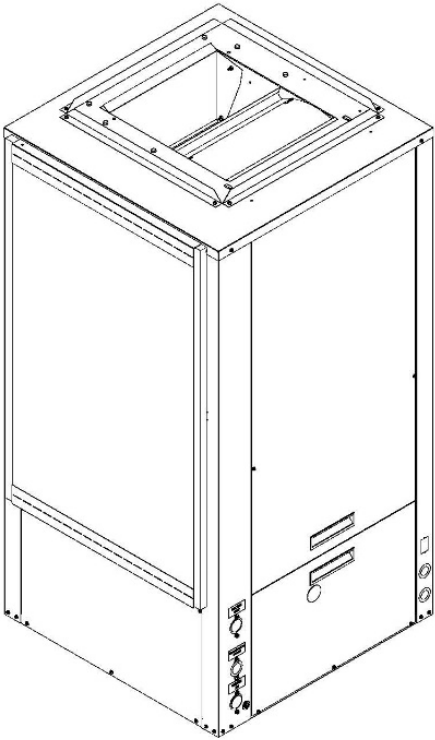

COPYRIGHT

In accordance with its policy of continuous product improvement, First, Co. and AE Air reserve the right to modify, change, or discontinue specifications or designs at any time without notice and without incurring obligation.

The warranty may be void unless the Startup & Performance Checklist is completed and returned to the warrantor. If the HVAC unit is not installed properly, the warranty will be void, as the manufacturer cannot be held accountable for problems that stem from improper installation.

©2026 First Co. / AE-Air, 8273 Moberly Lane, Dallas, TX 75227



WARNING



Do NOT modify this product or install non-authorized components. Doing so will void all warranties, may impair system operation and performance, and can create hazardous conditions for service personnel and occupants. No company employee or contractor is authorized to waive this requirement.



WARNING



Only personnel trained and qualified in the installation, adjustment, servicing, maintenance, or repair of the equipment described in this manual should perform service. The manufacturer is not responsible for any injury or property damage arising from improper service or procedures. In jurisdictions where licensing is required to service this equipment, only licensed personnel should perform the service.

Improper installation, adjustment, servicing, maintenance, or repair—or attempting to perform these tasks without proper training—may result in product damage, property damage, personal injury, or death. Service personnel assume responsibility for any injury or property damage resulting from improper procedures.

TABLE OF CONTENTS

SAFETY CONSIDERATIONS	4-6
NOMENCLATURE	7
GENERAL	8
SHIPPING INFORMATION	8
UNIT INSPECTION CHECKLIST	9
STORAGE	9
REFRIGERATION SYSTEM SERVICING	10-11
A2L SENSING & MITIGATION	12-13
UNIT PHYSICAL DATA	14-18
INSTALLATION	19-25
REFRIGERANT CHARGING	26
CONTROLS	27-34
APPLICATION	35-37
WATER QUALITY REQUIREMENTS	38
ELECTRICAL DATA	39-40
PERFORMANCE DATA	41-51
WIRE DIAGRAM MATRIX	52
WIRING DIAGRAMS	53-59
CIRCUIT SCHEMATICS	60-61
PRE-STARTUP INSPECTION	62
STARTUP & PERFORMANCE CHECKLIST	63-64
OPERATION & MAINTENANCE	65-71
TROUBLESHOOTING	72
SUPPORT/REFERENCE MATERIAL	73

SAFETY CONSIDERATIONS



1. Read this entire Installation, Operation, and Maintenance (IOM) manual before starting installation.
2. These instructions are a general guide. Always follow all national, state, and local codes.
3. Do not alter the product. Do not use unauthorized parts. Doing so will:
 - a. Void the warranty
 - b. Reduce performance
 - c. Cause equipment failure
 - d. Create unsafe conditions

No employee or contractor may override this requirement.
4. Only trained, licensed, and factory-authorized personnel may install or service this unit.
5. Use only factory-authorized kits and accessories. Follow the instructions provided with each kit during installation.

RECOGNIZE THE FOLLOWING SAFETY NOTATIONS





This manual and the equipment use safety symbols and labels.

These labels identify hazards and important information.

- **WARNING** – Risk of serious injury, death, or property damage
- **CAUTION** – Risk of minor or moderate injury
- **ATTENTION** – Important installation or service information

Symbols may indicate:

- Electric shock hazard
- Fire or explosion hazard
- Flammable materials
- Read instructions before operating
- Service information required

	Service indicator; read technical manual
	Operator's manual; operating instructions
	Read the instructions
	Warning; flammable materials
	UN GHS flame symbol

!
DANGER
!

Indicates an imminently hazardous situation which, if not avoided, will result in death or serious injury.

!
WARNING
!

ELECTRIC SHOCK HAZARD

This warning signifies potential electrical shock hazards that could result in personal injury or death.

!
WARNING
!

FIRE OR EXPLOSION HAZARD

This warning indicates potential fire or explosion hazards that could result in personal injury or death.

!
WARNING
!

Indicates a potentially hazardous situation or unsafe practice that could result in severe personal injury or death and/or damage to property.

!
CAUTION
!

Indicates a potentially hazardous situation that may result in minor or moderate personal injury.

!
ATTENTION
!

Provides important installation, operation, or maintenance information that is not hazard-related.

SAFETY CONSIDERATIONS (CONTINUED)

WARNING

ELECTRIC SHOCK HAZARD

Before servicing or performing maintenance on the system, turn OFF the main power to the unit. Failure to do so may result in electrical shock, causing personal injury or death.

WARNING

ELECTRIC SHOCK HAZARD

Disconnect all power supplies before servicing the unit. Lock out and tag out each power source to prevent accidental electrical shock. Note: The unit may be supplied by multiple power sources.

WARNING

 Risk of fire. Flammable Refrigerant Used. Repairs must be performed only by trained service personnel. Do not puncture or damage refrigerant tubing.

Do not install auxiliary devices that could serve as ignition sources in the ductwork, except for those specifically listed for use with this appliance. Refer to the installation instructions for details. Dispose of refrigerant properly in accordance with all federal and local regulations.

WARNING

 Auxiliary devices that could serve as ignition sources must not be installed in the ductwork. Examples of potential ignition sources include electrical switching devices and hot surfaces exceeding 1,292°F [700°C].

WARNING

Failure to follow proper A2L refrigerant handling and mitigation procedures can result in property damage, personal injury, or death.

Exercise extreme caution when installing or servicing systems containing flammable refrigerants. Keep a dry chemical or CO₂ fire extinguisher readily available. Control the work environment to minimize the presence of potentially flammable vapors. Inform all personnel on site of the hazards associated with the work being performed and the required safety precautions.

WARNING

When a Refrigerant Leak Detection System (RDS) is installed, the unit must remain powered at all times, except during service. The installer must verify that the refrigerant sensor is properly installed and fully operational. Failure to do so will void the warranty and may result in fire, property damage, or death.

WARNING

When soldering or brazing, keep a dry powder or CO₂ fire extinguisher readily available. Use heat shields or wet rags to protect valves and sensitive components from heat damage during the process.

WARNING

This appliance is not intended for use by persons (including children) with reduced physical, sensory, or mental capabilities, or by individuals lacking experience or knowledge, unless they are provided with adequate supervision or instruction. Children must be supervised to ensure they do not play with the appliance.

WARNING

Use tools specifically designed for A2L refrigerants. Only non-sparking tools may be used near A2L refrigerants. Open flames and other ignition sources must be avoided, except during brazing, which must be performed only on evacuated and nitrogen-purged refrigerant lines and components exposed to the atmosphere.

WARNING

These instructions are intended to assist qualified, licensed service personnel in the proper installation, adjustment, and operation of this unit. Read all instructions thoroughly before beginning installation or operation.

Failure to follow these instructions may result in improper installation, adjustment, service, or maintenance, which could lead to fire, electrical shock, property damage, personal injury or death.

WARNING

Do not work in confined spaces.

WARNING

REFRIGERANT UNDER PRESSURE

Units are factory charged with refrigerant. Store units in a location that minimizes the potential for physical damage. Do not store units in areas where continuous sources of ignition are present.

Do not use mechanical devices or other means to accelerate the defrosting process or to clean the unit, except as specifically recommended by the manufacturer.

Refrigerants may be odorless. Do not puncture, crush, or expose the unit to flame or excessive heat. Failure to follow these instructions could result in personal injury, death, and/or property damage.

WARNING

Electrical work for the installation of this appliance must comply with the National Electrical Code (NEC) and any applicable local or regional electrical and building codes.

In Canada, all electrical work must comply with CSA C22.1.

The manufacturer assumes no responsibility for equipment installed in violation of applicable codes or regulations.

WARNING

Do not mix R-454B with air for leak testing or any other purpose. Use a mixture of R-454B and nitrogen for leak testing.

R-454B can become combustible when mixed with air under elevated temperature and/or pressure conditions. Failure to follow this warning may result in property damage, personal injury, or death.

SAFETY CONSIDERATIONS (CONTINUED)

! WARNING !
 Prior to beginning work, test the work area for refrigerant using an intrinsically safe A2L refrigerant leak detector.

! CAUTION !
 Use appropriate personal protective equipment when installing or performing maintenance. Wear eye protection and cut-resistant gloves and sleeves to protect against sharp metal edges and fasteners.

! CAUTION !
 After switching off and locking out the electrical disconnect, verify that a safe, de-energized condition exists using a properly rated electrical tester.

! CAUTION !
 Installation and servicing of this equipment can be hazardous due to system pressures and electrical components. Only qualified, licensed installers or service agencies are permitted to install, repair, or service this equipment. Untrained personnel may perform basic maintenance tasks only, such as replacing air filters.

! CAUTION !
 When servicing this equipment, verify that the reversing valve, expansion device, filter drier, and all other system components are specifically rated and approved for use with R-454B, due to the higher operating pressures associated with this refrigerant.

! ATTENTION !
 Do not operate this equipment without an air filter.

! ATTENTION !
 Exercise extreme caution when drilling holes or driving screws into the cabinet to prevent internal damage.

! ATTENTION !
 Equipment should be stored in a clean dry, conditioned area with maximum temperatures up to 120°F [48.9°C] and minimum temperatures to 32.0°F [0.0°C]. Units should be stored upright and in an indoor environment. It is recommended to leave packaging on the unit until the installation is to begin. Store or move units in an upright position at all times.

! ATTENTION !
 This appliance must be installed in a location that is not accessible to the general public.
 This appliance is approved for INDOOR USE ONLY.

! ATTENTION !
 Do not operate these units during construction. Dirt and debris can clog mechanical components and filters, potentially causing system damage. Do not operate these units without a filter.
 The manufacturer does not warrant equipment subjected to misuse.

! ATTENTION !
 Discharge all capacitors before handling any PSC motor or associated wiring.

! ATTENTION !
 Clear surrounding area of all tools, equipment, and debris before operating this unit.

MODEL NOMENCLATURE

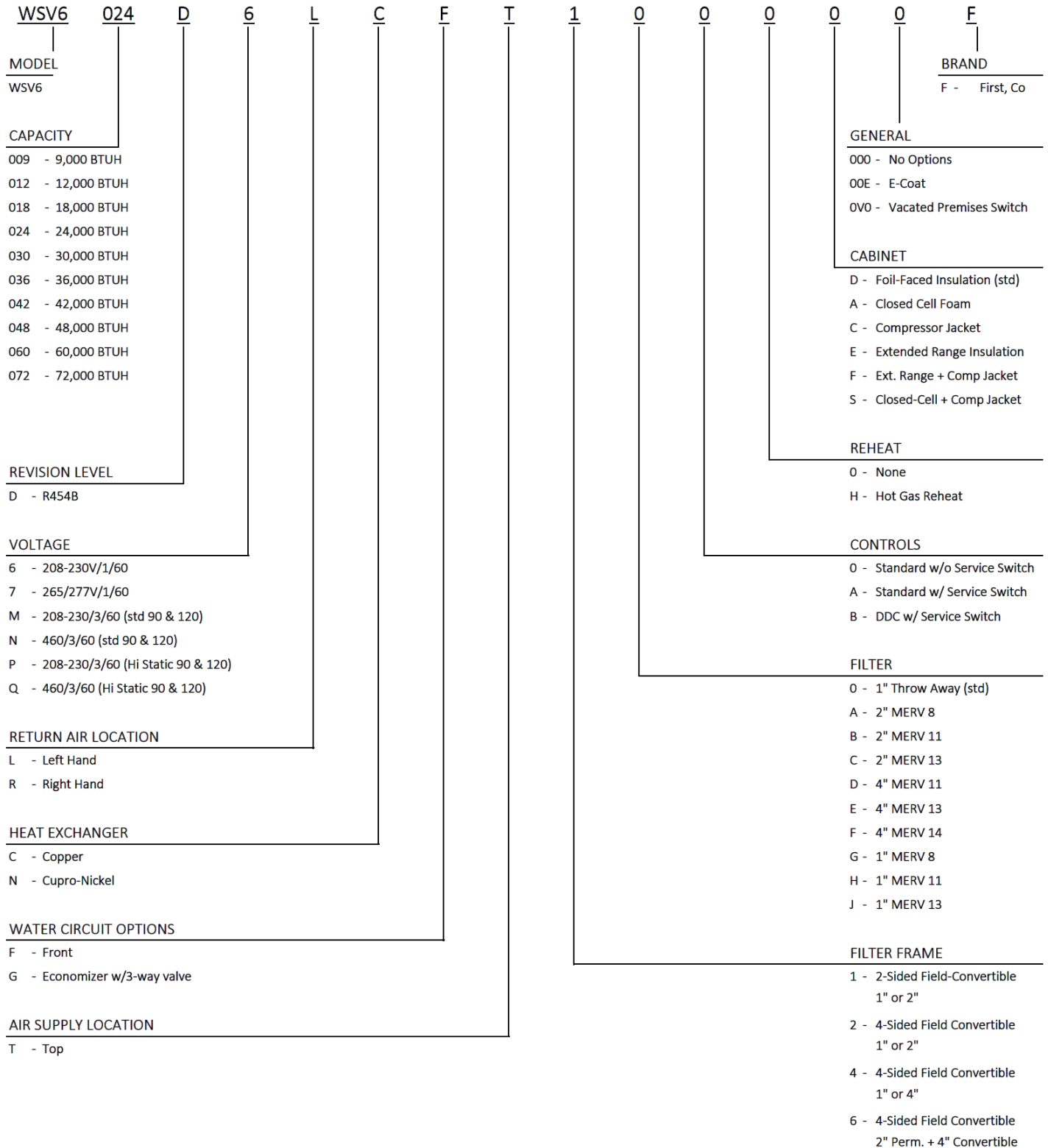

Unit must be selected in Quote-ify to confirm model number is correct

First Co. / AE-Air reserves the right to change, alter, or update data, design features, and specifications without prior notice.

GENERAL

The HydroTech WSV6 Series water-to-air heat pump provides an optimal combination of performance, efficiency, and reliability in a compact design. The WSV6 Series is equipped as standard with ECM blower motors to enhance efficiency and occupant comfort. All models feature double compressor vibration isolation for quiet operation, an easily removable blower housing for simplified servicing, and a single-compressor design to reduce system complexity and improve serviceability.

All WSV6 models are AHRI certified to ISO Standard 13256-1. Units are designed for continuous operation with entering fluid temperatures of 50.0 – 110°F [10.0 – 43.3°C] in cooling mode and 50.0 – 90.0°F [10.0 – 32.2°C] in heating mode. Operation below 50.0°F [10.0°C] or above 90.0°F [32.2°C] entering water temperature requires the extended-range option (insulated tubing), and adequate water flow must be maintained to prevent freezing. An antifreeze solution is required for all applications with entering water temperatures below 50.0°F [10.0°C].



Cooling tower, boiler, and geothermal applications must include sufficient antifreeze protection, where required, to guard against extreme conditions and potential equipment failure. Freeze damage to water coils is not covered under warranty.

These instructions apply only to the installation of WSV6 units. For all other related equipment, refer to the appropriate manufacturer's installation instructions.

	CAUTION	
Do not use this water source heat pump during any phase of construction.		

This unit may be installed at altitudes up to 10,000 ft. (3,048 m).

SHIPPING INFORMATION

	ATTENTION	
All materials in this shipment were inspected at the factory and released to the carrier in good condition.		
Upon receipt, immediately perform a visual inspection of all cartons. Note any signs of rough handling or visible damage on the delivery receipt, and inspect the material in the presence of the carrier's representative. If damage is identified, file a claim with the carrier at once.		

SHIPPING INSTRUCTIONS

Units must remain in the upright position, as shown in **Figure 1 – Standard Packaging**, throughout shipping and handling to ensure proper compressor oil level.

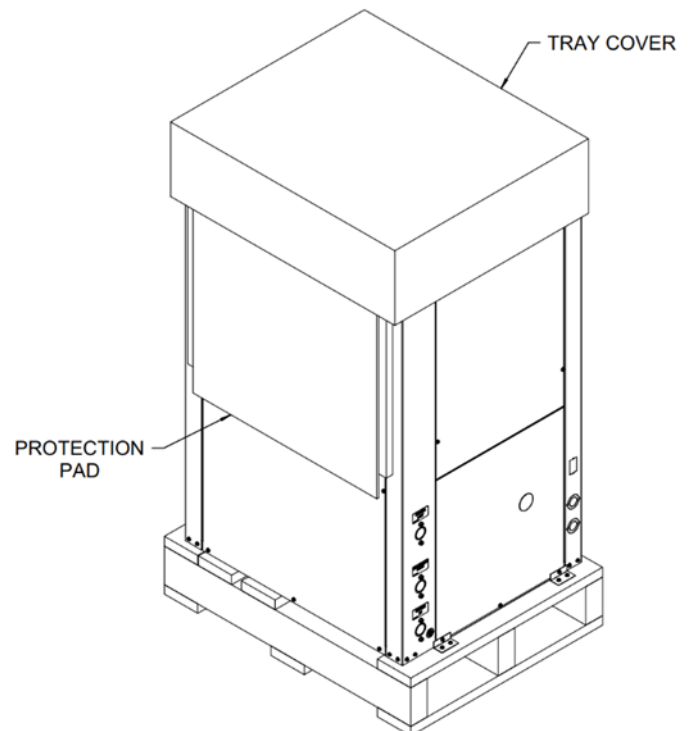

NOTE: SHRINK WRAP AROUND UNIT
Figure 1 – Standard Packaging

PACKAGING LIST

The units will be shipped with the following items:

1. Shipping brackets and screws
2. IOM - Installation & Operations Manual

Check the unit for shipping damage; if found, immediately contact the last carrier.

UNIT INSPECTION CHECKLIST

Complete the inspection procedures below before preparing the unit for installation:

1. Visually inspect unit for any shipping damage. Damage must be reported immediately to the shipping company to make a claim.
2. Ensure that the carrier makes proper notation of any shortages or damage on all copies of the freight bill and completes a common carrier inspection report.
3. Verify that the name plates on each unit match the sales order or bill of lading (including, unit configuration, size, and voltage).
4. Immediately before installation, remove the unit's front panel and verify that all electrical connections are secure and free of loose wires.
5. Ensure the refrigerant piping is free of kinks and that it does not come into contact with sheet metal or electrical wiring.
6. Verify that the blower spins freely within the housing and that no obstructions exist between the wheel and housing. Check that the blower wheel is securely fastened, as it may loosen during shipping.
7. Ensure the evaporator distributor tubes are not touching each other and are positioned above the drain pan.
8. Check the air-coil fins for any damage during shipping.
9. Ensure that the shipping screws are removed from the unit. Refer to **Figure 2 – Standard Packaging with Brackets** for more information.

!	ATTENTION	!
Verify the unit nameplate voltage against the project plans before installing the equipment. Ensure all electrical ground connections are installed in accordance with applicable local codes.		

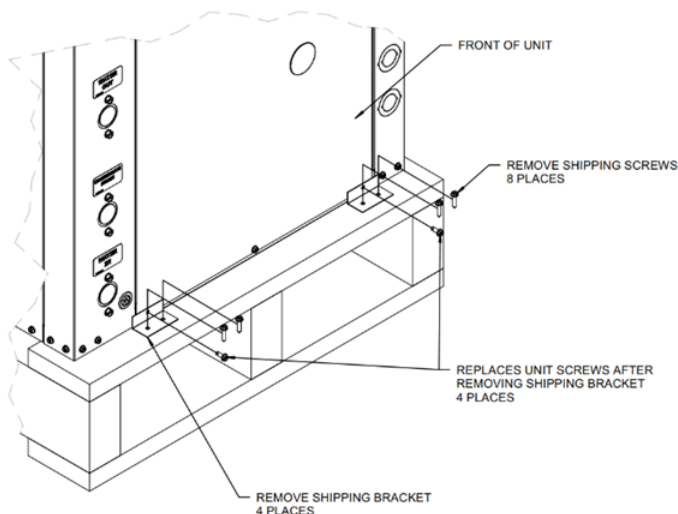

Figure 2 – Standard Packaging with Brackets

STORAGE

Equipment shall be stored in a clean, dry, conditioned indoor area. Storage temperatures shall not exceed 120°F [48.9°C] and shall not fall below 32.0°F [0.0°C]. Units shall be stored upright and protected from environmental exposure, as seen in **Figure 2 - Standard Packaging with Brackets**.

Packaging shall remain in place until installation begins to prevent damage and contamination.

!	WARNING	!
Store cabinets in the upright position as shipped, keeping them crated and on their pallets for protection. Failure to follow these instructions may result in improper installation, service, or maintenance, as well as property damage, personal injury, or death.		

!	CAUTION	!
Do not stack units. Stacking units may result in system and/or property damage.		

REFRIGERATION SYSTEM SERVICING

Tools required for installing and servicing A2L units.

Manifolds sets:

- Up to 600 PSIG High Side (41 bar)
- Up to 250 PSIG Low Side (17 bar)

WARNING

This unit is factory-charged with 3.5 lbs (1.6 kg) of refrigerant for safe storage. Additional A2L refrigerant will be required during installation to achieve proper system operation. Refer to the charging instructions in the installation manual for correct charge adjustments.

WARNING

When soldering or brazing, always keep a fire extinguisher readily available. When working near valves or other sensitive components, use heat shields or wet rags to protect these parts from heat exposure. Failure to protect components during soldering or brazing can result in damage to valves and other critical parts, leading to equipment malfunction or unsafe operating conditions.

WARNING

Do not exceed the maximum operating pressure listed on the unit rating plate.

ATTENTION

Do not open the service valves until the evaporator section and all connecting tubing have been installed, leak-tested, and properly evacuated. Service valves are to be opened only when the system is fully prepared for operation. Premature opening may result in refrigerant loss, contamination, or system damage.

WARNING

Always recover all refrigerant before performing any repairs on a sealed air-conditioning system and before final disposal of the unit. Ensure that all service ports are used and that every refrigerant flow-control device—including expansion valves and solenoid valves—is fully open. Failure to follow these procedures may result in serious injury or death.

WARNING

FIRE OR EXPLOSION HAZARD

Failure to follow these instructions could result in personal injury, death, or property damage.

Do not attempt any sealed system repair without first recovering the entire refrigerant charge. A2L refrigerant mixed with oil can ignite when exposed to a brazing torch flame. Always recover the full refrigerant charge from both the high and low sides of the system, and purge the sealed system with nitrogen before brazing any component or tubing.

All piping must be protected from physical damage during operation and service and comply with all applicable national and local codes and standards, such as ASHRAE 15, ASHRAE 15.2, IAPMO Uniform Mechanical Code, ICC International Mechanical Code, or CSA B52. Field joints must remain accessible for inspection before being covered or enclosed.

When routing lines from the evaporator coil to the condensing unit, keep them as short as possible, with a maximum allowable length of 50.0 ft (15.0 m). Knockouts are provided at both upper corners and on each side of the unit cabinet for line entry; only remove the openings needed and seal any unused openings to prevent air leakage, which can reduce airflow over the condenser coil. Service valves are designed for sweat connections—avoid overheating the valve by using a wet cloth for protection during brazing. Ensure that line routing does not obstruct removal of the motor or fan through the access panel or block access panel removal.

The suction line must be insulated to prevent condensation, using insulation with a minimum wall thickness of 0.4" (9.5 mm) and an adequate vapor barrier, extending a few inches (50.0 – 100 mm) inside the unit cabinet to contain any condensation safely.

PURGING & LEAK TESTING

WARNING

FIRE OR EXPLOSION HAZARD

Do not use open flames or any potential ignition sources when performing leak checks on refrigerant tubing or components. Failure to comply with this instruction may result in personal injury, death, or property damage.

Connect the suction and liquid hoses from the gauge manifold to the service ports on the service valves. A hole covered by a plastic snap plug is provided for gauge hose entry, allowing the unit access panel to be reinstalled without disturbing the hoses. Once the gauge hoses are removed, ensure the plastic plug is replaced to cover the service hole. Connect a cylinder of dry nitrogen to the gauge manifold and open both the liquid and suction manifold valves. After the system reaches balanced pressure, perform a leak test on all sweat fittings. If any leaks are detected, repair them and repeat the procedure.

WARNING

FIRE OR EXPLOSION HAZARD

Never use an open flame to test for refrigerant leaks. Always use a commercially available soap solution specifically designed for leak detection to check all connections. Failure to follow this instruction may result in fire or explosion, causing property damage, serious injury, or loss of life.

Strict adherence to these safety warnings is required to prevent severe injury, death, or property damage.

WARNING

Always recover all refrigerant before performing any repairs on a sealed air-conditioning system and before final disposal of the unit. Ensure that all service ports are used and that every refrigerant flow-control device—including expansion valves and solenoid valves—is fully open. Failure to follow these procedures may result in serious injury or death.

REFRIGERATION SYSTEM SERVICING (CONTINUED)

EVACUATION & SYSTEM PREPARATION PROCEDURE

1. **Determine Evacuation Requirement**
Evacuation of the condensing unit is not necessary unless the unit has lost its refrigerant charge. If the charge is intact, leave the service valves closed.
2. **Recover Refrigerant**
Recover the refrigerant from the evaporator coil and connecting tubing only.
3. **Connect Vacuum Pump**
Attach the vacuum pump to the charging port on the gauge manifold.
4. **Start Evacuation**
Start the vacuum pump and open the suction hand valve on the gauge manifold.
5. **Achieve Target Vacuum**
Allow the pump to operate until a vacuum of 300 microns is reached.
6. **Check Pressure Stability**
Shut off the vacuum pump and monitor the system pressure.
 - a. If the pressure rises above 500 microns, restart the pump, and continue evacuation until the system can maintain 500 microns or lower.
7. **Secure System**
Close the hand valves on the gauge manifold and disconnect the vacuum pump.
8. **Open Service Valves**
Open the service valves on the condensing unit.
9. **Verify Readiness**
The refrigeration system is now prepared for normal operation.

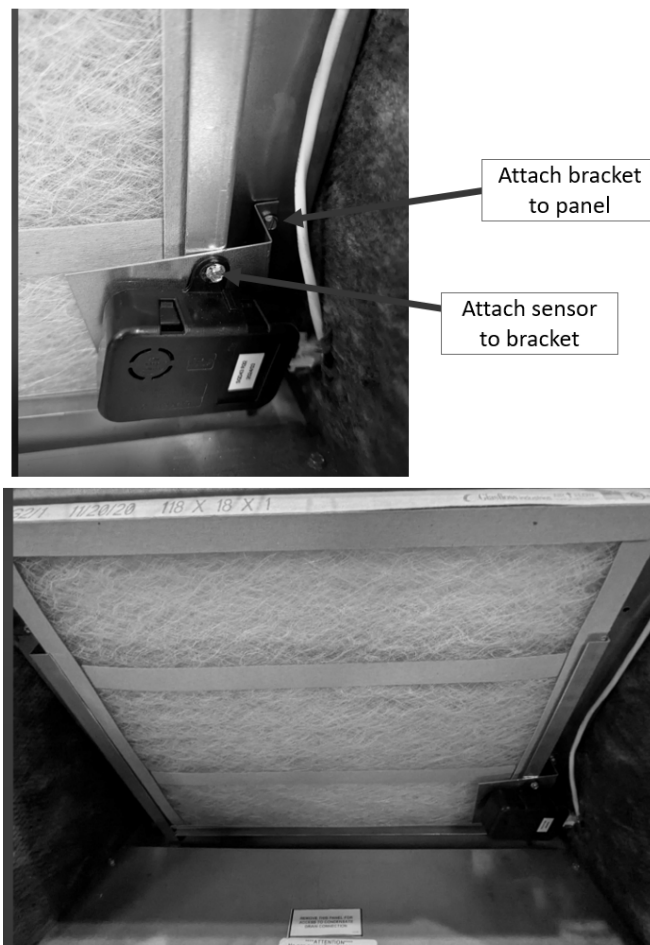

Figure 3 – A2L Sensor Placement

A2L SENSOR REPLACEMENT

1. Remove the front bottom panel to access the coil.
2. Disconnect the A2L harness from the currently installed sensor.
3. Remove the existing A2L sensor from its bracket by loosening the two mounting screws. Reuse these screws to install the new sensor (as shown in **Figure 3 – A2L Sensor Placement**).
4. Mount the new sensor onto the bracket using the two existing screws. **CAUTION:** Do not screw into the coil or tubing (as shown in **Figure 3 – A2L Sensor Placement**).
5. Reconnect the A2L harness to the newly installed sensor.

A2L SENSING AND MITIGATION

Units charged with more than 4.0 lbs [1.8 kg] of R-454B (A2L) refrigerant are factory equipped with a refrigerant leak detector (A2L sensor). Upon detection of a refrigerant leak, the control system shall disable compressor operation and energize the evaporator fan to disperse leaked refrigerant.

The unit shall remain in this mitigation mode until the sensor no longer detects refrigerant and for a minimum duration of 5 minutes. After the mitigation period has elapsed, the unit shall automatically return to normal operation in accordance with the active thermostat inputs.

Refer to **Table 3: Status Light Table for Refrigerant Detection System (RDS)** for LED status definitions.

WARNING	
FIRE OR EXPLOSION HAZARD	
<p>Risk of fire. Flammable Refrigerant Used. Repairs must be performed only by trained service personnel. Do not puncture or damage refrigerant tubing.</p> <p>Do not install auxiliary devices that could serve as ignition sources in the ductwork, except for those specifically listed for use with this appliance. Refer to the installation instructions for details. Dispose of refrigerant properly in accordance with all federal and local regulations.</p>	

WARNING	
<p>Dispose of refrigerant in accordance with all applicable federal, state, and local regulations.</p> <p>Failure to follow proper A2L refrigerant mitigation system installation and handling procedures may result in property damage, personal injury, or death. If any fault indicators are present, troubleshoot and correct the condition immediately to prevent system malfunction.</p>	

Table 1: A2L Sensing & Mitigation					
System Charge		Min. Room Area		Min. Mitigation Airflow	
(lb)	(kg)	(sq ft)	(sq m)	(CFM)	(m ³ /hr)
4.0	1.8	60.0	5.6	108	184
5.0	2.3	75.0	7.0	135	230
6.0	2.7	90.0	8.4	162	276
7.0	3.2	105	9.8	189	322
8.0	3.6	120	11.1	216	368
9.0	4.1	135	12.5	243	414
10.0	4.5	150	13.9	271	460
11.0	5.0	165	15.3	298	506
12.0	5.4	180	16.7	325	552
13.0	5.9	195	18.1	352	598
14.0	6.4	210	19.5	379	644
15.0	6.8	225	20.9	406	689
16.0	7.3	240	22.3	433	735
17.0	7.7	255	23.7	460	781
18.0	8.2	270	25.1	487	827
19.0	8.6	285	26.5	514	873
20.0	9.1	300	27.9	541	919
21.0	9.5	315	29.3	568	965
22.0	10.0	330	30.6	595	1,011
23.0	10.4	345	32.0	622	1,057
24.0	10.9	360	33.4	649	1,103
25.0	11.3	375	34.8	676	1,149

Table 2: Altitude Correction Factor													
Altitude (Ft) [m]	2,625 [800]	3,281 [1,000]	4,000 [1,200]	4,693 [1,400]	5,349 [1,600]	5,906 [1,800]	6,562 [2,000]	7,218 [2,200]	7,874 [2,400]	8,530 [2,600]	9,186 [2,800]	9,843 [3,000]	10,499 [3,200]
Adj Factor (AF)	1.02	1.05	1.07	1.10	1.12	1.15	1.18	1.21	1.25	1.28	1.32	1.36	1.40

First Co. / AE-Air reserves the right to change, alter, or update data, design features, and specifications without prior notice.

A2L SENSING AND MITIGATION (CONTINUED)

Table 3: Status Light Table for Refrigerant Detection System (RDS)		
Status Light	State / Condition	System Response
Green Blinking	Normal Operation	<ul style="list-style-type: none"> The system is actively monitoring refrigerant levels. No refrigerant detected above the activation threshold. Outdoor unit compressor and indoor blower operate normally.
Red Continuous	Refrigerant Leak Detected	<ul style="list-style-type: none"> Refrigerant concentration exceeds the activation threshold. The outdoor unit compressor (Y) is turned off to prevent further circulation of refrigerant. The indoor blower is turned on to recirculate air and mitigate the refrigerant concentration.
Red Blinking	Fault Detected	<ul style="list-style-type: none"> A fault in the refrigerant detection system (e.g., calibration issue, end-of-life) has been detected. The outdoor unit compressor (Y) and indoor blower mitigation mode are deactivated for safety. System requires inspection or replacement.
No Light	System Off or Malfunction	<ul style="list-style-type: none"> The system is not operational. Check the power supply and all system connections.
Amber Blinking	System Initializing	<ul style="list-style-type: none"> The system is warming up after power-up. The outdoor unit compressor (Y) and indoor blower mitigation mode remain inactive during this phase. Transitions to green blinking when monitoring begins.

UNIT PHYSICAL DATA

Table 4: Physical Data										
	WSV6009	WSV6012	WSV6018	WSV6024	WSV6030	WSV6036	WSV6042	WSV6048	WSV6060	WSV6072
Compressor Type (Qty)	Rotary (1)		Scroll (1)							
Factory Charge (R-454B) (lbs.) [kg]	1.5 [0.68]	1.6 [0.73]	1.9 [0.88]	2.2 [1.0]	2.8 [1.3]	3.1 [1.4]	4.1 [1.9]	4.3 [2.0]	6.0 [2.8]	5.0 [2.3]
A2L Sensor & Mitigation (YES/NO)	NO						YES			
Min. Room Area (Ft ²) [m ²]	N/A						62.0 [5.8]	68.0 [6.3]	75.0 [6.0]	114 [10.6]
Min. Air Flow (CFM) [m ³ /hr]	N/A						111 [189]	123 [210]	135 [230]	205 [348]
Fan Motor (Qty)	1									
Fan Motor Type	ECM									
Fan Motor (HP) [kW]	1/4 [0.2]	1/4 [0.2]	1/3 [0.2]	1/2 [0.4]	1/2 [0.4]	1/2 [0.4]	3/4 [0.6]	1 [0.8]	1 [0.8]	1 [0.8]
Blower Wheel Size (D x W) (in.) [cm]	6.8 x 7.0 [17.2 x 17.8]		9.0 x 7.0 [22.9 x 17.8]		10.0 x 8.0 [25.4 x 20.3]		10.0 x 8.0 [25.4 x 20.3]		11.0 x 10.0 [28.0 x 25.4]	
Water Connection (in.) [cm]	3/4 [1.9]						1 [2.5]			
COAX Volume (US Gallons) [L]	0.12 [0.45]	0.14 [0.53]	0.14 [0.53]	0.36 [1.36]	0.43 [1.63]	0.53 [2.0]	0.62 [2.35]	0.91 [3.44]	0.91 [3.44]	1.08 [4.09]
Condensate Connection FPT (in) [cm]	3/4 [1.9]									
Air Coil Dimension (H x W) in. [cm]	18.0 x 16.4 [17.2 x 41.6]				20.0 x 16.3 [50.8 x 41.3]	24.0 x 20.9 [61.0 x 53.0]	28.0 x 20.9 [71.1 x 53.0]		36.0 x 20.9 [91.4 x 53.0]	
Filter Size (H x W) in. [cm]	18.0 x 20.0 [45.7 x 50.8]				20.0 x 20.0 [50.8 x 50.8]	24.0 x 24.0 [61.0 x 61.0]	24.0 x 30.0 [61.0 x 76.2]		18.0 x 24.0 [45.7 x 61.0]	20.0 x 24.0 [50.8 x 61.0]
Filter (Qty)	1								2	
Operating Weight (lb.) [kg]	155 [70.3]	160 [72.6]	190 [86.2]	205 [93.0]	215 [97.5]	250 [113]	290 [132]	315 [143]	360 [163]	365 [166]
Shipping Weight (lb.) [kg]	164 [74.4]	166 [75.3]	195 [88.5]	208 [94.4]	221 [100]	254 [115]	295 [134]	320 [145]	365 [166]	370 [168]

First Co. / AE-Air reserves the right to change, alter, or update data, design features, and specifications without prior notice.

UNIT PHYSICAL DATA (CONTINUED)

Table 5: Dimensional Data (in) [cm]											
Model	Cabinet					Supply Air Connections					
	A	B	C	W	X	D	E	F	G	H	J
WSV6009	21.5 [54.6]	21.5 [54.6]	36.3 [92.1]	18.3 [46.4]	2.0 [5.1]	9.5 [24.1]	7.8 [19.7]	4.3 [10.8]	4.5 [11.4]	12.8 [32.4]	4.3 [10.8]
WSV6012	21.5 [54.6]	21.5 [54.6]	36.3 [92.1]	18.3 [46.4]	2.0 [5.1]	9.5 [24.1]	7.8 [19.7]	4.3 [10.8]	4.5 [11.4]	12.8 [32.4]	4.3 [10.8]
WSV6018	21.5 [54.6]	21.5 [54.6]	36.3 [92.1]	18.3 [46.4]	2.0 [5.1]	5.5 [14.0]	13.8 [34.9]	2.3 [5.7]	3.5 [8.9]	16.3 [41.3]	1.8 [4.5]
WSV6024	21.5 [54.6]	21.5 [54.6]	36.3 [92.1]	18.3 [46.4]	2.0 [5.1]	5.5 [14.0]	13.8 [34.9]	2.3 [5.7]	3.5 [8.9]	16.3 [41.3]	1.8 [4.5]
WSV6030	21.5 [54.6]	21.5 [54.6]	39.3 [99.7]	19.3 [48.9]	2.0 [5.1]	5.5 [14.0]	13.8 [34.9]	2.3 [5.7]	3.5 [8.9]	16.3 [41.3]	1.8 [4.5]
WSV6036	21.5 [54.6]	26.0 [66.0]	43.3 [109.9]	19.3 [48.9]	2.0 [5.1]	5.0 [12.7]	15.8 [40.0]	0.8 [1.9]	5.0 [12.7]	16.3 [41.3]	4.8 [12.1]
WSV6042	26.0 [66.0]	26.0 [66.0]	43.3 [109.9]	13.3 [33.7]	2.0 [5.1]	7.3 [18.4]	17.8 [45.1]	1.0 [2.5]	5.0 [12.7]	17.8 [45.1]	3.3 [8.3]
WSV6048	26.0 [66.0]	26.0 [66.0]	43.3 [109.9]	13.3 [33.7]	2.0 [5.1]	7.3 [18.4]	17.8 [45.1]	1.0 [2.5]	5.0 [12.7]	17.8 [45.1]	3.3 [8.3]
WSV6060	26.0 [66.0]	26.0 [66.0]	51.3 [130.2]	13.3 [33.7]	2.0 [5.1]	5.3 [13.4]	19.0 [45.1]	1.8 [4.5]	4.8 [12.1]	19.0 [48.3]	2.3 [5.7]
WSV6072	26.0 [66.0]	26.0 [66.0]	51.3 [130.2]	13.3 [33.7]	2.0 [5.1]	5.3 [13.4]	19.0 [45.1]	1.8 [4.5]	4.8 [12.1]	19.0 [48.3]	2.3 [5.7]

Table 6: Dimensional Data Cont. (in) [cm]										
Model	Water Connections			Return Air Connections			Electrical Connections			
	K	M	N	P	Q	R	S	T	U	V
WSV6009	2.8 [7.0]	7.3 [18.4]	13.3 [33.8]	17.5 [44.5]	16.0 [40.6]	18.0 [45.7]	4.3 [10.8]	6.8 [17.2]	10.5 [26.7]	15.0 [38.1]
WSV6012	2.8 [7.0]	7.3 [18.4]	13.3 [33.8]	17.5 [44.5]	16.0 [40.6]	18.0 [45.7]	4.3 [10.8]	6.8 [17.2]	10.5 [26.7]	15.0 [38.1]
WSV6018	2.8 [7.0]	7.3 [18.4]	13.3 [33.8]	17.5 [44.5]	16.0 [40.6]	18.0 [45.7]	4.3 [10.8]	6.8 [17.2]	10.5 [26.7]	15.0 [38.1]
WSV6024	2.8 [7.0]	7.3 [18.4]	12.8 [32.4]	17.5 [44.5]	16.0 [40.6]	18.0 [45.7]	4.3 [10.8]	6.8 [17.2]	10.5 [26.7]	15.0 [38.1]
WSV6030	2.8 [7.0]	7.3 [18.4]	12.8 [32.4]	17.5 [44.5]	18.0 [45.7]	20.0 [50.8]	4.3 [10.8]	6.8 [17.2]	10.5 [26.7]	15.0 [38.1]
WSV6036	2.8 [7.0]	7.3 [18.4]	12.8 [32.4]	17.5 [44.5]	22.0 [55.9]	24.0 [61.0]	4.3 [10.8]	6.8 [17.2]	10.5 [26.7]	15.0 [38.1]
WSV6042	2.8 [7.0]	6.3 [15.9]	L: 10.8 [27.31] R: 16.8 [42.5]	22.0 [55.9]	28.0 [71.1]	30.0 [76.2]	2.5 [6.4]	5.0 [12.7]	7.8 [19.7]	10.5 [26.7]
WSV6048	2.8 [7.0]	6.3 [15.9]	10.8 [27.3]	22.0 [55.9]	28.0 [71.1]	30.0 [76.2]	2.5 [6.4]	5.0 [12.7]	7.8 [19.7]	10.5 [26.7]
WSV6060	2.8 [7.0]	6.3 [15.9]	10.8 [27.3]	22.0 [55.9]	28.0 [71.1]	38.0 [96.5]	2.5 [6.4]	5.0 [12.7]	7.8 [19.7]	10.5 [26.7]
WSV6072	2.8 [7.0]	6.3 [15.9]	10.8 [27.3]	22.0 [55.9]	28.0 [71.1]	38.0 [96.5]	2.5 [6.4]	5.0 [12.7]	7.8 [19.7]	10.5 [26.7]

First Co. / AE-Air reserves the right to change, alter, or update data, design features, and specifications without prior notice.

UNIT PHYSICAL DATA (CONTINUED)

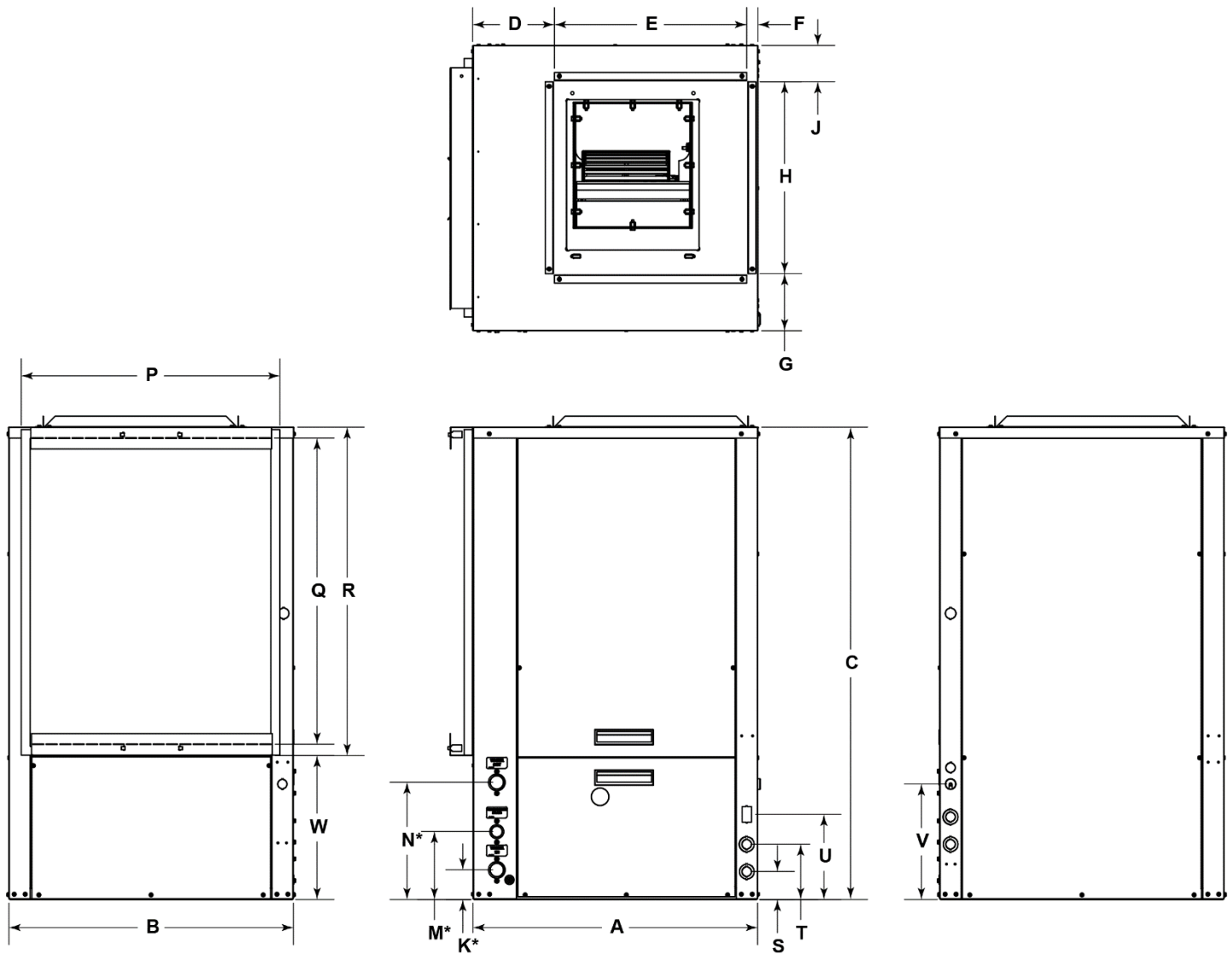

Figure 4 - Unit Dimensions

- * K = Water In
- * M = Condensate Drain
- * N = Water Out

UNIT PHYSICAL DATA (CONTINUED)

Table 7: Economizer Dimensional Data (in) [cm]																
Model	A	A'		B		C	D	E	F		G	H	I	J	K	L
		1"	2"	L	R				L	R						
WSV6048	31.6 [80.2]	0.9 [2.3]	1.9 [4.9]	30.4 [77.2]	29.8 [75.7]	43.2 [110]	2.7 [6.9]	6.2 [15.8]	10.7 [27.2]	16.7 [42.5]	5.3 [13.3]	18.9 [48.0]	1.9 [4.9]	2.4 [6.1]	18.9 [48.0]	4.8 [12.1]
WSV6060	31.6 [80.2]	0.9 [2.3]	1.9 [4.9]	30.4 [77.2]	29.8 [75.7]	51.2 [130]	2.7 [6.9]	6.2 [15.8]	10.7 [27.2]	16.7 [42.5]	5.3 [13.3]	18.9 [48.0]	1.9 [4.9]	2.4 [6.1]	18.9 [48.0]	4.8 [12.1]
WSV6072	31.6 [80.2]	0.9 [2.3]	1.9 [4.9]	30.4 [77.2]	29.8 [75.7]	51.2 [130]	2.7 [6.9]	6.2 [15.8]	10.7 [27.2]	16.7 [42.5]	5.3 [13.3]	18.9 [48.0]	1.9 [4.9]	2.4 [6.1]	18.9 [48.0]	4.8 [12.1]

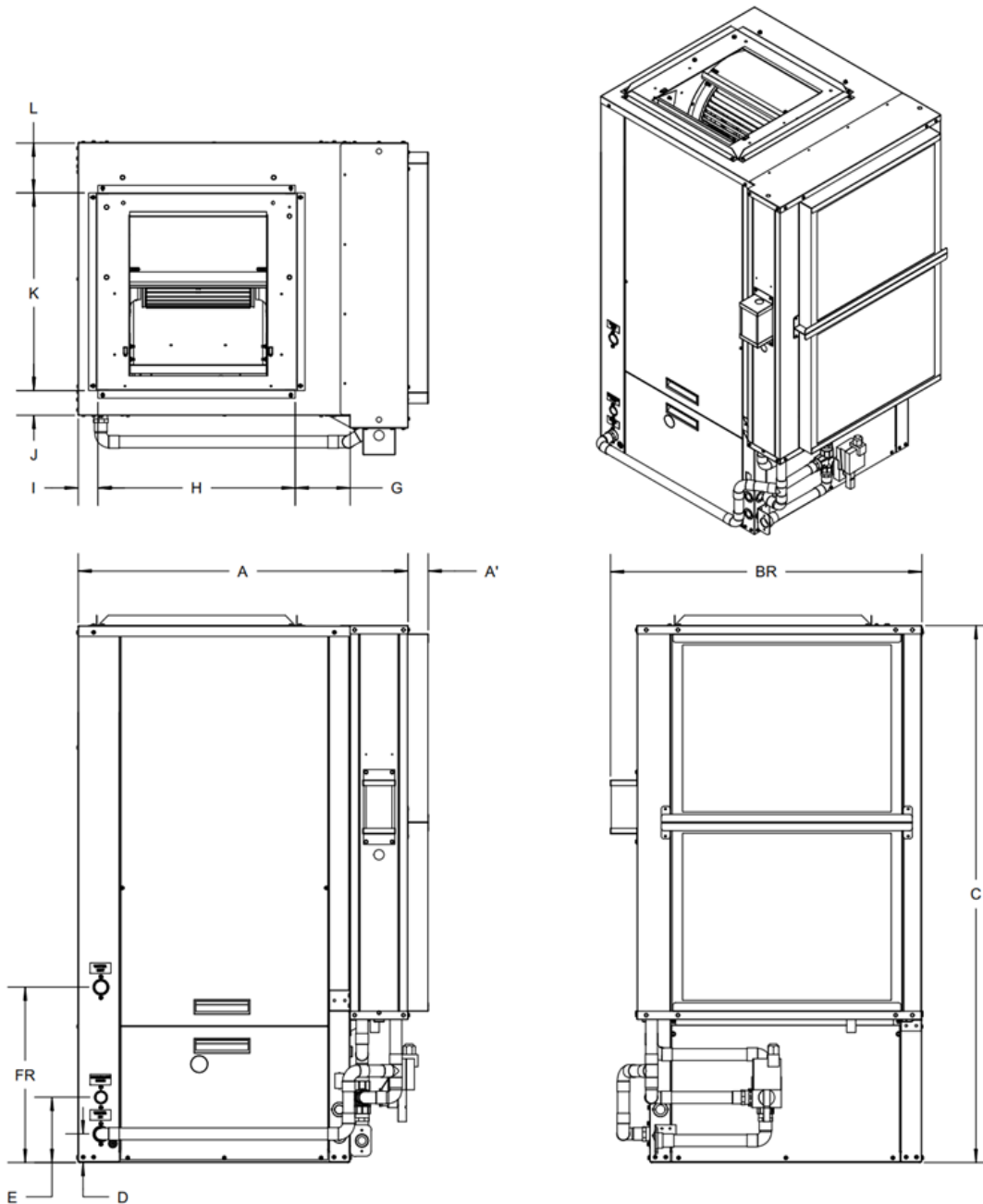

Figure 5 - Unit Dimensions Economizer RH

First Co. / AE-Air reserves the right to change, alter, or update data, design features, and specifications without prior notice.

UNIT PHYSICAL DATA - ECONOMIZER

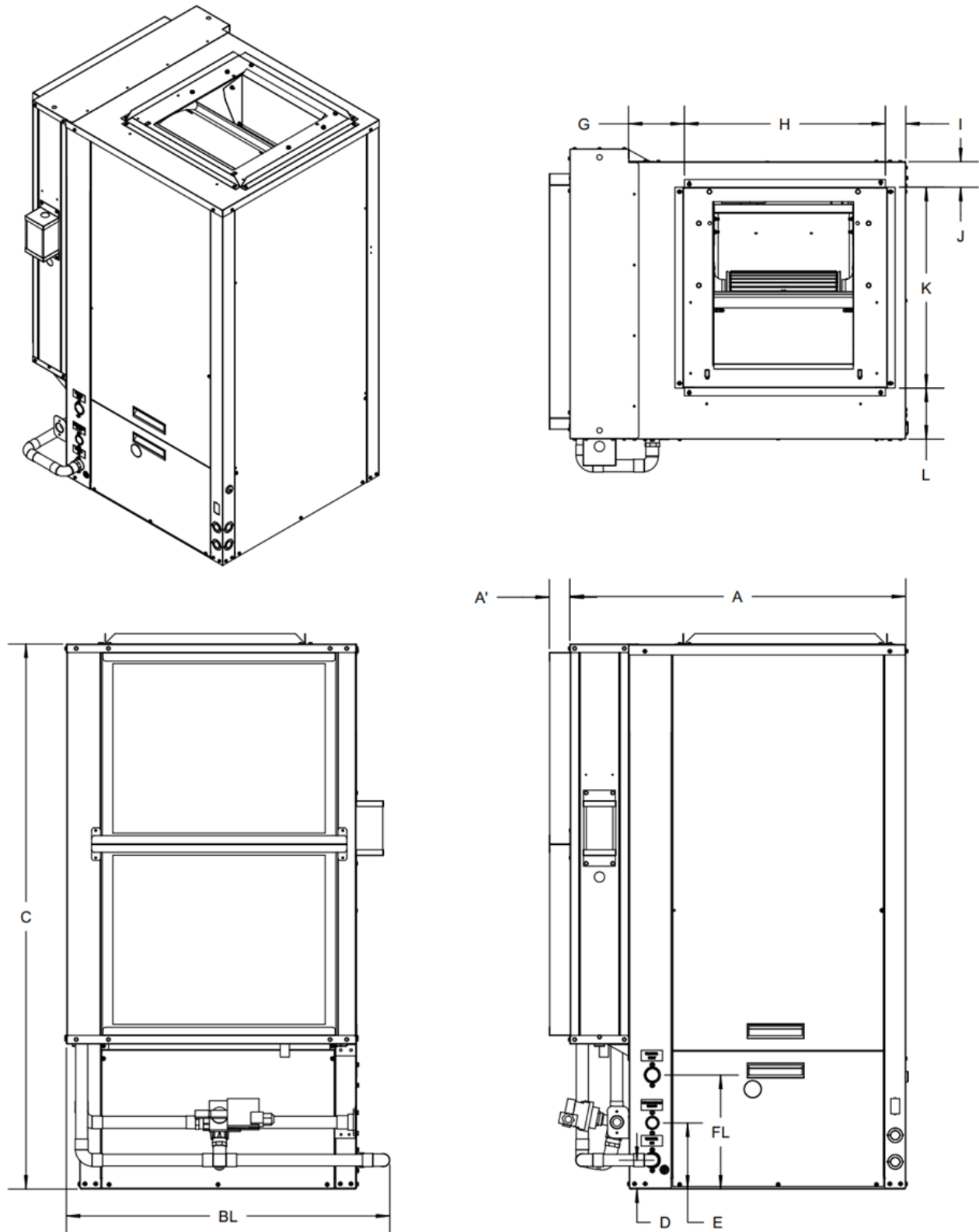

Figure 6 - Unit Dimensions Economizer LH

First Co. / AE-Air reserves the right to change, alter, or update data, design features, and specifications without prior notice.

INSTALLATION

REQUIREMENTS

These instructions are provided for the installation of the WSV6 water source heat pump specifically. Follow manufacturer's installation instructions, as well as local and municipal building codes. For any other related equipment, refer to the appropriate manufacturer's instructions.

INSTALLATION PRECAUTIONS

WARNING
Use multiple people when moving and installing these units. Failure to do so could result in injury or death.

WARNING
Wear appropriate personal protective equipment (PPE) during installation and service. Sharp metal edges and corners may cause injury. Protective gloves shall be worn when handling. Exercise caution when installing or servicing the unit.

Observe the following precautions for typical installation:

- Always use proper tools and equipment.
- Do not perform any wiring or service work until the unit is completely disconnected from the power source and properly locked out. Verify that a permanent, uninterrupted ground connection is in place before energizing the unit.
- Review the unit nameplate and wiring diagram to confirm correct voltage and control configurations, as these may vary by unit.

CAUTION
When the unit is operating, internal components rotate at high speeds. Avoid contact to prevent personal injury.

ATTENTION
The WSV6 water source heat pump is designed for indoor installation only. Installation of this equipment, wiring, ducts, and any related components must conform to current agency codes, state laws, and local codes. Such regulations take precedence over general instructions contained in this manual.

ATTENTION
Insulation provides a barrier between the unit's internal environment and external conditions. Damaged insulation can lead to condensation, corrosion, component failure, and potential property damage. Repair or replace any damaged insulation before operating the unit. Note that insulation loses effectiveness when wet, torn, separated, or otherwise compromised.

UNIT CLEARANCE REQUIREMENTS

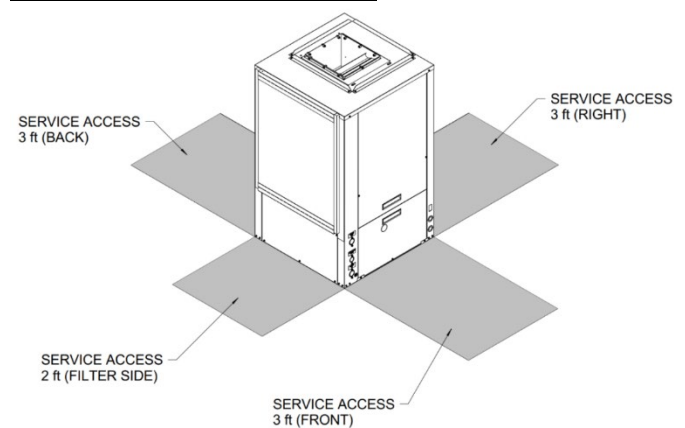

Figure 7 - Unit Clearance Requirements

UNIT LOCATION

Install the unit in a location that meets the **minimum clearance and access requirements** shown in Figures 4–6. Refer to **Figure 7 – Unit Clearance Requirements**, for detailed service access dimensions. Allow additional clearance as required for water piping, electrical connections, duct connections, and adequate return airflow.

UNITS ARE ONLY INTENDED FOR INDOOR INSTALLATION!

INSTALLATION (CONTINUED)

UNIT LOCATION (CONTINUED)

Do not locate the unit in areas subject to freezing temperatures or where high humidity conditions may cause cabinet condensation. WSV6 units are available in both right-hand and left-hand configurations. Units must be installed level and pitched toward the condensate drain, as shown in **Figure 8 – Mounting Installation**. Use 3/8–1/2” vibration isolation pads to minimize the transmission of vibration.

!	ATTENTION	!
<p>Ensure the unit is securely mounted and that the supporting structure is capable of safely supporting the full operating weight of the equipment. Properly select, locate, and size all anchors to provide a safe, stable, and durable installation.</p>		

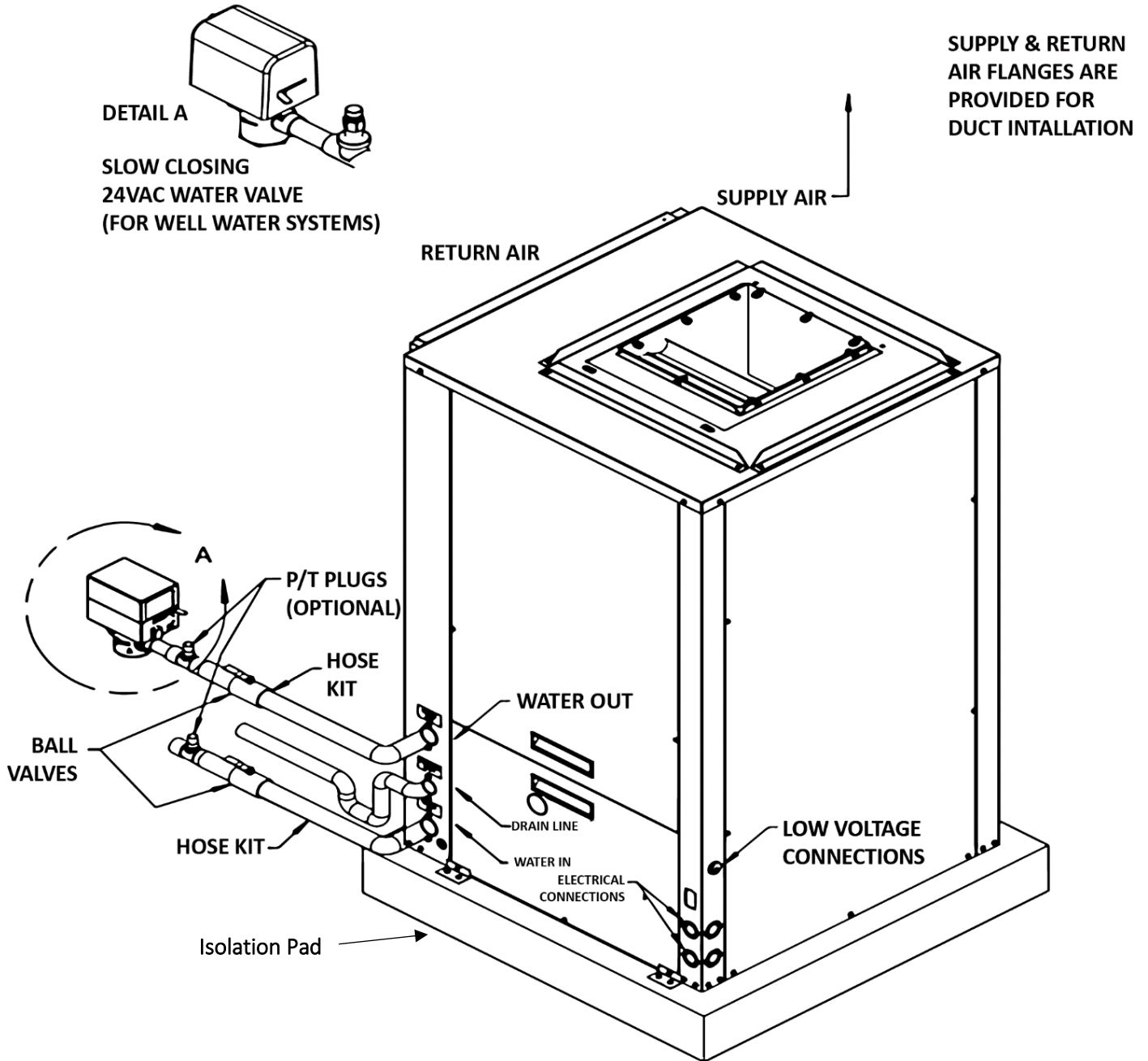

Figure 8 - Mounting Installation

First Co. / AE-Air reserves the right to change, alter, or update data, design features, and specifications without prior notice.

INSTALLATION (CONTINUED)

FILTER BRACKETS

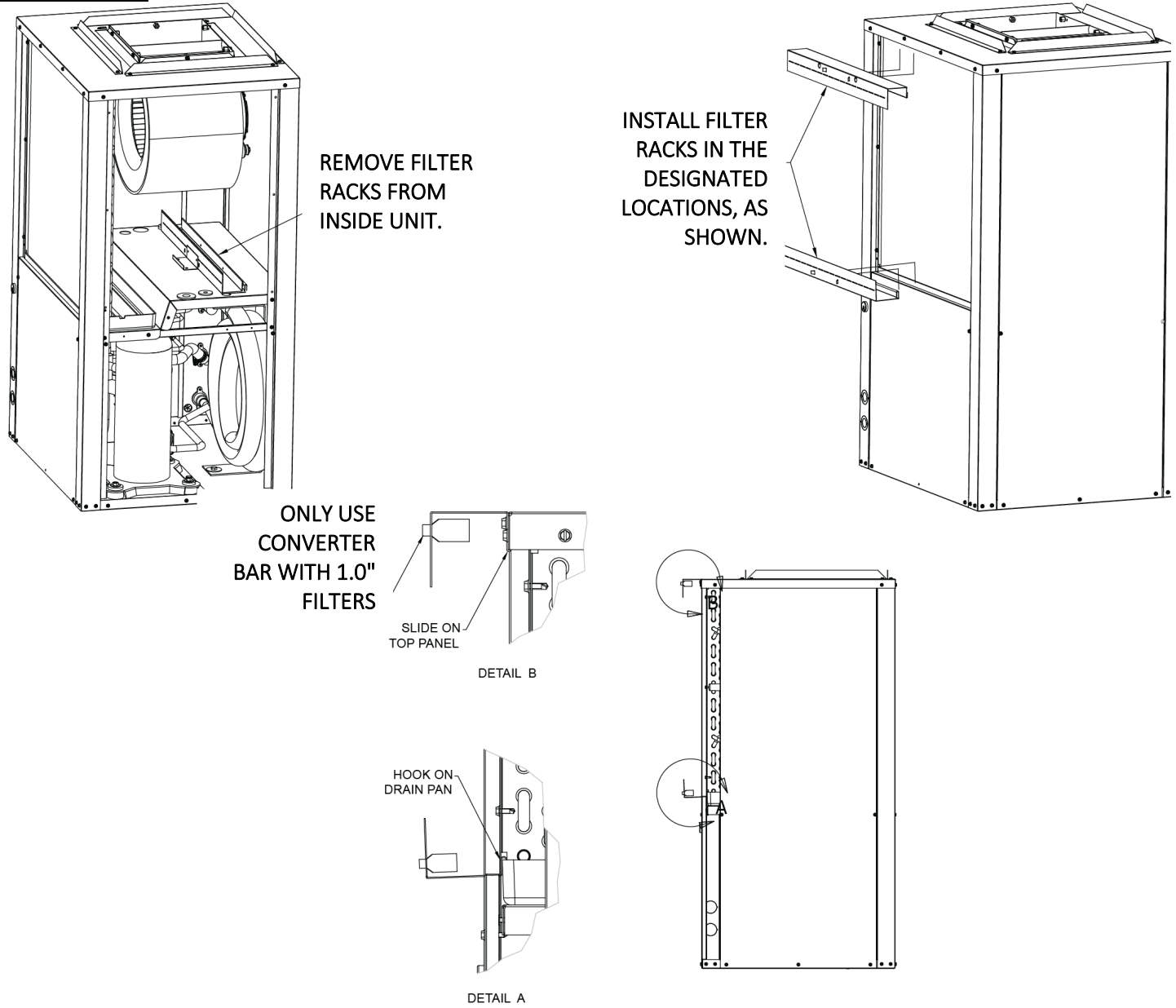

Figure 9 – Filter Bracket Detail

ATTENTION

Filter brackets are shipped inside the unit and are located in the blower compartment. The brackets must be removed and mounted to the exterior of the cabinet prior to unit mounting or installation. Refer to Figure 9 – Filter Bracket Detail.

WARNING



Remove all shipping blocks from beneath the blower housing prior to installing the unit.

CAUTION

Carefully follow all instructions and recommendations provided with the filter rack kit.

INSTALLATION (CONTINUED)

PIPING

	CAUTION	
Prior to making piping connections, the contractor must thoroughly clean and flush the water loop system. Failure to do so may result in excessive noise, nuisance tripping, and premature component failure.		

Pipework, including piping materials, routing, and installation, shall be protected from physical damage during operation and service and shall comply with applicable national and local codes and standards, including ASHRAE 15, ASHRAE 15.2, the IAPMO Uniform Mechanical Code, the ICC International Mechanical Code, and CSA B52. All field-installed joints shall remain accessible for inspection prior to concealment or enclosure.

1. Flush all field-installed piping prior to connection to remove debris.
2. Open all valves before soldering or brazing (hand valves mid-position; motorized valves manually opened). Use proper heat shields to protect valve bodies.
3. Keep a fire extinguisher readily available when soldering or brazing near the unit.
4. Use proper soldering and brazing techniques to protect valve bodies and unit components.
5. Avoid rapid quenching of soldered joints to prevent joint weakening.
6. Provide for thermal expansion and contraction of piping. Failure to do so may result in damage to piping, fittings, and valves.
7. Do not insulate valve heads or motorized components. Excessive heat buildup can damage valves and impair operation.
8. Consider electrical routing when installing field piping.
9. Comply with all applicable codes and regulations governing piping installation.
10. After completing all connections, pressure test the system and repair any leaks or defective joints. Hydronic systems must be tested with water only; they are not designed to hold pressurized air. Failure to comply may damage the system.



PIPING INSTALLATION



All piping must be properly sized to provide the design water flow required for the specific application and must comply with all applicable codes.



Piping connection sizes on the equipment are not necessarily indicative of the required supply and return line sizes.



On units equipped with plastic drain pans, the drain connection must be hand-tight only.

Chilled water piping must be adequately insulated to prevent condensation and potential property damage. It is also recommended that all piping be insulated when installed in unconditioned spaces to prevent freezing.

	CAUTION	
Do not bend or kink supply lines or hoses. For all supply lines or hoses 1.5" OD or greater, use properly sized fittings to prevent piping damage and potential water flow restriction.		

	ATTENTION	
A minimum entering water temperature of 50.0°F [10.0°C] and adequate water flow are required to prevent freezing. An antifreeze solution must be used for any application where the entering water temperature falls below 50.0°F [10.0°C] or the refrigerant limit is set to 10.0°F [-12.2°C].		
Failure to follow this warning could result in damage to the heat exchanger, equipment, and/or property.		

	ATTENTION	
All manual flow valves used in the system must be ball valves. Globe and gate valves must not be used due to high pressure drop and poor throttling characteristics. Never exceed the recommended water flow rates. Serious erosion or damage of the water to refrigerant heat exchanger could occur.		

	ATTENTION	
Ensure that the Teflon tape used on all threaded connections is compatible with the antifreeze solution used in the water loop.		

The WSV6 water source heat pump is designed to operate with entering liquid temperatures between 50.0–110°F [10.0–43.3°C]. For entering liquid temperatures below 50.0°F [10.0°C], an antifreeze solution is required to prevent freezing. Freeze damage to water coils is not covered under warranty.

	ATTENTION	
Do not allow hoses to rest against structural building components. Compressor vibration may be transmitted through the hoses to the structure, causing unnecessary noise complaints.		

INSTALLATION (CONTINUED)

PIPING INSTALLATION (CONTINUED)

Always check carefully for water leaks and repair appropriately. Units are equipped with female pipe thread fittings. Consult the specification sheets for sizes. Teflon tape should be used when connecting water piping connections to the units to insure against leaks and possible heat exchanger fouling.

Do not overtighten the pipe connections. Flexible hoses should be used between the unit and rigid piping to avoid vibration transmission into the structure.

Ball valves should be installed in the supply and return lines for unit isolation and unit water flow balancing. Pressure/temperature ports are recommended in both the supply and return lines for system flow balancing. Water flow can be accurately set by measuring the water side pressure drop of the water to refrigerant heat exchanger.

Insulation is not required on loop water piping except where piping passes through unconditioned spaces, is installed outside the building, or when loop water temperatures fall below the minimum expected dew point of the surrounding ambient conditions. Insulation is required whenever loop water temperature drops below the dew point to prevent condensation.

Inspect all water connections carefully for leaks and repair as required. Units are equipped with female pipe-thread fittings; refer to the specification sheets for connection sizes. Apply Teflon tape to all threaded water connections to prevent leaks and reduce the potential for heat exchanger fouling. Do not overtighten pipe connections.

LEAK CHECK

After piping installation is complete, leak test the refrigerant piping to confirm that no refrigerant leakage is present.

Pressurize the system with dry nitrogen to a minimum of **200 psig** and hold for **1 hour**. A drop in pressure indicates a leak that must be corrected before proceeding. Do not use leak detectors or solutions that may damage or corrode copper tubing.

Evacuate the suction and liquid lines at the outdoor unit service valves to 500 microns. Once achieved, isolate the vacuum pump and observe the system. The vacuum level shall not exceed 1,500 microns after 10 minutes.

ANTIFREEZE

Antifreeze solutions must be used when low loop temperatures are expected. In areas where entering loop temperatures drop below 50.0°F [10.0°C], or where piping passes through locations susceptible to freezing, antifreeze is required.

Alcohols and glycols are commonly used as antifreeze agents. Freeze protection should be maintained to 15.0°F [8.3°C] below the lowest expected entering loop temperature. For example, if the lowest expected entering loop temperature is 30.0°F [-1.1°C], the leaving loop temperature would be 22.0°F to 25.0°F [-5.6°C to -3.9°C]. Therefore, the freeze protection should be at 15.0°F (30.0°F - 15.0°F = 15.0°F) [-9.4°C (-1.1°C - 8.3°C = -9.4°C)].

ANTIFREEZE CORRECTION FACTORS DATA

Table 8: Antifreeze Correction Factors					
Ethylene Glycol					
	10%	20%	30%	40%	50%
Cooling Capacity	0.995	0.992	0.987	0.983	0.979
Heating Capacity	0.991	0.982	0.977	0.969	0.961
Pressure Drop	1.07	1.13	1.18	1.26	1.28
Propylene Glycol					
	10%	20%	30%	40%	50%
Cooling Capacity	0.990	0.980	0.970	0.960	0.950
Heating Capacity	0.987	0.975	0.962	0.942	0.930
Pressure Drop	1.07	1.15	1.25	1.37	1.42
		Methanol		Ethanol	
	10%	20%	10%	20%	
Cooling Capacity	0.980	0.972	0.991	0.951	
Heating Capacity	0.95	0.97	0.995	0.96	
Pressure Drop	1.023	1.067	1.035	0.96	

INSTALLATION (CONTINUED)

LOW WATER TEMPERATURE CUTOUT SELECTION

The Digital Control Module allows field selection of the low water (or water-antifreeze solution) temperature limit by clipping jumpers JW1 and JW2. This changes the sensing temperature for thermistors CO1 and CO2, respectively. Note that the CO1 thermistor is located on the refrigerant line between the coaxial heat exchanger and the expansion device (TXV). CO1 senses refrigerant temperature, not water temperature, providing a more accurate indication of how water flow and temperature affect the refrigeration circuit.

The factory setting for CO1 is for systems using water, corresponding to a refrigerant temperature of 30.0°F [-1.1°C]. For low water temperature (extended range) applications with antifreeze—such as most ground loops—clip jumper JW1 to adjust the setting to 10.0°F [-12.2°C] refrigerant temperature, which is more appropriate when using an antifreeze solution. All units operating with entering water temperatures below 50.0°F [10.0°C] must include the optional water/refrigerant circuit insulation package to prevent internal condensation.

CAUTION
Disconnect power BEFORE the jumper wires are clipped. Failure to do so could result in equipment and/or property damage.

CONDENSATE DRAINAGE

Condensate drain lines must be installed with a sufficient slope away from the unit to ensure proper drainage. A minimum trap depth of 1.5" is required to isolate the negative pressure in the drain pan from the drain line. Refer to **Figure 10 – Condensate Drainage** for schematic information on the condensate drain lines.

Hose Diameter	Minimum Bend Radius
0.5" [1.3 cm]	5.0" [12.7 cm]
0.75" [1.9 cm]	7.0" [17.8 cm]
1.0" [2.5 cm]	7.0" [17.8 cm]

CAUTION
Check the condensate overflow sensor for proper operation and adjust as required. Final field adjustments are necessary to ensure proper operation and to prevent property damage.

CAUTION
On units equipped with plastic drain pans, tighten the drain connection by hand only.

CAUTION
Both the supply and return water lines may sweat when exposed to low water temperatures. Insulate these lines to prevent condensation and potential property damage.

CAUTION
Units equipped with an economizer require a separate, externally trapped drain line for condensate removal.

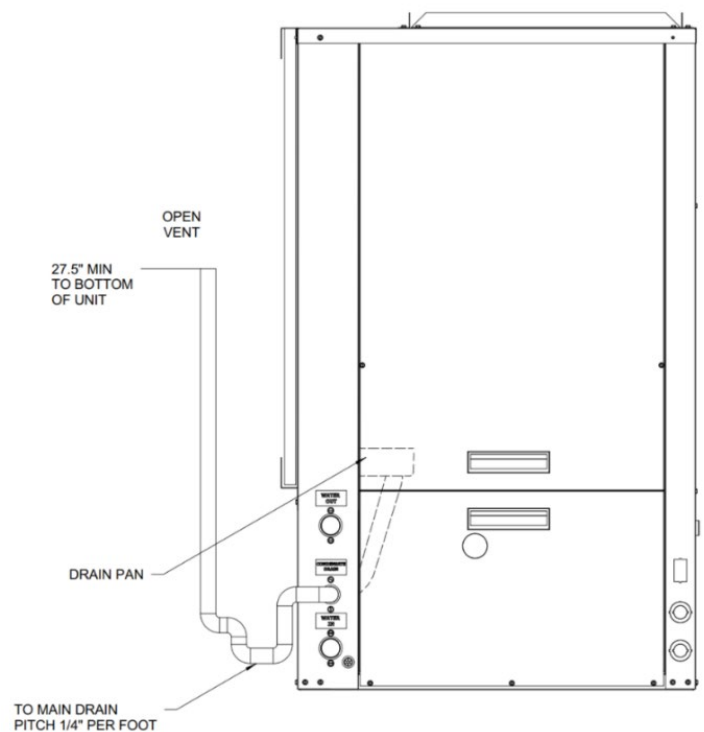

Figure 10 - Condensate Drainage

INSTALLATION (CONTINUED)

DUCTWORK

Discharge ductwork is typically used with these units. When return air ductwork is required, the unit is supplied with a 1.0" filter rack/duct collar for connection to the return air duct system. All ductwork must be installed in accordance with National Fire Protection Association (NFPA) Codes 90A and 90B. Supply and return ducts must be properly sized to remain within the unit's external static pressure limitations. Ductwork should be adequately insulated to prevent condensation and minimize heat loss. A flexible connector is recommended for supply air connections on metal duct systems.

DISCHARGE DUCTING

All ductwork shall conform to industry standards of good practice as outlined in the ASHRAE System Guide. A field-supplied discharge duct system typically consists of a flexible connector at the unit, a non-insulated transition piece to the full duct size, an elbow without turning vanes, and a trunk duct branching to distribution diffusers, as shown in **Figure 11 – Discharge Ducting**. The transition piece shall not exceed a 30° angle, as steeper transitions can result in significant airflow loss.

Do not connect full-size ductwork directly to the unit discharge collar without first using a transition sized to the unit discharge opening. For metal duct systems, the elbow sides and the entire branch duct should be internally lined with acoustic insulation to reduce sound transmission. Glass fiber duct board provides higher sound absorption and may allow omission of the flexible connector. Duct layout shall be arranged to prevent a direct line of sight between the unit discharge and the supply diffusers.

RETURN AIR DUCTING

Return air may be ducted to the unit through a wall louver. The return air duct system typically consists of a flexible connector at the unit and a trunk duct connected to the return air louver. For metal duct systems, the return air duct should be internally lined with acoustic insulation to reduce sound transmission. Glass fiber duct board provides greater sound absorption and may allow omission of the flexible connector.

A 1.0" duct collar flange is provided on the filter rack for ducted return air applications. A flexible duct collar may be installed between the duct transition and the return air ductwork. The return air duct transition must be the same size as the return air coil face area (as shown in **Figure 12 – Return Air Ducting**).

CAUTION
Carefully follow all instructions and recommendations provided with the filter rack kit.

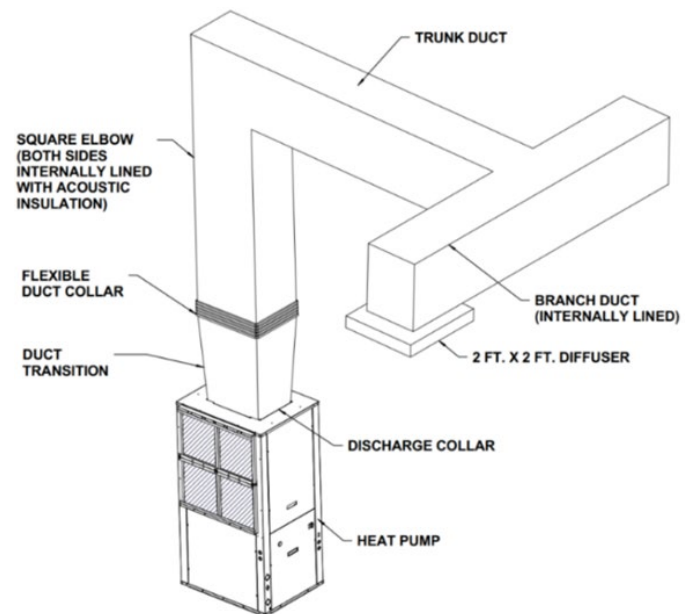

Figure 11 – Discharge Ducting

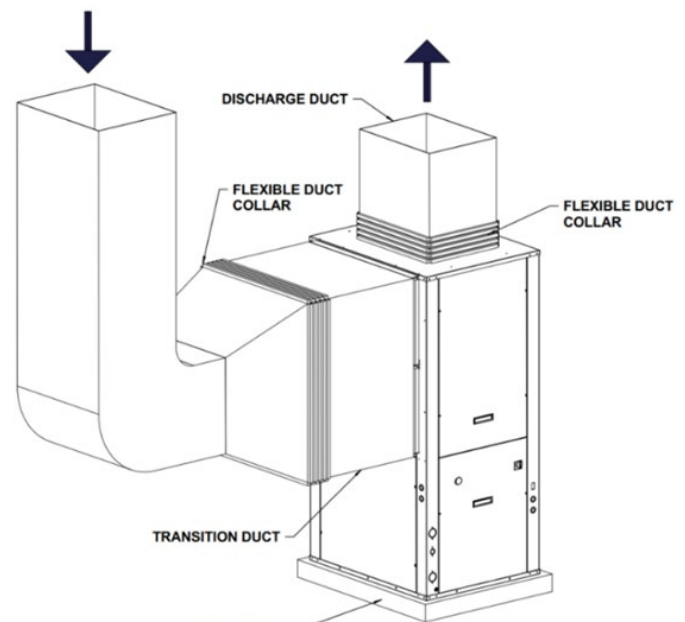

Figure 12 – Return Air Ducting

REFRIGERANT CHARGING

WARNING

FIRE OR EXPLOSION HAZARD

Failure to follow this warning may cause personal injury, death, and/or property damage.

Do not use flames or ignition sources when leak checking refrigerant tubing or components.

ATTENTION

Any metering device installed in the refrigerant circuit must be compatible with the type of refrigerant in use.

Use appropriate personal protective equipment (PPE) when handling refrigerant. Consider all relevant factors when determining charging method and refrigerant quantity, including ambient conditions, factory charge, refrigerant line size and length, and metering device type.

WARNING

IMPROPER HANDLING OF REFRIGERANTS CAN RESULT IN SERIOUS INJURY, EXPLOSION, OR DEATH.

- In the event of a suspected indoor refrigerant leak, ensure the area is adequately ventilated prior to servicing.
- Refrigerant shall not be purged or released into enclosed interior spaces.

WARNING

Refrigerant released into an enclosed space can displace oxygen and may result in unconsciousness or death. If an indoor refrigerant leak is suspected, thoroughly ventilate the area before performing any work.

Do not purge or allow refrigerant to be released into an interior space.

Contact with liquid refrigerant can cause frostbite or blindness; avoid skin and eye contact and always wear appropriate protective goggles and gloves when handling refrigerants. Seek immediate medical attention if refrigerant contacts the skin or eyes.

Never burn refrigerant, as doing so produces highly toxic gases.

WARNING

It is a violation of federal law to discharge refrigerant into the atmosphere. Always use approved reclaiming methods and certified equipment when installing or servicing this unit. A qualified agency must perform this service. A sealed refrigerant system is designed to be closed and self-contained and typically requires no routine maintenance.

WARNING

Only EPA-certified technicians are permitted to handle refrigerants. In Canada, technicians must be ODP/ODS certified. Follow all applicable regulations.

FLAMMABLE REFRIGERANT LEAK DETECTION

Never use ignition sources when searching for or detecting refrigerant leaks. Halide torches or any detectors using a naked flame are strictly prohibited.

If a leak is suspected:

- Extinguish all naked flames in the area.
- For leaks requiring brazing, recover all refrigerant from the system or isolate it using shut-off valves in a section of the system remote from the leak.

Acceptable refrigeration leak detection methods are as follows:

- Electronic Leak Detectors:** Electronic detectors may be used to locate refrigerant leaks. For flammable refrigerants, ensure the detector sensitivity is appropriate for the refrigerant type and that the instrument is recalibrated as required. Calibration shall be performed in a refrigerant-free environment. The detector shall be non-sparking and suitable for the refrigerant being used. Detection equipment shall be set to a percentage of the refrigerant Lower Flammability Limit (LFL), not exceeding 25%. Calibration gas shall correspond to the refrigerant in use.
- Leak Detection Fluids:** Bubble solutions and fluorescent detection agents are acceptable for leak detection. Do not use chlorine-containing detergents or chemicals, as these may react with refrigerant and cause corrosion of copper tubing.

This ensures safe detection and handling of flammable refrigerants during maintenance or servicing.

REFRIGERANT CHARGING INSTRUCTIONS

When charging the system in cooling mode, ensure the ambient temperature is 60.0°F [15.6°C] or higher. Operate the system for a minimum of 15 minutes between adjustments to allow the pressures to stabilize.

TXV CHARGING

- Charge AC units to achieve **12.0°F [6.7°C] subcooling**. Charge heat pump units to achieve **10.0°F [5.6°C] subcooling**.
- If the system is equipped with an adjustable valve, adjust to achieve 10.0°F [15.6°C] superheat.

If the system is undercharged after the initial charge, add refrigerant until the recommended pressures, temperatures, sub-cooling, and superheat are achieved. If the system is overcharged, recover refrigerant until these values are within recommended limits.

CONTROLS

SEQUENCE OF OPERATION

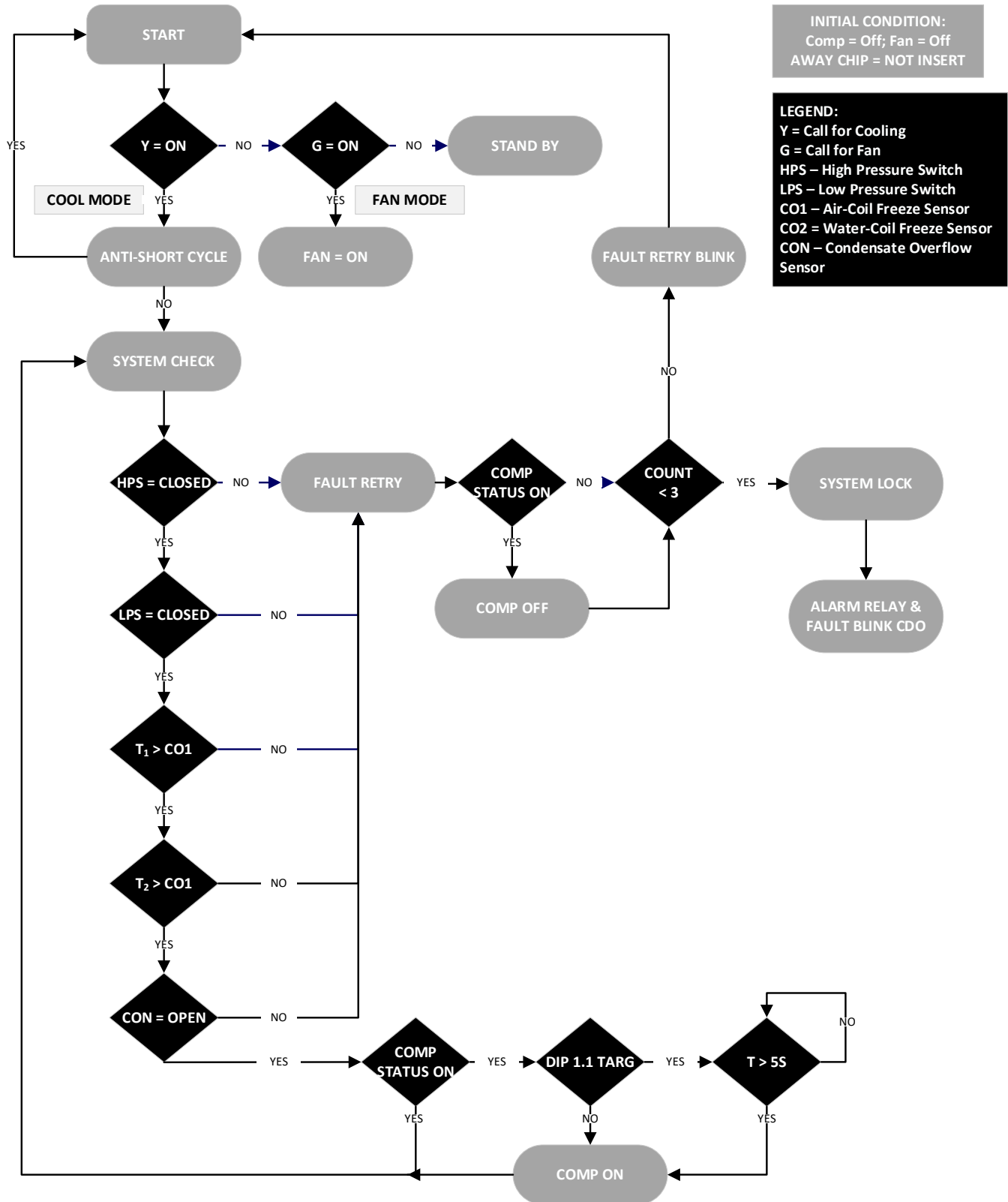

Figure 13 - Sequence of Operations

First Co. / AE-Air reserves the right to change, alter, or update data, design features, and specifications without prior notice.

CONTROLS (CONTINUED)

WSCM CONTROL MODULE CONTROL FEATURES

- Anti-short Cycle Protection
- Random Start
- High and low Pressure Cut-out
- Water Coil Low Temperature Cut-out
- Over/Under Voltage Protection (non-DDC only)
- Fault Retry
- Lockout with Soft and Hard Reset
- Condensate Overflow Sensor
- Diagnostic LED Display (non-DDC only)
- Test Mode
- Alarm Relay
- Accessory Relays
- Vacated Mode
- Extended Compressor Operating Monitoring

STANDARD OPTION WITH DDC CONTROL

The WSV6 unit is available with a DDC control option and is BMS-ready via BACnet MS/TP communication. Refer to IOM8083D02 for detailed information on the DDC controller.

MOTOR SPEED OPERATION

An ECM blower may be driven directly by the WSCM. Blower operation and speed are controlled by the WSCM based on the G, Y1, and O input signals. Blower speed is automatically adjusted to match the operating mode.

Table 10: ECM Fan Control

Unit Call	Fan Speed
G	G1
Y1, O	G1, G2, G3
Y1	G1, G2, G3

Table 11: Motor Speed – Normal Dual-Stage Operation

Mode	Unit Call	Fan Speed
Fan only	G	G1
Low Cool	Y1, O	G1, G2
Low Heat	Y1	G1, G2
High Cool	Y1, Y2, O	G1, G2, G3
High Heat	Y1, Y2	G1, G2, G3
Aux Heat	W/H, Y1	G1, G2, G3

Table 12: Motor Speed – Dual-Stage Dehumidification Operation

Mode	Unit Call	Fan Speed
Fan only	G	G1
Low Cool	Y1, O	G1
Low Heat	Y1	G1, G2
High Cool	Y1, Y2, O	G1, G2
High Heat	Y1, Y2	G1, G2, G3
HGRH	W/H, Y1	G1, G2

Table 13: Motor Speed – Normal Single-Stage Operation

Mode	Unit Call	Fan Speed
Fan only	G	G1
Cool	Y1, O	G1, G2, G3
Heat	Y1	G1, G2, G3
Aux Heat	W/H, Y1	G1, G2, G3

Table 14: Motor Speed – Single-Stage Dehumidification Operation

Mode	Unit Call	Fan Speed
Fan only	G	G1
Cool	Y1, O	G1, G2
Heat	Y1	G1, G2, G3
HGRH	W/H, Y1	G1, G2

FIELD-ADJUSTABLE FUNCTIONS

Test Mode

The unit can be placed in test mode by shorting the test pins on the WSCM. When the pins are shorted, the module enters a test mode period during which all time delays operate at 15x normal speed. While in test mode, the yellow LED2 indicator will illuminate.

Stored faults can be cleared by entering and then exiting test mode, or by performing a hard reset. To exit test mode, short the test pins for approximately 3 seconds.



ATTENTION



During test mode, the control will verify that the CO1 and CO2 freeze thermistors are properly installed and functioning. If either CO1 or CO2 is open, or if a jumper is detected across the freeze sensor terminals, the control will display Fault Code 19.



ATTENTION



Test mode will be automatically exited after a 10-minute period.

CONTROLS (CONTINUED)

FIELD-ADJUSTABLE FUNCTIONS (CONTINUED)

Vacated Premises Control

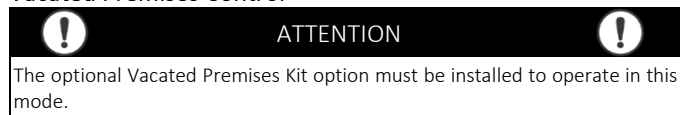

The Vacated Premises operating mode is intended for extended periods of unoccupancy. In this mode, the heat pump operates in cooling mode for a predetermined cycle time to help maintain indoor air conditions. Cycle time selection is set using DIP switch 1.7 and may be configured for 1-hour or 2-hour operation.

During Vacated Premises operation, the control stores all faults detected over a 24-hour period. If the same fault is recorded for four consecutive days, the unit will enter a hard lockout condition.

The Vacated Premises control kit includes a rocker switch, wiring, and a programmed chip. The chip is installed on the WSCM module and must be installed by a licensed contractor.

- Home Selection
If the switch is in the HOME position, the heat pump will operate in its normal mode.
- Away Selection
When the switch is placed in the AWAY position, the heat pump and thermostat are forced into COOL mode. The heat pump operates in accordance with the thermostat setpoint and control logic.

In addition, the heat pump will automatically cycle in cooling mode for 15-minute run intervals four (4) or eight (8) times per day, based on the DIP switch 1.7 setting. The thermostat retains priority and may initiate additional cooling operation as required.



Refer to **IOM L25482** for the non-DDC Vacated Premises control option.

Refer to **IOM VSDDCK** for the DDC Vacated Premises control option.

Boilerless Control

The system may be configured for boilerless operation by setting DIP switch 1.5. If the CO1 temperature falls below the setpoint selected by DIP switch 1.6, the compressor is de-energized and the control transitions to emergency heat mode, staging on W1. To prevent nuisance cycling, the compressor is locked out for 60 minutes following this event.

The boilerless changeover temperature setpoint is adjustable using DIP switch 1.6.

Water-Coil Low Temperature Cut-Out Limit

Jumpers JW1–CO1 allow field selection of the low-temperature cutout limit for CO1 as follows:

- Not clipped: 30.0°F [–1.1°C]
- Clipped: 10.0°F [–12.2°C]

Alarm Relay Setting

Jumper JW3 (Alarm) provides field selection of the AL2 alarm relay output. The jumper may be configured to supply 24 VAC or to provide dry contacts. The alarm relay is energized when the unit is in a lockout condition.

- Not clipped: AL2 connected to R (24 VAC)
- Clipped: AL2 dry contacts (no voltage)

Dehumidification Mode

When DIP switch 1.4 is enabled, the unit operates in DEHUMIDIFICATION (DEHUM) mode. In DEHUM mode, blower speeds are reduced during cooling operation to enhance moisture removal. The W/H input to the control board is used to drive the hot gas reheat (HGRH) circuit through the W1 output relay. The W1 relay is energized only when a W/H input and an O (cooling) input are present and the compressor is operating.

When DIP switch 1.4 is disabled, the unit operates in NORMAL (NORM) mode. In this mode, blower speeds operate at normal values, and the W/H input to the control board is used to control electric heat through the W1 relay. In NORM mode, the W1 relay is energized only when a W/H input is present without an O input and the compressor is operating.

WSCM SAFETY FEATURES

Anti-Short-Cycle Protection

The WSCM module provides a 5-minute anti-short-cycle delay to prevent rapid compressor cycling.

Random Start

Upon a call for operation, the WSCM module initiates a random start delay of 5–80 seconds.

CONTROLS (CONTINUED)

WSCM SAFETY FEATURES (CONTINUED)

Fault Retry

The control module includes a fault retry function that permits up to two (2) automatic restart attempts following an initial fault condition. During fault retry operation, the LED display indicates “rE” and the associated numeric fault code.

Water-Coil Low Temperature Cut-Out (CO1)

The control module shall declare a CO1 low-temperature fault during a compressor run cycle under either of the following conditions:

- The CO1 thermistor temperature is below the selected temperature limit.
- The CO1 thermistor temperature rise rate is less than 2.0°F [-16.7°C] per 30 seconds.

To prevent nuisance trips, the CO1 input is bypassed during initial compressor operation as follows:

- Initial run: 120 seconds
- First retry: 90 seconds
- Second retry: 60 seconds

Air Coil Low Temperature Cut-Out (CO2)

The control module shall declare a CO2 low-temperature fault during a compressor run cycle under either of the following conditions:

- The CO2 thermistor temperature is below the selected temperature limit.
- The CO2 thermistor temperature rise rate is less than 2.0°F [-16.7°C] per 30 seconds.

The CO2 input shall be bypassed for 120 seconds following compressor startup.

Condensate Overflow Sensor

The condensate overflow sensor shall detect an overflow condition for 30 continuous seconds before a COF fault is declared. The sensor shall be monitored at all times. Upon detection of a COF fault, any operating compressor and/or fan shall be de-energized.

Low Pressure Protection

The control board shall monitor the low-pressure (LP) switch input. If the LP switch opens for 30 continuous seconds during a compressor run cycle (Y1 = ON), the CC relay shall be de-energized and the unit shall enter lockout mode.

If the LP switch input remains open for 30 continuous seconds prior to a compressor run cycle, the control board shall enter lockout mode.

The LP switch input shall be bypassed for the first 30 seconds of each compressor run cycle. The LED display shall indicate a retry or lockout status and the associated fault code.

Lockout Mode

While in lockout mode, the LED display shall indicate “Lo” and the associated numeric fault code. During lockout mode, the CC relay shall be inhibited from energizing and the AL1 alarm relay shall be energized.

Lockout mode may be cleared by entering test mode or by performing a hard reset via the power disconnect.

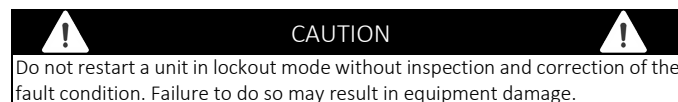

Extended Compressor Operation Monitoring

If the compressor relay remains energized for four (4) continuous hours, the control module shall automatically de-energize the compressor relay and initiate the anti-short-cycle delay.

All applicable safety devices shall remain monitored during the off period. If normal operating conditions are verified and a compressor demand remains present, the control module shall re-energize the compressor relay following completion of the delay.

Over/Under Voltage Shutdown

If an over-voltage or under-voltage condition is detected for more than 10 continuous seconds, the control module shall initiate a shutdown. The over/under-voltage shutdown is self-resetting. Normal operation shall be restored automatically when the supply voltage returns to the acceptable range of 18.5–31.0 VAC. This condition is not classified as a fault.

If the WSCM remains in an over/under-voltage shutdown condition for 15 minutes, the alarm relay shall be energized.

CONTROLS (CONTINUED)

CONTROL PANEL

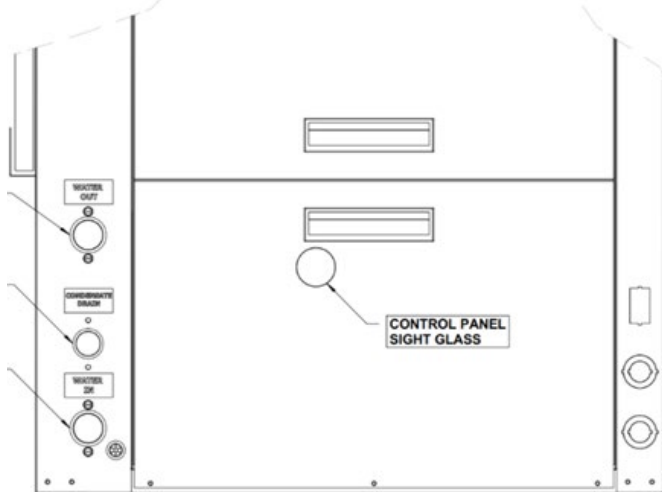

Figure 14 - Control Panel Sight Glass Location

CONTROL BOX DETAIL

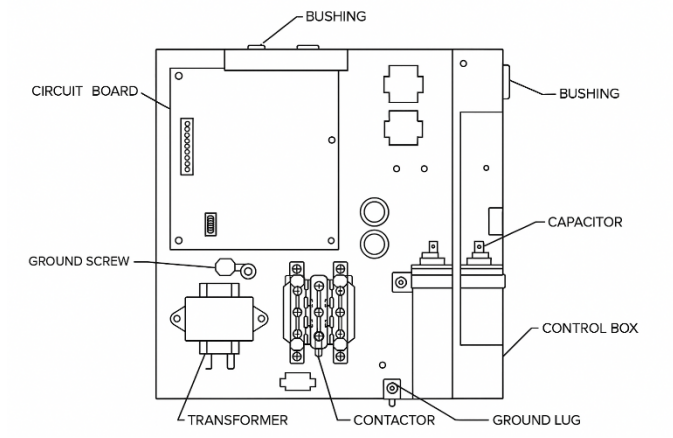

Figure 17 - Control Box Layout

BLOWER SPEED CONTROL

Units equipped with a direct-drive (ECM) blower motor provide three selectable speeds: Low (X1), Medium (X2), and High (X1+X2). Refer to **Table 17: Blower Data** for airflow performance at various external static pressures. Select blower speed based on required airflow and system external static pressure.

Due to reduced airflow at the Low (X1) setting, continuous operation in heating or cooling is not recommended. Low speed is intended only for the initial 10-minute startup period.

When Medium (X2) speed is selected, the blower will operate at Low (X1) speed for the first 10 minutes after startup, then automatically transition to Medium (X2).

When High (X1+X2) speed is selected, the blower will operate at Low (X1) speed for the first 10 minutes after startup, then automatically transition to High (X1+X2).

Units are factory wired for High (X1+X2) speed operation. Refer to Note 10 in the wiring diagram; jumper modification may be required to select Medium speed.

!
ATTENTION
!

High-efficiency brushless DC motors remain energized whenever power is supplied. Motor operation is regulated by low-voltage thermostat inputs and control board logic.

BLOWER SPEED CONTROL

NOTE: CONTROL BOARD DIP SWITCH 1-2 MUST BE IN ON POSITION, "DC"

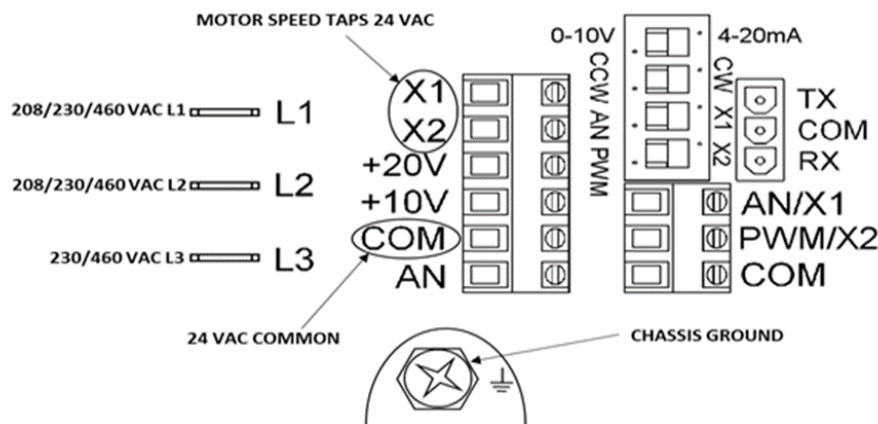

Figure 18 - Motor Connections

CONTROLS (CONTINUED)

A2L REFRIGERANT SENSING AND MITIGATION

Units containing more than 4.0 lb [1.8 kg] of R-454B (A2L) refrigerant are factory equipped with a refrigerant leak detection system installed at the evaporator coil, in accordance with UL 60335-2-40 requirements.





Upon detection of refrigerant concentration exceeding the sensor threshold, the control system shall automatically:

1. De-energize the compressor, and
2. Energize the evaporator fan to dilute and disperse leaked refrigerant within the occupied space.

The unit shall remain in refrigerant mitigation mode until the refrigerant concentration falls below the detection threshold and for a minimum duration of 5 minutes.

After the mitigation period has elapsed and no refrigerant is detected, the unit shall automatically return to normal operation based on the active thermostat inputs.

A visual LED status indicator is provided on the refrigerant sensor for diagnostic and service verification. Refer to the Troubleshooting section for LED status definitions.

	WARNING	
	ELECTRIC SHOCK HAZARD	
<p>Before servicing or performing maintenance on the system, turn OFF the main power to the unit. Failure to do so may result in electrical shock, causing personal injury or death.</p>		
<p>Note: The unit may be supplied by multiple power sources.</p>		





CONTROL BOX REMOVAL

Disconnect and lock out all electrical power before servicing. Failure to do so may result in serious injury or death.

1. Verify that all electrical power to the unit is disconnected and that the local disconnect is locked out.
2. Using a 1/4" [6.4 mm] hex-head driver, remove the fasteners securing the front electrical panel.
3. Remove the front electrical panel to access the electrical enclosure.
4. Disconnect all electrical harnesses.
5. Remove the two 1/4" [6.4 mm] hex-head fasteners securing the electrical enclosure to the base and side panels.
6. Remove the electrical enclosure from the unit.

CONTROL BOX ASSEMBLY

1. Reinstall the electrical enclosure in the unit and secure it to the base and side panels using the original fasteners.
2. Reconnect all electrical harnesses.
3. Reinstall the front electrical panel and tighten all fasteners securely.

	WARNING	
	ELECTRIC SHOCK HAZARD	
<p>Disconnect electrical power before servicing the equipment.</p>		

CONTROLS (CONTINUED)

CONTROL BOARD LAYOUT

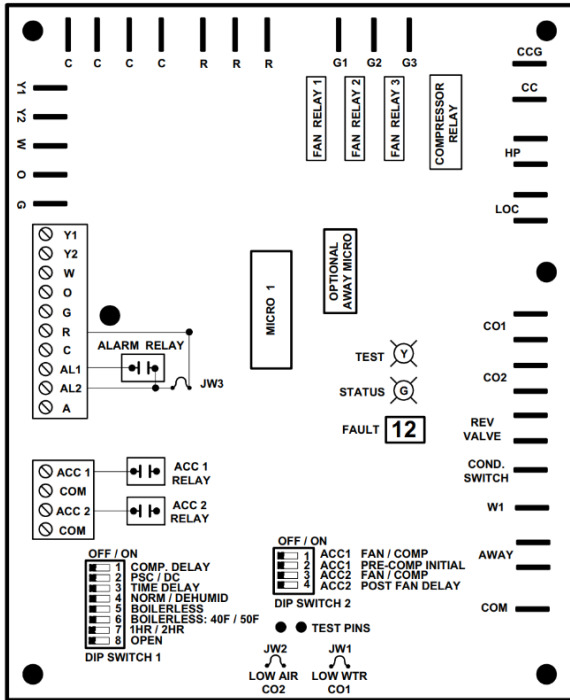

Figure 16 - Control Board Layout

Table 15: Control Board Layout

Connection	Input or Output	Description
R	--	24 VAC
C	--	24 VAC (Grounded Common)
Y1	I	Call for Compressor
W	I	Call for Heating or Emergency Heat
O	I	Call for Reversing Valve in Cooling
G	I	Call for Fan Operation
AL1	O	Thermostat Fault Light – 24VAC or Dry Contact
AL2	O	Alarm Relay – 24VAC or Dry Contact
A	O	Water Solenoid Valve – Paralleled with Compressor Contactor
ACC1	O	Accessory Relay 1 – 24 VAC
ACC2	O	Accessory Relay 2 – 24 VAC
G1	O	Low Fan Speed Operation
G2	O	Medium Fan Speed Operation
G3	O	High Fan Speed Operation
CC	O	Compressor Contactor
CCG	O	Common Compressor Contactor
HP	I	High Pressure Switch
LOC	I	Low Pressure Switch
CO1	I	Water Coil Low Temperature Thermistor
CO2	I	Air Coil Low Temperature Thermistor
RV	O	Reversing Valve Output
COND_SW	I	Condensate Overflow
W1	O	Electric Heat
COM	--	Grounded Common

Table 16: Controller Operation Codes

Description	LED Readout
Normal Mode	ON (Green Light)
Controller Non Functional	OFF (Green Light)
Test Mode (pins shorted momentarily)	ON (Yellow Light)
Standby	ST
Fan Only (G active)	Fo
Cool (Y1 & O active)	Co
Heat 1st Stage (Y1 active)	H1
Accessory Relay 1	A1
Accessory Relay 2	A2
Vacated Premises Control	Ay
Fault Retry	rE & CODE #
Lockout	Lo & CODE #
Over/Under Voltage Shutdown	Ou & CODE #
Temperature Sensor Error	SE & CODE #
Test Mode – No Fault	11
Test Mode – HP Fault	12
Test Mode – LP Fault	13
Test Mode – CO1 Fault	14
Test Mode – CO2 Fault	15
Test Mode – Cond. Overflow Fault	16
Test Mode – Over/Under Shutdown	17
Test Mode – Swapped CO ₁ /CO ₂ Thermistors	18
Test Mode – Temperature Sensors	19

Table 17: Dip Switch Functions

Switch	Function	Off	On
Dip Switch 1			
1.1	Compressor Delay	No Delay	5s Delay
1.2	Motor Type	PSC Motor	ECM Motor
1.3	Blower Time Delay	None	45s
1.4	Dehumidification	None	Dehum
1.5	Boilerless	Off	On
1.6	Boilerless Setpoint	40°F	50°F
1.7	Vacated Premises	1hr	2hr
Dip Switch 2			
2.1	Accessory Relay Control	With Fan	With Comp
2.2	Compressor Delay	None	60s
2.3	Accessory Relay 2 Control	With Fan	With Comp
2.4	Fan Delay	None	30s

First Co. / AE-Air reserves the right to change, alter, or update data, design features, and specifications without prior notice.

CONTROLS (CONTINUED)

ELECTRONIC TEMPERATURE (ECONOMIZER) CONTROL

ATTENTION

The electronic temperature controller shall be configured prior to initial unit startup to ensure economizer parameters are properly entered.

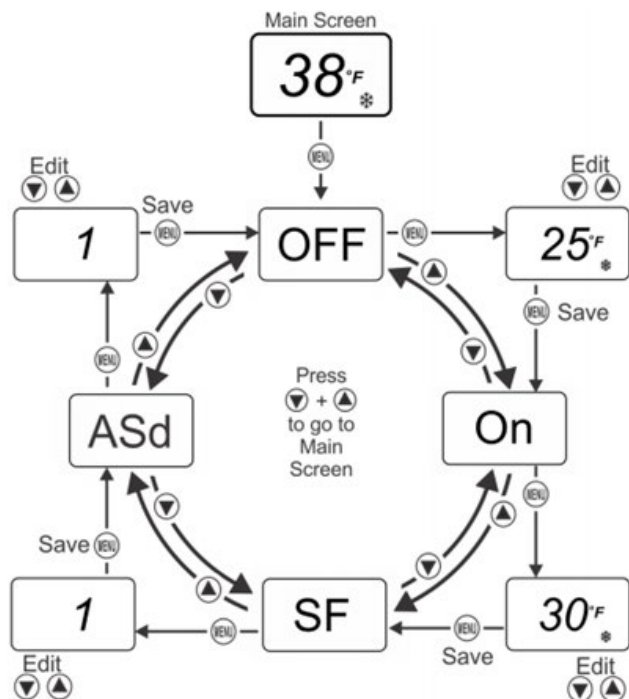

Figure 15 - Electronic Temperature Controller

ACCESSING & ADJUSTING BASIC MENU PARAMETERS

To access the Basic menu and view or modify Basic parameter values, perform the following steps:

1. From the Main screen, press MENU. The LCD will display OFF, the first parameter code in the Basic menu.
2. Press UP or DOWN to scroll through the available Basic parameter codes until the desired code is displayed.
3. With the desired parameter code displayed, press MENU to view the current parameter value.
4. Press UP or DOWN to scroll through the available values for the selected parameter until the desired value is displayed.
5. Press MENU to save the displayed value and advance to the next parameter code.
6. To exit the Basic menu and access the Advanced menu, press and hold UP or DOWN simultaneously for 5 seconds.

Relay Off Temperature (Off)

Sets the temperature at which the 3-way valve is de-energized and the unit returns to cooling mode. When the controller reaches the Relay OFF temperature, the green LED shall turn OFF.

The recommended setting is 50.0–55.0°F [10.0–12.8°C].

Relay On Temperature (On)

Sets the temperature at which the 3-way valve is energized and the unit enters economizer mode. When the controller reaches the Relay ON temperature, the green LED shall turn ON.

The recommended setting is 40.0–45.0°F [4.4–7.2°C].

ECONOMIZER MODES OF OPERATION

Anti-Short Cycle Delay (Asd)

Sets the minimum time that the output relay remains de-energized before the next on-cycle is permitted. When an ASD value greater than 0 is selected, relay operation is inhibited during the delay period, preventing energization of the 3-way valve. The ASD timer shall initiate at controller power-up and at the start of each off-cycle. The recommended setting is 3.

Sensor Failure Mode (Sf)

Defines controller operation in the event of a sensor failure. This parameter shall be set to 0.

Table 18 - Recommended Control Parameters		
Code	Description	Parameter
Un	Relay Off Temperature	55
Off	Relay On Temperature	45
On	Anti-Short Cycle Delay	3
SO	Sensor Failure Mode	0

APPLICATION

In cooling mode, heat is rejected from the heat pump's refrigerant into the water loop. A cooling tower and/or boiler may be required to maintain proper loop temperature. For open cooling tower systems, chemical water treatment is mandatory to prevent corrosion and maintain water quality.

In heating mode, heat is absorbed from the water loop into the heat pump's refrigerant. A boiler may be used to maintain proper water temperature within the loop.

CAUTION

Failure to maintain proper water loop temperatures may result in equipment failure, property damage, and voided warranties.

CAUTION

The manufacturer does not warrant equipment subjected to abuse. Dirt, piping chips, or other foreign material may contaminate the water and cause heat exchanger failure.

UNIT CONNECTION AND WATER SYSTEM PREPARATION

Do not connect the unit to the supply or return piping until the water system has been thoroughly cleaned and flushed to remove dirt, pipe chips, or other foreign materials. During flushing, connect the supply and return hoses together to ensure the entire system is properly cleared. After cleaning and flushing, connect the unit to the water loop and adjust all valves to achieve the proper flow rate. The nominal flow rate is 3.0 GPM [0.01 m³/sec] per 12,000 BTUH [3.5 kw] of cooling.

EXTENDED RANGE OPERATION

Piping systems expected to operate with water temperatures below 50.0°F [10.0°C] require using the extended range option. This includes closed-cell insulation on all piping surfaces to prevent condensation. Ensure sufficient antifreeze is used to protect the water loop and condenser coil from freezing. Frozen condenser coils are not covered under warranty. A boiler may be required to maintain the minimum water temperature within the loop.

CLOSED LOOPS

When a secondary heat exchanger is used (i.e., plate to plate; closed loop system) it is imperative that all air is purged from the system to prevent condenser fouling.

CAUTION

The entire water loop must be thoroughly cleaned and flushed of all debris before making final connections and operating the unit.

Adjust all valves to provide the proper water flow rate for the unit.

Failure to comply will void all factory warranties.

OPEN LOOPS

Open-loop applications utilize a direct water source, such as a well, lake, or cooling tower, to supply water to the heat pump. Because the water is exposed to environmental conditions, these systems require careful evaluation of water quality, flow stability, and potential fouling or corrosion risks. Materials compatible with the water source, such as cupronickel heat exchangers, may be required. Open-loop systems shall incorporate proper filtration, water treatment, and disposal methods in accordance with local codes and environmental regulations. Adequate flow control and periodic inspection are essential to maintain performance and prevent scaling, biological growth, or debris accumulation that could impair heat exchanger operation.

To achieve optimal system performance in cooling tower/boiler loop applications, maintain loop water temperature between 55.0°F [12.8°C] and 75.0°F [23.9°C] in heating mode and 60.0°F [15.6°C] and 95.0°F [35.0°C] in cooling mode. Operation outside these ranges may reduce efficiency or affect capacity.

APPLICATION - ECONOMIZER

OVERVIEW

In large commercial buildings, simultaneous heating and cooling demands commonly occur during winter and shoulder seasons. To balance these varying loads, a waterside economizer can be used to provide “free” cooling to spaces that require it. Water-source heat pumps serving interior or exterior zones extract heat from the building’s water loop to provide heating. The resulting chilled water can then be utilized for cooling by routing the fluid through the economizer coil.

FEATURES AND BENEFITS

The Hydrotech WSV6 waterside economizer option is a modular hydronic cooling coil that utilizes the building water loop to provide “free” cooling to the conditioned space.

The economizer operates by monitoring the entering water temperature to the water-source heat pump. When the entering water temperature drops below a configurable setpoint, the control system disables compressor operation and diverts the chilled water through the economizer coil to provide cooling without mechanical refrigeration.

ASHRAE Standard 90.1, Energy Standard for Buildings, requires water-source heat pumps with capacities greater than 54,000 BTUH to be equipped with a waterside economizer. In jurisdictions where ASHRAE 90.1-2019 has been fully adopted, the Hydrotech WSV6 waterside economizer option meets all applicable economizer requirements for water-source heat pump systems.

ECONOMIZER PERFORMANCE DATA

Unit	Airflow SCFM	Flowrate GPM	ΔP ft H ₂ O	Coil ΔP in. w.c.
WSV6048	1,200	6	1.5	0.18
	1,400	9	3.3	0.22
	1,600	12	5.7	0.28
WSV6060	1,500	7.5	1.8	0.15
	1,750	11.3	3.8	0.19
	2,000	15	6.5	0.23
WSV6072	1,200	9	2.5	0.21
	1,400	13.5	5.3	0.27
	1,600	18	9.2	0.32

NOTE: Pressure drop measured at 45.0°F [7.2°C] EWT

For optimal economizer coil performance, the entering water temperature (EWT) should be maintained between 40.0–50.0°F [4.4–10.0°C]. Entering water temperatures above 50.0°F [10.0°C] will reduce economizer effectiveness. The electronic temperature sensor is factory set to a default setpoint of 45.0°F [7.2°C].

The economizer coil adds a significant amount of external static pressure to the unit blower system. To ensure adequate airflow, refer to **Table 19: Economizer Performance**.

APPLICATION - HOT GAS REHEAT

OVERVIEW

Because ventilation air is introduced into buildings, indoor air quality (IAQ) and relative humidity (RH) are critical considerations when selecting heating and cooling equipment. With the Hydrotech WSV6 hot gas reheat dehumidification option, return air from the conditioned space is first cooled by a dedicated air-to-refrigerant coil and then reheated by a hot gas reheat coil. This process allows precise space temperature control while reducing space relative humidity. Lower relative humidity levels also contribute to improved indoor air quality.

ON/OFF HOT GAS REHEAT OPERATION

The Hydrotech WSV6 hot gas reheat dehumidification option is equipped with DDC controls and is BMS-ready via **BACnet MS/TP** communication. Refer to **IOM8083D01** for detailed information on the DDC controller.

In addition to the DDC controller, the hot gas reheat dehumidification system includes a reheat coil (mounted on the leaving-air side of the indoor air coil), a reheat valve, and a bleed-off valve. With this option, return air from the space is conditioned by the indoor air-to-refrigerant coil and then reheated by the reheat coil to deliver neutral air conditions to the space. Hot gas reheat dehumidification operates only during the cooling cycle.

DEHUMIDIFICATION OPERATION

When the space sensible temperature setpoint is satisfied (thermostat satisfied) but the space relative humidity remains above the humidity setpoint (dehumidistat not satisfied), the unit operates in dehumidification mode. The reheat valve energizes, allowing high-pressure refrigerant gas to flow from the compressor through the reversing valve.

The high-pressure, high-temperature refrigerant is divided into two flow paths. One path directs refrigerant through the reheat valve and reheat coil to increase the leaving air temperature. The second path routes refrigerant through the coaxial heat exchanger. The two-phase refrigerant exiting the reheat coil and the liquid refrigerant exiting the coaxial heat exchanger are mixed before entering the evaporator, where dehumidification occurs.

Dehumidification operation terminates when either the dehumidistat is satisfied or a demand for space sensible cooling is present. If a sensible cooling demand exists, the unit transitions to normal cooling mode.

WATER QUALITY REQUIREMENTS

Units are supplied with either copper or optional cupro-nickel water-to-refrigerant heat exchangers. Copper heat exchangers are suitable for groundwater with low mineral content. If water quality concerns exist, or if advised by a well driller, water testing is recommended to verify suitability for water-source equipment. For applications with moderate scaling potential or brackish water conditions, a cupro-nickel heat exchanger is recommended.

WATER WELL APPLICATION REQUIREMENTS:

- 50.0°F [10.0°C] Minimum Entering Water Temperature
- Cupronickel Refrigerant Heat Exchanger

When a water well is used exclusively to supply water to the heat pump, a cupronickel refrigerant heat exchanger is required. The well pump shall be interlocked to operate only when the heat pump is operating. A 24 VAC contactor may be wired to the ACC1 terminal on the control module.

The ACC1 output can be configured to energize prior to or simultaneously with compressor start-up, thereby energizing the well pump whenever the heat pump is in operation.

CAUTION

The minimum entering water temperature is 50.0°F [10.0°C]. Failure to follow this requirement may result in equipment failure and property damage.

CAUTION

Open-loop and pond applications require specialized design knowledge. Installation shall be performed only by licensed installers who have received specialized training.

ATTENTION

The discharge water from the heat pump is not contaminated and may be disposed of in accordance with applicable local codes and regulations.

Table 20: Water Quality Requirements

Potential Failure Mode	Water Chemistry Parameter	Copper	CuNi
Corrosion and Scaling	pH Level	7.0-9.0	7.0-9.0
	Hardness (Calcium or Magnesium Carbonate)	< 350.0 ppm	<350.0 ppm
	Langelier Saturation Index (LSI)	-0.5 to 0.0	-0.5 to 0.0
	Ryznar Stability Index (RSI)	6.2 – 6.8	6.20 – 6.80
	Hydrogen Sulfide	< 0.5 ppm	< 0.5 ppm
	Sulfates	< 125.0 ppm	< 125.0 ppm
	Chlorine	< 0.5 ppm	< 0.5 ppm
	Chlorides	< 20.0 ppm	< 150.0 ppm
	Carbon Dioxide	< 5.0 ppm	< 5.0 ppm
	Ammonia	< 2.0 ppm	< 2.0 ppm
	Ammonia Chloride, Nitrate, Hydroxide, Sulfate	< 0.5 ppm	< 0.5 ppm
Iron Fouling	Total Dissolved Solids (TDS)	< 1,000 ppm	< 1,500 ppm
	Iron, Iron Bacteria	< 0.2 ppm	< 0.2 ppm
	Iron Oxide	< 1.0 ppm	< 1.0 ppm
Erosion	Suspend Solids	< 10.0 ppm, < 600.0 Micron or 30.0 mesh filter size	< 10 ppm, < 600 Micron or 30.0 mesh filter size
	Design Water Velocity	3.0 GPM/TON	3.0 GPM/TON

First Co. / AE-Air reserves the right to change, alter, or update data, design features, and specifications without prior notice.

ELECTRICAL DATA

Table 21: Electrical Data								
Model	Voltage-Ph-Hz	Compressor		Blower Motor			Min. Circuit Ampacity (MCA)	Max. Circuit Protection (MCP)
		RLA	LRA	FLA	HP	kW		
WSV6009	208/230-1-60	4.0	22.0	2.3	1/4	0.18	8.0	15.0
	265-1-60	4.0	23.0	2.3	1/4	0.18	8.0	15.0
WSV6012	208/230-1-60	4.7	25.0	2.3	1/4	0.18	9.0	15.0
	265-1-60	3.9	21.0	2.3	1/4	0.18	8.0	15.0
WSV6018	208/230-1-60	7.2	47.0	2.8	1/3	0.25	12.0	15.0
	265-1-60	5.5	36.0	2.6	1/3	0.25	10.0	15.0
WSV6024	208/230-1-60	11.3	63.0	4.6	1/2	0.37	19.0	30.0
	265-1-60	8.1	45.0	3.6	1/2	0.37	14.0	20.0
	208/230-3-60	7.7	59.9	4.6	1/2	0.37	15.0	20.0
	460-3-60	3.8	32.4	2.1	1/2	0.37	7.0	15.0
WSV6030	208/230-1-60	12.8	71.0	4.6	1/2	0.37	21.0	30.0
	265-1-60	10.4	68.0	3.6	1/2	0.37	17.0	25.0
	208/230-3-60	8.3	67.7	4.6	1/2	0.37	15.0	20.0
	460-3-60	5.1	38.1	2.1	1/2	0.37	9.0	15.0
WSV6036	208/230-1-60	15.5	86.0	4.6	1/2	0.37	24.0	35.0
	265-1-60	10.3	55.0	3.6	1/2	0.37	17.0	25.0
	208/230-3-60	21.8	70.0	4.6	1/2	0.37	32.0	50.0
	460-3-60	7.1	39.0	2.1	1/2	0.37	11.0	15.0
WSV6042	208/230-1-60	17.3	96.0	6.3	3/4	0.56	28.0	45.0
	208/230-3-60	23.2	90.0	6.3	3/4	0.56	36.0	50.0
	460-3-60	6.5	36.0	3.2	3/4	0.56	12.0	15.0
WSV6048	208/230-1-60	19.3	102.0	7.6	1.0	0.75	32.0	50.0
	208/230-3-60	22.1	123.0	7.6	1.0	0.75	36.0	50.0
	460-3-60	10.7	60.0	4.0	1.0	0.75	18.0	25.0
WSV6060	208/230-1-60	26.6	148.0	7.6	1.0	0.75	41.0	60.0
	208/230-3-60	16.7	93.0	7.6	1.0	0.75	29.0	45.0
	460-3-60	6.6	60.0	4.0	1.0	0.75	13.0	15.0
WSV6072	208/230-1-60	30.1	170.0	7.6	1.0	0.75	46.0	70.0
	208/230-3-60	21.2	156.5	7.6	1.0	0.75	35.0	50.0
	460-3-60	9.1	74.8	4.0	1.0	0.75	16.0	20.0

First Co. / AE-Air reserves the right to change, alter, or update data, design features, and specifications without prior notice.

ELECTRICAL DATA (CONTINUED)

HIGH VOLTAGE

WARNING

ELECTRIC SHOCK HAZARD

Disconnect all power supplies before servicing the unit. Lock out and tag out each power source to prevent accidental electrical shock. Note: The unit may be supplied by multiple power sources.

WARNING

Only use copper conductors.

WARNING

Ensure all parts and panels are properly installed before operating the unit. Failure to follow these warnings may result in personal injury or death.

All wiring must comply with local and national code requirements. Units are provided with wiring diagrams and nameplate data to provide information required for necessary field wiring.

The WSV6 water source heat pumps are equipped with a Class 2 transformer for 24 VAC control circuits. If any field-installed accessory or component is also supplied with a Class 2 transformer, care must be taken to prevent interconnection of transformer outputs. Use a thermostat with isolating contacts to avoid backfeeding between transformers.

WARNING

Connect ground wire to ground terminal marked "GND". Failure to do so can result in injury or death.

CAUTION

Any factory-supplied device intended for field installation must be wired exactly as shown in the associated wiring diagram. Failure to comply may result in component damage and void all warranties.

208-240 VOLT OPERATION

All 208–240V units are factory wired for 240V operation. For 208V operation, the line-voltage tap on the 24V control transformer must be moved/rewired accordingly. Refer to Note 3 on the wiring diagram for detailed instructions.

WARNING

ELECTRIC SHOCK HAZARD

Install a disconnect device in the fixed wiring in accordance with applicable wiring regulations. Failure to comply may result in unsafe operation, personal injury, or death.

LOW VOLTAGE THERMOSTAT

A standard 24 VAC heat pump thermostat is required and must be capable of energizing the reversing valve in the cooling mode.

Thermostat connections and functions are shown in **Figure 19 – Thermostat Connections** and are defined as follows:

- C – 24 VAC transformer common
- O – Reversing valve (energized in cooling)
- Y – Compressor contactor
- R – 24 VAC transformer hot
- G – Evaporator Blower
- DH - Dehumidification

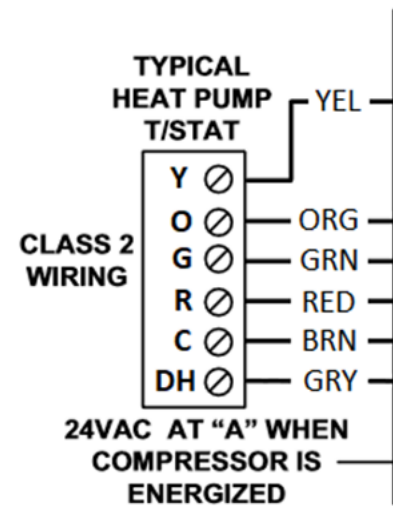

Figure 19 – Thermostat Connections

THERMOSTAT INSTALLATION

The thermostat should be mounted on an interior wall in a larger room, away from supply air drafts. Position the thermostat backplate so it is level and route the thermostat wiring through the center of the backplate mount. Drill mounting holes using a 3/16" [5.0 mm] bit, install the supplied anchors, and secure the backplate to the wall. Thermostat wiring must be 18 AWG.

WARNING

Transformers are multi-voltage. Always refer to the unit wiring diagram and nameplate voltage to ensure correct connections and safe operation.

PERFORMANCE DATA

BLOWER DATA

Table 22: Blower Data																
Model	Fan Speed	Rated Airflow	Blower Data										Factory Settings			
			CFM vs. Static Pressure (in. w.c.)										Cooling		Heating	
			0.1	0.2	0.3	0.4	0.5	0.6	0.7	0.8	0.9	1.0	<10 min	10 + min		
WSV6009	WHT	330	380	360	330	300	270	250							X	X
	VIO		360	330	300	260								X		
	GRY		310	290	270	250										
WSV6012	WHT	430	470	450	430	400	370	340	310						X	X
	VIO		440	410	380	350	320							X		
	GRY		380	360	340	320										
WSV6018	T3	600	730	700	660	630	590	550	520						X	X
	T2		610	580	540	500								X		
	T1		540	510	480	450										
WSV6024	T3	800	900	870	840	810	780	750	720						X	X
	T2		760	740	710	650								X		
	T1		700	670	630	600										
WSV6030	T3	925	1,160	1,130	1,100	1,070	1,040	1,010	980	950	930	900			X	X
	T2		1,040	1,000	980	940	900	870	840	810				X		
	T1		940	910	870	830	800	760								
WSV6036	T3	1,150	1,380	1,350	1,320	1,290	1,270	1,240	1,210	1,180	1,150	1,120			X	X
	T2		1,130	1,090	1,060	1,030	1,000	970						X		
	T1		1,060	1,030	990	960										
WSV6042	T3	1,330	1,420	1,400	1,370	1,340	1,320	1,290	1,260	1,230	1,200	1,170			X	X
	T2		1,330	1,300	1,270	1,240	1,220	1,190	1,160	1,130				X		
	T1		1,190	1,160	1,130	1,100										
WSV6048	T3	1,500	1,660	1,630	1,620	1,580	1,560	1,520	1,490	1,460	1,430	1,400			X	X
	T2		1,550	1,530	1,510	1,480	1,450	1,420	1,390	1,360	1,330	1,300		X		
	T1		1,370	1,350	1,330	1,290	1,260									
WSV6048 ECON	T3	1,500	1,660	1,630	1,620	1,580	1,560	1,520	1,490	1,460	1,430	1,400			X	X
	T2		1,550	1,530	1,510	1,480	1,450	1,420	1,390	1,360	1,330	1,300		X		
	T1		1,370	1,350	1,330	1,290	1,260									
WSV6060	T3	1,875	2,290	2,250	2,210	2,160	2,120	2,070	2,020	1,970	1,910	1,840			X	X
	T2		1,920	1,880	1,840	1,790	1,750	1,700	1,650	1,600	1,540	1,470		X		
	T1		1,820	1,780	1,730	1,690	1,640	1,590	1,550	1,490	1,440	1,370				
WSV6060 ECON	T3	1,875	2,290	2,250	2,210	2,160	2,120	2,070	2,020	1,970	1,910	1,840			X	X
	T2		1,920	1,880	1,840	1,790	1,750	1,700	1,650	1,600	1,540	1,470		X		
	T1		1,820	1,780	1,730	1,690	1,640	1,590	1,550	1,490	1,440	1,370				
WSV6072	T3	1,900	2,290	2,250	2,210	2,160	2,120	2,070	2,020	1,970	1,910	1,840			X	X
	T2		2,140	2,100	2,060	2,010	1,970	1,920	1,870	1,820	1,760	1,690		X		
	T1		1,990	1,950	1,910	1,860	1,820	1,770	1,720	1,670	1,610	1,540				
WSV6072 ECON	T3	1,900	2,290	2,250	2,210	2,160	2,120	2,070	2,020	1,970	1,910	1,840			X	X
	T2		2,140	2,100	2,060	2,010	1,970	1,920	1,870	1,820	1,760	1,690		X		
	T1		1,990	1,950	1,910	1,860	1,820	1,770	1,720	1,670	1,610	1,540				

Notes:

1. Airflow data shown is with a dry coil at 70.0°F [21.1°C] DB EAT and with standard 1.0" [2.5 cm] filter.
2. Operation not recommended in gray shaded areas.

First Co. / AE-Air reserves the right to change, alter, or update data, design features, and specifications without prior notice.

PERFORMANCE DATA (CONTINUED)

PRESSURE & TEMPERATURE DATA

Table 23: WSV6009 Pressure & Temperature Data													
EWT	Water Flow	Cooling				Heating							
		Suction Pres.	Discharge Pres.	Air Temp Drop	Water Temp Rise	Suction Pres.	Discharge Pres.	Air Temp Drop	Water Temp Rise				
°F [°C]	GPM [l/min]	psig [kPa]	psig [kPa]	°F [°C]	°F [°C]	psig [kPa]	psig [kPa]	°F [°C]	°F [°C]				
20 [-6.7]	1.1 [4.2]	Operation Not Recommended				Operation Not Recommended							
	1.7 [6.4]												
	2.3 [8.7]												
30 [-1.1]	1.1 [4.2]					Operation Not Recommended				61-71 [421-490]	258-268 [1,779-1,848]	17-23 [9.4-12.8]	7-11 [3.9-6.1]
	1.7 [6.4]									62-72 [427-496]	262-272 [1,806-1,875]	18-24 [10.0-13.3]	5-9 [2.8-5.0]
	2.3 [8.7]									63-73 [434-503]	264-274 [1,820-1,889]	18-24 [10.0-13.3]	3-7 [1.7-3.9]
50 [10.0]	1.1 [4.2]	128-138 [883-951]	214-224 [1,475-1,544]	22-28 [12.2-15.6]	21-25 [11.7-13.9]					83-93 [572-641]	290-300 [1,999-2,068]	22-28 [12.2-15.6]	9-13 [5.0-7.2]
	1.7 [6.4]	137-147 [945-1,014]	193-203 [1,331-1,400]	22-28 [12.2-15.6]	13-17 [7.2-9.4]					90-100 [621-689]	296-206 [2,041-1,420]	24-30 [13.3-16.7]	6-10 [3.3-5.6]
	2.3 [8.7]	126-136 [869-938]	183-193 [1,262-1,331]	22-28 [12.2-15.6]	10-14 [5.6-7.8]					93-103 [641-710]	299-309 [2,062-2,130]	24-30 [13.3-16.7]	4-8 [2.2-4.4]
70 [21.1]	1.1 [4.2]	132-142 [910-979]	284-294 [1,958-2,027]	21-27 [11.7-15.0]	20-24 [11.1-13.3]	118-128 [814-883]	324-334 [2,234-2,303]	29-35 [16.1-19.4]	13-17 [7.2-9.4]				
	1.7 [6.4]	130-140 [896-965]	260-270 [1,793-1,862]	21-27 [11.7-15.0]	13-17 [7.2-9.4]	120-130 [827-896]	335-345 [2,310-2,379]	30-36 [16.7-20.0]	9-13 [5.0-7.2]				
	2.3 [8.7]	130-140 [896-965]	249-259 [1,717-1,786]	21-27 [11.7-15.0]	9-13 [5.0-7.2]	144-154 [993-1062]	340-350 [2,344-2,413]	32-38 [17.8-21.1]	6-10 [3.3-5.6]				
90 [32.2]	1.1 [4.2]	135-145 [931-1,000]	367-377 [2,530-2,599]	19-25 [10.6-13.9]	19-23 [10.6-12.8]	159-169 [1096-1165]	373-383 [2,572-2,641]	37-43 [20.6-23.9]	17-21 [9.4-11.7]				
	1.7 [6.4]	134-144 [924-993]	342-352 [2,358-2,427]	20-26 [11.1-14.4]	12-16 [6.7-8.9]	175-185 [1,207-1,276]	383-393 [2,641-2,710]	39-45 [21.7-25.0]	12-16 [6.7-8.9]				
	2.3 [8.7]	134-144 [924-993]	330-340 [2,275-2,344]	20-26 [11.1-14.4]	9-13 [5.0-7.2]	184-194 [1,269-1,338]	392-402 [2,703-2,772]	41-47 [22.8-26.1]	9-13 [5.0-7.2]				
110 [43.3]	1.1 [4.2]	142-152 [979-1,048]	468-478 [3,227-3,296]	18-24 [10.0-13.3]	18-22 [10.0-12.2]	Operation Not Recommended							
	1.7 [6.4]	140-150 [965-1,034]	442-452 [3,047-3,116]	18-24 [10.0-13.3]	12-16 [6.7-8.9]								
	2.3 [8.7]	139-149 [958-1,027]	430-440 [2,965-3,034]	19-25 [10.6-13.9]	8-12 [4.4-6.7]								

First Co. / AE-Air reserves the right to change, alter, or update data, design features, and specifications without prior notice.

PERFORMANCE DATA (CONTINUED)

PRESSURE & TEMPERATURE DATA

Table 24: WSV6012 Pressure & Temperature Data									
		Cooling				Heating			
EWT	Water Flow	Suction Pres.	Discharge Pres.	Air Temp Drop	Water Temp Rise	Suction Pres.	Discharge Pres.	Air Temp Drop	Water Temp Rise
°F [°C]	GPM [l/min]	psig [kPa]	psig [kPa]	°F [°C]	°F [°C]	psig [kPa]	psig [kPa]	°F [°C]	°F [°C]
20 [-6.7]	1.5 [5.7]	Operation Not Recommended				Operation Not Recommended			
	2.3 [8.7]								
	3.0 [11.4]								
30 [-1.1]	1.5 [5.7]	Operation Not Recommended				59-69 [407-476]	263-273 [1,813-1,882]	16-22 [8.9-12.2]	7-11 [3.9-6.1]
	2.3 [8.7]					64-57 [441-393]	268-278 [1,848-1,917]	17-23 [9.4-12.8]	4-8 [2.2-4.4]
	3.0 [11.4]					68-78 [469-538]	270-280 [1,862-1,931]	18-24 [10.0-13.3]	3-7 [1.7-3.9]
50 [10.0]	1.5 [5.7]	126-136 [869-938]	215-225 [1,482-1,551]	20-26 [11.1-14.4]	21-25 [11.7-13.9]	85-95 [586-655]	296-306 [2,041-2,110]	22-28 [12.2-15.6]	9-13 [5.0-7.2]
	2.3 [8.7]	125-135 [862-931]	194-204 [1,338-1,407]	21-27 [11.7-15.0]	13-17 [7.2-9.4]	92-102 [634-703]	303-313 [2,089-2,158]	23-29 [12.8-16.1]	6-10 [3.3-5.6]
	3.0 [11.4]	124-134 [855-924]	183-193 [1,262-1,331]	21-27 [11.7-15.0]	9-13 [5.0-7.2]	95-105 [655-724]	306-316 [2,110-2,179]	24-30 [13.3-16.7]	4-8 [2.2-4.4]
70 [21.1]	1.5 [5.7]	130-140 [896-965]	284-294 [1,958-2,027]	19-25 [10.6-13.9]	20-24 [11.1-13.3]	121-131 [834-903]	334-344 [2,303-2,372]	29-35 [16.1-19.4]	13-17 [7.2-9.4]
	2.3 [8.7]	128-138 [883-951]	260-270 [1,793-1,862]	20-26 [11.1-14.4]	13-17 [7.2-9.4]	131-141 [903-972]	345-355 [2,379-2,448]	31-37 [17.2-20.6]	8-12 [4.4-6.7]
	3.0 [11.4]	128-138 [883-951]	248-258 [1,710-1,779]	20-26 [11.1-14.4]	9-13 [5.0-7.2]	137-147 [945-1,014]	358-368 [2,468-2,537]	32-38 [17.8-21.1]	6-10 [3.3-5.6]
90 [32.2]	1.5 [5.7]	134-144 [924-993]	366-376 [2,523-2,592]	18-24 [10.0-13.3]	20-24 [11.1-13.3]	163-173 [1,124-1,193]	383-393 [2,641-2,710]	37-43 [20.6-23.9]	16-20 [8.9-11.1]
	2.3 [8.7]	133-143 [917-986]	341-351 [2,351-2,420]	19-25 [10.6-13.9]	13-17 [7.2-9.4]	179-189 [1,234-1,303]	401-411 [2,765-2,834]	40-46 [22.2-25.6]	11-15 [6.1-8.3]
	3.0 [11.4]	132-142 [910-979]	328-338 [2,261-2,330]	19-25 [10.6-13.9]	9-13 [5.0-7.2]	188-198 [1,296-1,365]	412-422 [2,841-2,910]	42-48 [23.3-26.7]	8-12 [4.4-6.7]
110 [43.3]	1.5 [5.7]	139-149 [958-1027]	466-476 [3,213-3,282]	17-23 [9.4-12.8]	19-23 [10.6-12.8]	Operation Not Recommended			
	2.3 [8.7]	138-148 [951-1,020]	439-449 [3,027-3,096]	17-23 [9.4-12.8]	12-16 [6.7-8.9]				
	3.0 [11.4]	137-147 [945-1,014]	426-436 [2,937-3,006]	17-23 [9.4-12.8]	9-13 [5.0-7.2]				

First Co. / AE-Air reserves the right to change, alter, or update data, design features, and specifications without prior notice.

PERFORMANCE DATA (CONTINUED)

PRESSURE & TEMPERATURE DATA

Table 25: WSV6018 Pressure & Temperature Data									
EWT	Water Flow	Cooling				Heating			
		Suction Pres.	Discharge Pres.	Air Temp Drop	Water Temp Rise	Suction Pres.	Discharge Pres.	Air Temp Drop	Water Temp Rise
°F [°C]	GPM [l/min]	psig [kPa]	psig [kPa]	°F [°C]	°F [°C]	psig [kPa]	psig [kPa]	°F [°C]	°F [°C]
20 [-6.7]	2.3 [8.7]	Operation Not Recommended				Operation Not Recommended			
	3.4 [12.9]								
	4.5 [17.0]								
30 [-1.1]	2.3 [8.7]	Operation Not Recommended				62-72 [427-496]	276-286 [1,903-1,972]	16-22 [8.9-12.2]	7-11 [3.9-6.1]
	3.4 [12.9]					65-75 [448-517]	282-292 [1,944-2,013]	17-23 [9.4-12.8]	5-9 [2.8-5.0]
	4.5 [17.0]					70-80 [483-552]	283-293 [1,951-2,020]	18-24 [10.0-13.3]	3-7 [1.7-3.9]
50 [10.0]	2.3 [8.7]	124-134 [855-924]	212-222 [1,462-1,531]	19-25 [10.6-13.9]	17-21 [9.4-11.7]	95-105 [655-724]	334-344 [2,303-2,372]	24-30 [13.3-16.7]	9-13 [5.0-7.2]
	3.4 [12.9]	123-133 [848-917]	194-204 [1,338-1,407]	20-26 [11.1-14.4]	11-15 [6.1-8.3]	103-113 [710-779]	344-354 [2,372-2,441]	26-32 [14.4-17.8]	6-10 [3.3-5.6]
	4.5 [17.0]	122-132 [841-910]	186-196 [1,282-1,351]	20-26 [11.1-14.4]	8-12 [4.4-6.7]	107-117 [738-807]	360-360 [2,482-2,482]	27-33 [15.0-18.3]	4-8 [2.2-4.4]
70 [21.1]	2.3 [8.7]	128-138 [883-951]	282-292 [1,944-2,013]	18-24 [10.0-13.3]	17-21 [9.4-11.7]	132-142 [910-979]	383-393 [2,641-2,710]	31-37 [17.2-20.6]	12-16 [6.7-8.9]
	3.4 [12.9]	127-137 [876-945]	262-272 [1,806-1,875]	19-25 [10.6-13.9]	10-14 [5.6-7.8]	143-153 [986-1,055]	399-409 [2,751-2,820]	33-39 [18.3-21.7]	8-12 [4.4-6.7]
	4.5 [17.0]	126-136 [869-938]	253-263 [1,744-1,813]	19-25 [10.6-13.9]	7-11 [3.9-6.1]	150-160 [1,034-1,103]	408-418 [2,813-2,882]	35-41 [19.4-22.8]	6-10 [3.3-5.6]
90 [32.2]	2.3 [8.7]	132-142 [910-979]	367-377 [2,530-2,599]	18-24 [10.0-13.3]	16-20 [8.9-11.1]	178-188 [1,227-1,296]	444-454 [3,061-3,130]	39-45 [21.7-25.0]	16-20 [8.9-11.1]
	3.4 [12.9]	131-141 [903-972]	346-356 [2,386-2,455]	18-24 [10.0-13.3]	10-14 [5.6-7.8]	195-205 [1,344-1,413]	466-476 [3,213-3,282]	42-48 [23.3-26.7]	10-14 [5.6-7.8]
	4.5 [17.0]	131-141 [903-972]	338-348 [2,330-2,399]	18-24 [10.0-13.3]	7-11 [3.9-6.1]	205-215 [1,413-1,482]	479-489 [3,303-3,372]	43-49 [23.9-27.2]	8-12 [4.4-6.7]
110 [43.3]	2.3 [8.7]	137-147 [945-1,014]	471-481 [3,247-3,316]	16-22 [8.9-12.2]	16-20 [8.9-11.1]	Operation Not Recommended			
	3.4 [12.9]	136-146 [938-1,007]	449-459 [3,096-3,165]	17-23 [9.4-12.8]	10-14 [5.6-7.8]				
	4.5 [17.0]	136-146 [938-1,007]	442-452 [3,047-3,116]	17-23 [9.4-12.8]	7-11 [3.9-6.1]				

First Co. / AE-Air reserves the right to change, alter, or update data, design features, and specifications without prior notice.

PERFORMANCE DATA (CONTINUED)

PRESSURE & TEMPERATURE DATA

Table 26: WSV6024 Pressure & Temperature Data									
EWT	Water Flow	Cooling				Heating			
		Suction Pres.	Discharge Pres.	Air Temp Drop	Water Temp Rise	Suction Pres.	Discharge Pres.	Air Temp Drop	Water Temp Rise
°F [°C]	GPM [l/min]	psig [kPa]	psig [kPa]	°F [°C]	°F [°C]	psig [kPa]	psig [kPa]	°F [°C]	°F [°C]
20 [-6.7]	3.0 [11.4]	Operation Not Recommended				Operation Not Recommended			
	4.5 [17.0]								
	6.0 [22.7]								
30 [-1.1]	3.0 [11.4]	Operation Not Recommended				56-66 [386-455]	253-263 [1,744-1,813]	16-22 [8.9-12.2]	7-11 [3.9-6.1]
	4.5 [17.0]					61-71 [421-490]	256-266 [1,765-1,834]	17-23 [9.4-12.8]	4-8 [2.2-4.4]
	6.0 [22.7]					66-76 [455-524]	259-269 [1,786-1,855]	18-24 [10.0-13.3]	3-7 [1.7-3.9]
50 [10.0]	3.0 [11.4]	126-136 [869-938]	202-212 [1,393-1,462]	20-26 [11.1-14.4]	20-24 [11.1-13.3]	93-103 [641-710]	294-204 [2,027-1,407]	19-25 [10.6-13.9]	9-13 [5.0-7.2]
	4.5 [17.0]	125-135 [862-931]	187-197 [1,289-1,358]	20-26 [11.1-14.4]	13-17 [7.2-9.4]	98-108 [676-745]	300-310 [2,068-2,137]	20-26 [11.1-14.4]	6-10 [3.3-5.6]
	6.0 [22.7]	113-123 [779-848]	180-190 [1,241-1,310]	20-26 [11.1-14.4]	9-13 [5.0-7.2]	102-112 [703-772]	303-313 [2,089-2,158]	21-27 [11.7-15.0]	4-8 [2.2-4.4]
70 [21.1]	3.0 [11.4]	130-140 [896-965]	271-281 [1,868-1,937]	19-25 [10.6-13.9]	20-24 [11.1-13.3]	130-140 [896-965]	330-340 [2,275-2,344]	26-32 [14.4-17.8]	12-16 [6.7-8.9]
	4.5 [17.0]	129-139 [889-958]	255-265 [1,758-1,827]	19-25 [10.6-13.9]	13-17 [7.2-9.4]	140-150 [965-1,034]	339-349 [2,337-2,406]	27-33 [15.0-18.3]	8-12 [4.4-6.7]
	6.0 [22.7]	129-139 [889-958]	247-257 [1,703-1,772]	19-25 [10.6-13.9]	9-13 [5.0-7.2]	145-155 [1,000-1,069]	344-354 [2,372-2,441]	28-34 [15.6-18.9]	6-10 [3.3-5.6]
90 [32.2]	3.0 [11.4]	135-145 [931-1,000]	357-367 [2,461-2,530]	18-24 [10.0-13.3]	19-23 [10.6-12.8]	176-186 [1,213-1,282]	385-395 [2,654-2,723]	33-39 [18.3-21.7]	16-20 [8.9-11.1]
	4.5 [17.0]	134-144 [924-993]	340-350 [2,344-2,413]	18-24 [10.0-13.3]	12-16 [6.7-8.9]	191-201 [1,317-1,386]	388-398 [2,675-2,744]	35-41 [19.4-22.8]	11-15 [6.1-8.3]
	6.0 [22.7]	133-143 [917-986]	331-341 [2,282-2,351]	18-24 [10.0-13.3]	9-13 [5.0-7.2]	199-209 [1,372-1,441]	407-417 [2,806-2,875]	37-43 [20.6-23.9]	8-12 [4.4-6.7]
110 [43.3]	3.0 [11.4]	140-150 [965-1,034]	461-471 [3,178-3,247]	17-23 [9.4-12.8]	18-22 [10.0-12.2]	Operation Not Recommended			
	4.5 [17.0]	139-149 [958-1,027]	443-453 [3,054-3,123]	17-23 [9.4-12.8]	12-16 [6.7-8.9]				
	6.0 [22.7]	139-149 [958-1,027]	434-444 [2,992-3,061]	17-23 [9.4-12.8]	8-12 [4.4-6.7]				

First Co. / AE-Air reserves the right to change, alter, or update data, design features, and specifications without prior notice.

PERFORMANCE DATA (CONTINUED)

PRESSURE & TEMPERATURE DATA

Table 27: WSV6036 Pressure & Temperature Data									
EWT	Water Flow	Cooling				Heating			
		Suction Pres.	Discharge Pres.	Air Temp Drop	Water Temp Rise	Suction Pres.	Discharge Pres.	Air Temp Drop	Water Temp Rise
°F [°C]	GPM [l/min]	psig [kPa]	psig [kPa]	°F [°C]	°F [°C]	psig [kPa]	psig [kPa]	°F [°C]	°F [°C]
20 [-6.7]	4.5 [17.0]	Operation Not Recommended				Operation Not Recommended			
	6.8 [25.7]								
	9.0 [34.1]								
30 [-1.1]	4.5 [17.0]	Operation Not Recommended				62-72 [427-496]	265-275 [1,827-1,896]	19-25 [10.6-13.9]	7-11 [3.9-6.1]
	6.8 [25.7]					66-76 [455-524]	269-279 [1,855-1,924]	20-26 [11.1-14.4]	4-8 [2.2-4.4]
	9.0 [34.1]					70-80 [483-552]	275-285 [1,896-1,965]	21-27 [11.7-15.0]	2-6 [1.1-3.3]
50 [10.0]	4.5 [17.0]	122-132 [841-910]	221-231 [1,524-1,593]	23-29 [12.8-16.1]	19-23 [10.6-12.8]	93-103 [641-710]	311-321 [2,144-2,213]	25-31 [13.9-17.2]	9-13 [5.0-7.2]
	6.8 [25.7]	120-130 [827-896]	203-213 [1,400-1,469]	23-29 [12.8-16.1]	12-16 [6.7-8.9]	100-110 [689-758]	319-329 [2,199-2,268]	26-32 [14.4-17.8]	6-10 [3.3-5.6]
	9.0 [34.1]	120-130 [827-896]	194-204 [1,338-1,407]	23-29 [12.8-16.1]	9-13 [5.0-7.2]	104-114 [717-786]	323-333 [2,227-2,296]	27-33 [15.0-18.3]	4-8 [2.2-4.4]
70 [21.1]	4.5 [17.0]	126-136 [869-938]	294-304 [2,027-2,096]	22-28 [12.2-15.6]	19-23 [10.6-12.8]	130-140 [896-965]	353-363 [2,434-2,503]	32-38 [17.8-21.1]	13-17 [7.2-9.4]
	6.8 [25.7]	125-135 [862-931]	273-283 [1,882-1,951]	22-28 [12.2-15.6]	12-16 [6.7-8.9]	141-151 [972-1,041]	365-375 [2,517-2,586]	34-40 [18.9-22.2]	8-12 [4.4-6.7]
	9.0 [34.1]	124-134 [855-924]	264-274 [1,820-1,889]	22-28 [12.2-15.6]	9-13 [5.0-7.2]	148-158 [1,020-1,089]	373-383 [2,572-2,641]	36-42 [20.0-23.3]	6-10 [3.3-5.6]
90 [32.2]	4.5 [17.0]	131-141 [903-972]	382-392 [2,634-2,703]	21-27 [11.7-15.0]	18-22 [10.0-12.2]	175-185 [1,207-1,276]	403-413 [2,779-2,848]	41-47 [22.8-26.1]	16-20 [8.9-11.1]
	6.8 [25.7]	129-139 [889-958]	360-370 [2,482-2,551]	21-27 [11.7-15.0]	12-16 [6.7-8.9]	192-202 [1,324-1,393]	421-431 [2,903-2,972]	43-49 [23.9-27.2]	11-15 [6.1-8.3]
	9.0 [34.1]	129-139 [889-958]	350-360 [2,413-2,482]	21-27 [11.7-15.0]	8-12 [4.4-6.7]	202-212 [1,393-1,462]	432-442 [2,979-3,047]	45-61 [25.0-33.9]	8-12 [4.4-6.7]
110 [43.3]	4.5 [17.0]	136-146 [938-1,007]	489-499 [3,372-3,440]	19-25 [10.6-13.9]	18-22 [10.0-12.2]	Operation Not Recommended			
	6.8 [25.7]	135-145 [931-1,000]	466-476 [3,213-3,282]	20-26 [11.1-14.4]	11-15 [6.1-8.3]				
	9.0 [34.1]	135-145 [931-1,000]	457-467 [3,151-3,220]	20-26 [11.1-14.4]	8-12 [4.4-6.7]				

First Co. / AE-Air reserves the right to change, alter, or update data, design features, and specifications without prior notice.

PERFORMANCE DATA (CONTINUED)

PRESSURE & TEMPERATURE DATA

Table 28: WSV6042 Pressure & Temperature Data													
		Cooling				Heating							
EWT	Water Flow	Suction Pres.	Discharge Pres.	Air Temp Drop	Water Temp Rise	Suction Pres.	Discharge Pres.	Air Temp Drop	Water Temp Rise				
°F [°C]	GPM [l/min]	psig [kPa]	psig [kPa]	°F [°C]	°F [°C]	psig [kPa]	psig [kPa]	°F [°C]	°F [°C]				
20 [-6.7]	5.3 [20.1]	Operation Not Recommended				Operation Not Recommended							
	7.9 [29.9]												
	10.5 [39.8]												
30 [-1.1]	5.3 [20.1]									58-68 [400-469]	262-272 [1,806-1,875]	19-25 [10.6-13.9]	5-9 [2.8-5.0]
	7.9 [29.9]									62-72 [427-496]	266-276 [1,834-1,903]	20-26 [11.1-14.4]	3-7 [1.7-3.9]
	10.5 [39.8]									64-74 [441-510]	271-281 [1,868-1,937]	21-27 [11.7-15.0]	2-6 [1.1-3.3]
50 [10.0]	5.3 [20.1]	128-138 [883-951]	226-236 [1,558-1,627]	24-30 [13.3-16.7]	20-24 [11.1-13.3]	89-99 [614-683]	293-303 [2,020-2,089]	24-30 [13.3-16.7]	8-12 [4.4-6.7]				
	7.9 [29.9]	127-137 [876-945]	205-215 [1,413-1,482]	25-31 [13.9-17.2]	13-17 [7.2-9.4]	95-105 [655-724]	299-309 [2,062-2,130]	25-31 [13.9-17.2]	5-9 [2.8-5.0]				
	10.5 [39.8]	126-136 [869-938]	195-205 [1,344-1,413]	25-31 [13.9-17.2]	9-13 [5.0-7.2]	99-109 [683-752]	302-312 [2,082-2,151]	26-32 [14.4-17.8]	3-7 [1.7-3.9]				
70 [21.1]	5.3 [20.1]	133-143 [917-986]	298-308 [2,055-2,124]	23-29 [12.8-16.1]	19-23 [10.6-12.8]	126-136 [869-938]	328-338 [2,261-2,330]	31-37 [17.2-20.6]	11-15 [6.1-8.3]				
	7.9 [29.9]	131-141 [903-972]	274-284 [1,889-1,958]	24-30 [13.3-16.7]	12-16 [6.7-8.9]	134-144 [924-993]	336-346 [2,317-2,386]	33-39 [18.3-21.7]	8-12 [4.4-6.7]				
	10.5 [39.8]	131-141 [903-972]	263-273 [1,813-1,882]	24-30 [13.3-16.7]	9-13 [5.0-7.2]	141-151 [972-1,041]	343-353 [2,365-2,434]	34-40 [18.9-22.2]	5-9 [2.8-5.0]				
90 [32.2]	5.3 [20.1]	137-147 [945-1,014]	385-395 [2,654-2,723]	22-28 [12.2-15.6]	18-22 [10.0-12.2]	170-180 [1,172-1,241]	372-382 [2,565-2,634]	39-45 [21.7-25.0]	15-19 [8.3-10.6]				
	7.9 [29.9]	136-146 [938-1,007]	359-369 [2,475-2,544]	22-28 [12.2-15.6]	12-16 [6.7-8.9]	185-195 [1,276-1,344]	387-397 [2,668-2,737]	42-48 [23.3-26.7]	10-14 [5.6-7.8]				
	10.5 [39.8]	135-145 [931-1,000]	348-358 [2,399-2,468]	23-29 [12.8-16.1]	8-12 [4.4-6.7]	194-204 [1,338-1,407]	395-405 [2,723-2,792]	43-50 [23.9-27.8]	7-11 [3.9-6.1]				
110 [43.3]	5.3 [20.1]	143-153 [986-1,055]	489-499 [3,372-3,440]	21-27 [11.7-15.0]	18-22 [10.0-12.2]	Operation Not Recommended							
	7.9 [29.9]	141-151 [972-1,041]	463-473 [3,192-3,261]	21-27 [11.7-15.0]	11-15 [6.1-8.3]								
	10.5 [39.8]	141-151 [972-1,041]	451-461 [3,110-3,178]	21-27 [11.7-15.0]	8-12 [4.4-6.7]								

First Co. / AE-Air reserves the right to change, alter, or update data, design features, and specifications without prior notice.

PERFORMANCE DATA (CONTINUED)

PRESSURE & TEMPERATURE DATA

Table 29: WSV6048 Pressure & Temperature Data													
		Cooling				Heating							
EWT	Water Flow	Suction Pres.	Discharge Pres.	Air Temp Drop	Water Temp Rise	Suction Pres.	Discharge Pres.	Air Temp Drop	Water Temp Rise				
°F [°C]	GPM [l/min]	psig [kPa]	psig [kPa]	°F [°C]	°F [°C]	psig [kPa]	psig [kPa]	°F [°C]	°F [°C]				
20 [-6.7]	6.0 [22.7]	Operation Not Recommended				Operation Not Recommended							
	9.0 [34.1]												
	12.0 [45.4]												
30 [-1.1]	6.0 [22.7]					Operation Not Recommended				65-75 [448-517]	271-281 [1,868-1,937]	19-25 [10.6-13.9]	7-11 [3.9-6.1]
	9.0 [34.1]									69-79 [476-545]	275-285 [1,896-1,965]	20-26 [11.1-14.4]	4-8 [2.2-4.4]
	12.0 [45.4]									73-83 [503-572]	280-290 [1,931-1,999]	21-27 [11.7-15.0]	3-7 [1.7-3.9]
50 [10.0]	6.0 [22.7]	122-132 [841-910]	222-232 [1,531-1,600]	24-30 [13.3-16.7]	20-24 [11.1-13.3]					104-114 [717-786]	310-320 [2,137-2,206]	25-31 [13.9-17.2]	9-13 [5.0-7.2]
	9.0 [34.1]	120-130 [827-896]	201-211 [1,386-1,455]	25-31 [13.9-17.2]	13-17 [7.2-9.4]					111-121 [765-834]	316-326 [2,179-2,248]	26-32 [14.4-17.8]	5-9 [2.8-5.0]
	12.0 [45.4]	120-130 [827-896]	191-201 [1,317-1,386]	25-31 [13.9-17.2]	9-13 [5.0-7.2]					115-125 [793-862]	320-330 [2,206-2,275]	27-33 [15.0-18.3]	4-8 [2.2-4.4]
70 [21.1]	6.0 [22.7]	127-137 [876-945]	293-303 [2,020-2,089]	23-29 [12.8-16.1]	20-24 [11.1-13.3]	144-154 [993-1,062]	348-358 [2,399-2,468]	32-38 [17.8-21.1]	12-16 [6.7-8.9]				
	9.0 [34.1]	125-135 [862-931]	269-279 [1,855-1,924]	23-29 [12.8-16.1]	13-17 [7.2-9.4]	155-165 [1,069-1,138]	359-369 [2,475-2,544]	34-40 [18.9-22.2]	8-12 [4.4-6.7]				
	12.0 [45.4]	124-134 [855-924]	257-267 [1,772-1,841]	24-30 [13.3-16.7]	9-13 [5.0-7.2]	161-171 [1,110-1,179]	365-375 [2,517-2,586]	35-41 [19.4-22.8]	5-9 [2.8-5.0]				
90 [32.2]	6.0 [22.7]	132-142 [910-979]	380-390 [2,620-2,689]	22-28 [12.2-15.6]	19-23 [10.6-12.8]	193-203 [1,331-1,400]	395-405 [2,723-2,792]	40-46 [22.2-25.6]	15-19 [8.3-10.6]				
	9.0 [34.1]	130-140 [896-965]	354-364 [2,441-2,510]	22-28 [12.2-15.6]	12-16 [6.7-8.9]	209-219 [1,441-1,510]	411-421 [2,834-2,903]	42-48 [23.3-26.7]	10-14 [5.6-7.8]				
	12.0 [45.4]	129-139 [889-958]	341-351 [2,351-2,420]	22-28 [12.2-15.6]	9-13 [5.0-7.2]	217-227 [1,496-1,565]	420-430 [2,896-2,965]	43-50 [23.9-27.8]	7-11 [3.9-6.1]				
110 [43.3]	6.0 [22.7]	138-148 [951-1,020]	485-495 [3,344-3,413]	21-27 [11.7-15.0]	18-22 [10.0-12.2]	Operation Not Recommended							
	9.0 [34.1]	136-146 [938-1,007]	457-467 [3,151-3,220]	21-27 [11.7-15.0]	12-16 [6.7-8.9]								
	12.0 [45.4]	135-145 [931-1,000]	444-454 [3,061-3,130]	21-27 [11.7-15.0]	8-12 [4.4-6.7]								

First Co. / AE-Air reserves the right to change, alter, or update data, design features, and specifications without prior notice.

PERFORMANCE DATA (CONTINUED)

PRESSURE & TEMPERATURE DATA

Table 30: WSV6060 Pressure & Temperature Data									
		Cooling				Heating			
EWT	Water Flow	Suction Pres.	Discharge Pres.	Air Temp Drop	Water Temp Rise	Suction Pres.	Discharge Pres.	Air Temp Drop	Water Temp Rise
°F [°C]	GPM [l/min]	psig [kPa]	psig [kPa]	°F [°C]	°F [°C]	psig [kPa]	psig [kPa]	°F [°C]	°F [°C]
20 [-6.7]	7.5 [28.4]	Operation Not Recommended				Operation Not Recommended			
	11.3 [42.8]								
	15 [56.8]								
30 [-1.1]	7.5 [28.4]					58-68 [400-469]	265-275 [1,827-1,896]	25-31 [13.9-17.2]	7-11 [3.9-6.1]
	11.3 [42.8]					62-72 [427-496]	269-279 [1,855-1,924]	26-32 [14.4-17.8]	4-8 [2.2-4.4]
	15 [56.8]					64-74 [441-510]	274-284 [1,889-1,958]	27-33 [15.0-18.3]	3-7 [1.7-3.9]
50 [10.0]	7.5 [28.4]	125-135 [862-931]	220-230 [1,517-1,586]	25-31 [13.9-17.2]	19-23 [10.6-12.8]	91-101 [627-696]	309-319 [2,130-2,199]	28-34 [15.6-18.9]	9-13 [5.0-7.2]
	11.3 [42.8]	123-133 [848-917]	201-211 [1,386-1,455]	25-31 [13.9-17.2]	12-16 [6.7-8.9]	98-108 [676-745]	316-326 [2,179-2,248]	29-35 [16.1-19.4]	5-9 [2.8-5.0]
	15 [56.8]	123-133 [848-917]	191-201 [1,317-1,386]	25-31 [13.9-17.2]	9-13 [5.0-7.2]	101-111 [696-765]	320-330 [2,206-2,275]	30-36 [16.7-20.0]	4-8 [2.2-4.4]
70 [21.1]	7.5 [28.4]	129-139 [889-958]	290-300 [1,999-2,068]	24-30 [13.3-16.7]	18-22 [10.0-12.2]	128-138 [883-951]	349-359 [2,406-2,475]	36-42 [20.0-23.3]	12-16 [6.7-8.9]
	11.3 [42.8]	128-138 [883-951]	268-278 [1,848-1,917]	24-30 [13.3-16.7]	12-16 [6.7-8.9]	138-148 [951-1,020]	361-371 [2,489-2,558]	38-44 [21.1-24.4]	8-12 [4.4-6.7]
	15 [56.8]	127-137 [876-945]	257-267 [1,772-1,841]	24-30 [13.3-16.7]	8-12 [4.4-6.7]	144-154 [993-1,062]	367-377 [2,530-2,599]	39-45 [21.7-25.0]	5-9 [2.8-5.0]
90 [32.2]	7.5 [28.4]	134-144 [924-993]	377-387 [2,599-2,668]	23-29 [12.8-16.1]	18-22 [10.0-12.2]	172-182 [1,186-1,255]	398-408 [2,744-2,813]	45-51 [25.0-28.3]	15-19 [8.3-10.6]
	11.3 [42.8]	133-143 [917-986]	352-362 [2,427-2,496]	23-29 [12.8-16.1]	11-15 [6.1-8.3]	187-197 [1,289-1,358]	415-425 [2,861-2,930]	48-54 [26.7-30.0]	10-14 [5.6-7.8]
	15 [56.8]	132-142 [910-979]	340-350 [2,344-2,413]	23-29 [12.8-16.1]	8-12 [4.4-6.7]	196-206 [1,351-1,420]	424-434 [2,923-2,992]	50-56 [27.8-31.1]	7-11 [3.9-6.1]
110 [43.3]	7.5 [28.4]	140-150 [965-1,034]	480-490 [3,309-3,378]	21-27 [11.7-15.0]	17-21 [9.4-11.7]	Operation Not Recommended			
	11.3 [42.8]	139-149 [958-1,027]	455-465 [3,137-3,206]	21-27 [11.7-15.0]	11-15 [6.1-8.3]				
	15 [56.8]	138-148 [951-1,020]	443-453 [3,054-3,123]	22-28 [12.2-15.6]	8-12 [4.4-6.7]				

First Co. / AE-Air reserves the right to change, alter, or update data, design features, and specifications without prior notice.

PERFORMANCE DATA (CONTINUED)

PRESSURE & TEMPERATURE DATA

Table 31: WSV6072 Pressure & Temperature Data									
		Cooling				Heating			
EWT	Water Flow	Suction Pres.	Discharge Pres.	Air Temp Drop	Water Temp Rise	Suction Pres.	Discharge Pres.	Air Temp Drop	Water Temp Rise
°F [°C]	GPM [l/min]	psig [kPa]	psig [kPa]	°F [°C]	°F [°C]	psig [kPa]	psig [kPa]	°F [°C]	°F [°C]
20 [-6.7]	9.0 [34.1]	Operation Not Recommended				Operation Not Recommended			
	13.5 [51.1]								
	18 [68.1]								
30 [-1.1]	9.0 [34.1]					56-66 [386-455]	275-285 [1,896-1,965]	20-26 [11.1-14.4]	5-9 [2.8-5.0]
	13.5 [51.1]					59-69 [407-476]	281-291 [1,937-2,006]	22-28 [12.2-15.6]	3-7 [1.7-3.9]
	18 [68.1]					64-74 [441-510]	283-293 [1,951-2,020]	23-29 [12.8-16.1]	2-6 [1.1-3.3]
50 [10.0]	9.0 [34.1]	122-132 [841-910]	219-229 [1,510-1,579]	25-31 [13.9-17.2]	18-22 [10.0-12.2]	85-95 [586-655]	309-319 [2,130-2,199]	28-34 [15.6-18.9]	8-12 [4.4-6.7]
	13.5 [51.1]	121-131 [834-903]	202-212 [1,393-1,462]	26-32 [14.4-17.8]	12-16 [6.7-8.9]	91-101 [627-696]	316-326 [2,179-2,248]	29-35 [16.1-19.4]	5-9 [2.8-5.0]
	18 [68.1]	120-130 [827-896]	193-203 [1,331-1,400]	26-32 [14.4-17.8]	8-12 [4.4-6.7]	95-105 [655-724]	320-330 [2,206-2,275]	30-36 [16.7-20.0]	3-7 [1.7-3.9]
70 [21.1]	9.0 [34.1]	126-136 [869-938]	288-298 [1,986-2,055]	24-30 [13.3-16.7]	18-22 [10.0-12.2]	119-129 [820-889]	351-361 [2,420-2,489]	36-42 [20.0-23.3]	11-15 [6.1-8.3]
	13.5 [51.1]	125-135 [862-931]	268-278 [1,848-1,917]	24-30 [13.3-16.7]	11-15 [6.1-8.3]	129-139 [889-958]	363-373 [2,503-2,572]	38-44 [21.1-24.4]	7-11 [3.9-6.1]
	18 [68.1]	125-135 [862-931]	259-269 [1,786-1,855]	25-31 [13.9-17.2]	8-12 [4.4-6.7]	135-145 [931-1,000]	370-380 [2,551-2,620]	40-46 [22.2-25.6]	5-9 [2.8-5.0]
90 [32.2]	9.0 [34.1]	132-142 [910-979]	373-383 [2,572-2,641]	23-29 [12.8-16.1]	17-21 [9.4-11.7]	160-170 [1,103-1,172]	403-413 [2,779-2,848]	46-52 [25.6-28.9]	14-18 [7.8-10.0]
	13.5 [51.1]	130-140 [896-965]	351-361 [2,420-2,489]	23-29 [12.8-16.1]	11-15 [6.1-8.3]	175-185 [1,207-1,276]	422-432 [2,910-2,979]	49-55 [27.2-30.6]	10-14 [5.6-7.8]
	18 [68.1]	130-140 [896-965]	341-351 [2,351-2,420]	23-29 [12.8-16.1]	8-12 [4.4-6.7]	184-194 [1,269-1,338]	433-443 [2,985-3,054]	51-57 [28.3-31.7]	7-11 [3.9-6.1]
110 [43.3]	9.0 [34.1]	137-147 [945-1,014]	474-484 [3,268-3,337]	21-27 [11.7-15.0]	17-21 [9.4-11.7]	Operation Not Recommended			
	13.5 [51.1]	136-146 [938-1,007]	451-461 [3,110-3,178]	22-28 [12.2-15.6]	11-15 [6.1-8.3]				
	18 [68.1]	135-145 [931-1,000]	441-451 [3,041-3,110]	22-28 [12.2-15.6]	8-12 [4.4-6.7]				

First Co. / AE-Air reserves the right to change, alter, or update data, design features, and specifications without prior notice.

PERFORMANCE DATA (CONTINUED)

WATER PRESSURE DROP DATA

Table 32: Pressure Drop Data										
WSV6009	Flow Rate GPM [l/min]	1.0 [3.8]	2.0 [7.6]	3.0 [11.4]	4.0 [15.1]	5.0 [18.9]	6.0 [22.7]	7.0 [26.5]		
	Pressure Drop (psi)	0.2	0.9	1.9	3.0	4.5	6.3	8.2		
WSV6012	Flow Rate GPM [l/min]	2.0 [7.6]	3.0 [11.4]	4.0 [15.1]	5.0 [18.9]	6.0 [22.7]	7.0 [26.5]	8.0 [30.3]		
	Pressure Drop (psi)	1.0	2.0	3.3	4.8	6.6	8.7	10.9		
WSV6018	Flow Rate GPM [l/min]	2.0 [7.6]	3.0 [11.4]	4.0 [15.1]	5.0 [18.9]	6.0 [22.7]	7.0 [26.5]	8.0 [30.3]		
	Pressure Drop (psi)	1.0	2.0	3.3	4.8	6.6	8.7	10.9		
WSV6024	Flow Rate GPM [l/min]	5.0 [18.9]	6.0 [22.7]	7.0 [26.5]	8.0 [30.3]	9.0 [34.1]	10.0 [37.9]	10.0 [37.9]		
	Pressure Drop (psi)	1.4	2.0	2.6	3.3	4.1	5.0	6.0		
WSV6030	Flow Rate GPM [l/min]	6.0 [22.7]	7.0 [26.5]	8.0 [30.3]	9.0 [34.1]	10.0 [37.9]	11.0 [41.6]	12.0 [45.4]		
	Pressure Drop (psi)	2.3	3.0	3.9	4.8	5.8	6.9	8.0		
WSV6036	Flow Rate GPM [l/min]	6.0 [22.7]	8.0 [30.3]	10.0 [37.9]	12.0 [45.4]	14.0 [53.0]	16.0 [60.6]	18.0 [68.1]		
	Pressure Drop (psi)	1.1	1.9	2.8	4.0	5.2	6.7	8.2		
WSV6042	Flow Rate GPM [l/min]	7.0 [26.5]	9.0 [34.1]	11.0 [41.6]	13.0 [49.2]	15.0 [56.8]	17.0 [64.4]	19.0 [71.9]		
	Pressure Drop (psi)	1.4	2.1	3.0	4.1	5.2	6.6	8.0		
WSV6048	Flow Rate GPM [l/min]	12.0 [45.4]	14.0 [53.0]	16.0 [60.6]	18.0 [68.1]	20.0 [75.7]	Operation Not Recommended			
	Pressure Drop (psi)	2.6	3.5	4.7	5.9	7.4				
WSV6048 ECONOMIZER	Flow Rate GPM [l/min]	12.0 [45.4]	14.0 [53.0]	16.0 [60.6]	18.0 [68.1]	20.0 [75.7]			Operation Not Recommended	
	Pressure Drop (psi)	6.5	8.8	11.8	14.8	18.5				
WSV6060	Flow Rate GPM [l/min]	12.0 [45.4]	14.0 [53.0]	16.0 [60.6]	18.0 [68.1]	20.0 [75.7]	22.0 [83.3]	24.0 [90.8]		
	Pressure Drop (psi)	2.6	3.3	4.2	5.1	6.2	7.3	8.5		
WSV6060 ECONOMIZER	Flow Rate GPM [l/min]	12.0 [45.4]	14.0 [53.0]	16.0 [60.6]	18.0 [68.1]	20.0 [75.7]	22.0 [83.3]	24.0 [90.8]		
	Pressure Drop (psi)	6.0	8.2	10.6	13.4	16.5	19.9	23.7		
WSV6072	Flow Rate GPM [l/min]	12.0 [45.4]	14.0 [53.0]	16.0 [60.6]	18.0 [68.1]	20.0 [75.7]	22.0 [83.3]	24.0 [90.8]		
	Pressure Drop (psi)	2.6	3.3	4.2	5.1	6.2	7.3	8.5		
WSV6072 ECONOMIZER	Flow Rate GPM [l/min]	12.0 [45.4]	14.0 [53.0]	16.0 [60.6]	18.0 [68.1]	20.0 [75.7]	22.0 [83.3]	24.0 [90.8]		
	Pressure Drop (psi)	6.0	8.2	10.6	13.4	16.5	19.9	23.7		

First Co. / AE-Air reserves the right to change, alter, or update data, design features, and specifications without prior notice.

WIRE DIAGRAM MATRIX

Table 33: Wire Diagram Matrix							
Standard							
Unit		208-230/1/60	265/1/60	208-230/3/60	460/3/60		
WSV6009*	Std	WD80X004	WD80X005				
	DDC	WD80X065	WD80X066				
WSV6012*	Std	WD80X004	WD80X005				
	DDC	WD80X065	WD80X066				
WSV6018*	Std	WD80X001	WD80X002				
	DDC	WD80X069	WD80X070				
WSV6024*	Std	WD80X001	WD80X002			WD80X006	WD80X006
	DDC	WD80X069	WD80X070			WD80X071	WD80X072
WSV6030*	Std	WD80X001	WD80X002	WD80X006	WD80X006		
	DDC	WD80X069	WD80X070	WD80X071	WD80X072		
WSV6036*	Std	WD80X001	WD80X002	WD80X006	WD80X006		
	DDC	WD80X069	WD80X070	WD80X071	WD80X072		
WSV6042*	Std	WD80X050		WD80X051	WD80X051		
	DDC	WD80X061		WD80X063	WD80X064		
WSV6048*	Std	WD80X050		WD80X051	WD80X051		
	DDC	WD80X061		WD80X063	WD80X064		
WSV6060*	Std	WD80X050		WD80X051	WD80X051		
	DDC	WD80X061		WD80X063	WD80X064		
WSV6072*	Std	WD80X050		WD80X051	WD80X051		
	DDC	WD80X061		WD80X063	WD80X064		
Hot Gas Reheat							
Unit		208-230/1/60	265/1/60	208-230/3/60	460/3/60		
WSV6009*	Std	WD80X073	WD80X078				
	DDC	WD80X024	WD80X025				
WSV6012*	Std	WD80X073	WD80X078				
	DDC	WD80X024	WD80X025				
WSV6018*	Std	WD80X049	WD80X079				
	DDC	WD80X022	WD80X023				
WSV6024*	Std	WD80X049	WD80X079			WD80X077	WD80X080
	DDC	WD80X022	WD80X023			WD80X028	WD80X029
WSV6030*	Std	WD80X049	WD80X079	WD80X077	WD80X080		
	DDC	WD80X022	WD80X023	WD80X028	WD80X029		
WSV6036*	Std	WD80X049	WD80X079	WD80X077	WD80X080		
	DDC	WD80X022	WD80X023	WD80X028	WD80X029		
WSV6042*	Std	WD80X044		WD80X074	WD80X075		
	DDC	WD80X056		WD80X057	WD80X058		
WSV6048*	Std	WD80X044		WD80X074	WD80X075		
	DDC	WD80X056		WD80X057	WD80X058		
WSV6060*	Std	WD80X044		WD80X074	WD80X075		
	DDC	WD80X056		WD80X057	WD80X058		
WSV6072*	Std	WD80X044		WD80X074	WD80X075		
	DDC	WD80X056		WD80X057	WD80X058		
Economizer							
Unit		208-230/1/60	265/1/60	208-230/3/60	460/3/60		
WSV6048*	Std	WD80X055		WD80X054	WD80X054		
WSV6060*	Std	WD80X055		WD80X054	WD80X054		
WSV6072*	Std	WD80X055		WD80X054	WD80X054		

First Co. / AE-Air reserves the right to change, alter, or update data, design features, and specifications without prior notice.

WIRING DIAGRAMS

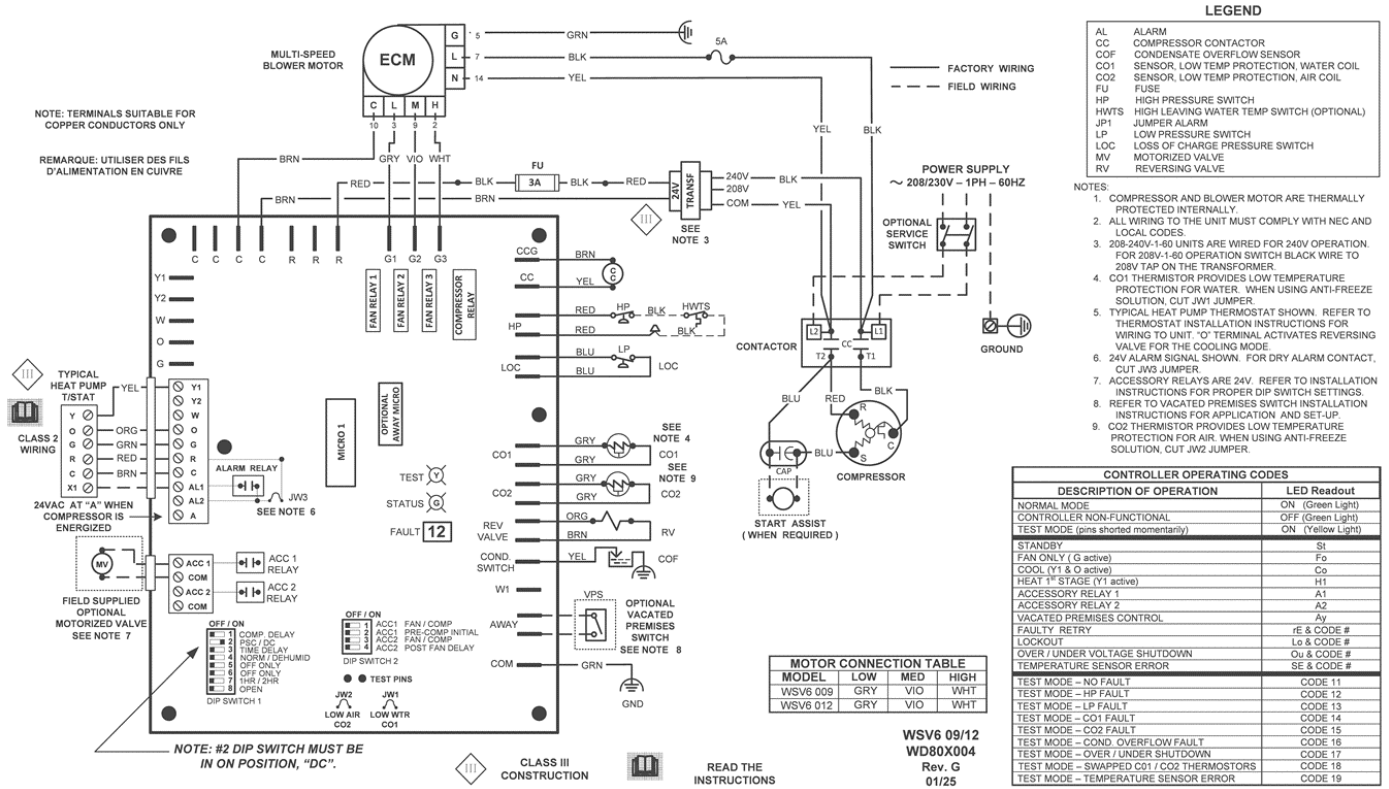

Figure 19 - WD80X004

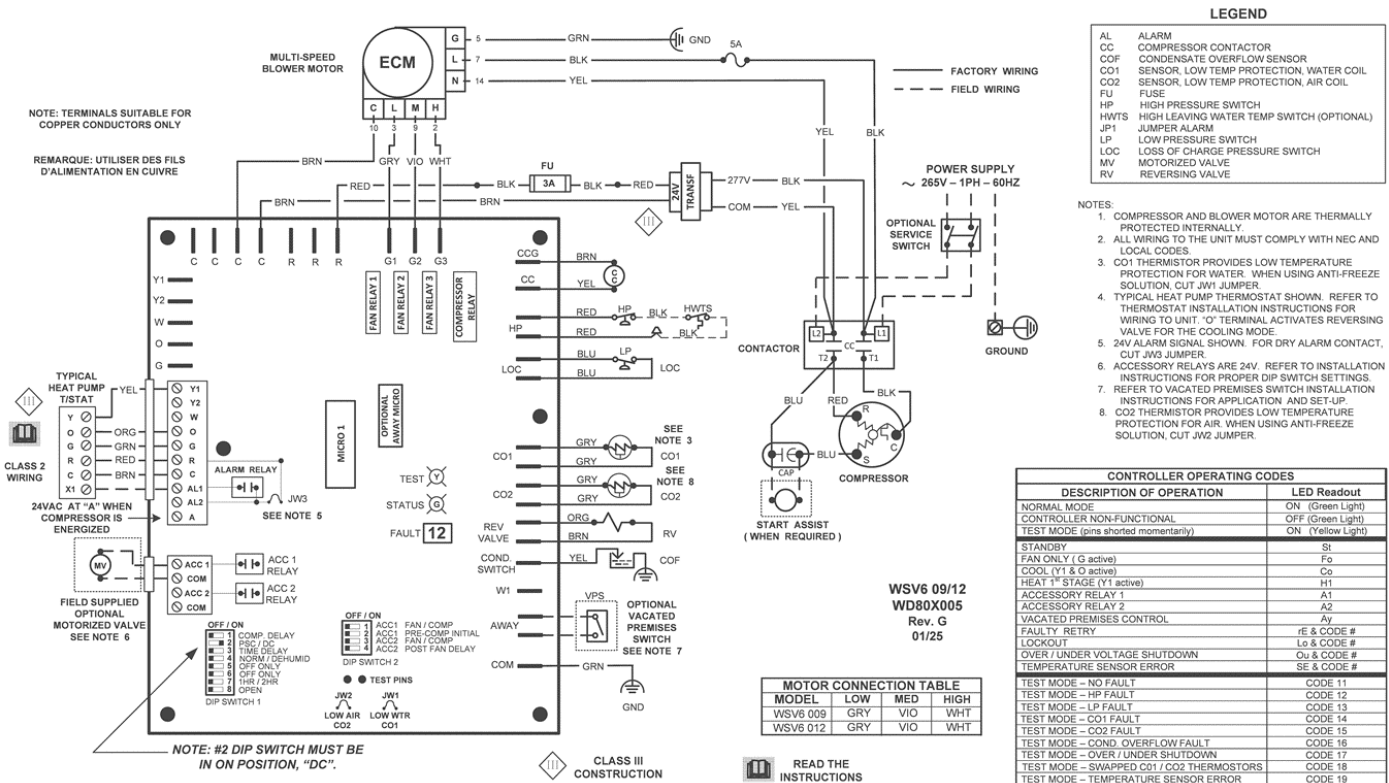

Figure 20 - WD80X005

First Co. / AE-Air reserves the right to change, alter, or update data, design features, and specifications without prior notice.

WIRING DIAGRAMS (CONTINUED)

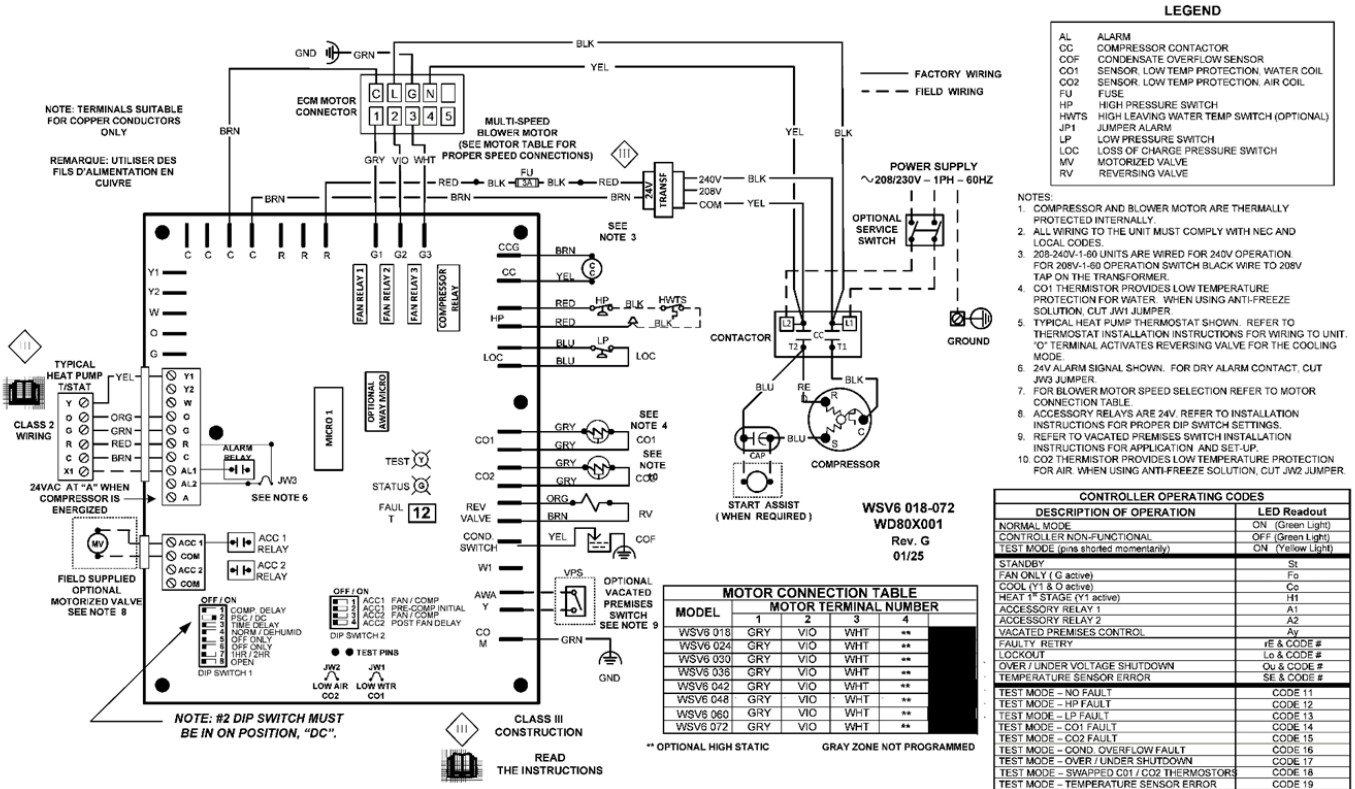

Figure 21 - WD80X001

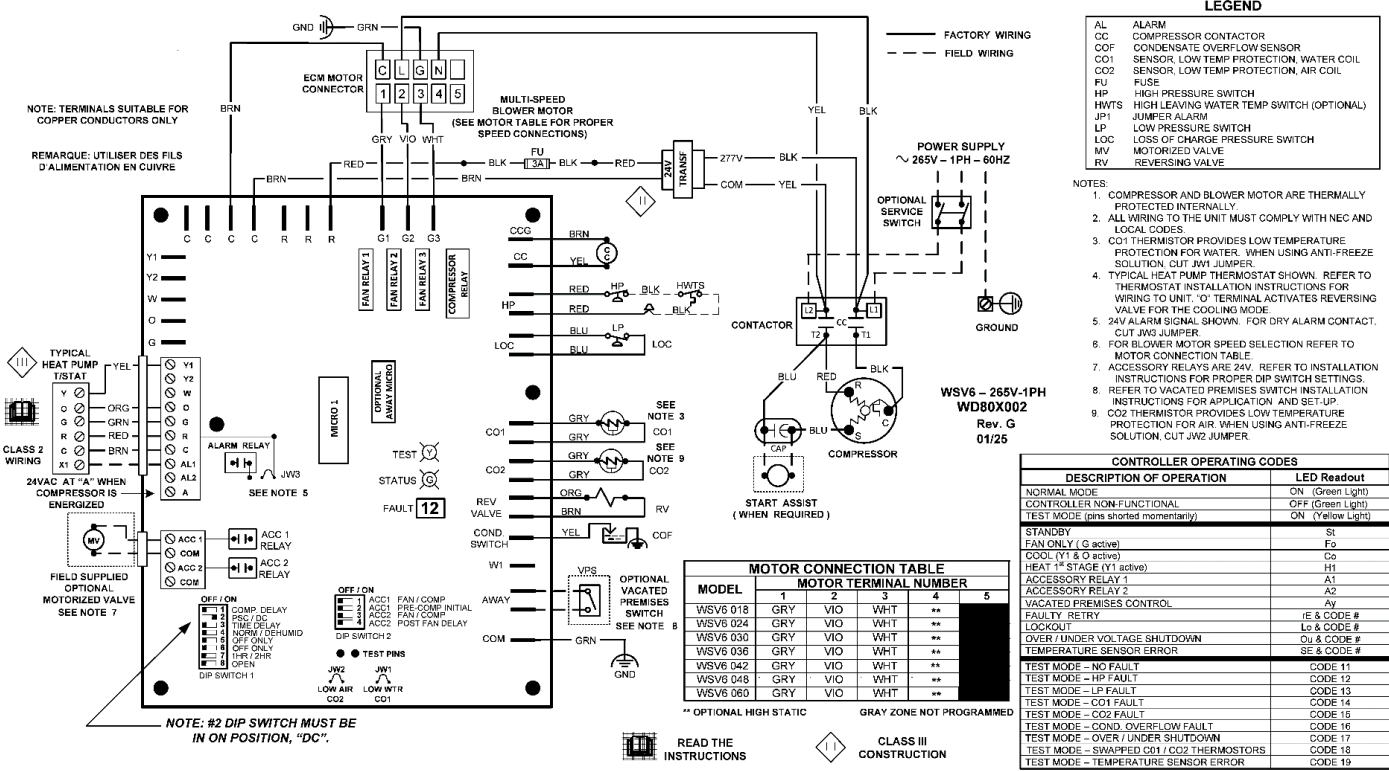

Figure 22 - WD80X002

First Co. / AE-Air reserves the right to change, alter, or update data, design features, and specifications without prior notice.

WIRING DIAGRAMS (CONTINUED)

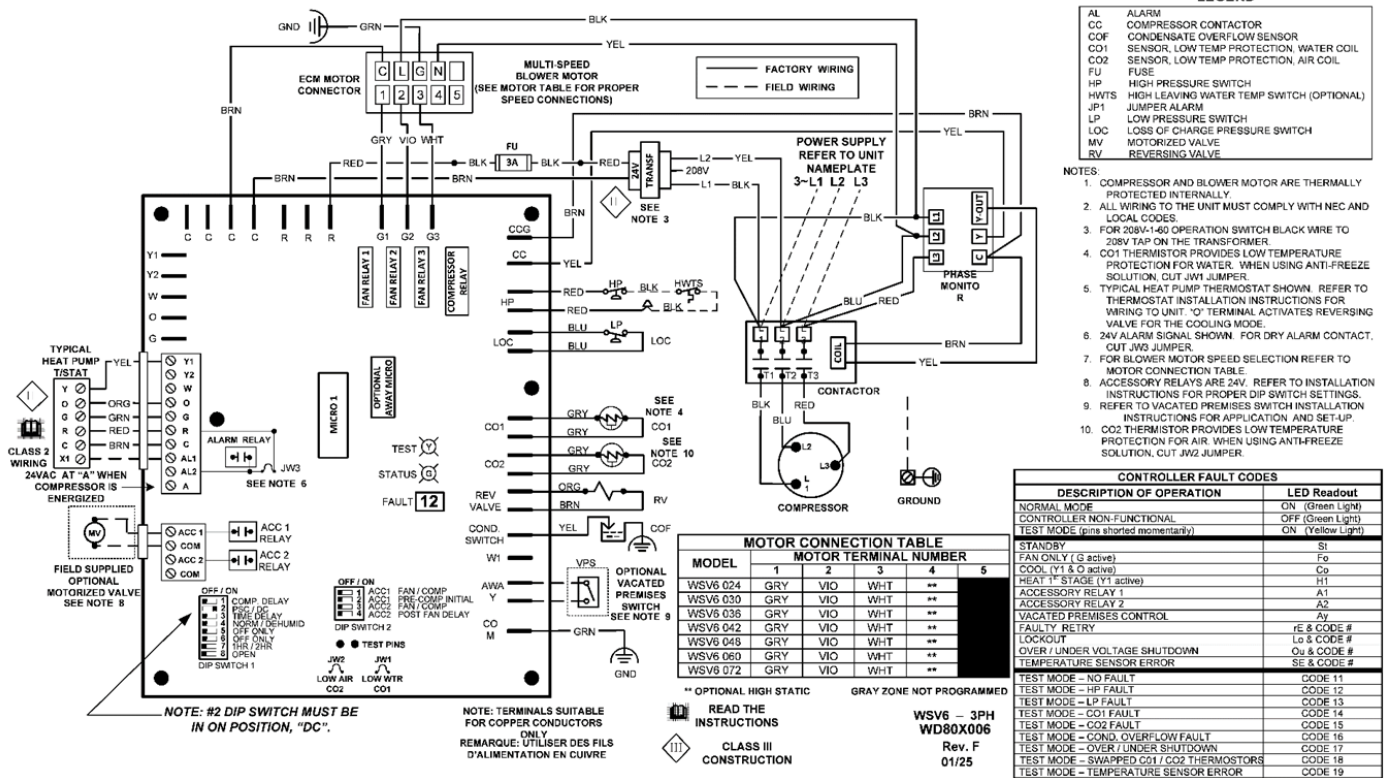

Figure 23 - WD80X006

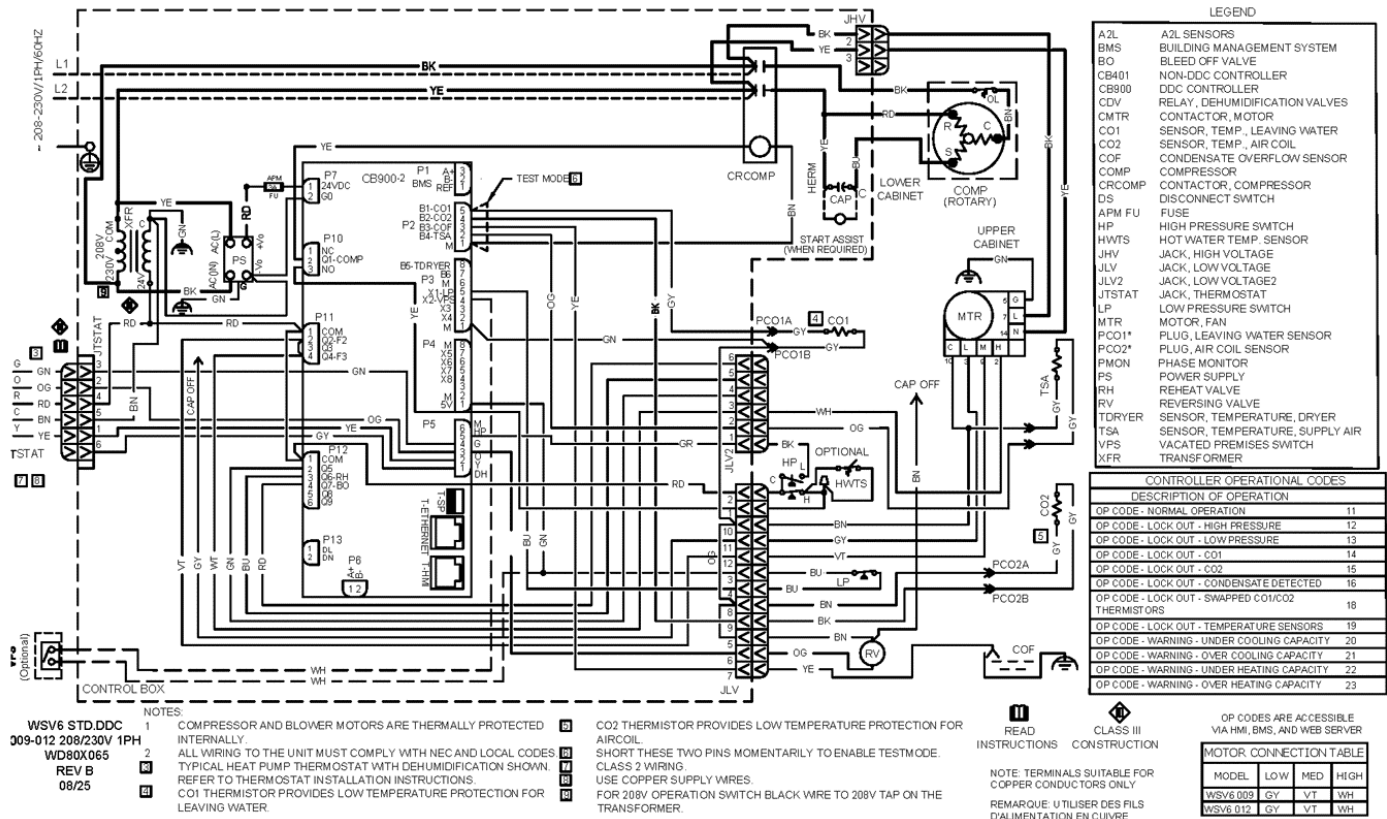

Figure 24 - WD80X065

First Co. / AE-Air reserves the right to change, alter, or update data, design features, and specifications without prior notice.

WIRING DIAGRAMS (CONTINUED)

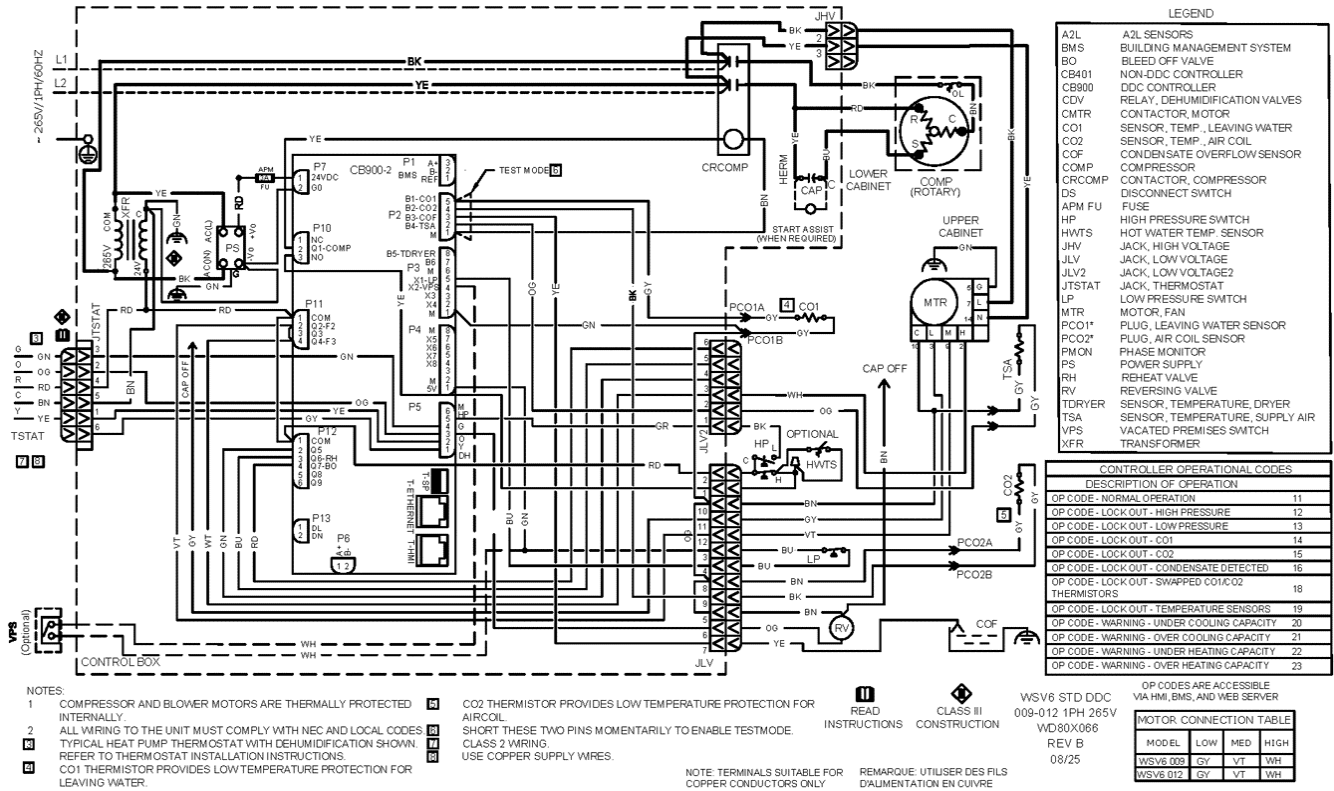

Figure 25 - WD80X066

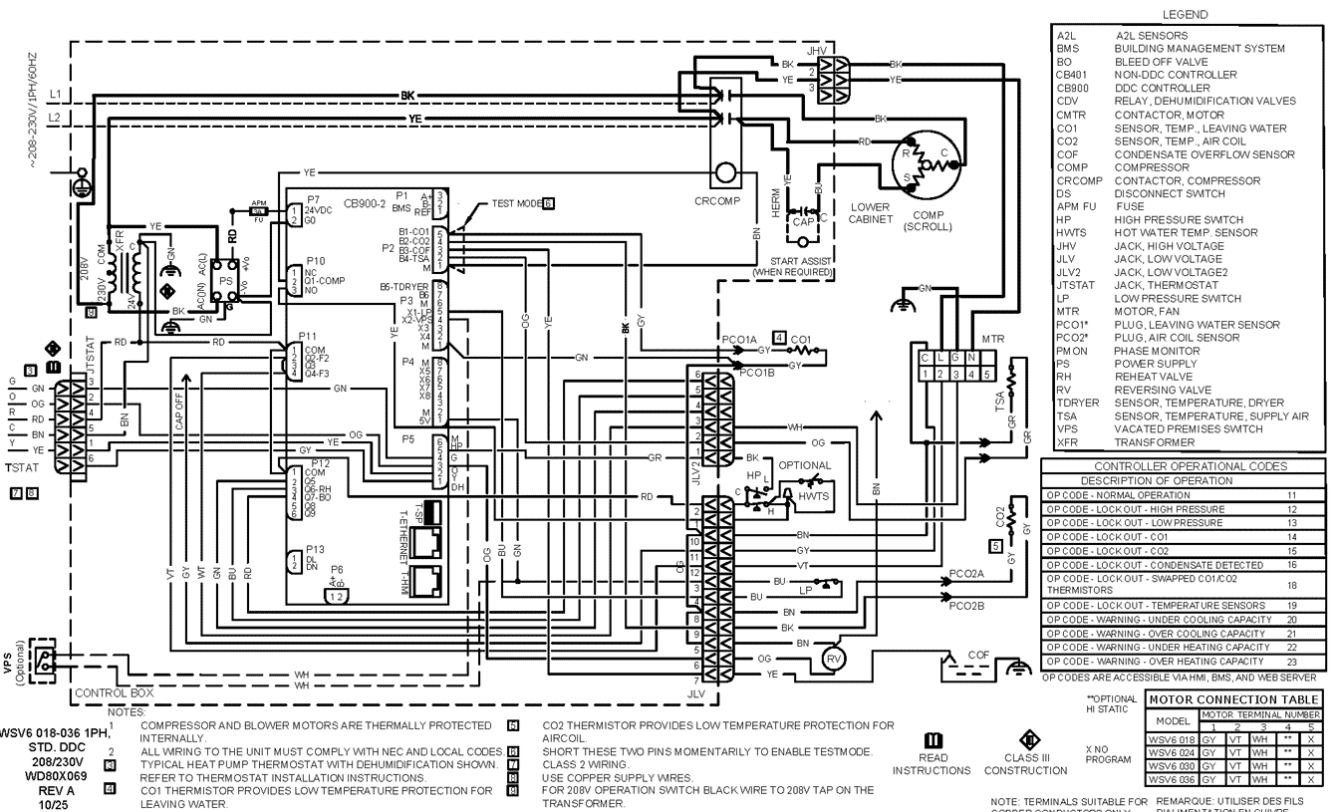

Figure 26 - WD80X069

First Co. / AE-Air reserves the right to change, alter, or update data, design features, and specifications without prior notice.

WIRING DIAGRAMS (CONTINUED)

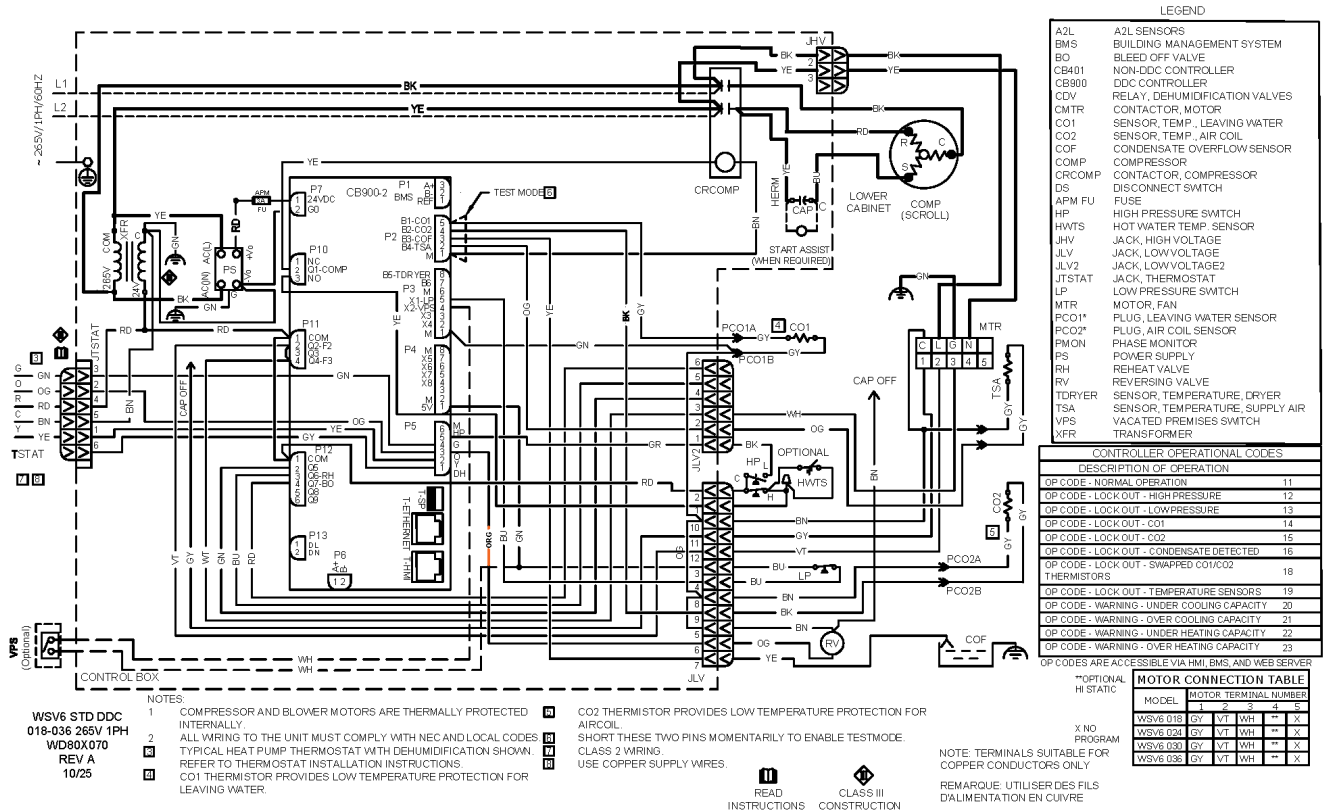

Figure 27 - WD80X070

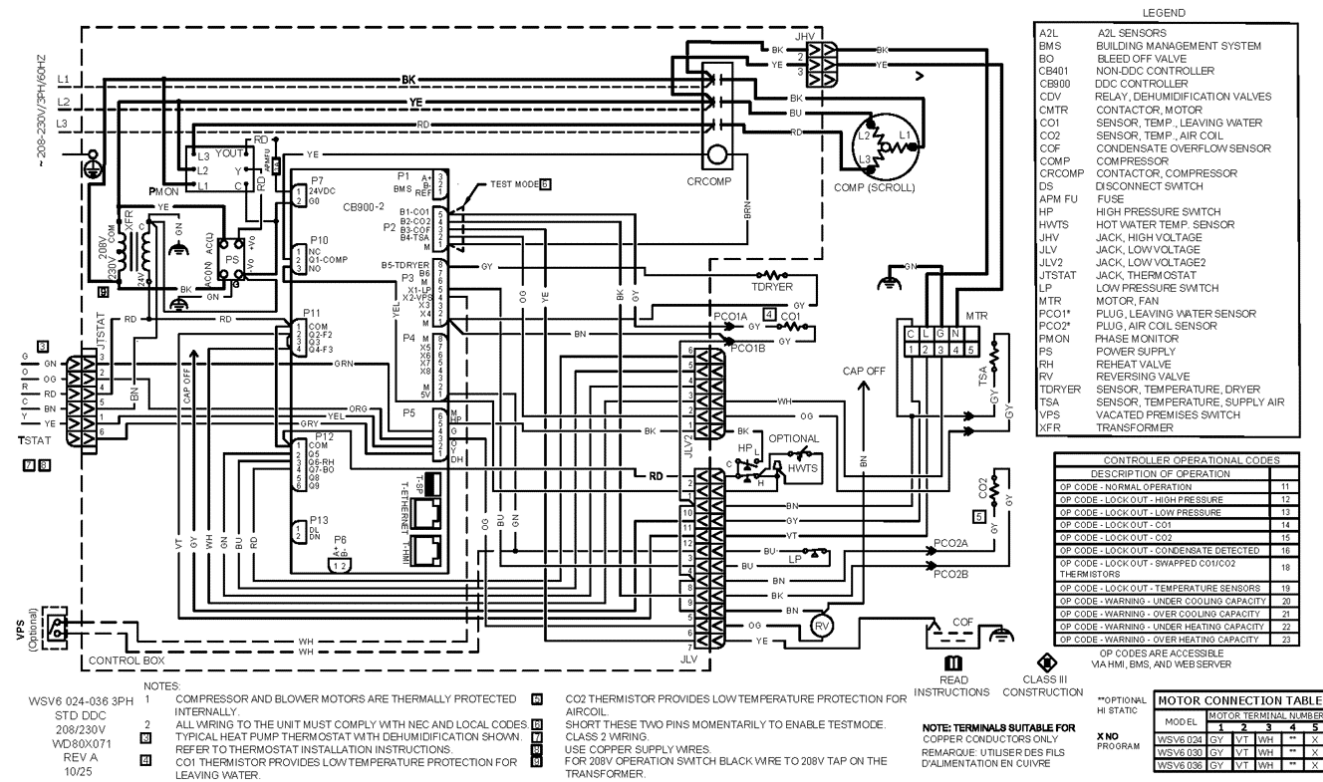

Figure 28 - WD80X071

First Co. / AE-Air reserves the right to change, alter, or update data, design features, and specifications without prior notice.

WIRING DIAGRAMS (CONTINUED)

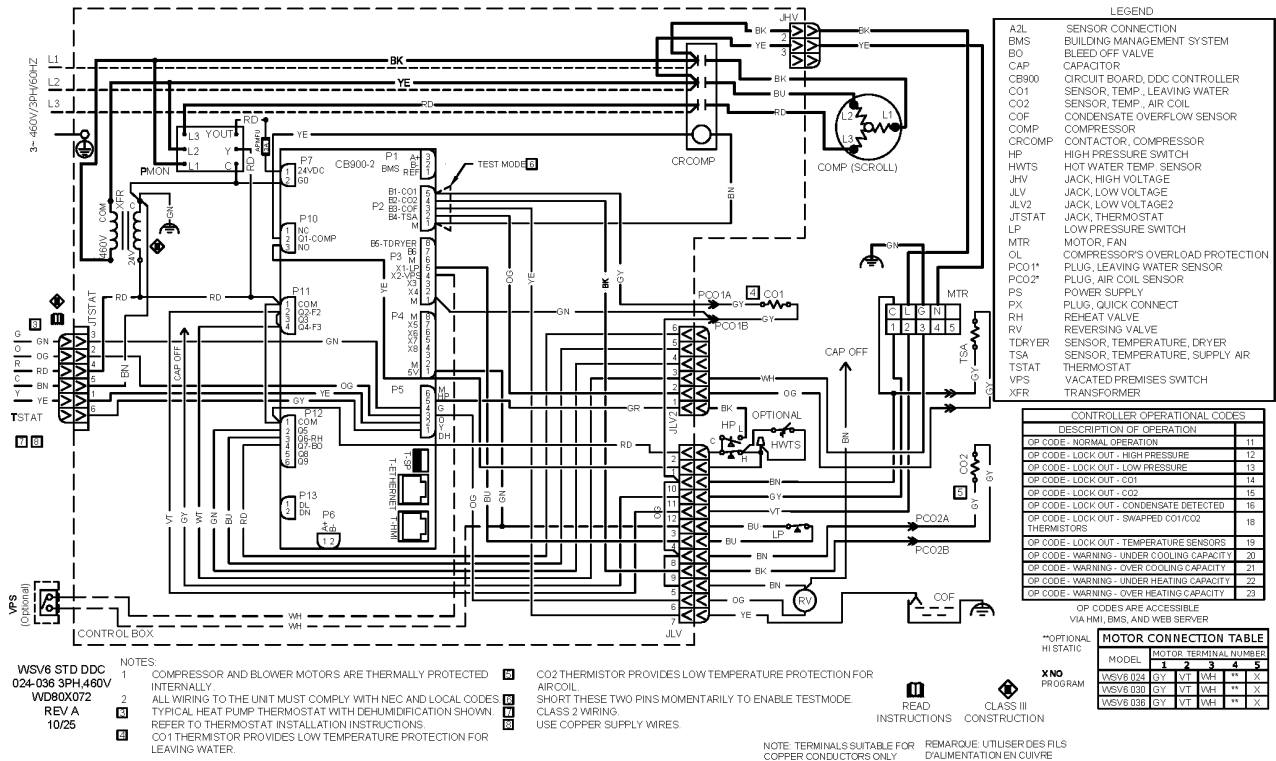

Figure 29 - WD80X072

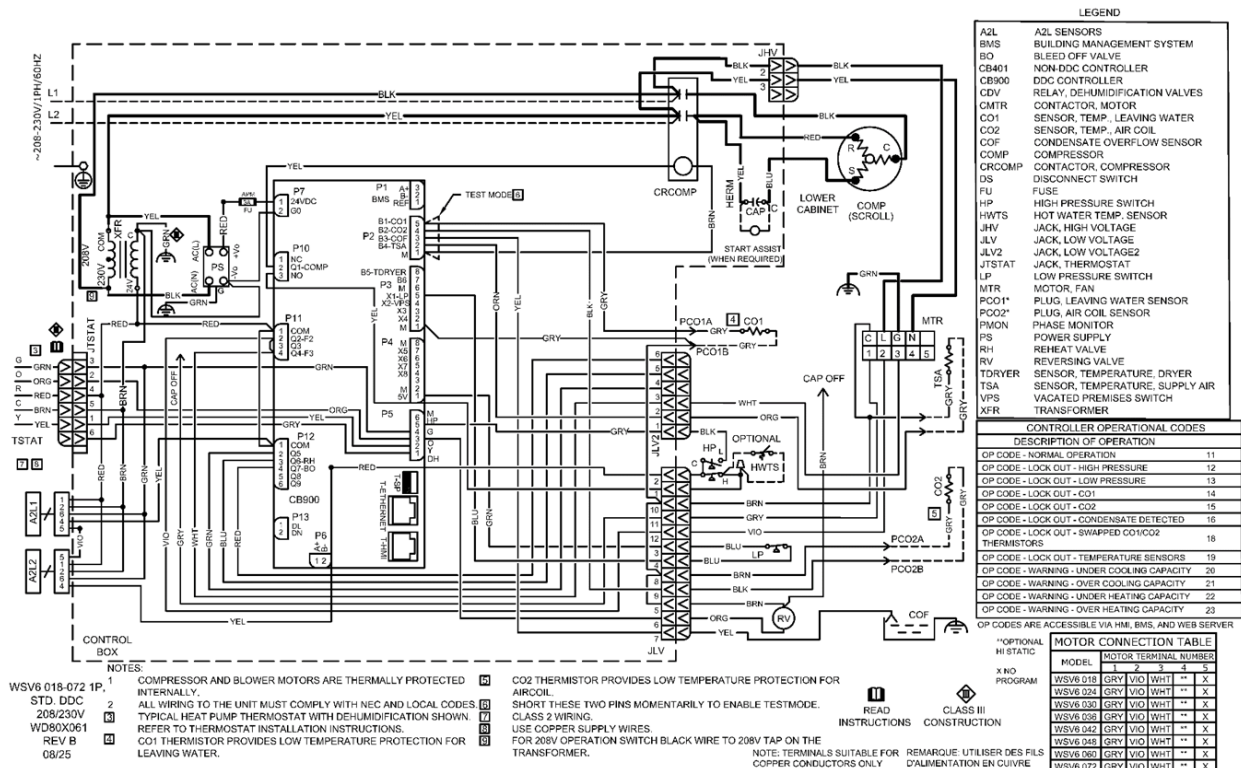

Figure 30 - WD80X061

First Co. / AE-Air reserves the right to change, alter, or update data, design features, and specifications without prior notice.

WIRING DIAGRAMS (CONTINUED)

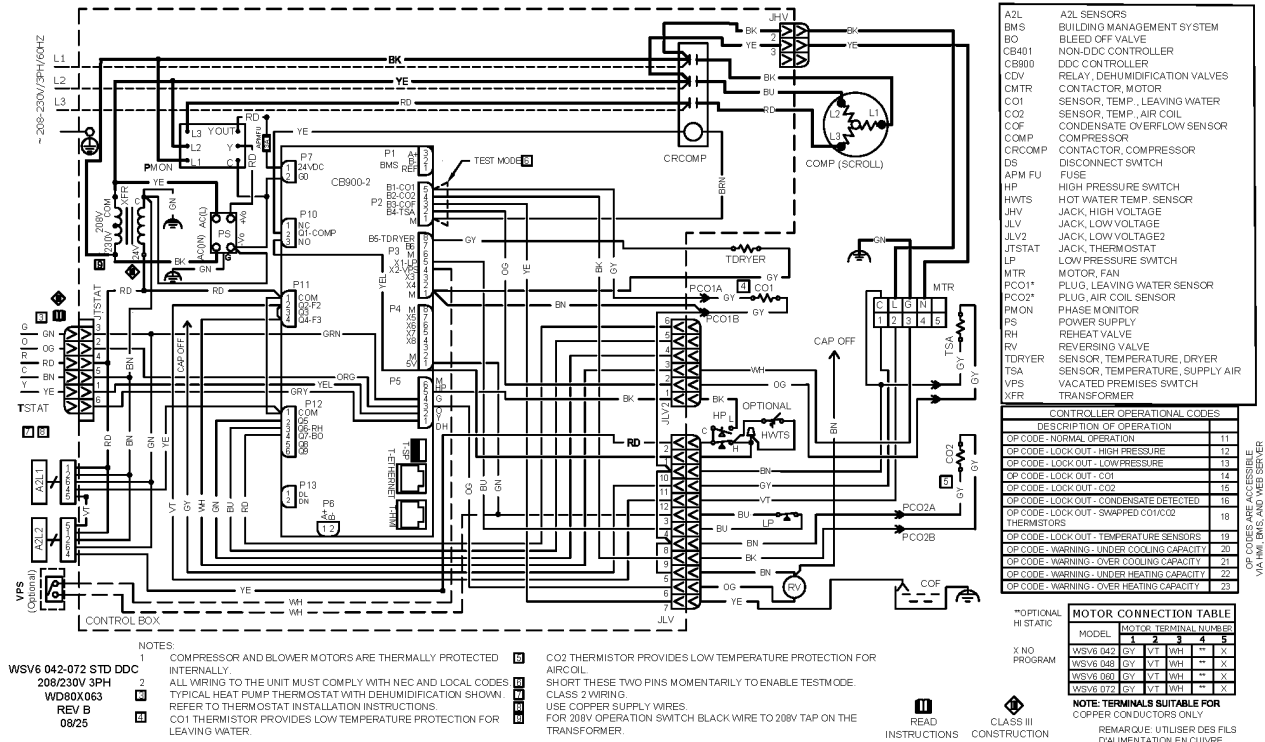

Figure 31 - WD80X063

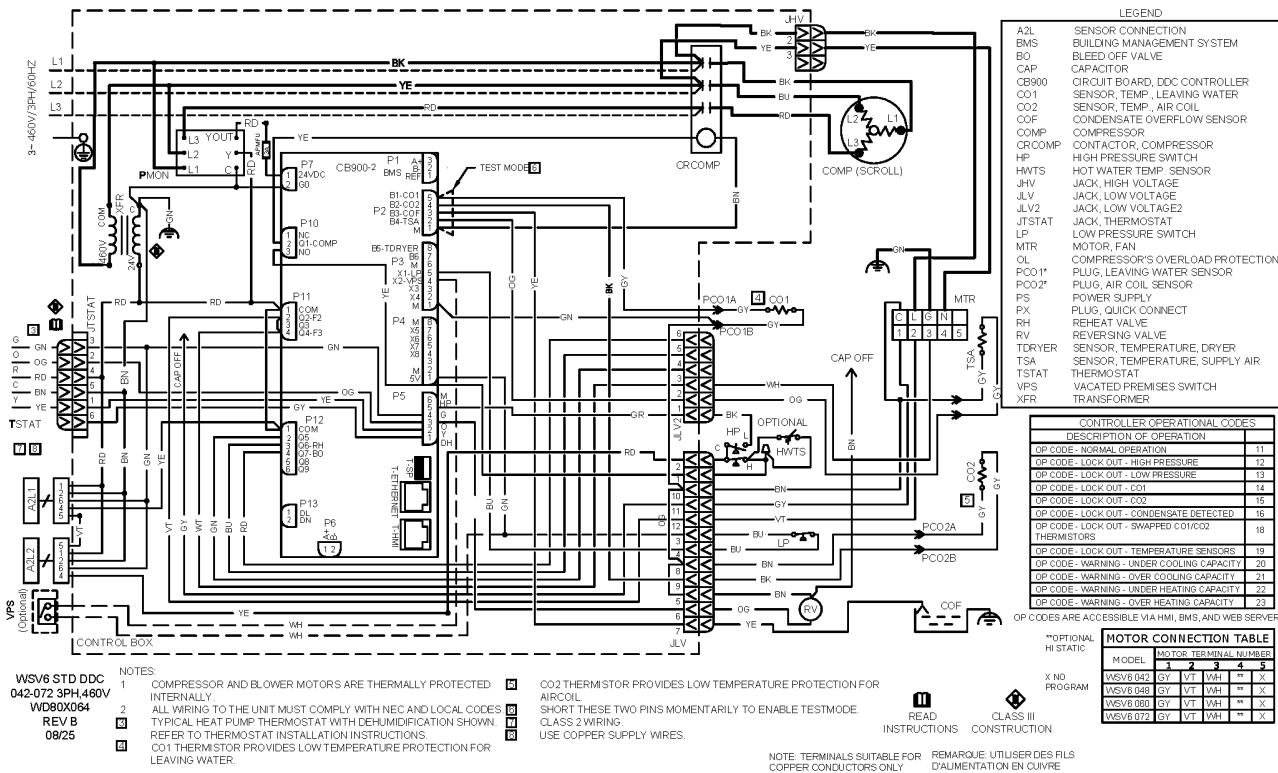

Figure 32 - WD80X064

First Co. / AE-Air reserves the right to change, alter, or update data, design features, and specifications without prior notice.

CIRCUIT SCHEMATICS

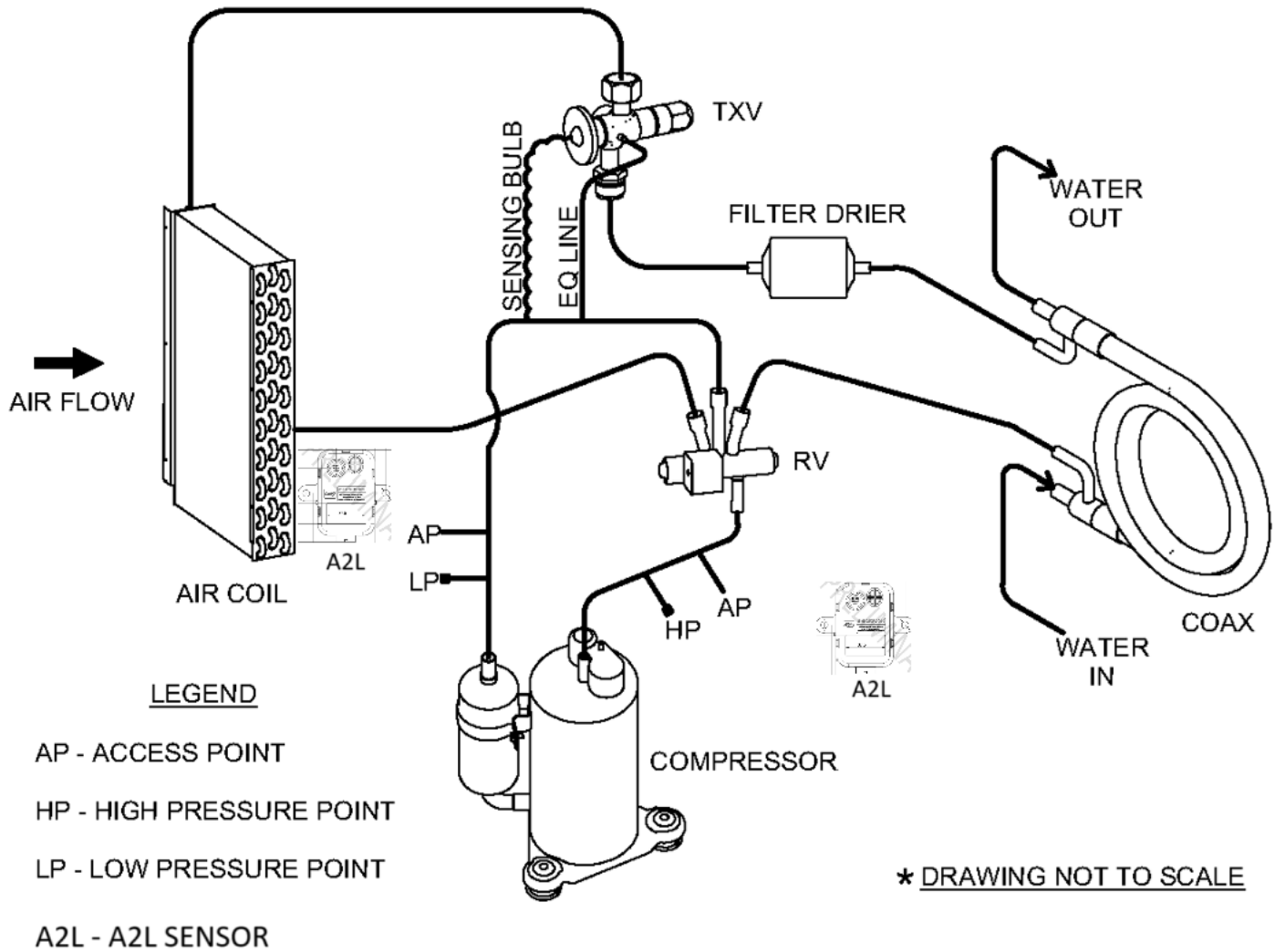

Figure 33 - Circuit Diagram

CIRCUIT SCHEMATICS - HGRH

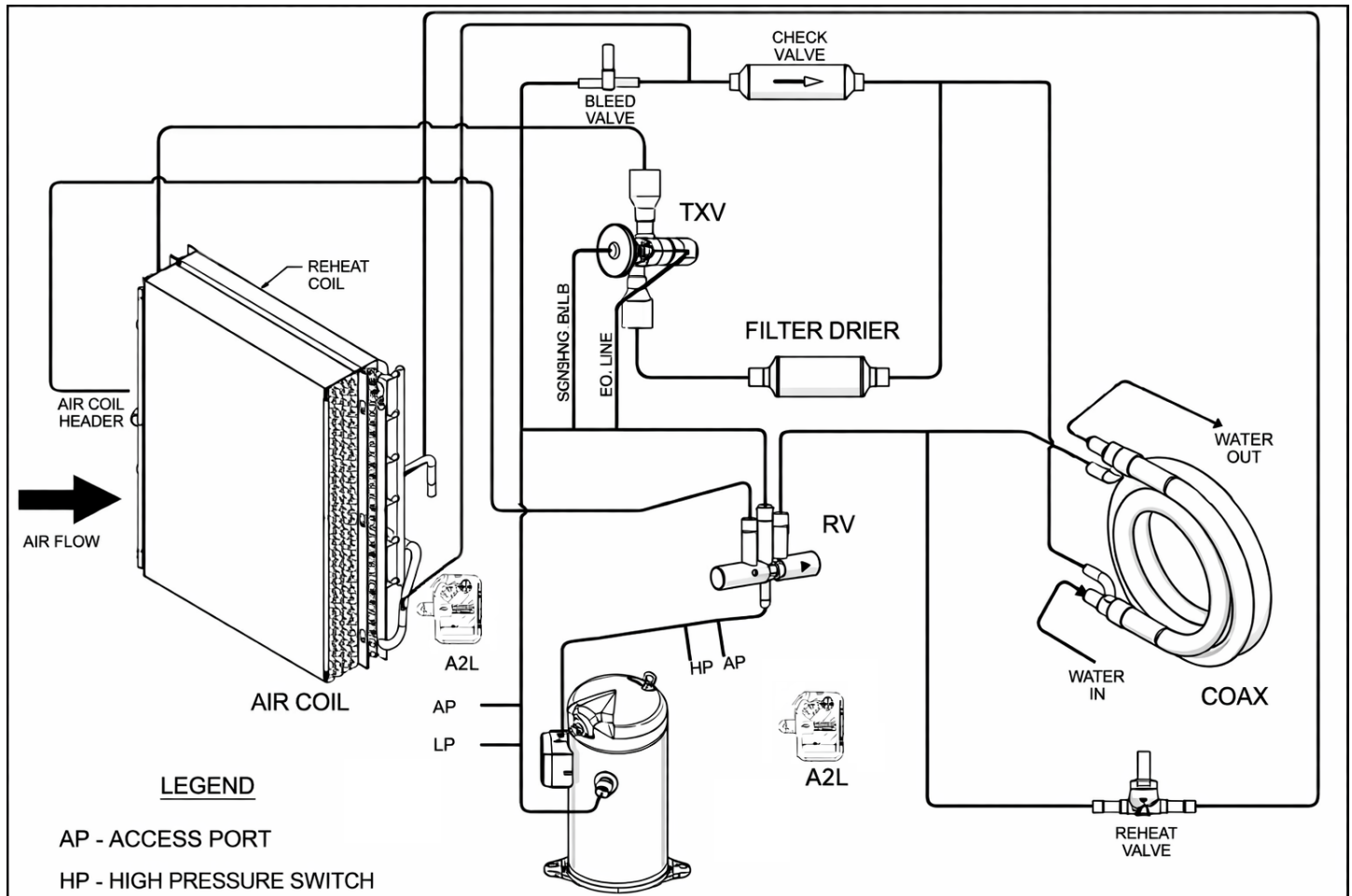



Figure 34 - Circuit Diagram HGRH

PRE-STARTUP INSPECTION

 WARNING 
Connect the ground wire to the terminal marked "GND". Failure to do so may result in personal injury or death.

 CAUTION 
All factory-supplied devices for field installation must be wired exactly as shown on the provided wiring diagram. Failure to comply may damage components and void all warranties.

PRE-STARTUP CHECKS

Before startup, thoroughly inspect all components. Proper equipment operation requires a clean installation.

Construction activities performed after equipment installation may introduce debris. Protect the unit from contamination during all construction phases.

PRIOR TO UNIT STARTUP

Before energizing the unit, verify the following:

1. The supply voltage matches the unit nameplate rating.
2. The unit is properly grounded.
3. With power OFF, blower wheel set screws are secure and the blower wheel rotates freely.
4. The unit is accessible for service and maintenance.
5. The condensate drain line is properly sized, routed, trapped, pitched, and tested.
6. All cabinet penetrations and wiring connections are properly sealed.
7. Clean air filters are installed.
8. All access panels are properly installed and secured.
9. The water coil and associated piping have been leak tested and insulated as required.
10. All air has been fully vented from the water coil.
11. All electrical connections are tight and secure.
12. Electrical overcurrent protection and wiring are correctly sized and installed.
13. Low-voltage wiring between the thermostat and the unit conforms to the applicable wiring diagram.
14. Water piping installation is complete and correct.
15. The condensate overflow sensor operates correctly and is properly positioned.

After completing the above checks, ensure that power is connected to the unit and that the local disconnect is in the ON position.

STARTUP & PERFORMANCE CHECKLIST

1. Place the main disconnect switch in the ON position.
2. Verify the presence of 24 VAC at the control transformer. The controller module LED shall illuminate.
 - a. If the LED does not illuminate, the power supply is out of phase.
 - b. Turn OFF the main power disconnect and correct phase rotation by interchanging any two incoming power leads.
3. Set the thermostat to its lowest temperature setting. Set the system switch to COOL and the fan switch to AUTO. The reversing valve shall energize.
4. After the 5–80 second random start delay, verify that the blower starts and the compressor operates.
5. Verify correct compressor rotation.
 - a. If rotation is incorrect, turn power OFF and correct the rotation.
 - b. For three-phase units, rotation may be corrected by interchanging any two compressor power leads.
6. Set the thermostat system switch to OFF. Verify that the unit stops operating and that the reversing valve de-energizes.
7. Leave the unit OFF for approximately 5 minutes to allow system pressures to equalize. The built-in anti-short-cycle protection will prevent compressor operation during this period.
8. Set the thermostat to its highest temperature setting and place the system switch in the HEAT position.
9. Verify that the unit operates in heating mode.
10. Adjust the thermostat to maintain the desired space temperature.
11. Inspect the unit for abnormal vibration, noise, or leaks.
12. Verify that the water flow rate meets the unit specification. Adjust as required.
 - a. If specifications are unavailable, the nominal flow rate is 25 GPM.

Instruct the owner on proper unit and thermostat operation.

WARRANTY NOTICE

Completion and return of the Startup & Performance Checklist may be required to validate warranty coverage. Failure to properly install or commission the WSV6 unit may result in voided warranty, as the manufacturer is not responsible for failures resulting from improper installation.

STARTUP & PERFORMANCE CHECKLIST



For extended warranty registration, email form to returns@firstco.com
 For startup assistance, email form to techsupport@firstco.com

Customer: _____	Order Date: _____	Startup Date: _____
Street Address: _____	Phone #: _____	Job #: _____
Installing Contractor: _____	Technician: _____	
MODEL #: _____	Serial # (ex: A-12-B-345678): _____	

Visual Inspection

- Air Filter Condition
- Evaporator Coil Condition
- Blower Wheel
- Sweating on plenum/cabinet
- Signs of condensate outside pan
- Condensate drain clear

Installed Accessories

- Hard Start Kit
Type/Brand _____
- Compressor Cover
- Vacated Premises Switch

Controller Switch Positions

Dip Switch 1	Dip Switch 2
<i>Off On</i>	<i>Off On</i>
<input type="checkbox"/> <input type="checkbox"/> Switch #1	<input type="checkbox"/> <input type="checkbox"/> Switch #1
<input type="checkbox"/> <input type="checkbox"/> Switch #2	<input type="checkbox"/> <input type="checkbox"/> Switch #2
<input type="checkbox"/> <input type="checkbox"/> Switch #3	<input type="checkbox"/> <input type="checkbox"/> Switch #3
<input type="checkbox"/> <input type="checkbox"/> Switch #4	<input type="checkbox"/> <input type="checkbox"/> Switch #4
<input type="checkbox"/> <input type="checkbox"/> Switch #5	
<input type="checkbox"/> <input type="checkbox"/> Switch #6	
<input type="checkbox"/> <input type="checkbox"/> Switch #7	
<input type="checkbox"/> <input type="checkbox"/> Switch #8	

Unit in Lock Out? _____

Fault Code in Test Mode? _____

Unit Operation

Primary Voltage to Heat Pump: _____
 Transformer Secondary Voltage: _____
 Unit Grounded? _____

Low Side PSIG: _____ Vapor Line Temp: _____ Saturated Temp: _____
 [Vapor Line Temp - Saturated Temp = Super Heat]

High Side PSIG: _____ Saturated Temp: _____ Liquid Line Temp: _____
 [Saturated Temp - Liquid Line Temp = Subcooling]

Duct System Static Pressure

Supply Static Pressure: _____
 Return Static Pressure: _____
 Total External Static Pressure: _____

Evaporator Coil Temperatures

Evaporator EAT Dry Bulb: _____
 Evaporator LAT Dry Bulb: _____
 Delta: _____
 Evaporator EAT Wet Bulb: _____
 Evaporator LAT Wet Bulb: _____
 Delta: _____

Heat Exchanger Temperature

Condenser EWT: _____
 Condenser LWT: _____
 Delta: _____

STARTUP & PERFORMANCE CHECKLIST



For extended warranty registration, email form to returns@firstco.com
 For startup assistance, email form to techsupport@firstco.com

Problem Summary

Corrective Actions Taken

The warranty shall be considered void unless the Startup & Performance Checklist is properly completed and submitted to the warrantor. In addition, any failure to install the unit in accordance with the manufacturer's published instructions and applicable codes shall render the warranty null and void. The manufacturer shall not be held liable for any damages, failures, or performance issues arising from improper installation, adjustment, or application of the equipment.

OPERATION & MAINTENANCE

PREVENTIVE MAINTENANCE

To ensure maximum performance, reliability, and service life, a formal preventive maintenance schedule shall be established and followed.







	CAUTION	
Appropriate personal protective equipment (PPE) shall be worn when servicing or maintaining this unit. Sharp metal edges, moving components, and hot or cold surfaces may cause personal injury.		

Table 34: Preventative Maintenance Schedule

Component	Maintenance Task	Interval
Air Filters	Inspect and clean or replace as required	Monthly
Blower Assembly	Inspect blower wheel for dirt accumulation; check set screws and rotation	Quarterly
Electrical Connections	Inspect for tightness, discoloration, or damage	Semiannually
Condensate Drain System	Inspect drain pan, trap, and piping; clean and test for proper drainage	Quarterly
Condensate Overflow Sensor	Verify proper operation and positioning	Semiannually
Water Coil	Inspect for fouling, corrosion, or leaks	Semiannually
Water Piping	Inspect insulation, fittings, and connections for leaks	Semiannually
Air Venting (Water Coil)	Verify all trapped air has been purged	At Startup and Annually
Refrigerant Circuit	Inspect for signs of leakage or oil residue	Annually
Compressor	Observe operation for abnormal noise or vibration	Annually
Safety Controls & Sensors	Verify operation of pressure switches, temperature sensors, and protections	Annually
Controls & Setpoints	Verify control settings, DIP switches, and sequence of operation	Annually
Economizer / Reheat Components (if equipped)	Inspect valves, coils, and control operation	Annually
General Unit Condition	Inspect cabinet, panels, fasteners, and seals	Annually

FAN

The fan assembly shall be inspected and cleaned annually in conjunction with maintenance of the motor and bearings. The fan section and motor shall be kept clean and free of obstructions to prevent imbalance, vibration, and improper operation.

	WARNING	
	ELECTRIC SHOCK HAZARD	
Check motor connections to ensure they are secure and in accordance with the unit wiring diagram.		
ECM motors have line voltage power applied at all times. Ensure all power is disconnected before servicing.		

AIR FILTER

The air filter shall be cleaned or replaced every 30 days, or more frequently under severe operating conditions. Replace filters only with the same type and size as originally provided.

COIL

All heat transfer surfaces shall be cleaned to remove dirt, dust, and contaminants that may impair airflow or heat transfer. Cleaning shall be performed using industry-accepted methods. Care shall be taken to avoid damage to or bending of coil fins.

CONDENSATE DRAIN PAN AND PIPE

Inspect and clean the condensate drain pan to remove all dirt and debris. Verify that the condensate drain line is free-flowing and unobstructed.

OPERATION & MAINTENANCE (CONTINUED)

MAINTENANCE UPDATES

Check regularly for the most current copy of the unit's IOM, which can be found at firstco.com or ae-air.com.

CLEANING / FLUSHING

Before connecting the unit to the building water supply, the water circulating system shall be cleaned and flushed to remove dirt, debris, and contaminants.

1. Connect the supply and return water lines together to bypass the unit. This prevents debris from entering the unit during the flushing process.
2. Start the main water circulating pump and allow water to circulate through the system. Open drains at the lowest points in the system and drain water while simultaneously refilling the loop with clean city water. Continue flushing for a minimum of two (2) hours, or until discharge water is clear. During flushing, inspect the system for leaks.
3. Open all drains and vents to fully drain the system, then refill with clean water. Test system water quality and treat as required to meet system specifications. Maintain water pH between 7.5 and 8.5. Add antifreeze if required for the application.
4. Connect the water-source heat pump supply and return lines in accordance with the piping installation instructions. After verifying that all connections are leak-free, bring the water loop to the required operating setpoint and vent all trapped air from the system.

UNIT PERFORMANCE

Record operating performance data, including voltage, current, and water temperature differential in both heating and cooling modes. Comparison of recorded data with startup and annual performance records is recommended to evaluate overall equipment condition.

UNIT LOCKOUT

Periodic unit lockouts may occur due to airflow or water-side conditions. Lockout events are a normal protective function of the control system. If lockouts occur, inspect the following:

- Water system cleanliness
- Water flow rate
- Water temperature
- Airflow rate (including filter condition)
- Entering and leaving air temperatures

Correct any identified deficiencies before returning the unit to service.

INITIAL COIL CLEANING

For units with less than 100 operational hours, the coils may not have had sufficient time to "season." Clean the coils using a coil cleaning spray, which is available at most hardware stores, or a mild surfactant, such as dish soap mixed with warm water, to remove oils and residues left from the manufacturing process.

PUMP REPLACEMENT

1. Disconnect electrical power before servicing the unit.
2. Close the water system isolation valves and relieve pressure from the heating loop.
3. Disconnect the pump's 115 VAC power leads inside the control enclosure.
4. Remove the four hex-head fasteners securing the pump motor to the pump volute.
5. Remove the pump motor.

To reinstall, reverse the above steps. Ensure the rubber O-ring is properly installed between the pump and volute before assembly.

CHECK VALVE REPLACEMENT

1. Close the water system isolation valves and relieve pressure from the heating loop.
2. Remove the four hex-head fasteners securing the pump motor to the pump volute and remove the motor.
3. Locate the check valve inside the volute.
4. Rotate the check valve to release and remove it from the volute.

Reinstall the check valve by reversing the above steps. Verify the rubber O-ring is properly seated before reassembly.

OPERATION & MAINTENANCE (CONTINUED)

REFRIGERANT DETECTION SENSOR (RDS) INFORMATION — A2L APPLICATIONS

Units utilizing A2L refrigerants are equipped with a factory-installed Refrigerant Detection System (RDS). The RDS continuously monitors the evaporator coil and internal refrigerant-containing components for refrigerant leakage.

Upon detection of an A2L refrigerant leak, the control system shall automatically initiate mitigation actions to reduce the risk of ignition or fire, in accordance with applicable safety standards.

Refer to **Table 1 - A2L Sensing & Mitigation** for information regarding minimum conditioned room requirements and detailed instructions for RDS operation, installation, and wiring.

Any field-installed wiring connected to the RDS shall be a minimum of 18 AWG and shall have a minimum insulation thickness of 1.6 mm, or shall be otherwise protected from mechanical damage.

The RDS is not serviceable or repairable. In the event of a sensor failure, the control system shall initiate mitigation mode, and the sensor shall be replaced in its entirety by removing the existing sensor and installing a new, approved replacement.

False ceilings or drop ceilings may be used as a return air plenum only when a refrigerant detection system is installed in the appliance and any external refrigerant-containing connections are also provided with a sensor located immediately below the return air plenum duct connection.

QUALIFICATION OF WORKERS

Service shall be performed only by qualified personnel. Technicians shall be certified by nationally recognized training organizations or manufacturers accredited to teach applicable national competency standards, as required by legislation. Technician competence to service the appliance shall be documented by certification.

WORK AREA SAFETY CHECKS

Before beginning any work on the appliance, perform safety inspections to ensure the risk of igniting released gases is minimized. All work shall be conducted under controlled conditions to reduce the likelihood of flammable gas or vapor presence during servicing or maintenance.

All personnel working in or near the area must be informed of the nature of the work being performed and the associated safety precautions. Work in confined spaces must be strictly avoided.

CHECKING FOR PRESENCE OF REFRIGERANT

The work area shall be checked using an appropriate refrigerant detector both before and during servicing to ensure the technician is aware of potentially toxic or flammable atmospheres.

Leak detection equipment shall be suitable for the refrigerant in use, and shall be non-sparking, adequately sealed, or intrinsically safe, as applicable.

If hot work is to be performed on refrigerating equipment or associated components, appropriate fire-extinguishing equipment shall be immediately available. A dry powder or CO₂ fire extinguisher shall be located adjacent to the charging or service area.

No person performing work on a refrigerating system that involves exposure of refrigerant-containing piping or components shall use any source of ignition in a manner that could create a risk of fire or explosion. All potential ignition sources, including smoking, shall be kept sufficiently distant from the installation, service, removal, or disposal area where refrigerant may be released.

Prior to commencing work, the area surrounding the equipment shall be surveyed to confirm the absence of flammable materials or ignition hazards. "NO SMOKING" signage shall be displayed.

OPERATION & MAINTENANCE (CONTINUED)

VENTILATION REQUIREMENTS

Before opening the refrigerant circuit or performing hot work, ensure the area is open to atmosphere or adequately ventilated. Ventilation shall be maintained for the entire duration of the work. Ventilation shall be sufficient to safely disperse any released refrigerant and, where practicable, discharge it to the outdoors.

CHECKS TO THE REFRIGERATING EQUIPMENT

When replacing electrical or refrigerating components, components shall be fit for purpose and conform to the correct specification. The manufacturer's installation, maintenance, and service instructions shall be followed at all times. If uncertainty exists, consult the manufacturer's technical support.

For installations using flammable refrigerants, the following conditions shall be verified:

- The actual refrigerant charge complies with the room size limitations for the space containing refrigerant-bearing components.
- Ventilation equipment and discharge paths are operating correctly and are not obstructed.
- Equipment markings and labels remain visible and legible; illegible markings shall be corrected.
- Refrigerant piping and components are installed where they are not exposed to corrosive substances, unless constructed of corrosion-resistant materials or otherwise adequately protected.

CHECKS TO ELECTRICAL DEVICES AND SEALED ELECTRICAL COMPONENTS

Repair and maintenance of electrical components shall include initial safety checks and component inspections. If a condition exists that could compromise safety, electrical power shall not be restored until the condition is corrected. If immediate correction is not possible and continued operation is necessary, an adequate temporary measure shall be implemented and reported to the equipment owner.

Initial Safety Checks Shall Include:

- Verification that capacitors are fully discharged, using methods that prevent sparking.
- Confirmation that no live electrical components or wiring are exposed during charging, recovery, or purging operations.
- Verification of continuous protective earth (ground) bonding.

Sealed electrical components shall be replaced if damaged or malfunctioning. Repair of sealed components is not permitted.

DETECTION OF FLAMMABLE REFRIGERANTS

Never use ignition sources when searching for or detecting refrigerant leaks. Halide torches or any detectors using a naked flame are strictly prohibited.

Electronic leak detectors may be used; however, when working with flammable refrigerants, sensitivity may be insufficient or require recalibration. Calibrate all detection equipment in a refrigerant-free area and ensure the detector itself is intrinsically safe and suitable for the refrigerant type.

Set leak detectors to a safe fraction of the refrigerant's Lower Flammable Limit (LFL)—no more than 25% LFL. Confirm calibration to the specific refrigerant in use.

Leak detection fluids, including bubble or fluorescent agents, are generally safe, but avoid detergents containing chlorine, as they can react with refrigerants and corrode copper piping.



OPERATION & MAINTENANCE (CONTINUED)

DETECTION OF FLAMMABLE REFRIGERANTS (CONTINUED)

If a leak is suspected:

- Extinguish all naked flames in the area.
- For leaks requiring brazing, recover all refrigerant from the system or isolate it using shut-off valves in a section of the system remote from the leak.

This ensures safe detection and handling of flammable refrigerants during maintenance or servicing.

 WARNING 
REFRIGERANT LEAK SAFETY
<p>If a refrigerant leak is suspected, immediately extinguish all open flames and eliminate potential ignition sources. For leaks requiring brazing or other hot work, recover all refrigerant from the system or isolate the affected section using shutoff valves located remotely from the work area. Refrigerant recovery and system isolation shall be performed in accordance with approved recovery and evacuation procedures.</p>

REMOVAL AND EVACUATION OF FLAMMABLE REFRIGERANTS

When opening the refrigerant circuit for repairs or maintenance, standard service procedures shall be observed. However, additional precautions are required when handling flammable refrigerants (A2L, A3, etc.) to ensure safety.

The following best practices shall be strictly followed:

- Recover the refrigerant charge in accordance with all applicable local, state, and national regulations.
- Purge the circuit with inert gas (such as oxygen-free nitrogen); this step is optional for A2L refrigerants.
- Evacuate the system if required (optional for A2L refrigerants).
- If a flame is to be used to open the circuit (e.g., for brazing), the system shall be continuously flushed with inert gas during the process.
- The circuit may then be opened by cutting or brazing.

The recovered refrigerant must be stored only in approved recovery cylinders if venting is not permitted by law. For systems containing flammable refrigerants, purge with oxygen-free nitrogen to render the system safe. This process may need to be repeated several times to ensure complete removal of refrigerant. Compressed air or oxygen shall never be used for purging refrigerant systems.

For appliances using flammable refrigerants, purging shall involve:

- Breaking the vacuum in the system with oxygen-free nitrogen.
- Pressurizing to working pressure, then venting to atmosphere.
- Pulling a vacuum again (optional for A2L refrigerants).
- Repeating this sequence until no refrigerant remains in the system.

After the final nitrogen charge, the system shall be vented down to atmospheric pressure before any work begins.

The vacuum pump outlet shall be located away from potential ignition sources, and adequate ventilation shall be provided throughout the process.

CHARGING PROCEDURES

In addition to standard refrigerant charging practices, the following safety and operational requirements shall be observed when handling flammable or A2L refrigerants:

- Prevent cross-contamination: Ensure that different refrigerants are not mixed when using charging equipment. Hoses and lines shall be kept as short as practical to minimize the volume of refrigerant they contain.
- Cylinder positioning: Refrigerant cylinders shall be positioned and secured in accordance with manufacturer instructions to prevent tipping, leakage, or damage.
- System grounding: Confirm that the refrigeration system is properly grounded (earthed) prior to introducing any refrigerant charge.
- System labeling: Upon completion of charging, the system shall be clearly labeled to identify the type and amount of refrigerant charged, if not already marked.
- Avoid overcharging: Exercise extreme care not to overfill the refrigeration system. Overcharging may result in excessive pressure, reduced performance, or potential safety hazards.

Before recharging, the system shall be pressure-tested using an appropriate inert purging gas to confirm system integrity. After charging, the system must be leak-tested before commissioning to ensure there are no leaks. A final verification leak test shall be performed prior to leaving the site.

OPERATION & MAINTENANCE (CONTINUED)

DECOMMISSIONING

Before decommissioning any equipment containing refrigerant, the technician shall be fully familiar with the unit design, refrigerant circuit, and all associated safety requirements. Decommissioning shall only be performed by qualified personnel following recognized industry and environmental best practices.

It is mandatory that all refrigerants be safely recovered and properly handled in accordance with local, national, and international regulations. Prior to initiating this procedure, obtain oil and refrigerant samples if laboratory analysis or reuse certification may be required.

Ensure that electrical power is available to operate recovery equipment before beginning.

Procedure:

A. Preparation

1. Review the unit's operation, electrical schematics, and service history to ensure complete familiarity with the system.
2. Electrically isolate the system by disconnecting and locking out all power sources.
3. Before beginning recovery operations, confirm that:
 - a) Suitable mechanical handling equipment (e.g., lifting devices or trolleys) is available for refrigerant cylinders.
 - b) All required personal protective equipment (PPE) is available and worn properly.
 - c) The recovery operation will be continuously supervised by a qualified technician.
 - d) Recovery equipment and cylinders comply with applicable design and safety standards.

B. Recovery Process

1. Pump down the refrigerant system, if possible, to minimize the amount of refrigerant in the active circuit.
2. If achieving a vacuum is not possible, install a manifold system to enable refrigerant recovery from multiple points within the circuit.
3. Place each recovery cylinder on calibrated weighing scales prior to initiating recovery to monitor fill levels accurately.
4. Start the recovery unit and operate it strictly in accordance with the manufacturer's operating instructions.
5. Do not exceed 80% of the rated liquid volume capacity of the recovery cylinder.
6. Under no circumstances shall the maximum working pressure (MWP) of the cylinder be exceeded, even temporarily.

C. Completion

1. Upon completion of refrigerant recovery:
 - a) Close all isolation valves on the system and recovery cylinders.
 - b) Clearly label cylinders with the type and quantity of refrigerant recovered.
 - c) Remove recovery equipment and filled cylinders from the site promptly.
2. Ensure all components containing refrigerant are sealed or capped to prevent leakage.
3. Recovered refrigerant shall not be reused in another refrigeration or air-conditioning system unless it has been properly reclaimed, purified, and certified in accordance with applicable environmental standards.

OPERATION & MAINTENANCE (CONTINUED)

LABELING REQUIREMENTS

Upon completion of the decommissioning process, the equipment shall be clearly labeled to indicate that it has been properly decommissioned and fully evacuated of refrigerant.

The label shall include the following information:

- A statement confirming that the unit has been decommissioned and all refrigerant removed.
- The date of decommissioning.
- The name and signature of the authorized technician performing the work.

For appliances containing flammable refrigerants, additional labeling shall be applied in accordance with applicable safety standards (e.g., ISO 5149, ASHRAE 15, and UL/CSA 60335-2-40). These labels shall:

- Clearly identify that the equipment contains or previously contained a flammable refrigerant.
- Remain visible and legible at all times during handling, storage, or disposal.
- Be affixed in a location that is readily observable on the equipment casing.

RECOVERY

When removing refrigerant from a system—whether for servicing or commissioning—it is considered best practice to ensure that all refrigerant is recovered safely and in accordance with applicable regulations.

Only approved refrigerant recovery cylinders shall be used for transferring refrigerant. Verify that a sufficient number of cylinders are available to accommodate the total system charge. All cylinders must be clearly designated and labeled for the specific refrigerant being recovered. Cylinders shall be equipped with functional pressure-relief and shut-off valves, evacuated prior to use, and, when possible, cooled before recovery begins.

All recovery equipment shall be maintained in proper working order and suitable for use with flammable refrigerants. Operating instructions for the equipment shall be readily available. A calibrated weighing scale must be on hand and operational. Recovery hoses shall be in good condition, fitted with leak-free, self-sealing couplings.

Recovered refrigerant shall be stored and processed in accordance with all applicable local and national regulations. Proper documentation, such as waste transfer notes, must be completed. Under no circumstances shall different refrigerant types be mixed within recovery units or cylinders.

When removing compressors or compressor oils, ensure that the components have been thoroughly evacuated to eliminate residual refrigerant from the lubricant. Do not use open flames or other ignition sources to heat the compressor body. Any oil removed from the system shall be handled and disposed of safely in compliance with environmental and safety requirements.

REFRIGERANT DETECTION SENSOR (RDS) INFORMATION

Refer to the appliance Installation, Operation, and Maintenance (IOM) manual for details on minimum conditioned room requirements and instructions for RDS installation, operation, and wiring.

All field-installed wiring connected to the RDS must be at least 18 AWG with a minimum insulation thickness of 1.58 mm or otherwise adequately protected from damage.

The RDS is not intended for service or repair. In the event of sensor failure, the mitigation mode will engage. The failed sensor must be replaced by removing the existing sensor and installing a new, compatible sensor.

DUCTING

For appliances connected to rooms via ductwork using A2L refrigerants:

- The room must meet the minimum area in the unit's data table or have at least 636 ft³ [18.0 m³] effective dispersal volume.
- If the room is smaller, it must have no open flames or ignition sources (e.g., gas appliances, electric heaters, or hot surfaces).
- Flame-producing devices may be used only if equipped with a flame arrestor.
- No potential ignition sources (hot surfaces >806°F [430°C] or electric switches) are allowed in the ductwork.

TROUBLESHOOTING

PROBLEM	POSSIBLE CAUSE	CHECKS & CORRECTIONS
UNIT DOES NOT RUN	Power supply off Blown Fuse Voltage supply low Thermostat	Apply power; close disconnect.
		Replace fuse or reset circuit breaker. Check for correct fuses.
		If voltage is below minimum voltage specified on unit data plate, contact lower power company. (Fault Code – Ou & 17).
		Set the fan to “ON”, the fan should run. Set thermostat to “COOL” and lowest temperature setting, the unit should run in the cooling mode (reversing valve energized). Set unit to “HEAT” and the highest temperature setting, the unit should run in the heating mode. If neither the blower nor compressor run in all three cases, the thermostat could be mis-wired or faulty. To ensure mis-wired or faulty thermostat verify 24 volts is available on the condenser section low voltage terminal strip between “R” and “C”, “Y” and “C”, and “O” and “C”. If blower does not operate, verify 24 volts between terminals “G” and “C” in the air handler. Replace the thermostat if defective.
BLOWER OPERATES BUT COMPRESSOR DOES NOT RUN	Thermostat	Check setting, calibration and wiring.
	Wiring	Check for loose or broken wires at compressor, capacitor or contractor.
	Safety Controls	Check control board fault LED for fault code.
	Compressor overload open	If the compressor is cool and the overload will not reset, replace the compressor.
	Compressor motor grounded	Internal wiring grounded to the compressor shell. Replace compressor. If compressor burnout, install new filter dryer.
	Compressor windings open	After compressor has cooled, check continuity of compressor windings. If the windings are open, replace the compressor.
UNIT OFF ON HIGH PRESSURE CONTROL FAULT CODE 12	Discharge pressure too high	In “COOLING” mode: Lack of or inadequate water flow. Entering water temperature too warm. Scaled or restricted water to refrigerant heat exchanger. In “HEATING” mode: Lack of or inadequate water flow. Entering water temperature too cold. Scaled or restricted water to refrigerant heat exchanger.
	Refrigerant charge	The unit is overcharged with refrigerant. Reclaim refrigerant, evacuate and recharge with factory recommended charge.
	High pressure switch	Check for defective or improperly calibrated high pressure switch.
UNIT OFF ON LOW PRESSURE CONTROL FAULT CODE 13	Suction Pressure too low	In “COOLING” mode: Lack of or inadequate airflow. Entering air temperature too cold. Blower inoperative, clogged filter or restriction in ductwork. In “HEATING” mode: Lack of or inadequate water flow. Entering water temperature too cold. Scaled or restricted water to refrigerant heat exchanger.
	Refrigerant charge	The unit is low on refrigerant. Check for refrigerant leak, repair, evacuate and recharge with factory recommended charge.
	Low pressure switch	Check for defective or improperly calibrated low pressure switch.
UNIT SHORT CYCLES	Unit oversized	Recalculate heating and cooling loads.
	Thermostat	Thermostat installed near a supply air register, relocate thermostat. Check heat anticipator.
	Wiring and controls	Loose connections in the wiring or a defective compressor contactor.
INSUFFICIENT COOLING OR HEATING	Unit undersized	Recalculate heating and cooling loads. If not excessive, possibly adding insulation will rectify the situation.
	Loss of conditioned air	Check for leaks in ductwork or introduction of ambient air through doors or windows.
	Airflow	Lack of adequate airflow or improper distribution of air. Replace dirty air filter.
	Refrigerant charge	Low on refrigerant charge causing inefficient operation.
	Compressor	Check for defective compressor. If discharge is too low and suction pressure is too high, compressor is not pumping properly. Replace compressor.
	Reversing valve	Defective reversing valve creating bypass of refrigerant from discharge to suction side of compressor. Discharge is too low and suction is too high. Replace reversing valve.
	Operating pressures	Compare unit operating pressures to the pressure / temperature chart for the unit.
	Refrigerant metering device	Check for possible restriction or defect. A replacement is necessary.
Moisture, non-condensables	The refrigerant system may be contaminated with moisture or non-condensables. Reclaim refrigerant, evacuate and recharge with factory recommended charge. Replace filter dryer.	

First Co. / AE-Air reserves the right to change, alter, or update data, design features, and specifications without prior notice.

SUPPORT/REFERENCE MATERIAL

REFERENCE CALCULATIONS

HEATING

$$LDB = EDB + \frac{QH}{GPM \times 500}$$

$$LWT = EAT + \frac{QA}{cfm \times 1.08}$$

COOLING

$$LDB = EDB - \frac{SC}{cfm \times 1.08}$$

$$LWT = EWT + \frac{QR}{GPM \times 500}$$

$$LC = QC - SC$$

$$SHR = \frac{SC}{QC}$$

ABBREVIATIONS & DEFINITIONS

LDB	= Leaving air temperature dry bulb °F
EDB	= Entering air temperature dry bulb °F
GPM	= Water flow rate gallons per minute
CFM	= Airflow rate cubic feet per minute
QH	= Heating capacity Btuh
QA	= Heat of absorption Btuh
SC	= Sensible cooling capacity Btuh
QR	= Heat of rejection Btuh
LC	= Latent cooling capacity Btuh
SHR	= Sensible heat ratio

COMMON CONVERSIONS

Air Flow	l/s = CFM x .47
Water Flow	l/s = GPM x .06
Static Pressure	Pa = IWC x 249
Water Pressure Drop	FOH = PSI x 2.3
Temperature	°C = (°F - 32) x 5/9
Power	kW = Btuh / 3412
Weight	oz = lb x 16
Weight	kg = lb / 2.2
EER	COP x 3.413
COP	EER / 3.413

NOTES



P.O. Box 270969 Dallas, TX 75227
www.firstco.com or www.ae-air.com

The manufacturer works to continually improve its products. It reserves the right to change design and specifications without notice.

©2026 First Co., Applied Environmental Air