

Installation, Operation, & Maintenance

IOM 6603
Rev. A 11/24

*CW(X)-HW SERIES FAN COIL UNITS

ATTENTION:

Read all instructions thoroughly and retain all manuals for future reference.

COPYRIGHT

The Manufacturer works to continually improve its products and as a result, it reserves the right to change design and specifications without notice.



WARNING



Altering the product or replacing parts with non-authorized factory parts voids all warranty or implied warranty and may result in adverse operational performance and/or a possible hazardous condition to service personnel and occupants. Company employees and/or contractors are not authorized to waive this warning.



WARNING



Only personnel trained and qualified in the installation, adjustment, servicing, maintenance, or repair of the equipment described in this manual should perform service. The manufacturer is not responsible for any injury or property damage arising from improper service or procedures. In jurisdictions where licensing is required to service this equipment, only licensed personnel should perform the service.

Improper installation, adjustment, servicing, maintenance, or repair—or attempting to perform these tasks without proper training—may result in product damage, property damage, personal injury, or death. Service personnel assume responsibility for any injury or property damage resulting from improper procedures.

TABLE OF CONTENTS

SAFETY CONSIDERATIONS	4
SAFETY INFORMATION	5
GENERAL INFORMATION	6
INSTALLATION PRECAUTIONS	7
FAN COIL UNIT	7-8
AIR DUCT DISTRIBUTIONS	9
ELECTRICAL	9
WATER PIPING	10
CONDENSATE PIPING	10
LEAK CHECK	10
REFRIGERANT CHARGING	11-12
OPERATION & MAINTENANCE	13-19
PHYSICAL DIMMENSIONS	20
NOTES	21

SAFETY CONSIDERATIONS

1. READ THE ENTIRE MANUAL BEFORE STARTING THE INSTALLATION.
2. Improper installation, adjustment, alteration, service, maintenance, or use can cause explosion, fire, electrical shock, or other conditions which may cause personal injury damage.
3. Consult a qualified licensed installer, service agency, or your distributor for information assistance. The qualified licensed installer or service agency must use factory-authorized kits or accessories when servicing this product.
4. Refer to the individual instructions packaged with kits or accessories when installing.
5. Follow all safety codes.
6. Read these instructions thoroughly and follow all warnings or cautions attached to the unit. Consult local building codes and National Electrical Code (NEC) for special requirements.





This appliance is not to be used by persons (including children) with reduced physical, sensory or mental capabilities, or lack of experience and knowledge, unless they have been given supervision or instruction.

Children should be supervised to ensure that they do not play with the appliance

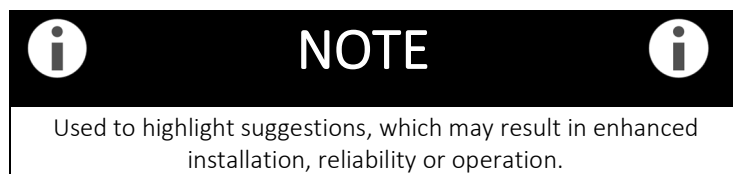
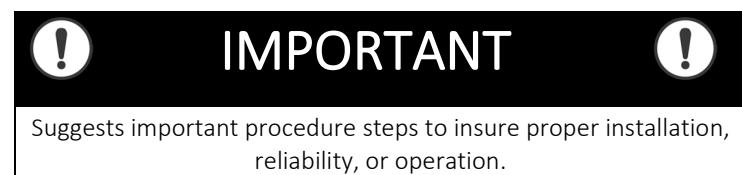
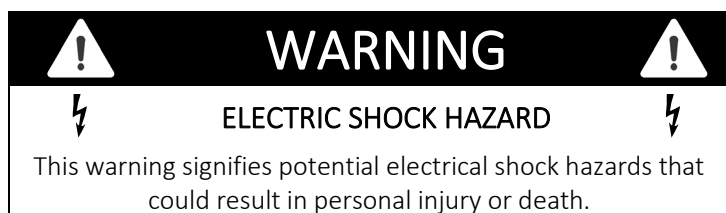
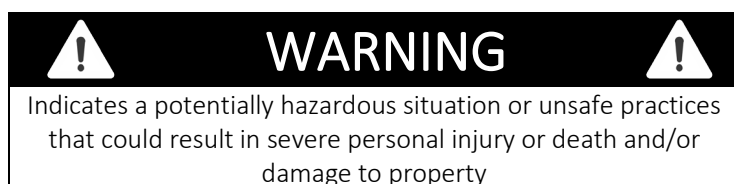

Use adequate personal protection equipment when installing and performing maintenance. After switching off and locking-out an electrical disconnect, verify a safe condition with an electrical tester. Discharge a capacitor before handling any PSC motor and wiring. Use eye protection, cut resistant gloves and sleeves to protect against metal edges and screws.

RECOGNIZE THE FOLLOWING SAFETY NOTATIONS THROUGHOUT THIS MANUAL AND POSTED ON THE EQUIPMENT:



	Service indicator; read technical manual
	Operator's manual; operating instructions
	Read the instructions
	Warning; flammable materials
	UN GHS flame symbol

SAFETY INFORMATION



 **WARNING** 

 Risk of fire. Flammable refrigerant used. To be repaired only by trained service personnel. Do not puncture refrigerant tubing.

Auxiliary devices which may be ignition sources shall not be installed in the ductwork, other than auxiliary devices listed for use with the specific appliance. See Instructions.



Dispose of refrigerant properly in accordance with federal or local regulations.

Failure to follow proper A2L refrigerant mitigation system installation instructions can result in property damage, personal injury, or death. If any fault indicators are present, please troubleshoot to prevent system malfunction.



 **WARNING** 

When a Refrigerant Leak Detection System is installed. The unit must be powered on at all times except for serving.



Installer must verify that the refrigerant sensor is properly installed and functioning or else the warranty will be voided. Failure to do so may result in fire, property damage or death.

 **WARNING** 

Work with extreme caution to minimize the risk of refrigerant ignition while installing and servicing a system containing a flammable refrigerant. Control the work environment as much as possible while potentially flammable vapors are present. Inform all persons on site about the risks of the nature of the work underway and the necessary safety precautions. Do not work in confined spaces. Test the work area for refrigerant in the air using an intrinsically safe A2L refrigerant leak detector before beginning work. Have a dry powder or CO2 fire extinguisher available. Use proper tools designed for A2L class refrigerants. While working near A2L refrigerants, use only non-sparking tools. Open flames and other ignition sources must not be present except during brazing. Brazing must only take place on evacuated and nitrogen purged refrigerant lines and components that are open to the atmosphere.

 **WARNING** 

These instructions are intended to aid qualified, licensed, service personnel in proper installation, adjustment and operation of this unit. Read these instructions thoroughly before attempting installation or operation. Failure to follow these instructions may result in improper installation, adjustment, service or maintenance possibly resulting in fire, electrical shock, property damage, personal injury or death.

 **WARNING** 



Electrical work associated with the installation of this appliance must comply with the National Electrical Code (NEC). Other local or regional electrical and building code requirements may apply.

In Canada electrical work associated with the installation of this appliance must comply with CE CSA C22.1

 **IMPORTANT** 

This fan-coil must be installed in a location which is not accessible to the general public.

This appliance is for INDOOR USE ONLY.

 **WARNING** 

 When the unit is using flammable refrigerant and is installed in a room with an area less than that outlined in section **Minimum Room Size and Mitigation Airflow**, that room shall be without continuously operating open flames or other potential ignition sources.



 **WARNING** 



 Auxiliary devices that may serve as potential ignition sources must not be installed in the ductwork. Potential ignition sources include hot surfaces exceeding 700°C and electrical switching devices.

GENERAL INFORMATION

The manufacturer does not warrant equipment subjected to abuse. Metal chips, dust, drywall tape, paint overspray, etc. can void warranties and liability for equipment failure, personal injury, and property damage. The manufacturer does not warrant equipment installed in violation of any code requirement.

*CW(X)-HW models are wall / closet hydronic air handlers. A high efficiency constant torque ECM blower motor is available.

 WARNING 	
<ul style="list-style-type: none"> • Always wear eye protection when working on equipment • Before servicing unit, always turn off all power to unit. There may be more than one disconnect switch. Electrical shock can cause personal injury or death. • When fan coil is operating, some components are operating at high speeds. Personal injury can result from touching these items with any object. • All electrical and service access panels must be secured in their proper place before operating equipment • Clear surrounding areas of all tools, equipment and debris before operating unit. 	

 WARNING 	
<p>Unit must not be operated in any mode during building construction due to excessive airborne dust and debris. Also, the unit must never run under any circumstances without an air filter in place.</p>	



These instructions give information for installation of the fan coil units only. For other related equipment, refer to the manufacturer's instructions.

Material in this shipment has been inspected at the factory and released to the transportation agency in good condition. When received, a visual inspection of all cartons should be made immediately. Any evidence of rough handling or apparent damage should be noted on the delivery receipt and the material inspected in the presence of the carrier's representative. If damage is found, a claim should be filed against the carrier immediately.

All models are designed for indoor installation only. The installation of this unit, field wiring, duct system, and other related equipment must conform to the requirements the National Electric Code, ANSI/NFPA No. 70 (latest edition) in the United States, as well as any state laws and local codes. Local authorities having jurisdiction should be consulted before installation is made.

Such applicable regulations take precedence over the general instructions contained in this manual. Extreme caution must be taken that no internal damage will result if screws or holes are drilled into the cabinet.

INSTALLATION PRECAUTIONS

WARNING

Some units are very heavy. Use two or more people when moving and installing these units. Failure to do so could result in personal injury or death. Contact with metal edges and corners while applying excessive force can result in personal injury. Use gloves when handling equipment. Use caution during installation or while servicing equipment.

Installation of this fan coil should be performed only by a licensed contractor to ensure proper installation and the safety of the installer. Observe the following precautions for typical installations:

- Always use proper tools and equipment.
- No wiring or other work should be attempted without first ensuring fan coil is completely disconnected from the power source and locked out. Always verify that a good permanent, uninterrupted ground connection exists prior to energizing any power sources.
- Always review the nameplate and wiring diagram on each unit for proper voltage and control configurations. This information is determined from the components and wiring of the unit and may vary from unit to unit.
- When soldering or brazing to the unit, have a fire extinguisher readily available. When soldering close to water valves or other components, heat shields or wet rags are required to prevent damage
- When the fan coil unit is in operation components are rotating at high speeds.
- Units must be installed level or angled toward the drain nipple to ensure proper drainage and operation.
- Check unit prior to operation to ensure that the condensate water will drain toward the drain connection. An overflow drain or an auxiliary drain pan under the fan coil may be required as a back up to a clogged primary drain.
- Be sure that the drain pan is free from foreign material prior to start up

- Check filter media installation to ensure that it is installed correctly.
- Use the directional arrows or other information on the filter to determine the proper flow direction.
- Ensure air distribution system does not exceed the external static rating of the unit.

Select a location that will provide adequate space to mount the unit and accommodate ducting. The recommended clearance for service is 24". Units with or without electric heat may be installed with 0" clearance to combustibles. Always check the unit rating plate for clearance and other information before mounting unit. Refer to dimensional data in FIGURE #* for units and enclosures to determine space required for mounting.

Insulation is installed in indoor equipment to provide a barrier between outside air conditions surrounding the unit and the varying conditions inside the unit. If the insulating barrier is damaged, the surrounding ambient air will affect the inside surface temperature of the cabinet. The temperature / humidity difference between the inside and outside can cause condensation to form on the inside and outside of the cabinet which leads to sheet metal corrosion and subsequently component failure.

Damaged insulation must be repaired or replaced before the unit is placed back into operation. Insulation loses its insulation value when wet, damaged, separated or torn.

FAN COIL UNIT

The installer must adhere strictly to all local and national code requirements pertaining to the installation of this equipment. All units are designed for indoor use only, and are agency listed for installation with zero clearance to combustible materials. This includes the fan coil cabinet, discharge plenum and connecting ducts. These units are designed to be installed vertically in the up flow position by the following mounting means:

HUNG IN CLOSET WALL

Air handler may be wall mounted using mounting kit, 90PK3 or 90PK31. Bracket and screws are provided for the air handler.

It is recommended that sound isolating material be installed to prevent any undesired transfer of sound.

FAN COIL UNIT CONTINUED

RECESSED IN A WALL

Installation of the fan coil recessed into a partition wall with its recommended framing is shown in figure 1. This application requires the optional louvered wall panel which must be ordered separately. Wall panel with frame is secured to the studs by screws or nails after the dry wall has been installed. Refer to figure 1 and figure 2.

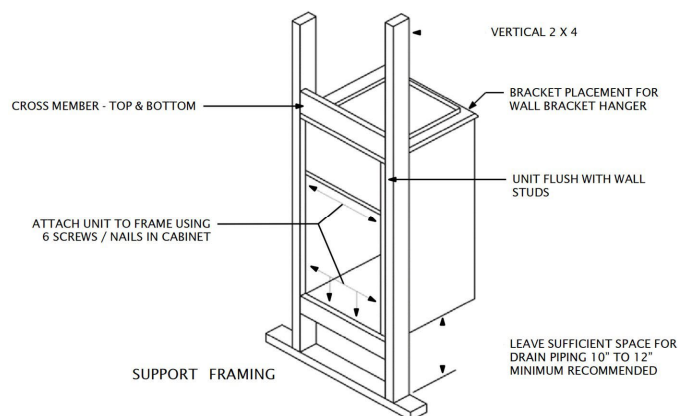

Figure 1 Recessed Wall Mounting

NOTE

The front face of the unit must be installed flush with the dry wall.

CLOSET PLATFORM FRONT RETURN

Fan coil may be set on a platform and secured by screws or nails. Sufficient space for drain piping is required under the platform.

In addition, sufficient clearance must be provided at the front of the fan coil to allow access to electrical controls and removal of the motor/ blower assembly for servicing. This clearance distance should be approximately the same as the depth dimension of the fan coil unit

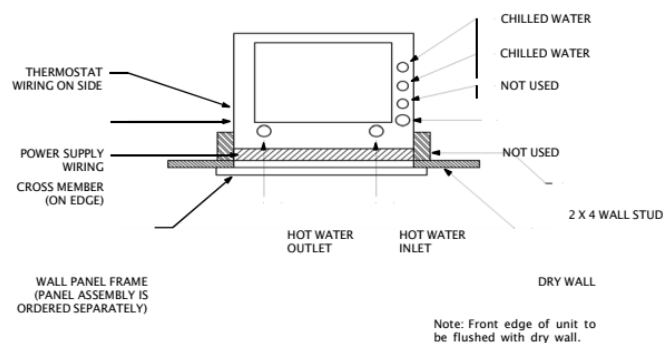

Figure 2 Installed Unit Top View

NOTE

A field-fabricated secondary drain pan, with a drain pipe routed to the outside of the building, may be required when the fan coil unit is above a finished living space or in any area that may be damaged by water overflow from the main drain pan.

NOTE

If a condensate overflow shut off switch, that is designed to be installed in the drain line, is used in place of a secondary drain line then place it in the primary drain line between the fan coil and the P-trap.

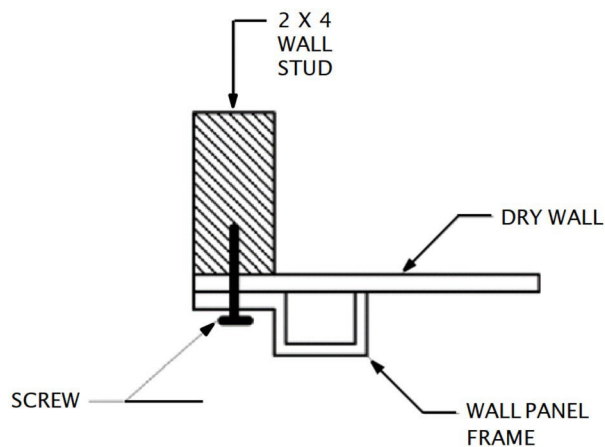

Figure 3 Detail of Wall Panel Frame Installation





AIR DISTRIBUTION DUCTS

All duct work must be installed in accordance with National Fire Protection Association Codes 90A and 90B. Ducts should be adequately insulated to prevent condensation during the cooling cycle and to minimize heat loss during the heating cycle. All return air must be filtered to prevent dirt buildup on the coil surface. If there is no ducted return, applicable installation codes may limit the unit to installation only in a single story residence. In many cases it is acceptable to use ducting of the same size as the fan coil connections. However, unique arrangements or long duct runs must be confirmed by a local professional. The manufacturer will not be responsible for misapplied equipment.

	CAUTION	
The duct system including filter, registers, and louvers must not exceed the external static pressure listed on the unit rating plate.		



Supply and return duct system must be adequately sized to meet the system's air requirements and static pressure capabilities. The duct system should be insulated with a minimum of 1-inch insulation with a vapor barrier in conditioned areas or 2-inches, minimum in unconditioned areas.

ELECTRICAL

	WARNING	
	ELECTRIC SHOCK HAZARD	
Disconnect all power supplies before servicing; lock out/tag out to prevent accidental electrical shock. Note: there may be multiple power sources.		
<ul style="list-style-type: none"> • Use copper conductors only. • Install all parts and panels before operating. • Failure to follow these warnings can result in injury or death. 		





Field installed wiring supplying power to this unit and / or electric heaters must include a disconnect device at the unit.

All wiring must comply with local and national code requirements. Units are provided with wiring diagrams and nameplate data to provide information required for necessary field wiring. Refer to figure x for points of entry of the wiring into the cabinet.

	WARNING	
Electrical work associated with the installation of this appliance must comply with the National Electrical Code (NEC). Other local or regional electrical and building code requirements may apply.		
In Canada electrical work associated with the installation of this appliance must comply with CSA CEC22.1		





These units are provided with a Class 2 transformer for 24-volt control circuits. Should any add-on equipment also have a Class 2 transformer furnished, care must be taken to prevent interconnecting outputs of the two transformers by using a thermostat with isolating contacts.

Heater kits are approved only for installation in "0 KW" models. Field installed heater kits are not approved for installation in units built with factory installed heaters.

	WARNING	
	ELECTRIC SHOCK HAZARD	
Transformers are multi voltage, it is crucial to refer to unit wiring diagram, transformers wiring diagram as well as unit voltage to ensure proper connections and operation safety.		

ELECTRICAL OVER CURRENT PROTECTION

HACR type breakers are recommended. Other overcurrent protection devices that comply with all applicable codes are acceptable

	WARNING	
	ELECTRIC SHOCK HAZARD	
Means of disconnection must be incorporated in the fixed wiring in accordance with the wiring rules.		

WATER PIPING

These units employ a hydronic coil designed for use with hot and chilled water.

- All piping must be adequately sized to meet the design water flow requirements as specified for the specific installation.
- The piping connections on the equipment are not necessarily indicative of the proper supply and return line sizes. Piping design should be kept as simple as possible
- Piping must be installed in accordance with all applicable codes.
- Prior to connecting to the fan coil, all external piping must be purged of debris
- All chilled water piping must be insulated to prevent property damage from condensation. It is also recommended that all piping be insulated to prevent freezing when piping is located in an unconditioned space.



CAUTION



When connecting piping to fan coil units, do not bend or reposition the coil header tubing for alignment purposes. This could cause a tubing fracture resulting in a water leak when pressure is applied to the system.



NOTE



Coil freeze protection is recommended for applications where the fan coil is located in low ambient temperature locations (attics, crawl spaces) or within structures that may be unoccupied during freezing conditions. Consult the factory for additional information.



NOTE



Many valve packages will not physically allow all components to fit over an auxiliary drain pan. It is the installers responsibility to insulate all piping to ensure adequate condensation prevention

CONDENSATE PIPING

Condensate drain lines must be installed with adequate slope away from the unit to assure positive drainage. Since the drain pan is located on the suction side of the blower, a negative pressure exists at the drain pan. Fan coil units require a minimum trap of 1-1/2 inches provided in the drain line to assure proper drainage.



WARNING



On units with plastic drain pans the drain connections must be made hand tight only.

A condensate switch may be installed in lieu of an auxiliary drain line if permitted by local code.

SOUND QUALITY

These fan coil units are designed for quiet operation; however, all air conditioning equipment will transfer some amount of noise to the conditioned space. This should be taken into consideration when planning the location of the equipment.

LEAK CHECK

After pipe installation perform a leak check to ensure that no leakage of refrigerants will occur. Use nitrogen to pressure test at a minimum of 200 psig. Pressure must not decrease within 1 hour. Care must be taken to not use any leak detectors which may cause corrosion on the copper tubing.

Evacuate the suction and liquid lines at the outdoor unit service valves to 500 microns. Isolate the vacuum pump from the piping. The vacuum must not exceed 1500 microns in 10 minutes.

REFRIGERANT CHARGING

WARNING

FIRE OR EXPLOSION HAZARD

Failure to following this warning could result in personal injury, death and/or property damage.

Do not use flames or any potential ignition sources to leak check refrigerant tubing or components.

IMPORTANT

Any metering device installed in the refrigerant circuit must be compatible with the refrigerant used.

Use adequate personal protection equipment when handling refrigerant including, but not limited to eye and hand protection. Consult the outdoor unit manufacturer's instructions for refrigerant charging and consider all pertinent factors when determining the method of charging and the amount of refrigerant required; indoor and outdoor temperatures and humidity, the factory charge amount of the outdoor unit, the length and diameter of tubing between the indoor and outdoor units, the type of metering device installed.

WARNING

- Explosion risk, recover refrigerant only in a cylinder designed and intended for this purpose
- Do not use a damaged cylinder
- Do not apply flame or excessive heat to a refrigerant cylinder
- Do not fill a refrigerant cylinder to more than 80% of its capacity
- Do not use a refrigerant cylinder for anything other than its designed and intended purpose
- Do not use an expired refrigerant cylinder
- Use recovery equipment designed to handle the refrigerant being recovered
- Earth-ground refrigerant cylinders before using

WARNING

IMPROPER HANDLING OF REFRIGERANTS CAN CAUSE INJURY, EXPLOSION AND DEATH

- It is illegal to release refrigerant into the atmosphere. Refrigerant released into an enclosed space will displace oxygen causing unconsciousness and death.
- If an indoor refrigerant leak is suspected, thoroughly ventilate the area before beginning any work
- DO NOT purge or allow refrigerant to be released into an interior space
- Contact with liquid refrigerant can cause frostbite and blindness. Avoid skin contact with liquid refrigerant, wear goggles and gloves when working with refrigerants. Seek medical help immediately if any refrigerant contact with skin or eyes occurs
- Never burn refrigerant as highly toxic gas will be produced
- Only EPA certified technicians should handle refrigerants.
- In Canada technicians must be ODP / ODS certified to handle refrigerants
- Follow all EPA regulations

WARNING

It is illegal to discharge refrigerant into the atmosphere. Use proper reclaiming methods and equipment when installing or servicing this unit. A QUALIFIED service agency should perform this service.

REFRIGERANT CHARGING CONTINUED

Follow the outdoor unit manufacturer's instructions for adding refrigerant to a partially charged system.

FLAMMABLE REFRIGERANT LEAK DETECTION

Under no circumstances should potential sources of ignition be used for detecting refrigerant leaks. Devices such as halide torches (or other detectors using a naked flame) are strictly prohibited. Acceptable methods for refrigerant leak detection include:

- **Electronic Leak Detectors:** These may be used to detect refrigerant leaks; however, for flammable refrigerants, ensure the sensitivity is adequate and the equipment is recalibrated as necessary. Calibration must occur in a refrigerant-free area. The detector must not pose an ignition risk and should be specifically suited for the refrigerant used. Set the detection equipment to a percentage of the refrigerant's Lower Flammability Limit (LFL), with a maximum setting of 25%. Ensure calibration corresponds to the refrigerant employed.
- **Leak Detection Fluids:** Fluids such as the bubble method or fluorescent agents are suitable. Avoid detergents containing chlorine, as these may react with the refrigerant and corrode copper pipework.

Important Note: If a refrigerant leak is suspected, all open flames must be extinguished. For leaks requiring brazing, recover all refrigerant from the system or isolate it using shut-off valves in a remote part of the system. Removal of refrigerant must follow the removal and evacuation procedures.

REFRIGERANT CHARGING INSTRUCTIONS

When charging the system in cooling mode, ensure the outdoor temperature is 60°F or higher. Operate the system for a minimum of 15 minutes between adjustments to allow the pressures to stabilize. Systems equipped with micro-channel outdoor coils require small adjustments of 1 ounce or less, as they are highly sensitive to refrigerant charge.

TXV Charging

1. Refer to the instructions provided with the outdoor unit.
2. Alternatively, for AC units, charge to achieve 12°F sub-cooling. For heat pump units, charge to 10°F sub-cooling.
3. If the system is equipped with an adjustable valve, adjust to achieve 10°F superheat.

Fixed Orifice Charging

1. Use the superheat value recommended in the outdoor unit instructions for A1 (R-410) and A2L (R-454B & R-32) refrigerants.
2. Heat pump units initially charged in cooling mode may require final charge adjustments in heating mode, if necessary. For units requiring charging in heating mode, refer to the outdoor unit instructions.

If the system is undercharged after the initial charge, add refrigerant until the sight glass is clear and the recommended pressures, temperatures, sub-cooling, and superheat are achieved. If the system is overcharged, recover refrigerant until these values are within recommended limits.

OPERATION & MAINTENANCE

WARNING

FIRE OR EXPLOSION HAZARD

Failure to following this warning could result in personal injury, death and/or property damage. Do not attempt any sealed system repair without first recovering the entire refrigerant charge. Refrigerant and oil mixture could ignite in the presence of a brazing torch flame. Completely recover the refrigerant charge using both the high and low sides of the system and purge the sealed system with nitrogen before brazing any component or tubing.

WARNING

FIRE OR EXPLOSION HAZARD

Do not mix refrigerant with air for leak testing or other purposes.

WARNING

ELECTRIC SHOCK HAZARD

Electrically ground the fan coil. Connect the ground wire to the terminal marked with the ground symbol, . Failure to properly ground the unit could result in injury or death. Always disconnect power before servicing and verify power is off to prevent accidental shock.

CAUTION

Devices such as fan switches or thermostats provided for field installation must be wired according to the supplied wiring diagram. Failure to do so could result in damage to components and void the warranty.

PRE-START CHECK

Before starting the unit:

1. Ensure supply voltage matches the nameplate data.
2. Verify the unit is properly grounded.
3. Check blower wheel set screws for tightness and ensure blower wheels rotate freely and quietly.
4. Ensure the fan coil is securely installed and sloped toward the drain line.
5. Verify the condensate line is properly sized, run, trapped, pitched, and tested.
6. Ensure a clean filter is installed and access panels are secured.

7. Check that refrigerant coil connections and piping are leak-free and properly insulated.
8. Seal any knockouts, penetrations, or exposed holes to maintain low air leakage.

WARNING

ELECTRIC SHOCK HAZARD

Disconnect all power supplies before servicing. Lockout/tagout to prevent accidental shock. Ensure all personal protective equipment is worn when servicing or maintaining the unit.

START-UP AND MAINTENANCE

Before start-up, perform the following checks:

- Clean all components of debris to prevent operational issues.
- Ensure all access panels and filters are properly installed.
- Verify unit cleanliness and secure all rotating components.

MAINTAINING LOW LEAKAGE RATE

During installation, ensure that all grommets and gaskets remain intact on all surfaces as shipped with the unit. Any knockouts, penetrations, and holes that were exposed must be sealed to prevent air leakage. All access panels and covers must be flush with each other and the cabinet. With these requirements satisfied, the unit will maintain and achieve less than 2% air flow leakage when tested in accordance with ASHRAE Standard 193.

FAN

Inspect and clean the fan annually in conjunction with motor and bearing maintenance. Keep wheels clean to avoid imbalance and vibration.

MOTOR

Check motor connections for security and compliance with wiring diagrams. For ECM motors, ensure power is disconnected before servicing, as line voltage is always present.

OPERATION & MAINTENANCE CONTINUED

FILTER

Replace or clean the air filter every 30 days or more frequently under severe conditions. Use the same type as originally furnished.

COIL

Clean dust or contaminants from heat transfer surfaces using one of the following methods:

- Low-pressure compressed air.
- Flushing with water (use a detergent for greasy surfaces).

DRAIN PIPING

Ensure the drain is:

- Properly connected and sloped away from the unit (1/8 inch per foot minimum).
- Checked before summer operation and periodically during operation.

REFRIGERANT DETECTION SENSOR (RDS) INFORMATION

For equipment utilizing A2L refrigerants, a Refrigerant Detection System (RDS) is installed on this unit to detect any A2L refrigerant leakage in the coil and internal refrigerant containing components and will take action to mitigate any risk of ignition / fire.

Refer to the appliance IOM for information regarding the minimum conditioned room requirements, and instructions for the RDS operation, installation, and wiring. Any field installed wiring connected to the RDS must be at least 18AWG and have minimum insulation thickness of 1.58mm or be protected from damage.

The RDS is not intended for service or repair. In the event of a sensor failure, the mitigation mode will engage and the sensor shall be replaced by removing the sensor and replacing it with a new sensor.

False ceilings or drop ceilings may be used as a return air plenum if a refrigerant detection system is provided in the appliance and any external connections are also provided with a sensor immediately below the return air plenum duct joint.

QUALIFICATION OF WORKERS

Service shall only be performed by qualified technicians, certified by national training organizations or manufacturers that are accredited to teach the relevant national competency standards that may be set in legislation. Competence to properly service the appliance should be documented by a certificate.

CHECKS TO THE WORK AREA

Prior to beginning work on the appliance, safety checks are necessary to ensure that the risk of ignition of released gasses is minimized. Work shall be undertaken under a controlled procedure so as to minimize the risk of a flammable gas or vapor being present while the work is being performed.

All maintenance staff and others working in the local area shall be instructed on the nature of work being carried out. Work in confined spaces shall be avoided.

CHECKING FOR PRESENCE OF REFRIGERANT

The area shall be checked with an appropriate refrigerant detector prior to and during work, to ensure the technician is aware of potentially toxic or flammable atmospheres. Ensure that the leak detection equipment being used is suitable for use with all applicable refrigerants, i.e. non-sparking, adequately sealed or intrinsically safe.

If any hot work is to be conducted on the refrigerating equipment or any associated parts, appropriate fire extinguishing equipment shall be available to hand. Have a dry powder or CO2 fire extinguisher adjacent to the charging area.

No person carrying out work in relation to a REFRIGERATING SYSTEM which involves exposing any such a pipe work shall use any sources of ignition in manner that it may lead to the risk of fire or explosion.

All possible ignition sources, including cigarette smoking, should be kept sufficiently far away from the site of installation, repairing, removing and disposal, during which refrigerant can possibly be released to the surrounding space. Prior to work taking place, the area around the equipment is to be surveyed to make sure that there are no flammable hazards or ignition risks. "NO SMOKING" signs shall be displayed.

OPERATION & MAINTENANCE CONTINUED

VENTILATED AREA

Ensure that the area is in the open or that it is adequately ventilated before breaking into the system or conducting any hot work. A degree of ventilation shall continue during the period that the work is carried out. The ventilation should safely disperse any released refrigerant and preferably expel it externally into the atmosphere.

CHECKS TO THE REFRIGERATING EQUIPMENT

Where electrical components are being changed, they shall be fit for the purpose and to the correct specification. At all times the manufacturer's maintenance and service guidelines shall be followed. If in doubt, consult the manufacturer's technical department for assistance.

The following checks shall be applied to installations using FLAMMABLE REFRIGERANTS:

- The actual REFRIGERANT CHARGE is in accordance with the room size within which the refrigerant containing parts are installed;
- The ventilation machinery and outlets are operating adequately and are not obstructed;
- Marking to the equipment continues to be visible and legible. Markings and signs that are illegible shall be corrected;
- Refrigerating pipe or components are installed in a position where they are unlikely to be exposed to any substance which may corrode refrigerant containing components, unless the components are constructed of materials which are inherently resistant to being corroded or are suitably protected against being so corroded.

CHECKS TO ELECTRICAL DEVICES AND SEALED ELECTRICAL COMPONENTS

Repair and maintenance to electrical components shall include initial safety checks and component inspection procedures. If a fault exists that could compromise safety, then no electrical supply shall be connected to the circuit until it is satisfactorily dealt with. If the fault cannot be corrected immediately but it is necessary to continue operation, an adequate temporary solution shall be used. This shall be reported to the owner of the equipment so all parties are advised.

Initial Safety Checks shall include:

- That capacitors are discharged: this shall be done in a safe manner to avoid possibility of sparking;
- That no live electrical components and wiring are exposed while charging, recovering or purging the system;
- That there is continuity of earth bonding.

Sealed electrical components shall be replaced in the event of damage or malfunction.

FLAMMABLE REFRIGERANT LEAK DETECTION

Under no circumstances should potential sources of ignition be used for detecting refrigerant leaks. Devices such as halide torches (or other detectors using a naked flame) are strictly prohibited. Acceptable methods for refrigerant leak detection include:

- **Electronic Leak Detectors:** These may be used to detect refrigerant leaks; however, for flammable refrigerants, ensure the sensitivity is adequate and the equipment is recalibrated as necessary. Calibration must occur in a refrigerant-free area. The detector must not pose an ignition risk and should be specifically suited for the refrigerant used. Set the detection equipment to a percentage of the refrigerant's Lower Flammability Limit (LFL), with a maximum setting of 25%. Ensure calibration corresponds to the refrigerant employed.
- **Leak Detection Fluids:** Fluids such as the bubble method or fluorescent agents are suitable. Avoid detergents containing chlorine, as these may react with the refrigerant and corrode copper pipework.

Important Note: If a refrigerant leak is suspected, all open flames must be extinguished. For leaks requiring brazing, recover all refrigerant from the system or isolate it using shut-off valves in a remote part of the system. Removal of refrigerant must follow the removal and evacuation procedures.

OPERATION & MAINTENANCE CONTINUED

REMOVAL AND EVACUATION OF FLAMMABLE

REFRIGERANTS

When breaking into the refrigerant circuit to make repairs – or for any other purpose – conventional procedures shall be used. However, for FLAMMABLE REFRIGERANTS it is important that best practice is followed since flammability is a consideration. The following procedure shall be adhered to:

- Remove refrigerant charge following local and national regulations
- Purge the circuit with inert gas (optional for A2L);
- Evacuate (optional for A2L)
- If using flame to open circuit, continuously flush system with an inert gas
- Open the circuit by cutting or brazing.

The refrigerant charge shall be recovered into the correct recovery cylinders if venting is not allowed by local and national codes. For appliances containing flammable refrigerants, the system shall be purged with oxygen-free nitrogen to render the appliance safe for flammable refrigerants. This process might need to be repeated several times. Compressed air or oxygen shall not be used for purging refrigerant systems.

For appliances containing flammable refrigerants, refrigerant purging shall be achieved by breaking the vacuum in the system with oxygen-free nitrogen and continuing until the working pressure is achieved, then venting to the atmosphere, and finally pulling down to a vacuum (optional for A2L). This process shall be repeated until no refrigerant is within the system (optional for A2L). When the final oxygen-free nitrogen charge is used, the system shall be vented down to atmospheric pressure to enable work to take place.

The outlet for the vacuum pump shall not be close to any potential ignition sources, and ventilation shall be available.

CHARGING PROCEDURES

In addition to conventional charging procedures, the following requirements shall be followed.

- Ensure that contamination of different refrigerants does not occur when using charging equipment. Hoses or lines shall be as short as possible to minimize the amount of refrigerant contained in them.
- Cylinders shall be kept in an appropriate position according to the instructions.
- Ensure that the REFRIGERATING SYSTEM is earthed prior to charging the system with refrigerant.
- Label the system when charging is complete (if not already).
- Extreme care shall be taken not to overfill the REFRIGERATING SYSTEM.

Prior to recharging the system, it shall be pressure-tested with the appropriate purging gas. The system shall be leak-tested on completion of charging but prior to commissioning. A follow up leak test shall be carried out prior to leaving the site.

DECOMMISSIONING

Before carrying out this procedure, it is essential that the technician is completely familiar with the equipment and all its detail. It is recommended good practice that all refrigerants are recovered safely. Prior to the task being carried out, an oil and refrigerant sample shall be taken in case analysis is required prior to re-use of recovered refrigerant. It is essential that electrical power is available before the task is commenced.

- A. Become familiar with the equipment and its operation.
- B. Isolate system electrically.
- C. Before attempting the procedure, ensure that:
 - a. mechanical handling equipment is available, if required, for handling refrigerant cylinders;
 - b. all personal protective equipment is available and being used correctly;
 - c. the recovery process is supervised at all times by a competent person;
 - d. recovery equipment and cylinders conform to the appropriate standards.

OPERATION & MAINTENANCE CONTINUED

- D. Pump down refrigerant system, if possible.
- E. If a vacuum is not possible, make a manifold so that refrigerant can be removed from various parts of the system.
- F. Make sure that cylinder is situated on the scales before recovery takes place.
- G. Start the recovery machine and operate in accordance with instructions.
- H. Do not overfill cylinders (no more than 80 % volume liquid charge).
- I. Do not exceed the maximum working pressure of the cylinder, even temporarily.
- J. When the cylinders have been filled correctly and the process completed, make sure that the cylinders and the equipment are removed from site promptly and all isolation valves on the equipment are closed off.
- K. Recovered refrigerant shall not be charged into another REFRIGERATING SYSTEM unless it has been cleaned and checked.

LABELING

Equipment shall be labelled stating that it has been de-commissioned and emptied of refrigerant. The label shall be dated and signed. For appliances containing FLAMMABLE REFRIGERANTS, ensure that there are labels on the equipment stating that the equipment contains FLAMMABLE REFRIGERANT.

RECOVERY

When removing refrigerant from a system, either for servicing order commissioning, it is recommended good practice that all refrigerants are removed safely.

When transferring refrigerant into cylinders, ensure that only appropriate refrigerant recovery cylinders are employed. Ensure that the correct number of cylinders for holding the total system charge is available. All cylinders to be used are designated for the recovered refrigerant and labelled for that refrigerant (i.e. special cylinders for the recovery of refrigerant). Cylinders shall be complete with pressure-relief valve and associated shut-off valves in good working order. Empty recovery cylinders are evacuated and, if possible, cooled before recovery occurs.

The recovery equipment shall be in good working order with a set of instructions concerning the equipment that is at hand and shall be suitable for the recovery of the flammable refrigerant. If in doubt, the manufacturer should be consulted. In addition, a set of calibrated weighing scales shall be available and in good working order. Hoses shall be complete with leak-free disconnect couplings and in good condition.

The recovered refrigerant shall be processed according to local Legislation in the correct recovery cylinder, and the relevant waste transfer note arranged. Do not mix refrigerants in recovery units and especially not in cylinders.

If compressors or compressor oils are to be removed, ensure that they have been evacuated to an acceptable level to make certain that flammable refrigerant does not remain within the lubricant. The compressor body shall not be heated by an open flame or other ignition sources to accelerate this process. When oil is drained from a system, it shall be carried out safely

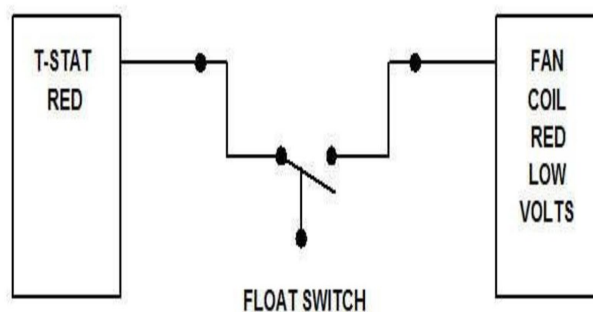

Figure 4 Float Switch

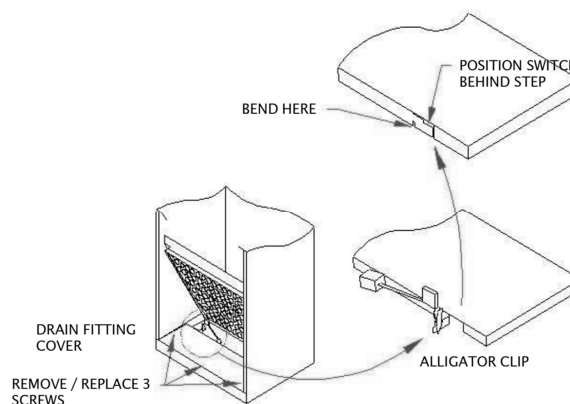

Figure 5 Auxiliary Float Switch Installation

OPERATION & MAINTENANCE CONTINUED

Status Light Table for Refrigerant Detection System (RDS)		
Status Light	State / Condition	System Response
Green Blinking	Normal Operation	<ul style="list-style-type: none"> - The system is actively monitoring refrigerant levels. - No refrigerant detected above the activation threshold. - Outdoor unit compressor and indoor blower operate normally.
Red Continuous	Refrigerant Leak Detected	<ul style="list-style-type: none"> - Refrigerant concentration exceeds the activation threshold. - The outdoor unit compressor (Y) is turned off to prevent further circulation of refrigerant. - The indoor blower is turned on to recirculate air and mitigate the refrigerant concentration.
Red Blinking	Fault Detected	<ul style="list-style-type: none"> - A fault in the refrigerant detection system (e.g., calibration issue, end-of-life) has been detected. - The outdoor unit compressor (Y) and indoor blower mitigation mode are deactivated for safety. - System requires inspection or replacement.
No Light	System Off or Malfunction	<ul style="list-style-type: none"> - The system is not operational. - Check the power supply and all system connections.
Amber Blinking	System Initializing	<ul style="list-style-type: none"> - The system is warming up after power-up. - The outdoor unit compressor (Y) and indoor blower mitigation mode remain inactive during this phase. - Transitions to green blinking when monitoring begins.

A2L SENSING AND MITIGATION

Air handler units that can be charged with over 4lbs (1.81kg) of R454B or R32 refrigerant are shipped with a factory installed refrigerant leak detector attached near the bottom of the evaporator coil. In the event that a refrigerant leak is detected, the controls will disable the compressor operation, and energize the evaporator fan to disperse the leaked refrigerant. The unit will operate in this mitigation state until the sensor no longer detects a refrigerant leak, for a minimum time of 5 minutes. Once the mitigation period has ended, the unit will return to its normal operation based on the current thermostat inputs. An LED status light is provided with the sensor for diagnostic purposes, the description of the LED status light signals can be found in the following table.

OPERATION & MAINTENANCE CONTINUED

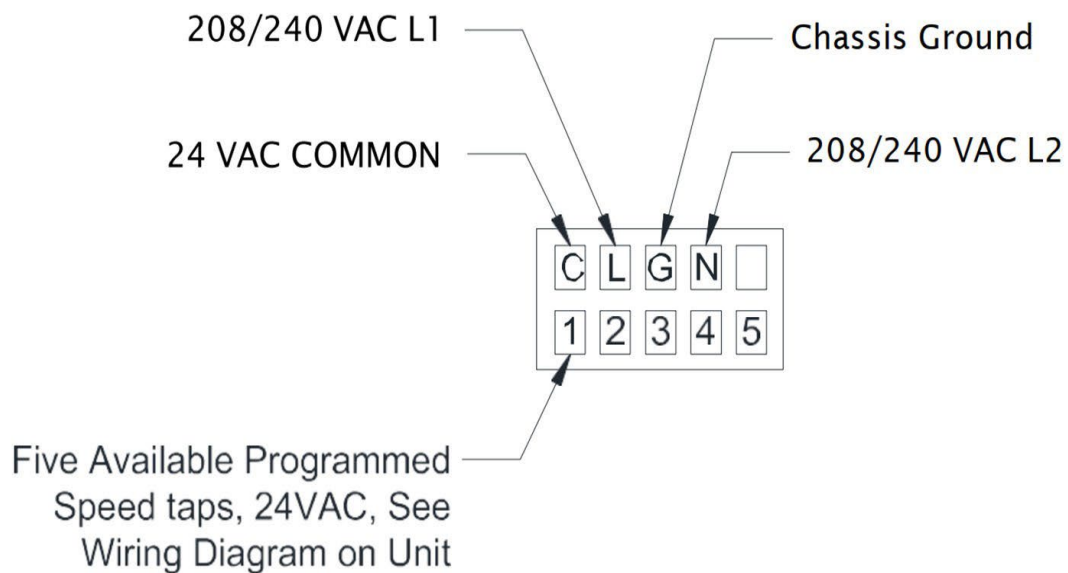
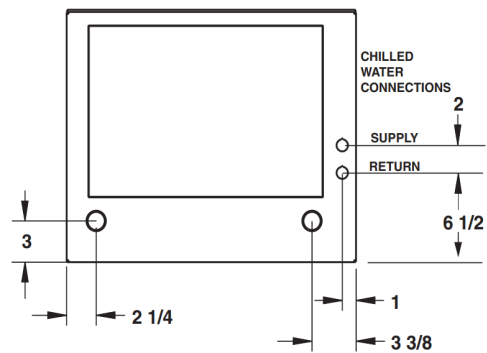

Figure 6 Brushless Dc Motor Connections

PHYSICAL DIMMENSIONS



Top Panel View

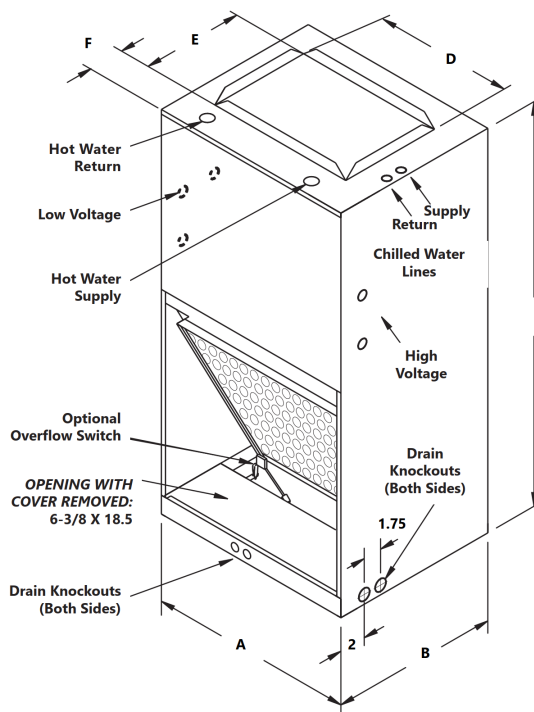

Figure 7 Unit Physical Dimensions

PHYSICAL DIMENSIONS								
UNIT MODEL	A (cm)	B (cm)	C (cm)	D (cm)	E (cm)	F (cm)	FILTER SIZE (cm)	CW & HW COIL CONNECTIONS (cm)
4 / 8CW(X)-HW	22-1/8" (56.2)	18-1/8" (46)	43" (109.2)	18" (45.7)	12-1/2" (31.75)	4-3/4" (12)	18" X 18" X 1" (45.7 X 45.7 X 2.54)	5/8" OD (1.5875)
10CW(X)-HW	22-1/8" (56.2)	18-1/8" (46)	43" (109.2)	18" (45.7)	12-1/2" (31.75)	4-3/4" (12)	18" X 20" X 1" (45.7 X 50.8 X 2.54)	5/8" OD (1.5875)
12CW(X)-HW	22-1/8" (56.2)	21-1/8" (53.66)	43" (109.2)	18" (45.7)	15-1/2" (39.4)	4-3/4" (12)	18" X 20" X 1" (45.7 X 50.8 X 2.54)	5/8" OD (1.5875)

TABLE 1

NOTES



P.O. Box 270969 Dallas, TX 75227
www.firstco.com or www.ae-air.com

The manufacturer works to continually improve its products. It reserves the right to change design and specifications without notice.

©2022 First Co., Applied Environmental Air