

Installation, Operation, & Maintenance Manual

IOM 8001
Rev. G 8/22

WSV6 009-072 Vertical Series Water Source Heat Pump

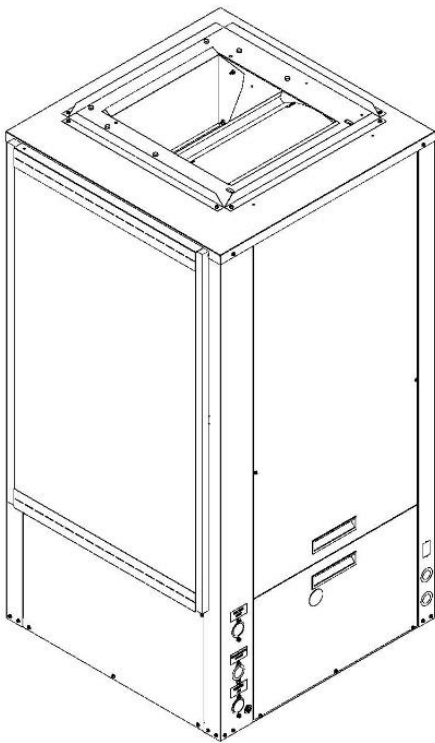

HydroTech™
R-410A Water Source Heat Pump



COPYRIGHT

First Co. / AE-Air works to continuously improve its products and as a result, it reserves the right to change design and specifications without notice.

The warranty may be void unless the Startup & Performance Checklist is completed and returned to the warrantor. If the HVAC unit is not installed properly, the warranty will be void, as the manufacturer cannot be held accountable for problems that stem from improper installation.

©2022 First Co. / AE-Air, 8273 Moberly Lane, Dallas, TX 75227

*****WARNING TO INSTALLER, SERVICE PERSONNEL AND OWNER*****

Altering the product or replacing parts with non-authorized factory parts voids all warranty or implied warranty and may result in adverse operational performance and/or a possible hazardous safety condition to service personnel and occupants. Company employees and/or contractors are not authorized to waive this warning.

TABLE OF CONTENTS

SAFETY CONSIDERATIONS	4-5
MODEL NOMENCLATURE	6
GENERAL INFORMATION	7
INTRODUCTION	7
STORAGE	8
SHIPPING & PACKAGE LIST	8
UNIT INSPECTION CHECKLIST	9
UNIT DIMENSIONAL DATA	10-14
UNIT PHYSICAL DATA	14
ELECTRICAL DATA	15
INSTALLATION	16-22
ELECTRICAL	23
APPLICATION	24-28
CONTROLS	29-35
PERFORMANCE DATA	36-47
WIRING DIAGRAMS	48-54
CIRCUIT SCHEMATIC	55-56
STARTUP INSTRUCTIONS	56-57
STARTUP & PERFORMANCE CHECKLIST INSTRUCTIONS	57
MAINTENANCE & SERVICE	58
TROUBLESHOOTING	59-60
SUPPORT/REFERENCE MATERIAL	61
STARTUP & PERFORMANCE CHECKLIST	62
NOTES	63

SAFETY CONSIDERATIONS



1. **READ THE ENTIRE MANUAL BEFORE STARTING THE INSTALLATION.**
2. These instructions are intended as a general guide and do not supersede national, state, or local codes in any way.
3. Altering the product, improper installation, or the use of unauthorized factory parts voids all warranty or implied warranty and may result in adverse operation and/or performance or may result in hazardous conditions to service personnel and occupants. Company employees or contractors are not authorized to waive this warning.
4. This product should only be installed and serviced by a qualified, licensed, and factory authorized installer or service agency.
5. All “kits” and “accessories” used must be factory authorized when modifying this product. Refer and follow instructions packaged with the kits or accessories when installing.

RECOGNIZE THE FOLLOWING SAFETY NOTATIONS THROUGHOUT THIS MANUAL AND POSTED ON THE EQUIPMENT:

DANGER

Indicates an imminently hazardous situation which, if not avoided, will result in death or serious injury.

WARNING

Indicates a potentially hazardous situation or unsafe practices that could result in severe personal injury or death and/or damage to property.

WARNING

ELECTRIC SHOCK HAZARD

This warning signifies potential electrical shock hazards that could result in personal injury or death.

CAUTION

The CAUTION symbol indicates a potentially hazardous situation that may result in minor or moderate injury.

IMPORTANT

Suggests important procedure steps to insure proper installation, reliability, or operation.

NOTE

Used to highlight suggestions, which may result in enhanced installation, reliability or operation.

WARNING

FIRE OR EXPLOSION HAZARD

Failure to follow safety warnings exactly could result in dangerous operation, serious injury, death or property damage.

Improper servicing could result in dangerous operation, serious injury, death or property damage.

- Before servicing, disconnect all electrical power to the WSV6 water source heat pump.
- When servicing controls, label all wires prior to disconnecting. Reconnect wires correctly.

Verify proper operation after servicing.

SAFETY CONSIDERATIONS CONTINUED

CAUTION

Mechanical components and filters can become clogged with dirt and debris, which can cause damage to the system. The manufacturer does not warrant equipment subjected to abuse. Construction debris can void warranties and liability for equipment failure, personal injury, and property damage.

WARNING

Material in this shipment has been inspected at the factory and released to the transportation agency in good condition. When received, a visual inspection of all cartons should be made immediately. Any evidence of rough handling or apparent damage should be noted on the delivery receipt in the presence of the carrier's representative. If damage is found, a claim should be immediately filed against the carrier.

These models are designed for indoor installation only. Installation of this equipment, wiring, ducts, and any related components must conform to current agency codes, state laws, and local codes. Such regulations take precedence over general instructions contained in this manual.

WARNING

DO NOT USE FOR HEATING AND COOLING BUILDINGS OR STRUCTURE UNDER CONSTRUCTION!

WARNING

Improper installation, adjustment, alteration, service, or maintenance can cause property damage, personal injury or loss of life. Refer to the user's information manual provided with this water source heat pump. Installation and materials, service must be performed by a qualified installer, or service agency.

WARNING

Installation and service must be performed by a licensed professional installer (or equivalent), or service agency. Attempting to install or repair this unit without such background may result in product damage, personal injury or death.

WARNING

These instructions are intended as an aid to qualified, licensed service personnel for proper installation, adjustment and operation of this unit. Read these instructions thoroughly before attempting installation or operation. Failure to follow these instructions may result in improper installation, adjustment, service or maintenance possibly resulting in fire, electrical shock, property damage, personal injury or death.

WARNING



HIGH VOLTAGE!



Disconnect all power before servicing. Failure to do so may result in property damage, personal injury, or death.

CAUTION

Use care when handling compressors. Some surfaces could be hot!

CAUTION

Compressors should NOT be used to evacuate the air conditioning system. Vacuums this low can cause internal electrical arcing resulting in a damaged or failed compressor.

WARNING

The unit must be permanently grounded. Failure to do so can cause electrical shock resulting in severe personal injury or death.

WARNING

"USE COPPER SUPPLY WIRES ONLY!"

MODEL NOMENCLATURE

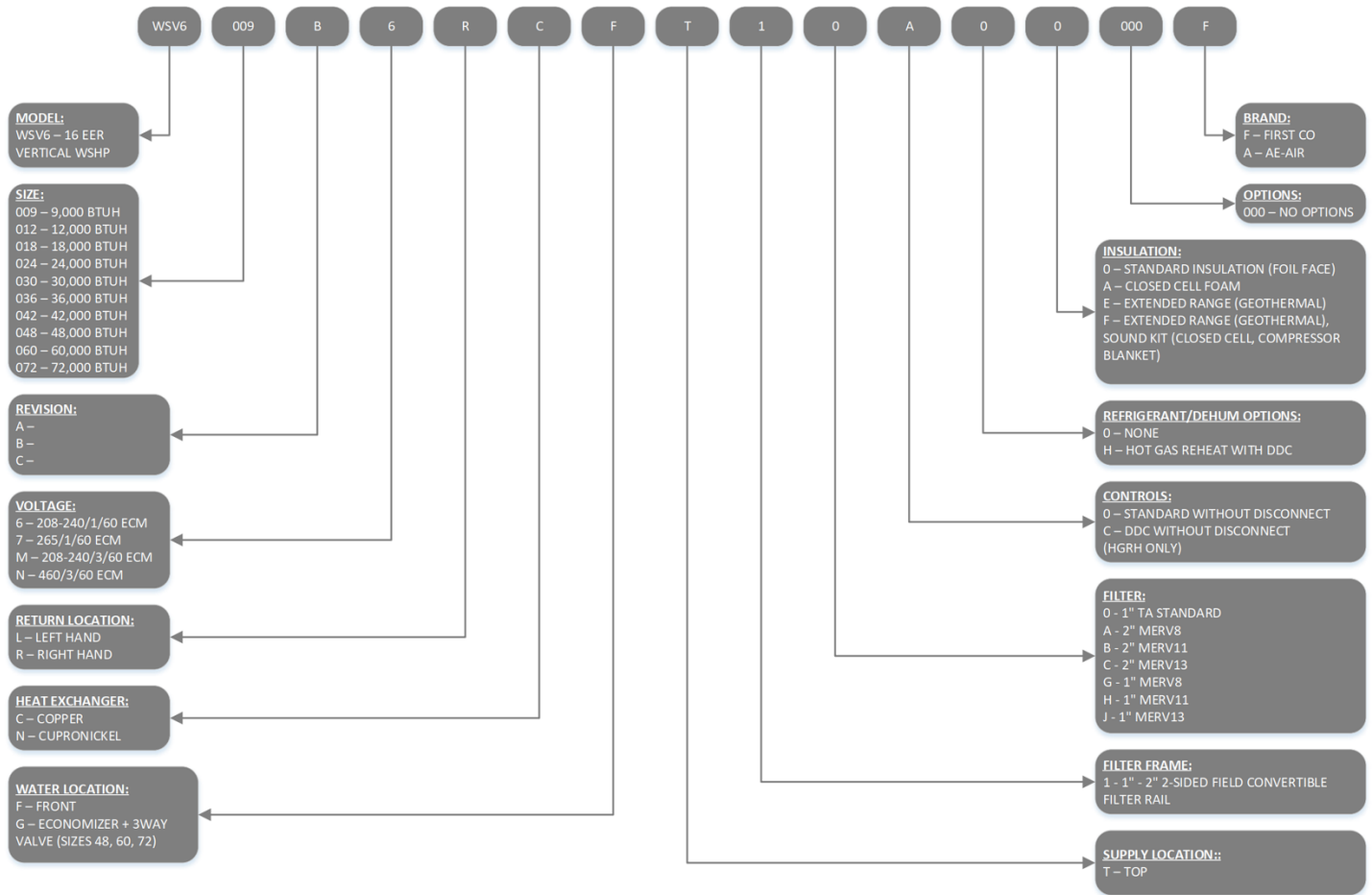

FIGURE 1 – Model Nomenclature

GENERAL INFORMATION

CAUTION

DO NOT use these units as a source of heating or cooling during the construction process. Mechanical components and filters can become clogged with dirt and debris, which can cause damage to the system.

The manufacturer does not warrant equipment subjected to abuse.

WARNING

ELECTRIC SHOCK HAZARD

Before servicing equipment, ALWAYS turn off all power to the unit. There may be more than one disconnect switch. Electrical shock can cause injury or death.

Clear surrounding area of all tools, equipment, and debris before operating this unit.

These instructions are provided for the installation of the WSV6 water source heat pump specifically. For any other related equipment, refer to the appropriate manufacturer's instructions.

CAUTION

This water source heat pump must never be operated under any circumstances without an air filter in place.

NOTE

Material in this shipment has been inspected at the factory and released to the transportation agency in good condition. When received, a visual inspection of all cartons should be made immediately. Any evidence of rough handling or apparent damage should be noted on the delivery receipt in the presence of the carrier's representative. If damage is found, a claim should be immediately filed against the carrier.

The WSV6 water source heat pump is designed for indoor installation only. Installation of this equipment, wiring, ducts, and any related components must conform to current agency codes, state laws, and local codes. Such regulations take precedence over general instructions contained in this manual.

CAUTION

Extreme caution must be taken that no internal damage will result from screws that are drilled into the cabinet.

INTRODUCTION

The HydroTech WSV6 series water to air heat pump provide the best combination of performance, efficiency and reliability in a compact form factor. The WSV6 series comes standard with ECM blower motors for high efficiency and comfort. All WSV6 models feature double compressor vibration isolation for quiet operation, easy to remove blower housing for quick service, as well as a single compressor designs to lower system complexity and improve serviceability.

All WSV6 models are certified to AHRI ISO Standard 13256-1. The WSV6 models are designed to operate with fluid temperatures between 50°F to 110°F in cooling mode and 50°F to 90°F in heating mode for continuous operation. For operation below 50°F or above 90°F entering water temperature, extended range (insulated tubing) option is needed, and sufficient water flow is required to prevent freezing. Antifreeze solution is required for any application with entering water below 50 degree F.

Cooling Tower/Boiler and Geo Thermal applications should have sufficient antifreeze solution when required to protect against extreme conditions and equipment failure. Frozen water coils are not covered under warranty.

These installation instructions are intended as a general guide only, for use by an experienced, qualified contractor.

CAUTION

Do not use this water source heat pump during any phase of construction.

STORAGE

Equipment should be stored in a clean dry, conditioned area with maximum temperatures up to 120°F [48.89°C] and minimum temperatures to 32°F [0°C]. Units should be stored upright and in an indoor environment. It is recommended to leave packaging on the unit until the installation is to begin.

⚠ WARNING ⚠
 Store cabinets how they are shipped (vertical), keeping them crated and on their pallets for protection. Failure to follow these instructions may result in improper installation, adjustment, service or maintenance, property damage, personal injury or death.

DO NOT operate these units during the construction process. Mechanical components and filters could become clogged with dirt and debris, which can cause damage to the system.

The manufacturer does not warrant equipment subjected to abuse.

⚠ CAUTION ⚠
 Stacking of the WSV6 Systems is strictly prohibited. Stacking units may result in system and/or property damage

SHIPPING & PACKAGE LIST

i NOTE i
 Material in this shipment has been inspected at the factory and released to the transportation agency in good condition. When received, a visual inspection of all cartons should be made immediately. Any evidence of rough handling or apparent damage should be noted on the delivery receipt in the presence of the carrier’s representative. If damage is found, a claim should be immediately filed against the carrier.

SHIPPING INSTRUCTIONS

WSV6 units must remain in the upright position as seen in **FIGURE 2 – Standard Packaging** throughout the shipping and handling process to maintain a proper level of oil in the compressor.

i NOTE i
 Shrink-wrap is located around the unit for protection. Remove before installation.

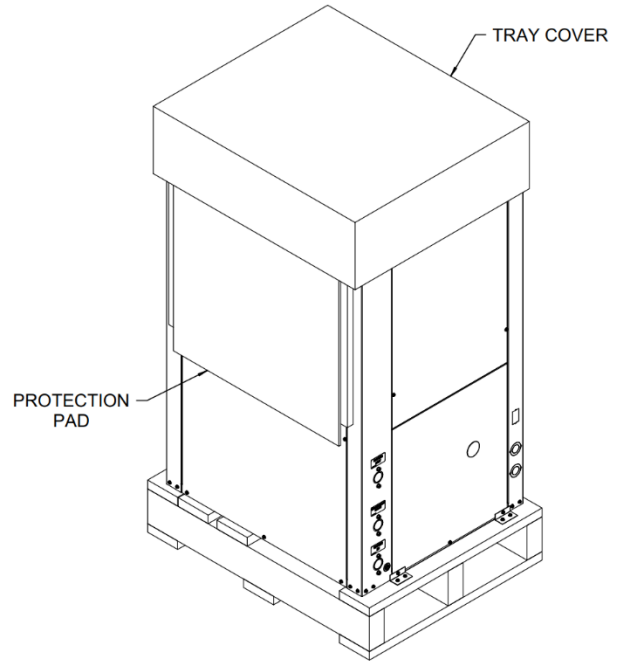

NOTE:
SHRINK WRAP AROUND UNIT

FIGURE 2 – Standard Packaging

PACKAGE LIST

The units will be shipped with the following items:

- 1- WSV6 unit:
 - A- Shipping brackets
 - a. Screws
- 2- Literature package
 - A- IOM - Installation & Operations Manual

Check the unit for shipping damage; if found, immediately contact the last carrier.

UNIT INSPECTION CHECKLIST

Complete the inspection procedures below before preparing unit for installation:

- 1) Visually inspect unit for any shipping damage. Damage must be reported immediately to the shipping company to make a claim.
- 2) Ensure that the carrier makes proper notation of any shortages or damage on all copies of the freight bill and completes a common carrier inspection report.
- 3) Verify that unit nameplates on the data label match the sales order or bill of lading (including, unit configuration, size and voltage).
- 4) Immediately before installation, remove unit front panel and verify that all electrical connections are tight and that there are no loose wires.
- 5) Check to make sure that the refrigerant piping is free from any kinks and there is no interference between unit piping and sheet metal or electrical wires.
- 6) Check that the blower spins freely within the housing and that there are no obstructions between the wheel and housing. The wheel can sometimes come loose in shipping.
- 7) Ensure that the evaporator distributor tubes are not touching one in another and that they are over the drain pan.
- 8) Check the air-coil fins for any damage during shipping.
- 9) Ensure that the shipping screws are removed from the unit. Refer to **FIGURE 3 – Standard Packaging with Brackets** for more information.

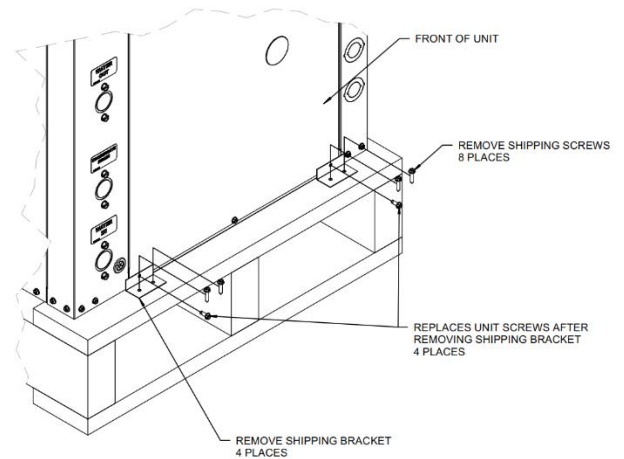

FIGURE 3– Standard Packaging with Brackets



NOTE



Check the unit nameplate for correct voltage with the plans before installing the equipment. Also, make sure all electrical ground connections are made in accordance with local code.

UNIT DIMENSIONAL DATA

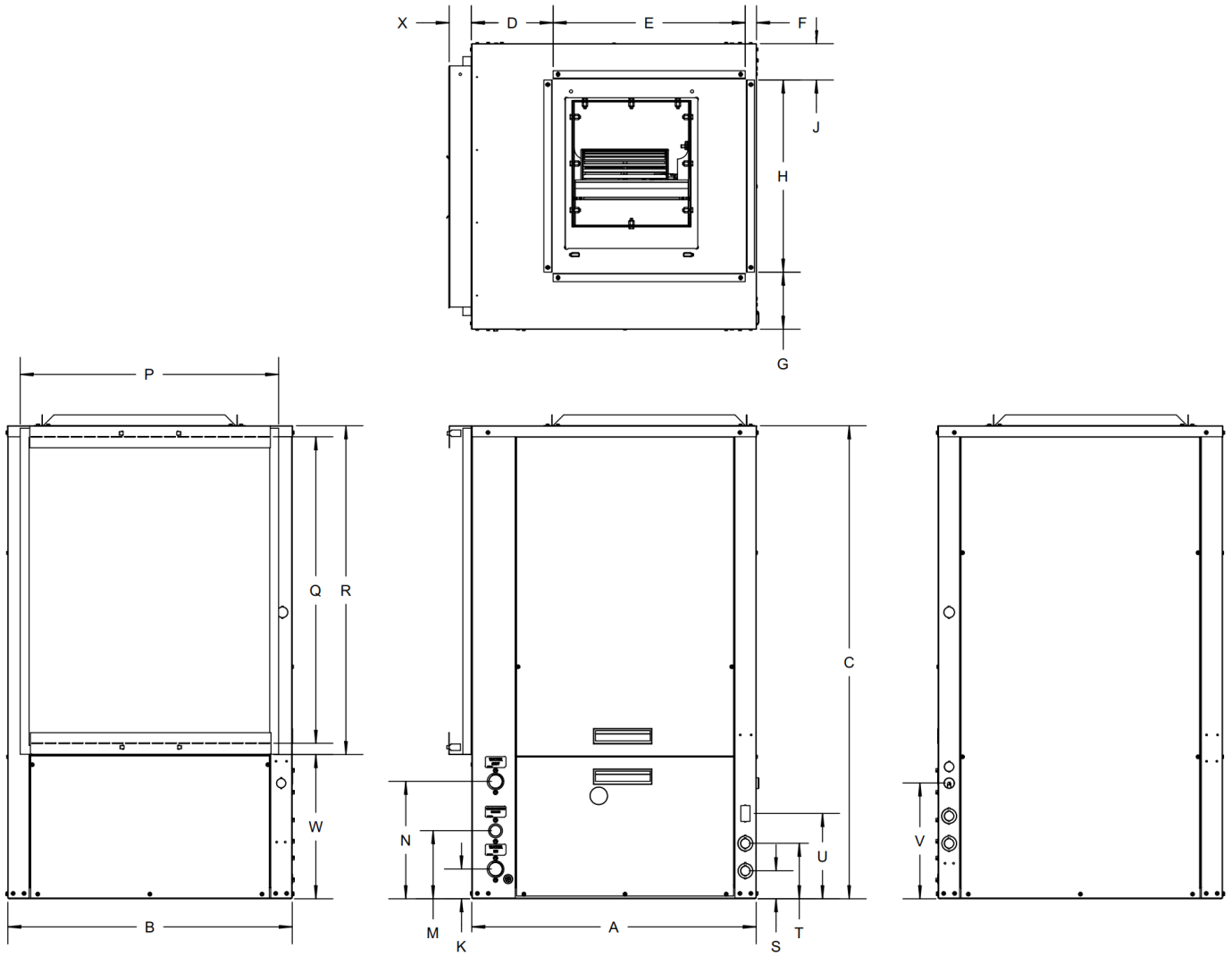

FIGURE 4 – Unit Dimensions

UNIT DIMENSIONAL DATA CONTINUED

DIMENSIONAL DATA									
MODEL	OVERALL CABINET			SUPPLY CONNECTIONS					
	A	B	C	D	E	F	G	H	J
WSV6009	21.50	21.50	36.25	9.50	7.75	4.25	4.50	12.75	4.25
WSV6012	21.50	21.50	36.25	9.50	7.75	4.25	4.50	12.75	4.25
WSV6018	21.50	21.50	36.25	5.50	13.75	2.25	3.50	16.25	1.75
WSV6024	21.50	21.50	36.25	5.50	13.75	2.25	3.50	16.25	1.75
WSV6030	21.50	21.50	39.25	5.50	13.75	2.25	3.50	16.25	1.75
WSV6036	21.50	26.00	43.25	5.00	15.75	0.75	5.00	16.25	4.75
WSV6042	26.00	26.00	43.25	7.25	17.75	1.00	5.00	17.75	3.25
WSV6048	26.00	26.00	43.25	7.25	17.75	1.00	5.00	17.75	3.25
WSV6060	26.00	26.00	51.25	5.25	19.00	1.75	4.75	19.00	2.25
WSV6072	26.00	26.00	51.25	5.25	19.00	1.75	4.75	19.00	2.25

Table 1 – Unit Dimensional Data

DIMENSIONAL DATA CONTINUED												
MODEL	WATER CONNECTION			RETURN AIR CONNECTION			ELECTRICAL CONNECTION				W	X
	K	M	N	P	Q	R	S	T	U	V		
WSV6009	2.75	7.25	13.25	17.50	16.00	18.00	4.25	6.75	10.50	15.00	18.25	2.00
WSV6012	2.75	7.25	13.25	17.50	16.00	18.00	4.25	6.75	10.50	15.00	18.25	2.00
WSV6018	2.75	7.25	13.25	17.50	16.00	18.00	4.25	6.75	10.50	15.00	18.25	2.00
WSV6024	2.75	7.25	12.75	17.50	16.00	18.00	4.25	6.75	10.50	15.00	18.25	2.00
WSV6030	2.75	7.25	12.75	17.50	18.00	20.00	4.25	6.75	10.50	15.00	19.25	2.00
WSV6036	2.75	7.25	12.75	17.50	22.00	24.00	4.25	6.75	10.50	15.00	19.25	2.00
WSV6042	2.75	6.25	10.75 LH 16.75 RH	22.00	28.00	30.00	2.50	5.00	7.75	10.50	13.25	2.00
WSV6048	2.75	6.25	10.75	22.00	28.00	30.00	2.50	5.00	7.75	10.50	13.25	2.00
WSV6060	2.75	6.25	10.75	22.00	28.00	38.00	2.50	5.00	7.75	10.50	13.25	2.00
WSV6072	2.75	6.25	10.75	22.00	28.00	38.00	2.50	5.00	7.75	10.50	13.25	2.00

Table 2 – Unit Dimensional Data Continued

UNIT DIMENSIONAL DATA - ECONOMIZER

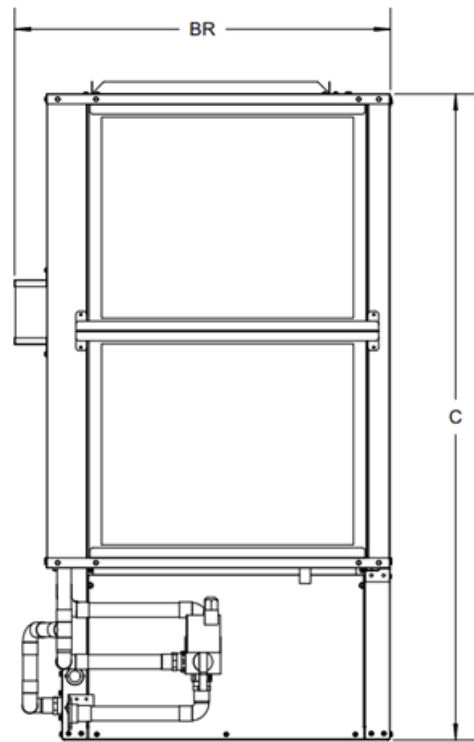
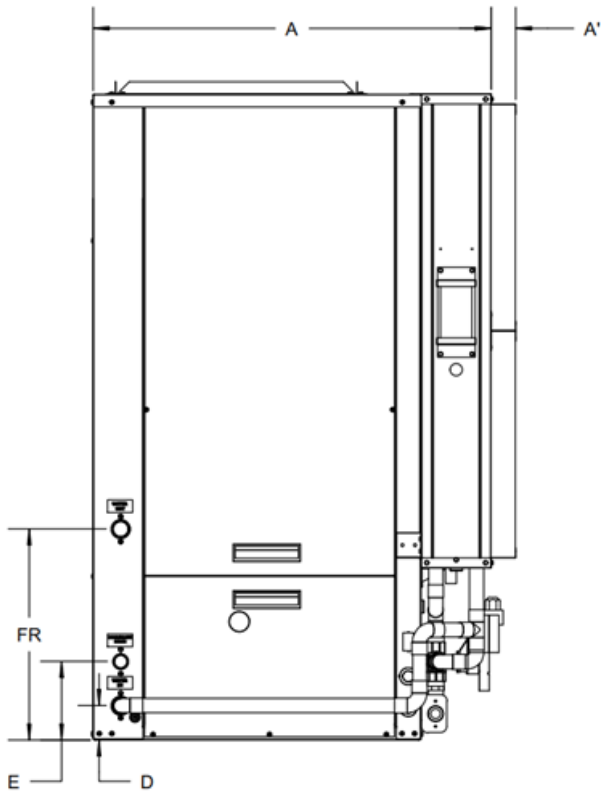
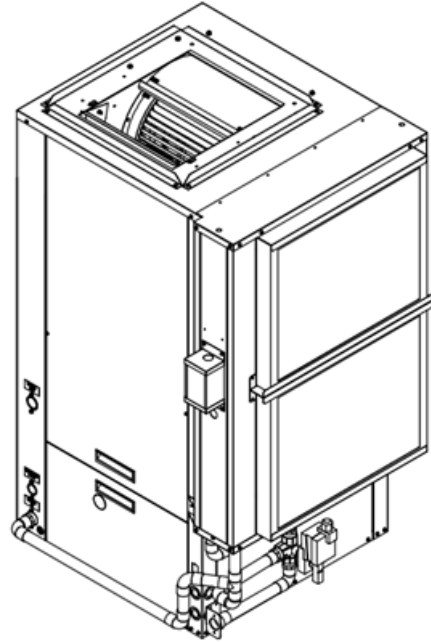
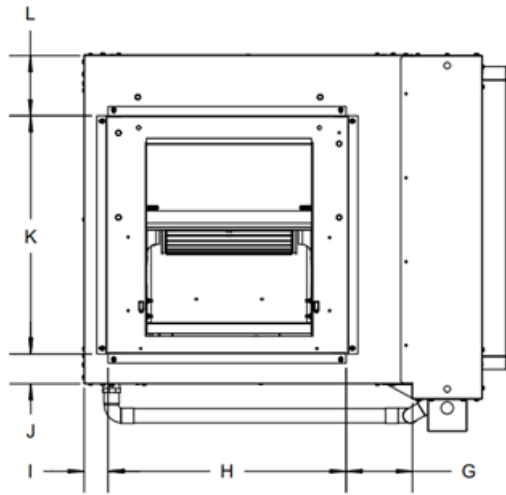

FIGURE 5 – Unit Dimensions – Economizer RH

UNIT DIMENSIONAL DATA - ECONOMIZER CONTINUED

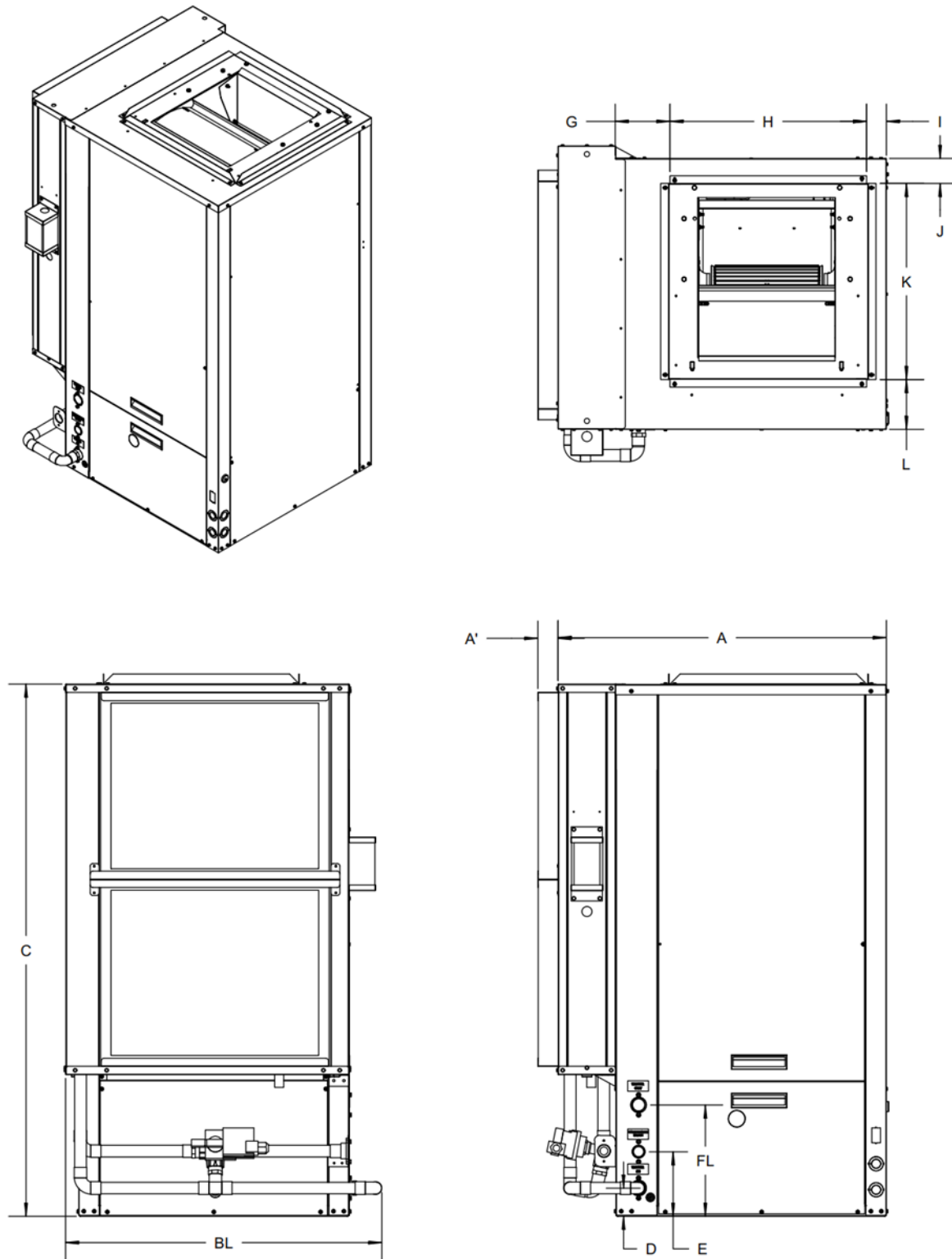

FIGURE 6 – Unit Dimensions – Economizer LH

UNIT DIMENSIONAL DATA - ECONOMIZER CONTINUED

DIMENSIONAL DATA - ECONOMIZER																
MODEL	A	A'		B		C	D	E	F		G	H	I	J	K	L
		1"	2"	L	R				L	R						
WSV6048	31.59	0.91	1.91	30.39	29.82	43.16	2.72	6.22	10.72	16.72	5.25	18.88	1.92	2.38	18.88	4.77
WSV6060	31.59	0.91	1.91	30.39	29.82	51.20	2.72	6.22	10.72	16.72	5.25	18.88	1.92	2.38	18.88	4.77
WSV6072	31.59	0.91	1.91	30.39	29.82	51.20	2.72	6.22	10.72	16.72	5.25	18.88	1.92	2.38	18.88	4.77

Table 3 – Unit Dimensional Data - Economizer

UNIT PHYSICAL DATA

PHYSICAL DATA										
WSV6 MODELS	009	012	018	024	030	036	042	048	060	072
UNIT INFORMATION										
Compressor Type (Qty)	Rotary (1)				Scroll (1)					
Factory Charge (R410A) lbs. [oz]	2.2 [36]	2.6 [42]	2.5 [39]	2.7 [43]	3.1 [50]	3.9 [63]	5.0 [80]	4.8 [76]	6.3 [100]	6.3 [100]
Fan Motor Type (Qty)	ECM (1)	ECM (1)	ECM (1)	ECM (1)	ECM (1)	ECM (1)	ECM (1)	ECM (1)	ECM (1)	ECM (1)
Fan Motor HP	1/4	1/4	1/3	1/2	1/2	1/2	3/4	1	1	1
Blower Wheel Size (D x W) in.	6.75 x 7	6.75 x 7	9 x 7	9 x 7	10 x 8	10 x 8	10 x 8	10 x 8	11 x 10	11 x 10
Water Connection FPT (in)	3/4	3/4	3/4	3/4	3/4	3/4	1	1	1	1
COAX Volume (US Gallons)	0.12	0.14	0.14	0.36	0.43	0.53	0.62	0.91	0.91	1.08
Condensate Connection FPT (in)	3/4	3/4	3/4	3/4	3/4	3/4	3/4	3/4	3/4	3/4
Air Coil Dimension (H x W) in.	18 x 16.375	18 x 16.375	18 x 16.375	18 x 16.375	20 x 16.25	24 x 20.875	28 x 20.875	28 x 20.875	36 x 20.875	36 x 20.875
Filter Size (H x W) in.	18 x 20	18 x 20	18 x 20	18 x 20	20 x 20	24 x 24	24 x 30	24 x 30	18 x 24 20 x 24	18 x 24 20 x 24
Filter (Qty)	1	1	1	1	1	1	1	1	2	2
Operating Weight lb.	155	160	190	205	215	250	290	315	360	365
Shipping Weight lb.	164	166	195	208	221	254	295	320	365	370

Table 4 – Physical Data

ELECTRICAL DATA

ELECTRICAL DATA							
MODEL	VOLTAGE-PH-HZ	COMPRESSOR		BLOWER MOTOR		MIN. CIRCUIT AMPACITY	MAX. CIRCUIT PROTECTION
		RLA	LRA	FLA	HP		
WSV6009	208/230-1-60	3.7	22	2.3	1/4	7	15
	265-1-60	3.5	22	2.3	1/4	7	15
WSV6012	208/230-1-60	4.7	25	2.3	1/4	9	15
	265-1-60	4.2	22	2.3	1/4	8	15
WSV6018	208/230-1-60	9	56.3	2.8	1/3	15	20
	265-1-60	7.1	43	2.6	1/3	12	15
WSV6024	208/230-1-60	10.9	62.9	4.6	1/2	19	25
	265-1-60	9.0	54	3.6	1/2	15	20
	208/230-3-60	7.1	55.4	4.6	1/2	14	20
	460-3-60	3.5	28	2.1	1/2	7	15
WSV6030	208/230-1-60	15.4	82.6	4.6	1/2	24	35
	265-1-60	12.2	72	3.6	1/2	19	30
	208/230-3-60	10.0	71	4.6	1/2	18	25
	460-3-60	4.7	38	2.1	1/2	8	15
WSV6036	208/230-1-60	15.4	83.9	4.6	1/2	24	35
	265-1-60	13.5	72	3.6	1/2	21	30
	208/230-3-60	10.4	73	4.6	1/2	18	25
	460-3-60	5.8	38	2.1	1/2	10	15
WSV6042	208/230-1-60	19.2	123.9	6.3	3/4	31	45
	265-1-60	16.0	87	4.9	3/4	25	40
	208/230-3-60	13.5	88	6.3	3/4	24	35
	460-3-60	6.0	44	3.2	3/4	11	15
WSV6048	208/230-1-60	19.6	130	7.6	1	33	50
	265-1-60	16.3	98	6.6	1	27	40
	208/230-3-60	13.7	83.1	7.6	1	25	35
	460-3-60	6.2	41	4.0	1	12	15
WSV6060	208/230-1-60	24.4	144.2	7.6	1	39	60
	265-1-60	19.9	130	6.6	1	32	50
	208/230-3-60	16.0	110	7.6	1	28	40
	460-3-60	7.8	52	4.0	1	14	20
WSV6072	208/230-1-60	30.8	178	7.6	1	47	70
	208/230-3-60	19.6	136	7.6	1	33	50
	460-3-60	8.2	66.1	4.0	1	15	20

Table 5 – Electrical Data

INSTALLATION

REQUIREMENTS

Follow manufacturer's installation instructions, as well as local and municipal building codes.

INSTALLATION PRECAUTIONS



CAUTION



Always wear all appropriate personal protection Equipment when installing and servicing these units.



WARNING



Use multiple people when moving and installing these units. Failure to do so could result in injury or death.



CAUTION



Contact with metal edges and corners can result injury. Protective gloves should be worn when handling. Exercise caution when installing and servicing unit.

Observe the following precautions for typical installation:

- Always use proper tools and equipment.
- No wiring or any work should be attempted without first ensuring the unit is completely disconnected from the power source and locked out. Also, verify that a proper permanent and uninterrupted, ground connection exists prior to energizing power to the unit.
- Review unit nameplate and wiring diagram for proper voltage and control configurations. This information may vary from unit to unit.



CAUTION



When the unit is in operation components are rotating at high speeds and caution should be taken.



WARNING



When soldering and brazing, it is recommended to have a fire extinguisher readily available. When soldering and brazing close to valves or sensitive components, heat shields or wet rags are required to prevent damage to the valves or components.



NOTE



Insulation is installed in the unit to provide a barrier between varying atmospheres outside and within the unit. If insulation is damaged condensation can occur and can lead to corrosion, component failure, and possible property damage. Damaged insulation must be repaired prior to the operation of the unit. Insulation will lose its effectiveness and value when wet, torn, separated, and/or damaged.



CAUTION



When servicing this equipment, because of high pressures, make sure the reversing valve, expansion device, filter drier and other components are specifically designed for R-410A refrigerant.

ONLY USE service equipment specifically designated for use with R-410A.



WARNING



R-410A can become combustibile if mixed with air at elevated temperature and/or pressure. Failure to follow this warning could result in property damage and personal injury or death.



CAUTION



Do not operate this equipment without an air filter.

INSTALLATION CONTINUED

UNIT CLEARANCE REQUIREMENTS

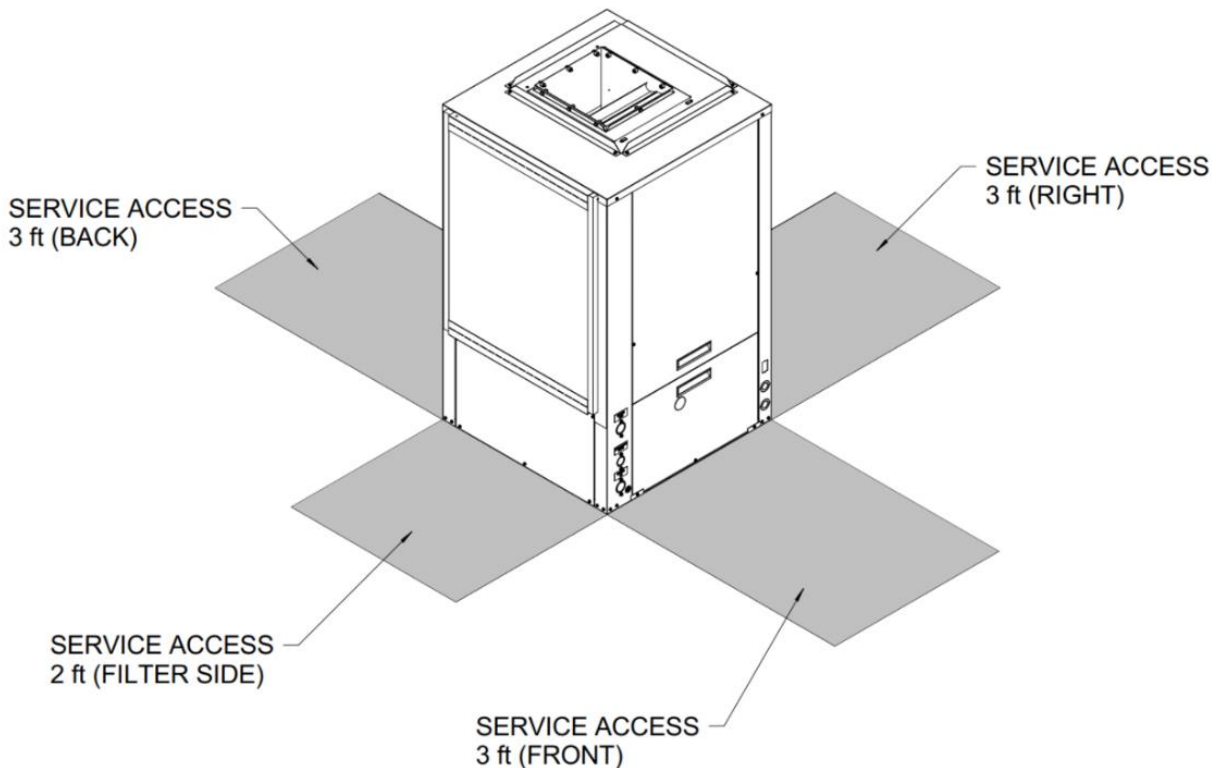

FIGURE 7 – Unit Clearance Requirements

MOUNTING DETAILS

Locate the unit in an area that provides minimum clearance accesses as specified by **FIGURE 7 – Unit Clearance Requirements**. Also, refer to this figure for detailed information on unit dimensional sizes. Consider all additional clearances needed for water connections, electrical connections, duct connections and sufficient return airflow.

UNITS ARE ONLY INTENDED FOR INDOOR INSTALLATION

DO NOT locate unit in areas subject to freezing temperatures or where high humidity levels could cause cabinet condensation. WSV6 units are available in right- and left-hand configurations. Units should be mounted level with a proper drain pan pitch toward the condensate drain as seen in **FIGURE 8 – Mounting Installation**. 3/8"-1/2" vibration isolation pads must be used to minimize vibration transmission.



NOTE



It is important to ensure the unit is securely mounted and that the mounting structure is sufficient to support the operating weight of the equipment. Place and size all anchors to ensure a safe and durable installation.

INSTALLATION CONTINUED

MOUNTING DETAILS CONTINUED

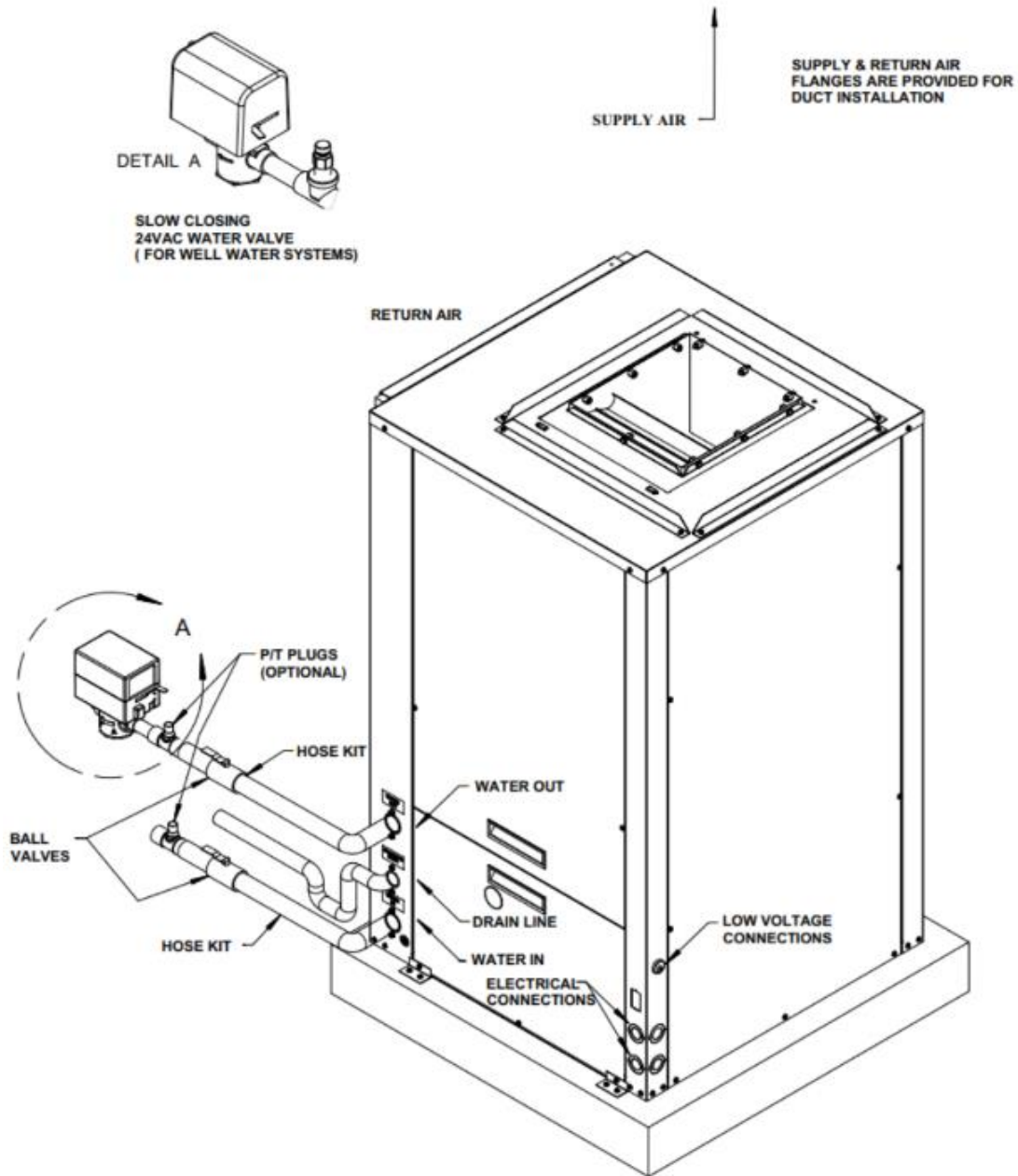

FIGURE 8 – Mounting Installation

INSTALLATION CONTINUED

PIPING NOTES



CAUTION



Prior to making piping connections, contractor must clean and flush water loop system. Failure to clean/flush system may result in excessive noise, tripping, and premature component failure.

1. Flush all field piping prior to connection to clear all debris.
2. Open all valves (mid-way for hand valves, manually open motorized valves) prior to soldering and brazing. Use proper heat shields to protect valve bodies.
3. When soldering or brazing to the unit, it is recommended to have a fire extinguisher readily available.
4. Use proper soldering and brazing techniques to protect valve bodies and unit components.
5. Avoid rapid quenching of soldered joints to prevent weakening.
6. Make provisions for expansion and contraction of piping systems to provide movement with temperature changes. Failure to make proper provisions will result in damage and failure of piping, fittings, and valves throughout the system.
7. **DO NOT** insulate the heads or motorized portion of control valves. Excessive heat build-up can cause damage and affect proper operation of the system.
8. Consider electrical routing when installing field piping.
9. Observe all regulations and codes governing installation of piping.
10. When all connections are complete, pressure test the system, and repair any leaks or faulty joints. Hydronic systems are not designed to hold pressurized air and should only be tested with water. Failure to observe this note could damage the system.

PIPING INSTALLATION

All piping must be adequately sized to meet the designed water flow as specified for the specific application, and must adhere to all applicable codes. Piping connections on the equipment are not necessarily indicative of the proper supply and return line sizes.

On units with plastic drain pans the drain connection must be made hand tight only.

Chilled water piping must be properly insulated to prevent condensation and potential property damage. It is also recommended that all piping be insulated to prevent freezing in unconditioned spaces.



CAUTION



Do not bend or kink supply lines or hoses. For all supply lines or hoses of 1-1/2" OD or greater, use proper sized fitting is recommended to prevent piping damage and potential restrictions in water flow.



NOTE



For all applications, 50°F minimum entering water temperature and rated water flow is required to prevent freezing. Antifreeze solution is required for any application with entering water below 50°F. Frozen water coils are not covered under warranty.



NOTE



All manual flow valves used in the system must be ball valves. Globe and gate valves must not be used due to high pressure drop and poor throttling characteristics. Never exceed the recommended water flow rates. Serious erosion or damage of the water to refrigerant heat exchanger could occur.



NOTE



When anti-freeze is used in the loop, insure that it is compatible with the Teflon tape that is applied.

The WSV6 water source heat pump are designed to operate with the entering liquid temperature between 50°F and 110°F. With the extended range option, the heat pump model can operate with entering liquid temperatures between 50-110°F. Below 50°F. antifreeze solution must be used to prevent freezing. Frozen water coils are not covered under warranty.

INSTALLATION CONTINUED

PIPING INSTALLATION CONTINUED



NOTE



Do not allow hoses to rest against structural building components. Compressor vibration may be transmitted through the hoses to the structure, causing unnecessary noise complaints.

Always check carefully for water leaks and repair appropriately. Units are equipped with female pipe thread fittings. Consult the specification sheets for sizes. Teflon tape should be used when connecting water piping connections to the units to insure against leaks and possible heat exchanger fouling.

Do not over tighten the pipe connections. Flexible hoses should be used between the unit and rigid piping to avoid vibration transmission into the structure.

Ball valves should be installed in the supply and return lines for unit isolation and unit water flow balancing. Pressure / temperature ports are recommended in both the supply and return lines for system flow balancing. Water flow can be accurately set by measuring the water side pressure drop of the water to refrigerant heat exchanger.



CAUTION



Water piping exposed to extreme low ambient temperatures is subject to freezing and possible rupture. Proper prevention should be taken to prevent pipe freezing or equipment damage or failure may occur. Failure to follow this warning could result in property damage.



CAUTION



Ground loop applications require extended range equipment and optional refrigerant/water circuit insulation.



NOTE



Geothermal Closed Loop Systems Operation of a WSV6 Water Source Heat Pump unit on a closed loop application requires the extended range option.

ANTIFREEZE

Anti-freeze solutions must be utilized when low loop temperatures are expected to occur. In areas where

entering loop temperatures drop below 50°F or where piping will be routed through areas subject to freezing, antifreeze is needed. Alcohols and glycols are commonly used as antifreeze agents. Freeze protection should be maintained to 15°F below the lowest expected entering loop temperature. For example, if the lowest expected entering loop temperature is 30°F, the leaving loop temperature would be 22°F to 25°F. Therefore, the freeze protection should be at 15°F (30°F-15°F=15°F).

LOW WATER TEMPERATURE CUTOFF SELECTION

The Digital Control Module allows the field selection of low water (or water-antifreeze solution) temperature limit by clipping jumper JW1 and JW2, which changes the sensing temperature associated with thermistor CO1 and CO2 respectively. Note that the CO1 thermistor is located on the refrigerant line between the coaxial heat exchanger and expansion device (TXV). Therefore, CO1 is sensing refrigerant temperature, not water temperature, which is a better indication of how water rate/temperature is affecting the refrigeration circuit. The factory setting for CO1 is for systems using water (30°F [-1.1°C] refrigerant temperature). In low water temperature (extended range) applications with antifreeze (most ground loops), jumper JW1 should be clipped to change the setting to 10°F [-12.2°C] refrigerant temperature, a more suitable temperature when using an antifreeze solution. All units operating with entering water temperatures below 50°F [10°C] must include the optional water/refrigerant circuit insulation package to prevent internal condensation.



CAUTION



Disconnect power BEFORE the jumper wires are clipped. Failure to do so could result in equipment and/or property damage.



WARNING



For all applications, 50°F minimum entering water temperature and sufficient water flow is required to prevent freezing. Antifreeze solution is required for any application with an entering water temperature below 50°F or, if either JW1 or JW2 cut-out limits are set to 10°F (clipped). Failure to follow this warning could result in heat exchanger, equipment, or property damage.

INSTALLATION CONTINUED

CONDENSATE DRAINAGE

Condensate drain lines must be properly installed with adequate slope away from unit to ensure proper drainage. A minimum trap of 1.5 inches must be installed to isolate the negative pressures of the drain pan from the drain line. Refer to **Figure 9 – Condensate Drainage** for schematic information on the condensate drain lines.

CAUTION

Check the condensate overflow sensor for proper operation and adjust if necessary. Final field adjustments ensures proper operation to avoid property damage.

CAUTION

On units with plastic drain pans, the drain connection must be made hand tight only.

CAUTION

Both the supply and return water lines will sweat if subjected to low water temperature. These lines should be insulated to prevent water damage to the property.

CAUTION

Units equipped with the economizer option must have a separate externally trapped drain line for condensate removal.

Insulation is not required on loop water piping except where the piping runs through unconditioned areas, outside the building or when the loop water temperature is below the minimum expected dew point of the pipe ambient conditions. Insulation is required if loop water temperature drops below the dew point.

Units are supplied with either a copper or optional cupro-nickel water to refrigerant heat exchangers. Copper is adequate for ground water that is not high in mineral content. Should your well driller express concern regarding the quality of the water or should any known hazards exist in your area then we recommend proper testing to assure the well water quality is suitable for use with water source equipment. In conditions anticipating moderate scale formation or in brackish water a cupro-nickel heat exchanger is recommended.

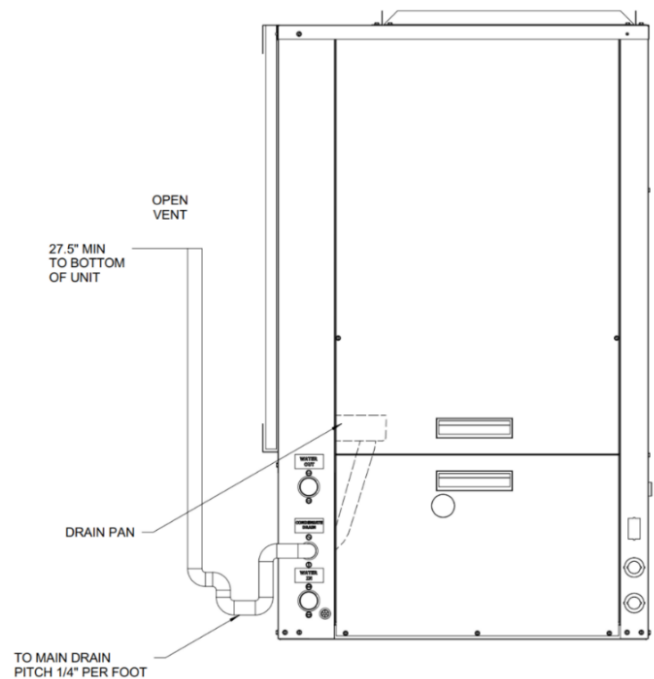

FIGURE 9 – Condensate Drainage

DUCTWORK

Discharge ductwork is normally used with these units. When return air ductwork is required, the unit is supplied with 1-inch filter rack/duct collar for connection of return air ductwork. All ductwork must be installed in accordance with National Fire Protection Assoc. Codes 90A and 90B. Supply and Return ducts must be sized properly as to not exceed static pressure capabilities. Ducts should be adequately insulated to prevent condensation and to minimize heat loss. A flexible connector is recommended for supply air connections on metal duct systems.

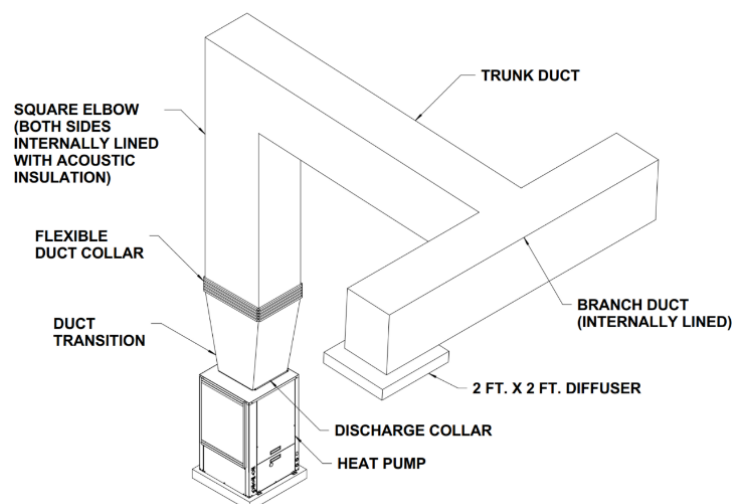

FIGURE 10 – Discharge Ducting

INSTALLATION CONTINUED

DISCHARGE DUCTING

All ductwork should conform to industry standards of good practice as described in ASHRAE System Guide. A field supplied discharge duct system will normally consist of flexible connector at the unit, a non-insulated transition piece to the full duct size, a short run of duct, an elbow without vanes and a trunk duct teeing into a branch circuit with discharge diffusers as shown in **FIGURE 10 – Discharge Ducting**. The transition piece must not have an angle greater than 30° or severe loss of air performance may result.

DO NOT connect the full duct size to the unit discharge collar without using a transition piece down to the size of the unit discharge collar. With metal material, the sides of the elbow and entire branch duct should be internally lined with acoustic insulation for sound attenuation. Glass Fiber duct board material is more absorbing and may permit omission of the flexible connector. The ductwork should be laid out so that there is no line of sight between the unit discharge and the distribution diffusers.

RETURN AIR DUCTING

Return air duct can be brought in through a wall grille and then to the unit. The return duct system will normally consist of flexible connector at the unit and a trunk duct to the return air grille. With metal duct material, the return air duct should be internally lined with acoustic insulation for sound attenuation. Glass Fiber duct board material is more absorbing and may permit omission of the flexible connector. A 1-inch air duct collar flange is included on the filter rack for ducted return air application. A flexible duct collar can then be attached between a duct transition and the return air ductwork. The return air duct transition must be the same size as the return air coil face area. See **FIGURE 11 – Return Air Ducting**.

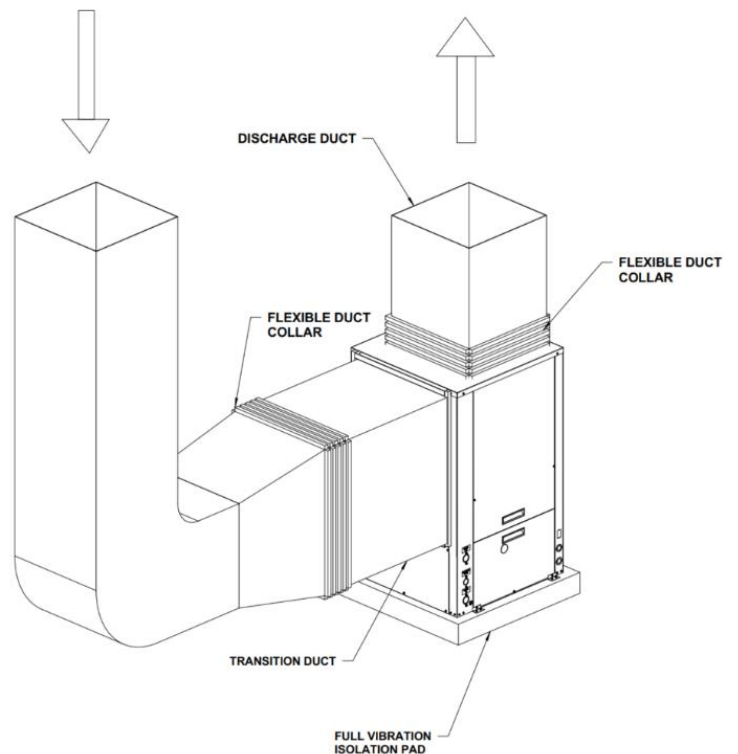

FIGURE 11 – Return Air Ducting



CAUTION



Follow the filter rack kit installation instructions & recommendations carefully.

ELECTRICAL

HIGH VOLTAGE

WARNING

ELECTRIC SHOCK HAZARD

Disconnect all power supplies before servicing. Lock out/tag out to prevent accidental electrical shock. NOTE: There may be multiple power sources supplying the unit.

WARNING

Use copper conductors only. Install all parts and panels before operation of unit. Failure to follow these warnings can result in injury or death.

All wiring must comply with local and national code requirements. Units are provided with wiring diagrams and nameplate data to provide information required for necessary field wiring.

The WSV6 water source heat pumps are provided with a class 2 transformer for 24VAC control circuits. Should any add-on accessory or component also have a class 2 transformer furnished, care must be taken to prevent interconnecting outputs of the two transformers by using a thermostat with isolating contacts.

WARNING

Connect ground wire to ground terminal marked "GND". Failure to do so can result in injury or death.

CAUTION

Any device that has been furnished by the factory for field installation must be wired in strict accordance with the associated wiring diagram. Failure to do so could damage components and void warranties.

208-230 VOLT OPERATION

All 208-230 Volt units are factory wired for 230 Volt operation. For 208 Volt operation, moving/changing/rewiring the line voltage tap on the 24 Volt control transformer is required. See note 3 on the wiring diagram for instruction.

LOW VOLTAGE

THERMOSTAT

A standard 24 VAC Heat Pump thermostat is required that will operate the reversing valve in the cooling mode.

Thermostat connections and their functions are below in **FIGURE 12 – Thermostat Connections** as follows:

- C – Transformer 24VAC Common
- O – Reversing Valve (energized in cooling)
- Y – Compressor Contactor
- R – Transformer 24VAC Hot
- G – Evaporator Blower

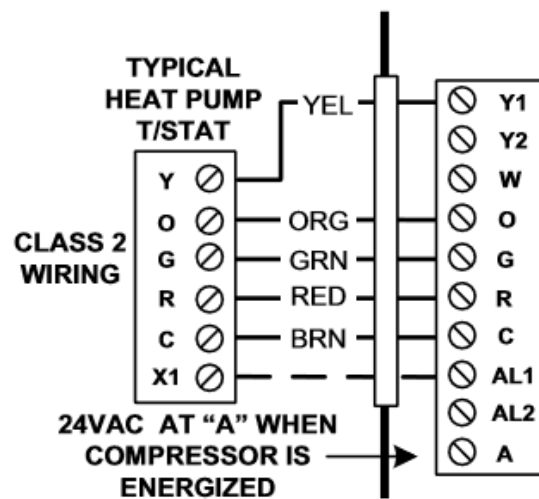

FIGURE 12 – Thermostat Connections

THERMOSTAT INSTALLATION



The Thermostat should be located on an interior wall in a larger room, away from supply duct draft. Position the thermostat back plate against the wall so that it appears level and so the thermostat wires protrude through the middle of the back plate mounting holes and drill holes with a 3/16" (5mm) bit. Install supplied anchors and secure plate to the wall. Thermostat wire must be 18 AWC wire.

APPLICATION



COOLING TOWER/BOILER APPLICATION

To ensure optimum cooling and heating performance, the cooling tower and boiler loop temperature should be maintained between 55-75°F in the heating mode and 60-95°F in the cooling mode. In the cooling mode, heat is rejected from the heat pump's refrigerant into the water loop. A cooling tower and/or boiler may be required to maintain proper water temperature within the water loop. In an open cooling tower, chemical water treatment is mandatory to ensure water is free of corrosive materials.

In heating mode, heat is absorbed from the water loop into the heat pump's refrigerant. A boiler may be utilized to maintain the proper water temperature within the loop.

	CAUTION	
A boiler may be required in the water loop to maintain the loop water temperature between 55-75°F. Failure to maintain proper water loop temperatures could result in equipment failure and property damage, and void warranties.		

A secondary heat exchanger (plate frame between the unit and the open cooling tower) may also be used. It is imperative that all air is eliminated from the closed loop side of the heat exchanger to prevent condenser fouling.

	WARNING	
Use copper conductors only. Install all parts and panels before operation of unit. Failure to follow these warnings can result in injury or death.		

	CAUTION	
The manufacturer does NOT WARRANT equipment subjected to abuse. Dirt, piping chips or other foreign material can cause damage or failure to the water or to refrigerant heat exchanger.		

No unit should be connected to the supply or return piping until the water system has been completely cleaned and flushed to remove dirt, piping chips or other foreign material. Supply and return hoses should be connected together during this process to ensure the entire system is properly flushed. After the cleaning and flushing has taken place the unit may be connected to the water loop and should have all valves adjusted to

supply the proper flow rate for the unit. Nominal flow rate is 3 GPM per 12,000 BTUH of cooling.

EXTENDED RANGE OPERATION



Piping systems expected to utilize water temperature below 50°F require the extended range option, which includes closed cell installation on all piping surfaces to eliminate condensation. This application requires sufficient antifreeze solution to prevent the water loop against extreme temperature conditions and condenser coil freezing. Frozen condenser coil are not covered under warranty. A boiler may be required to maintain the minimum water temperature within the loop.

	WARNING	
Connect ground wire to ground terminal marked "GND". Failure to do so can result in injury or death.		

	CAUTION	
Any device that has been furnished by the factory for field installation must be wired in strict accordance with the associated wiring diagram. Failure to do so could damage components and void warranties.		

CLOSED LOOPS

Failure to maintain proper water loop temperatures could result in equipment failure and property damage, and void warranties. Consult the factory when running entering water temperatures below 50°F as additional pipe insulation may be required to avoid excessive sweating inside the unit. For applications below 50°F it is imperative that the system be operated with antifreeze solution. When a secondary heat exchanger is used (i.e. plate to plate; closed loop system) it is imperative that all air is purged from the system to prevent condenser fouling.

	CAUTION	
The entire water loop must be completely cleaned and flushed of all debris prior to final connections and unit operation.		
Valves should be adjusted to supply proper water flow rated for the unit.		
Failure to do so will VOID ALL FACTORY WARRANTY .		

APPLICATION CONTINUED

WATER WELL APPLICATION

REQUIREMENTS:

- 50° Minimum Entering Water Temperature
- Cupronickel Refrigerant Heat Exchanger

When a water well is used exclusively for supplying water to the heat pump, a cupronickel refrigerant heat exchanger is required and the well pump should operate only when the heat pump operate. A 24 Volt contactor can be wired to the ACC1 terminal on the Control Module which can be selected to be energize prior to or at compressor start-up, which would in turn energize the water pump to operate with the heat pump.

WELL WATER APPLICATION			
Potential Failure Mode	Water Chemistry Parameter	Copper	CuNi
Corrosion and Scaling	pH Level	7-9	7-9
	Hardness (Calcium or Magnesium Carbonate)	< 350 ppm	<350 ppm
	Langelier Saturation Index (LSI)	-0.5 to 0	-0.5 to 0
	Ryznar Stability Index (RSI)	6.2 – 6.8	6.2 – 6.8
	Hydrogen Sulfide	< 0.5 ppm	< 0.5 ppm
	Sulfates	< 125 ppm	< 125 ppm
	Chlorine	< 0.5 ppm	< 0.5 ppm
	Chlorides	< 20 ppm	< 150 ppm
	Carbon Dioxide	< 5 ppm	< 5 ppm
	Ammonia	< 2 ppm	< 2 ppm
	Ammonia Chloride, Nitrate, Hydroxide, Sulfate	< 0.5 ppm	< 0.5 ppm
Total Dissolved Solids (TDS)	< 1000 ppm	< 1500 ppm	
Iron Fouling	Iron, Iron Bacteria	< 0.2 ppm	< 0.2 ppm
	Iron Oxide	< 1 ppm	< 1 ppm
Erosion	Suspend Solids	< 10 ppm, < 600 Micron or 30 mesh filter size	< 10 ppm, < 600 Micron or 30 mesh filter size
	Design Water Velocity	3 GPM/TON	3 GPM/TON

Table 6 – Well Water Application Data

CAUTION

Minimum entering water temperature is 50°F. Failure to follow this warning could result in equipment failure and property damage.

The discharge water from the heat pump is not contaminated in any manner and can be disposed of in various way depending upon local codes.

CAUTION

Close loop and pond applications require specialized design knowledge. Do not attempt at these installations without the licensed installer the received specialized training.

APPLICATION CONTINUED

ECONOMIZER

OVERVIEW

In large commercial buildings, it is common for simultaneous heating and cooling loads to be required during the winter and shoulder seasons. In order to balance the need for different heating and cooling loads, an economizer can be used to provide “free” cooling to spaces that require it. The water-source heat pumps nearer to the exterior of the building will heat the space by extracting heat from the building’s fluid supply. The chilled fluid supply can then be used to provide cooling, by passing the fluid through the economizer coil.

FEATURES AND BENEFITS

The Hydrotech WSV6 waterside economizer option is a modular hydronic cooling coil that uses the buildings water loop to provide “free” cooling to the space. The economizer works by sensing the entering fluid temperature into the water-source heat pump and when the temperature falls below a specified set point, the system will turn off the compressor and divert the incoming chilled fluid into the economizer coil.

The ASHRAE 90.1 Energy Standard for Buildings, requires that water-source heat pumps over 54,000 BTUh of capacity be equipped with a water-side economizer. For the jurisdictions in which the ASHRAE 90.1 2019 standard is fully ratified, the Hydrotech WSV6 waterside economizer option satisfies all ASHRAE 90.1 requirements for the inclusion of an economizer on water-source heat pump units.

ECONOMIZER PERFORMANCE DATA

ECONOMIZER PERFORMANCE TABLE				
Unit	Airflow	Flowrate	Pressure Drop	Coil Pressure Drop
	SCFM	GPM	FOH	IWC
WSV6048	1200	6	1.5	0.18
	1400	9	3.3	0.22
	1600	12	5.7	0.28
WSV6060	1500	7.5	1.8	0.15
	1750	11.3	3.8	0.19
	2000	15	6.5	0.23
WSV6072	1200	9	2.5	0.21
	1400	13.5	5.3	0.27
	1600	18	9.2	0.32
NOTE: Pressure drop measured at 45° EWT				
Table 7 – Economizer Performance Data				

To ensure optimum performance of the economizer coil, it is recommended that the EWT temperature be between 40°F – 50°F. Temperatures above 50°F will limit effectiveness of the economizer coil. The electronic temperature sensor has a default set point value of 45°F.

The economizer coil adds a substantial amount of additional static pressure to the unit’s blower system. To ensure adequate airflow refer to **TABLE 7 – Economizer Performance Data**.

APPLICATION CONTINUED

HOT GAS REHEAT DEHUMIDIFICATION

OVERVIEW

Because ventilation air is introduced into buildings, indoor air quality (IAQ) and relative humidity (RH) are important issues to address in selecting heating and cooling equipment. With the Hydrotech WSV6 hot gas reheat dehumidification option, the return air from space is conditioned by a dedicated air-to-refrigerant coil and then reheated by a reheat coil to control space temperature and reduce space relative humidity. Reduced relative humidity levels also provides an improvement in indoor air quality.

ON/OFF HOT GAS REHEAT

The Hydrotech WSV6 hot gas reheat dehumidification has DDC control so the unit is BMS (BACnet MSTP) ready. Besides DDC controller, hot gas reheat dehumidification consists of a reheat coil (mounting of the air leaving side of the indoor air coil), a reheat valve, a 3-Way valve and a bleed off valve. With this hot gas reheat dehumidification option, the return air from the space is conditioned by the air-to-refrigerant indoor air coil, then reheated by the reheat coil to control not only the space temperature, but to also reduce the relative humidity of the space. The hot gas reheat dehumidification functions only during the cooling cycle.

FULL DEHUMIDIFICATION

When the space sensible temperature has been met (thermostat is satisfied) and the space relative humidity is still higher than set point (de-humidistat has not satisfied), the unit will operate in the full dehumidification mode. The reheat valve and the 3-Way valve energize, allowing the high-pressure refrigerant gas to flow from the compressor through the reversing valve, through the reheat valve and in parallel through the coaxial coil and through the 3-Way valve. Hot refrigerant from reheat valve and cool refrigerant from 3-Way valve are mixed before go through the reheat coil for dehumidification. Full dehumidification will stop when either de-humidistat has been satisfied or there is demand of space sensible temperature.

PART-LOAD DEHUMIDIFICATION

When there is demand for the space sensible temperature (thermostat is not satisfied) and the space relative humidity is still higher than set point (de-humidistat has not satisfied), the unit will operate in the part-load dehumidification mode. The reheat valve is close but the 3-Way valve energizes, allowing the high-pressure refrigerant gas to flow from the compressor into the reversing valve, through the coaxial coil and through the 3-Way valve. Cool refrigerant from 3-Way valve goes through the reheat coil for dehumidification. Part-load dehumidification will stop when de-humidistat is satisfied.

APPLICATION CONTINUED

ANTIFREEZE CORRECTION FACTORS DATA

ANTIFREEZE	ETHYLENE GLYCOL				
	10%	20%	30%	40%	50%
COOLING CAPACITY	0.995	0.992	0.987	0.983	0.979
HEATING CAPACITY	0.991	0.982	0.977	0.969	0.961
PRESSURE DROP	1.070	1.130	1.180	1.260	1.280

Table 8 - Antifreeze Correction Factors Ethylene Glycol

ANTIFREEZE	PROPYLENE GLYCOL				
	10%	20%	30%	40%	50%
COOLING CAPACITY	0.990	0.980	0.970	0.960	0.950
HEATING CAPACITY	0.987	0.975	0.962	0.942	0.930
PRESSURE DROP	1.070	1.150	1.250	1.370	1.420

Table 9 - Antifreeze Correction Factors Propylene Glycol

ANTIFREEZE	METHANOL	
	10%	20%
COOLING CAPACITY	0.980	0.972
HEATING CAPACITY	0.950	0.970
PRESSURE DROP	1.023	1.067

Table 8 - Antifreeze Correction Factors Methanol

ANTIFREEZE	ETHANOL	
	10%	20%
COOLING CAPACITY	0.991	0.951
HEATING CAPACITY	0.995	0.960
PRESSURE DROP	1.035	0.960

Table 9 - Antifreeze Correction Factors Ethanol

CONTROLS

SEQUENCE OF OPERATION

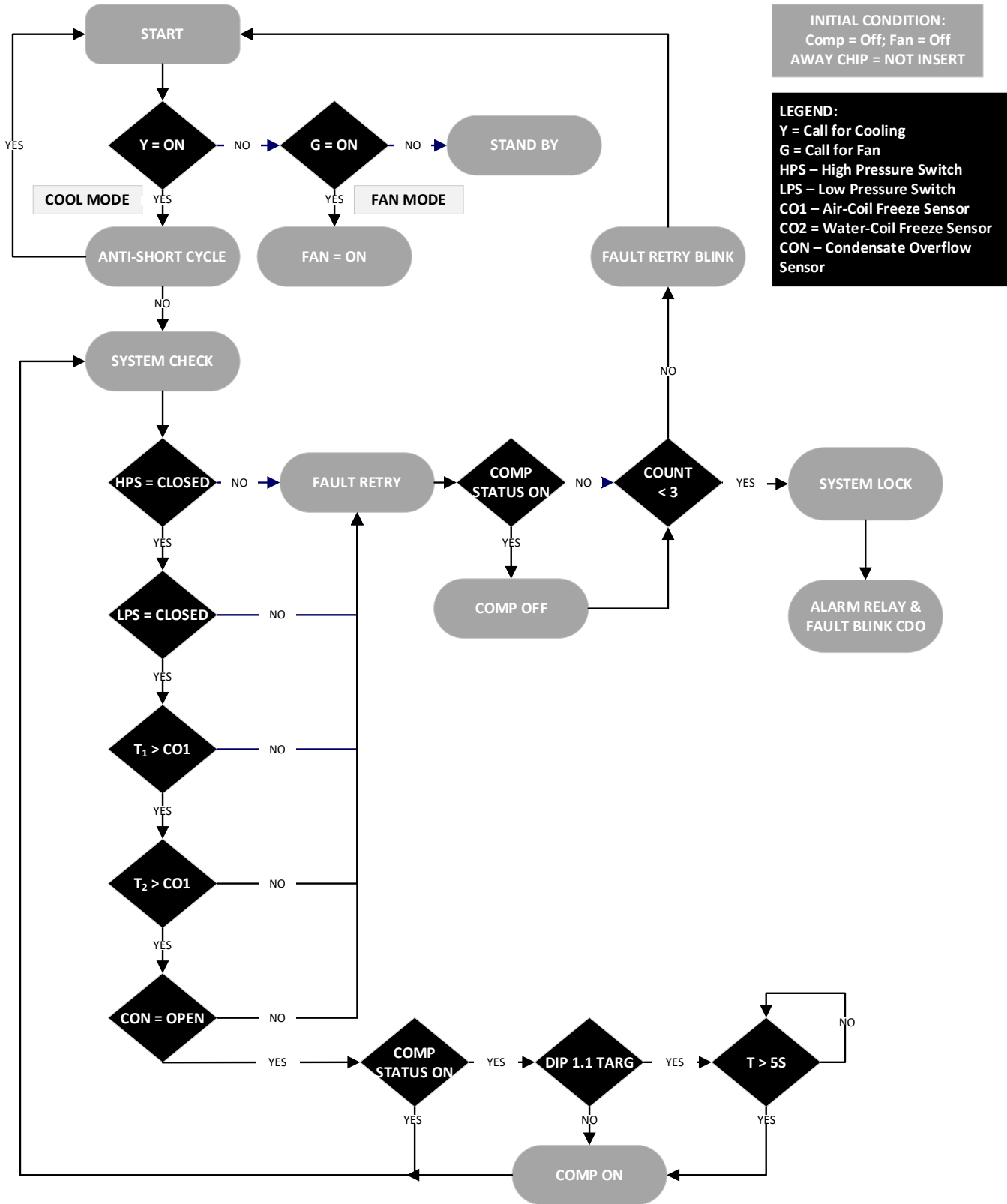

FIGURE 13 – Sequence of Operations

CONTROLS CONTINUED

WSCM CONTROL MODULE

CONTROL FEATURES

- Anti-short Cycle Protection
- Random Start
- High and low Pressure Cut-out
- Water Coil Low Temperature Cut-out
- Over/Under Voltage Protection
- Fault Retry
- Lockout with Soft and Hard Reset
- Condensate Overflow Sensor
- Diagnostic LED Display
- Test Mode
- Alarm Relay
- Accessory Relays
- Vacated Mode
- Extended Compressor Operating Monitoring

MOTOR SPEED OPERATION

An ECM blower can be driven directly from the WSCM control module. The control of the motor is based off the input signals of G, Y1, and O. The blower speed is automatically controlled via the WSCM module.

MOTOR SPEED OPERATION	
Unit Call	Fan Speed
G	G2
Y	G3
Y,O,G	G2, then G3 after 10min of run time

Table 12 – Motor Speed Operation ECM

A secondary heat exchanger (plate frame between the unit and the open cooling tower) may also be used. It is imperative that all air is eliminated from the closed loop side of the heat exchanger to prevent condenser fouling.

FIELD CONTROLLABLE FUNCTIONS

TEST MODE

The unit can be placed into test mode by shorting the test pins on the WSCM module. Once the pins are shorted, the WSCM module will enter a test mode period in which all time delays are sped up 15 times. While in test mode the yellow LED2 will light up yellow. Faults stored in memory can be cleared by entering into test mode and exiting the test mode, or by a hard reset. Test mode can be exited by shorting the test pins for approximately 3 seconds.

i
NOTE
i

Test mode will be automatically exited after a 10 minute period.

i
NOTE
i

During test mode, the control will monitor to see if CO1 and CO2 freeze thermistors are present and correctly. The controls will indicate fault code 19 if CO1 or CO2 are open, or if there is a jumper connecting across the free sensors terminals.

VACATED PREMISES CONTROL

i
NOTE
i

Optional Vacated Premise Kit option must be installed to operate in this mode.

The vacated premises operation is designed for extended periods of un-occupancy when the occupant wants the heat pump to operate in cooling mode for a predetermined cycle time to help control indoor air conditions. See Dip 1.7 for time selection (1 or 2 hours).

Additionally, the mode will store all faults seen over 24 hours in memory. If the same fault occurs for 4 consecutive days, the unit will go into a hard lockout.

The control kit consist of a rocker switch, wiring and a programmed chip that is installed on the WSCM module by a licensed contractor.

CONTROLS CONTINUED

FIELD CONTROLLABLE FUNCTIONS

HOME SELECTION

If the switch is in the HOME position the heat pump will operate in its normal mode.

AWAY SELECTION

If the switch is in the AWAY position the heat pump and thermostat are set to "COOL" mode the heat pump will operate in accordance to the thermostat setting. Additionally, the heat pump will cycle on in cooling mode for 15 minute run times either 4 or 8 times per day depending on the Dip 1.7 selection. Thermostat still has priority and will cycle the unit as needed.



NOTE



If the LED display is flashing "Ay" the thermostat is not set in cooling mode.

BOILERLESS CONTROL

The system can operate in boilerless mode by switching Dip 1.5. If CO1 goes below the setting of Dip 1.6 the compressor will be de-energized and control goes into emergency heat mode staging on "W1". The compressor will be locked out for 60 minutes to prevent nuisance cycling.

The set point for boiler less changeover temperature can be adjusted by switching Dip 1.6.

WATER-COIL LOW TEMPERATURE CUT-OUT LIMIT

Jumpers JW1-CO1 provide field selection of the temperature limit settings for CO1.

Not Clipped = 30°F

Clipped = 10°F



CAUTION



For all applications below 50°F entering water temperature, anti-freeze solution is required. Failure to follow this warning could result in heat exchanger, equipment or property damage.

ALARM RELAY SETTING

Jumper 3 (JW3 Alarm) provides field selection of alarm relay terminal AL2 to be jumpered to 24VAC or to be dry. The alarm relay is activated during lockout mode.

Not Clipped = AL2 Connected to "R"

Clipped = AL2 dry contacts (No connection)

DEHUMIDIFICATION MODE

The system can operate in Dehumidification mode by switching Dip 1.4 on the WSCM module. In this mode, the unit will run continuously in fan speed G2 when Y,O, G calls are given to the board. Dehumidification mode will not run in heating mode.

WSCM SAFETY FEATURES

ANTI-SHORT CYCLE PROTECTION

The WSCM module incorporates a 5 minute anti-short cycle protection for the compressor.

RANDOM START

The WSCM module features a 5-80s random start upon receiving a call to operate.

FAULT RETRY

While in Fault Retry Mode the LED will display a code representing retry and the fault code. The unit will initiate the Anti-short cycle timer and try to restart after the delay. If 3 consecutive faults occur without satisfying the thermostat the unit will go into hard lockout. The last fault causing the lockout will be stored in memory and displayed on the two digit LED display.

WATER-COIL LOW TEMPERATURE CUT-OUT (CO1)

The control module will recognize a CO1 fault during a compressor run cycle if:

- Thermistor temperature is below the selected set point limit.
- The thermistor temperature is rising at a rate less than 2°F per 30s time period. The CO1 input is bypassed for the first 120s of a compressor run cycle. On the second and third retry CO1 is bypassed for the initial 90s and 60s of run-time respectively.

AIR COIL LOW TEMPERATURE CUT-OUT (CO2)

The control module will recognize a CO2 fault during a compressor run cycle if:

- Thermistor temperature is below the selected set point limit.
- The thermistor temperature is rising at a rate less than 2°F per 30s time period. The CO2 input is bypassed for the first 120s of a compressor run cycle.

CONTROLS CONTINUED

WSCM SAFETY FEATURES

CONDENSATE OVERFLOW SENSOR

The condensate overflow sensor must sense overflow levels for 30 continuous second to initiate a COF fault. The condensate overflow sensor will be monitored during the compressor run cycle.

LOW PRESSURE

The low pressure switch must be open and remain open for 30 continuous seconds during the “on” cycle to be recognized as a low pressure fault. The low pressure switch input is bypassed for the initial 120s of compressor run-time.

HIGH PRESSURE

If the high-pressure switch opens at any time, the compressor relay is de-energized immediately.

LOCKOUT MODE

While in Lockout Mode the LED Display will display a code representing the lockout fault code. During this lockout the compressor relay is not energized and the alarm relay is activated.

The lockout mode can be cleared by either going into test mode or a hard reset via the power disconnect

Caution: Do not restart units in lockout mode without inspection and correction of the fault condition. Failure to do so many result in equipment damage.

EXTENDED COMPRESSOR OPERATION MONITORING

If the compressor relay has been energized for four continuous hours, control module will automatically turn off the compressor relay and the compressor will enter anti-short cycle delay before restarting. During this off period, all appropriate safety will be monitored and if the compressor demand is present, the control module will energize the compressor relay.

OVER/UNDER VOLTAGE SHUTDOWN

Should an Over/Under Voltage Condition be detected the control module will shut down. Over/Under Voltage faults cause a soft lockout and the unit will return to normal operation once normal voltage has been restored. The nominal voltage run is 18.5VAC to 31VAC. If the WSCM module is in Over/Under Voltage fault for 15 minutes, the alarm relay will activate.

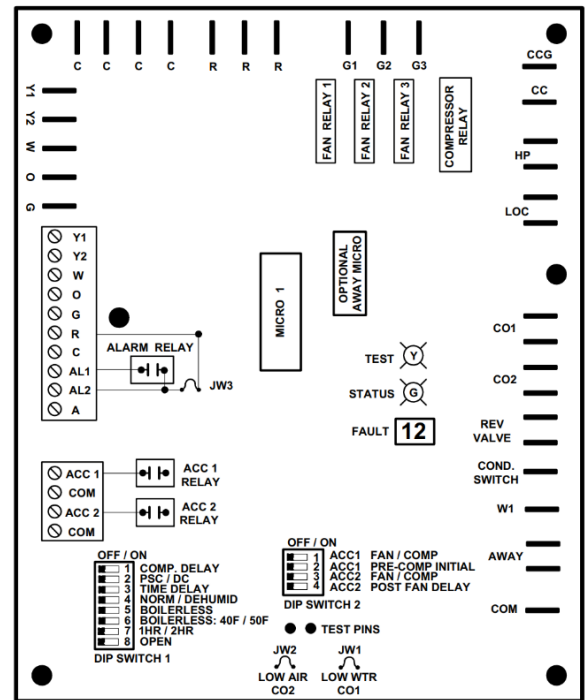

FIGURE 14 – Control Board Layout

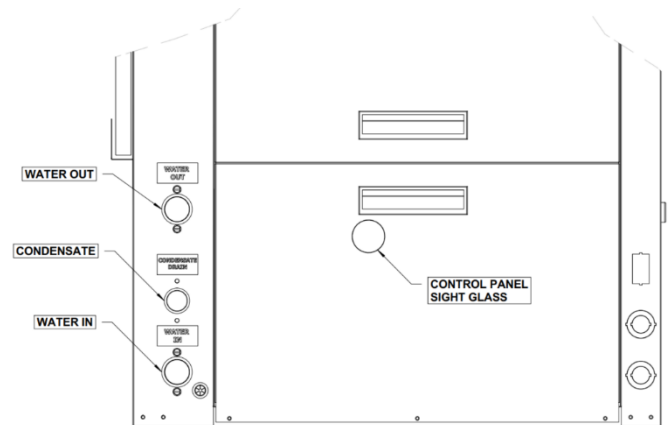

FIGURE 15 – Sight Glass Location

CONTROLS CONTINUED

ELECTRONIC TEMPERATURE CONTROLLER (ECONOMIZER)

NOTE
The electronic temperature controller must be configured prior to the initial unit start-up in order for the economizer parameters be entered.

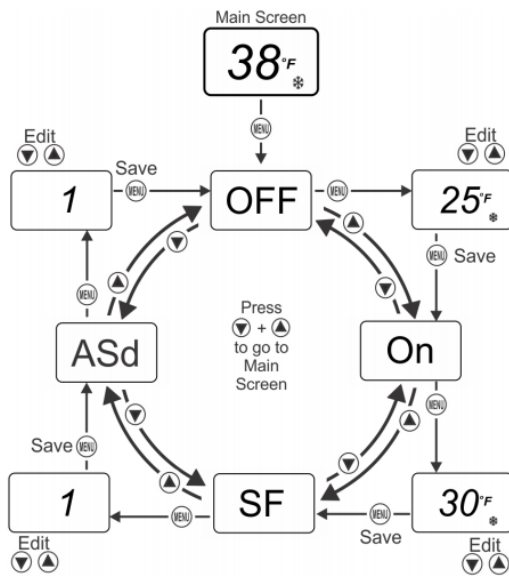

FIGURE 16 – Electronic Temperature Controller

VIEWING AND CHANGING BASIC MENU VALUES

To access the Basic menu and view and change the Basic parameter values, complete the following steps.

1. On the Main screen, press **MENU**. The LCD displays **OFF**, which is the first parameter code screen displayed in the Basic menu.
2. To scroll through all of the basic parameter codes and display the preferred code, press **Down** or **Up**.
3. With the preferred parameter code displayed, press **MENU** to display the current parameter value for the code.
4. With the current parameter value displayed, press **Down** or **Up** to scroll through all of the parameter’s usable values and display the preferred value.
5. With the preferred parameter value displayed, press **MENU** to save the displayed value and go to the next parameter code.
6. To exit the Basic menu and go to the Advanced menu, simultaneously press and hold **Down** or **Up** for 5 seconds.

ECONOMIZER PARAMETER CODES AND MODES OF OPERATION

RELAY OFF TEMPERATURE (OFF)

Select the temperature in which the 3-way valve de-energizes and the unit returns to cooling mode. Once the controller reaches the relay off temperature, the green LED on the controller will turn off. It is recommended that this temperature be set between 50-55°F.

RELAY ON TEMPERATURE (ON)

Select the temperature in which the 3-way valve energizes and the unit enters into economizer mode. Once the controller reaches the relay on temperature, the green LED on the controller will turn on. It is recommended that this temperature be set between 40-45°F.

ANTI-SHORT CYCLE DELAY (ASD)

Select the minimum time that the output relay remains off (de-energized) before the next on-cycle can begin. Setting an ASD interval overrides the output relay and prevents the 3-way valve from being energized during this time. When the ASD value is greater than 0, the delay interval will begin every time the controller turns on and every time that an off-cycle begins. It is recommended that this be set to 3.

SENSOR FAILURE MODE (SF)

Describes the functionality of the control in the event of a sensor failure. Value must be set to 0.

RECOMMENDED CONTROLLER PARAMETERS		
PARAMETER CODE	PARAMETER DESCRIPTION	RECOMMENDED PARAMETERS
Un	Relay Off Temperature	55
Off	Relay On Temperature	45
On	Anti-Short Cycle Delay	3
SO	Sensor Failure Mode	0

Table 13 – WSCM DIP Switch Functions

CONTROLS CONTINUED

WSCM SAFETY FEATURES

CONTROL BOARD LAYOUT LEGEND		
CONNECTION	INPUT OR OUTPUT	DESCRIPTION
R	--	24 VAC
C	--	24 VAC (Grounded Common)
Y1	I	Input Call for Compressor
W	I	Input Call for Heating or Emergency Heat
O	I	Input Call for Reversing Valve in Cooling
G	I	Input Call for Fan Operation
AL1	O	Connect to Thermostat Fault Light – 24VAC or Dry Contact Alarm
AL2	O	Alarm Relay 24VAC or Dry Contact
A	O	Output for Water Solenoid Valve – Paralleled with Compressor Contactor
ACC1	O	ACC1 Output for Accessory Relay 1 – 24VAC between ACC1 and COM
ACC2	O	ACC2 Output for Accessory Relay 2 – 24VAC between ACC2 and COM
G1	O	Connection for Fan Relay – Low Speed Operation
G2	O	Connection for Fan Relay – Medium Speed Operation
G3	O	Connection for Fan Relay – Large Speed Operation
CC	O	Connection for Compressor Contactor
CCG	O	Compressor Contactor Common Connections
HP	I	High Pressure Switch Input Terminals
LOC	I	Low Pressure Switch Input Terminals
CO1	I	Water Coil Low Temperature Thermistor Output
CO2	I	Air Coil Low Temperature Thermistor Output
RV	O	Reversing Valve Output Terminals – Direct Connect from “O”
COND_SW	I	Condensate Overflow Input Terminal
W1	O	Output Terminal for Electric Heat
COM	--	Grounded Common

Table 14 – Control Board Layout Legend

CONTROLLER OPERATION CODES	
DESCRIPTION OF OPERATION	LED READOUT
Normal Mode	ON (Green Light)
Controller Non Functional	OFF (Green Light)
Test Mode (pins shorted momentarily)	ON (Yellow Light)
DESCRIPTION OF OPERATION	CODE
Standby	ST
Fan Only(G active)	Fo
Cool (Y1 & O active)	Co
Heat 1st Stage (Y1 active)	H1
Accessory Relay 1	A1
Accessory Relay 2	A2
Vacated Premises Control	Ay
Fault Retry	rE & CODE #
Lockout	Lo & CODE #
Over/Under Voltage Shutdown	Ou & CODE #
Temperature Sensor Error	SE & CODE #
DESCRIPTION OF OPERATION	CODE
Test Mode – No Fault	11
Test Mode – HP Fault	12
Test Mode – LP Fault	13
Test Mode – CO1 Fault	14
Test Mode – CO2 Fault	15
Test Mode – Cond. Overflow Fault	16
Test Mode – Over/Under Shutdown	17
Test Mode – Swapped CO1/CO2 Thermistors	18

Table 15 – Control Operating Codes

CONTROLS CONTINUED

WSCM SAFETY FEATURES

WSCM DIP SWITCH FUNCTIONS			
FUNCTION		OFF	ON
DIP SWITCH 1			
1.1	Compressor Delay	No Delay	5s Delay
1.2	Motor Type	PSC Motor	ECM Motor
1.3	Blower Time Delay	None	45s
1.4	Dehumidification	None	Dehum
1.5	Boilerless	Off	On
1.6	Boilerless Setpoint	40°F	50°F
1.7	Vacated Premises	1hr	2hr
DIP SWITCH 2			
2.1	Accessory Relay Control	With Fan	With Comp
2.2	Compressor Delay	None	60s
2.3	Accessory Relay 2 Control	With Fan	With Comp
2.4	Fan Delay	None	30s

Table 16 – WSCM DIP Switch Functions

CONTROL BOX DETAIL

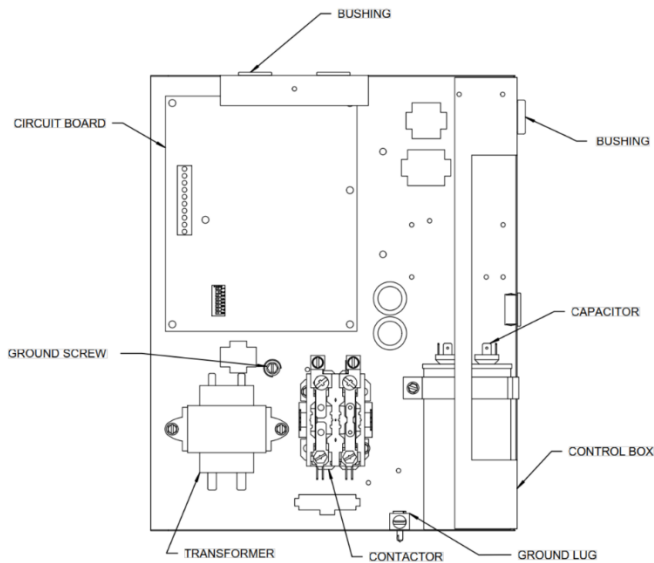

FIGURE 17 – Control Box Layout

ASSEMBLY

Once box is removed completely, line up the control panel back in place of the unit and tighten screws on the base plate and on the front panel. Plug back any harnesses previously removed.

REMOVAL

- 1) Ensure that all electrical power is removed from the unit and that the local disconnect is locked out.
- 2) Remove the screws on the front electrical panel with a ¼” hex head driver.
- 3) Remove the electrical front panel and access the electrical box
- 4) Disconnect electrical harnesses
- 5) Remove the two ¼” hex header screws holding the electrical box in place on the bottom and side.

Remove electrical box from unit.

⚠

WARNING

⚠

⚡

ELECTRIC SHOCK HAZARD

⚡

Disconnect all power supplies before servicing. Lock out/tag out to prevent accidental electrical shock.

i

NOTE

i

There may be multiple power sources supplying the unit.

PERFORMANCE DATA

BLOWER DATA

BLOWER DATA														FACTORY BLOWER SETTINGS			
MODEL NUMBER	FAN SPEED	RATED AIRFLOW	CFM VS. STATIC PRESSURE (in. w.g.)										COOLING		HEATING		
			0.1	0.2	0.3	0.4	0.5	0.6	0.7	0.8	0.9	1.0	1-10 MIN	10+ MIN			
WSV6009	WHT	330	380	360	330	300	270	250								X	X
	VIO		360	330	300	260	230							X			
	GRY		310	290	270	250											
WSV6012	WHT	430	470	450	430	400	370	340	310							X	X
	VIO		440	410	380	350	320	300						X			
	GRY		380	360	340	320	300										
WSV6018	T3	600	730	700	660	630	590	550	520							X	X
	T2		610	580	540	500	460							X			
	T1		540	510	480	450											
WSV6024	T3	800	900	870	840	810	780	750	720							X	X
	T2		760	740	710	650	610							X			
	T1		700	670	630	600											
WSV6030	T3	925	1,160	1,130	1,100	1,070	1,040	1,010	980	950	930	900				X	X
	T2		1,040	1,000	980	940	900	870	840	810				X			
	T1		940	910	870	830	800	760									
WSV6036	T3	1150	1,380	1,350	1,320	1,290	1,270	1,240	1,210	1,180	1,150	1,120				X	X
	T2		1,130	1,090	1,060	1,030	1,000	970						X			
	T1		1,060	1,030	990	960											
WSV6042	T3	1330	1,420	1,400	1,370	1,340	1,320	1,290	1,260	1,230	1,200	1,170				X	X
	T2		1,330	1,300	1,270	1,240	1,220	1,190	1,160	1,130				X			
	T1		1,190	1,160	1,130	1,100											
WSV6048	T3	1500	1,660	1,630	1,620	1,580	1,560	1,520	1,490	1,460	1,430	1,400				X	X
	T2		1,550	1,530	1,510	1,480	1,450	1,420	1,390	1,360	1,330	1,300		X			
	T1		1,370	1,350	1,330	1,290	1,260										
WSV6048 ECON	T3	1500	1,660	1,630	1,620	1,580	1,560	1,520	1,490	1,460	1,430	1,400				X	X
	T2		1,550	1,530	1,510	1,480	1,450	1,420	1,390	1,360	1,330	1,300		X			
	T1		1,370	1,350	1,330	1,290	1,260										
WSV6060	T3	1875	2,290	2,250	2,210	2,160	2,120	2,070	2,020	1,970	1,910	1,840				X	X
	T2		1,920	1,880	1,840	1,790	1,750	1,700	1,650	1,600	1,540	1,470		X			
	T1		1,820	1,780	1,730	1,690	1,640	1,590	1,550	1,490	1,440	1,370					
WSV6060 ECON	T3	1875	2,290	2,250	2,210	2,160	2,120	2,070	2,020	1,970	1,910	1,840				X	X
	T2		1,920	1,880	1,840	1,790	1,750	1,700	1,650	1,600	1,540	1,470		X			
	T1		1,820	1,780	1,730	1,690	1,640	1,590	1,550	1,490	1,440	1,370					
WSV6072	T3	1900	2,290	2,250	2,210	2,160	2,120	2,070	2,020	1,970	1,910	1,840				X	X
	T2		2,140	2,100	2,060	2,010	1,970	1,920	1,870	1,820	1,760	1,690		X			
	T1		1,990	1,950	1,910	1,860	1,820	1,770	1,720	1,670	1,610	1,540					
WSV6072 ECON	T3	1900	2,290	2,250	2,210	2,160	2,120	2,070	2,020	1,970	1,910	1,840				X	X
	T2		2,140	2,100	2,060	2,010	1,970	1,920	1,870	1,820	1,760	1,690		X			
	T1		1,990	1,950	1,910	1,860	1,820	1,770	1,720	1,670	1,610	1,540					

Airflow data shown is with a dry coil at 70°F DB EAT and with standard 1" filter.

Table 17 – WSV6 Blower Data

PERFORMANCE DATA CONTINUED

PRESSURE & TEMPERATURE DATA

WSV6009 PRESSURE & TEMPERATURE DATA									
Entering Water Temp	Water Flow Rate	COOLING				HEATING			
		Suction Pressure	Discharge Pressure	Air Temp Drop	Water Temp Rise	Suction Pressure	Discharge Pressure	Air Temp Drop	Water Temp Rise
°F	GPM	psig	psig	°F	°F	psig	psig	°F	°F
20	1.1	Operation Not Recommended				Operation Not Recommended			
	1.7								
	2.3								
30	1.1					61-71	258-268	17-23	7-11
	1.7					62-72	262-272	18-24	5-9
	2.3					63-73	264-274	18-24	3-7
50	1.1	128-138	214-224	22-28	21-25	83-93	290-300	22-28	9-13
	1.7	137-147	193-203	22-28	13-17	90-100	296-206	24-30	6-10
	2.3	126-136	183-193	22-28	10-14	93-103	299-309	24-30	4-8
70	1.1	132-142	284-294	21-27	20-24	118-128	324-334	29-35	13-17
	1.7	130-140	260-270	21-27	13-17	120-130	335-345	30-36	9-13
	2.3	130-140	249-259	21-27	9-13	144-154	340-350	32-38	6-10
90	1.1	135-145	367-377	19-25	19-23	159-169	373-383	37-43	17-21
	1.7	134-144	342-352	20-26	12-16	175-185	383-393	39-45	12-16
	2.3	134-144	330-340	20-26	9-13	184-194	392-402	41-47	9-13
110	1.1	142-152	468-478	18-24	18-22	Operation Not Recommended			
	1.7	140-150	442-452	18-24	12-16				
	2.3	139-149	430-440	19-25	8-12				

Table 18 – WSV6009 Pressure & Temperature Data

PERFORMANCE DATA CONTINUED

PRESSURE & TEMPERATURE DATA

WSV6012 PRESSURE & TEMPERATURE DATA									
Entering Water Temp	Water Flow Rate	COOLING				HEATING			
		Suction Pressure	Discharge Pressure	Air Temp Drop	Water Temp Rise	Suction Pressure	Discharge Pressure	Air Temp Drop	Water Temp Rise
°F	GPM	psig	psig	°F	°F	psig	psig	°F	°F
20	1.5	Operation Not Recommended				Operation Not Recommended			
	2.3								
	3								
30	1.5					59-69	263-273	16-22	7-11
	2.3					64-57	268-278	17-23	4-8
	3					68-78	270-280	18-24	3-7
50	1.5	126-136	215-225	20-26	21-25	85-95	296-306	22-28	9-13
	2.3	125-135	194-204	21-27	13-17	92-102	303-313	23-29	6-10
	3	124-134	183-193	21-27	9-13	95-105	306-316	24-30	4-8
70	1.5	130-140	284-294	19-25	20-24	121-131	334-344	29-35	13-17
	2.3	128-138	260-270	20-26	13-17	131-141	345-355	31-37	8-12
	3	128-138	248-258	20-26	9-13	137-147	358-368	32-38	6-10
90	1.5	134-144	366-376	18-24	20-24	163-173	383-393	37-43	16-20
	2.3	133-143	341-351	19-25	13-17	179-189	401-411	40-46	11-15
	3	132-142	328-338	19-25	9-13	188-198	412-422	42-48	8-12
110	1.5	139-149	466-476	17-23	19-23	Operation Not Recommended			
	2.3	138-148	439-449	17-23	12-16				
	3	137-147	426-436	17-23	9-13				

Table 19 – WSV6012 Pressure & Temperature Data

PERFORMANCE DATA CONTINUED

PRESSURE & TEMPERATURE DATA

WSV6018 PRESSURE & TEMPERATURE DATA									
Entering Water Temp	Water Flow Rate	COOLING				HEATING			
		Suction Pressure	Discharge Pressure	Air Temp Drop	Water Temp Rise	Suction Pressure	Discharge Pressure	Air Temp Drop	Water Temp Rise
°F	GPM	psig	psig	°F	°F	psig	psig	°F	°F
20	2.3	Operation Not Recommended				Operation Not Recommended			
	3.4								
	4.5								
30	2.3					62-72	276-286	16-22	7-11
	3.4					65-75	282-292	17-23	5-9
	4.5					70-80	283-293	18-24	3-7
50	2.3	124-134	212-222	19-25	17-21	95-105	334-344	24-30	9-13
	3.4	123-133	194-204	20-26	11-15	103-113	344-354	26-32	6-10
	4.5	122-132	186-196	20-26	8-12	107-117	360-360	27-33	4-8
70	2.3	128-138	282-292	18-24	17-21	132-142	383-393	31-37	12-16
	3.4	127-137	262-272	19-25	10-14	143-153	399-409	33-39	8-12
	4.5	126-136	253-263	19-25	7-11	150-160	408-418	35-41	6-10
90	2.3	132-142	367-377	18-24	16-20	178-188	444-454	39-45	16-20
	3.4	131-141	346-356	18-24	10-14	195-205	466-476	42-48	10-14
	4.5	131-141	338-348	18-24	7-11	205-215	479-489	43-49	8-12
110	2.3	137-147	471-481	16-22	16-20	Operation Not Recommended			
	3.4	136-146	449-459	17-23	10-14				
	4.5	136-146	442-452	17-23	7-11				

Table 20 – WSV6018 Pressure & Temperature Data

PERFORMANCE DATA CONTINUED

PRESSURE & TEMPERATURE DATA

WSV6024 PRESSURE & TEMPERATURE DATA									
Entering Water Temp	Water Flow Rate	COOLING				HEATING			
		Suction Pressure	Discharge Pressure	Air Temp Drop	Water Temp Rise	Suction Pressure	Discharge Pressure	Air Temp Drop	Water Temp Rise
°F	GPM	psig	psig	°F	°F	psig	psig	°F	°F
20	3	Operation Not Recommended				Operation Not Recommended			
	4.5								
	6								
30	3					56-66	253-263	16-22	6-10
	4.5					61-71	256-266	17-23	4-8
	6					66-76	259-269	18-24	2-6
50	3	126-136	202-212	20-26	16-20	93-103	294-204	19-25	7-11
	4.5	125-135	187-197	20-26	10-14	98-108	300-310	20-26	5-9
	6	113-123	180-190	20-26	8-12	102-112	303-313	21-27	3-7
70	3	130-140	271-281	19-25	16-20	130-140	330-340	26-32	11-15
	4.5	129-139	255-265	19-25	10-14	140-150	339-349	27-33	7-11
	6	129-139	247-257	19-25	7-11	145-155	344-354	28-34	5-9
90	3	135-145	357-367	18-24	15-19	176-186	385-395	33-39	14-18
	4.5	134-144	340-350	18-24	10-14	191-201	388-398	35-41	9-13
	6	133-143	331-341	18-24	7-11	199-209	407-417	37-43	7-11
110	3	140-150	461-471	17-23	15-19	Operation Not Recommended			
	4.5	139-149	443-453	17-23	9-13				
	6	139-149	434-444	17-23	7-11				

Table 21 – WSV6024 Pressure & Temperature Data

PERFORMANCE DATA CONTINUED

PRESSURE & TEMPERATURE DATA

WSV6030 PRESSURE & TEMPERATURE DATA													
Entering Water Temp	Water Flow Rate	COOLING				HEATING							
		Suction Pressure	Discharge Pressure	Air Temp Drop	Water Temp Rise	Suction Pressure	Discharge Pressure	Air Temp Drop	Water Temp Rise				
°F	GPM	psig	psig	°F	°F	psig	psig	°F	°F				
20	3.8	Operation Not Recommended				Operation Not Recommended							
	5.6												
	7.5												
30	3.8					Operation Not Recommended				53-73	264-274	19-25	7-11
	5.6									67-77	267-277	20-26	4-8
	7.5									71-81	271-281	21-27	3-7
50	3.8	118-128	218-228	24-30	20-24					93-103	309-319	26-32	9-13
	5.6	116-126	198-208	25-31	13-17					100-110	317-327	27-33	6-10
	7.5	116-126	188-198	25-31	9-13					104-114	321-331	28-34	4-8
70	3.8	123-133	289-299	23-29	20-24	130-140	349-359	33-39	12-16				
	5.6	121-131	265-275	23-29	13-17	140-150	361-371	36-42	8-12				
	7.5	120-130	254-264	23-29	9-13	147-157	368-378	37-43	6-10				
90	3.8	128-138	375-385	22-28	19-23	173-183	398-408	42-48	16-20				
	5.6	126-136	349-359	22-28	12-16	189-199	416-426	45-51	11-15				
	7.5	126-136	337-347	22-28	9-13	199-209	427-437	46-52	8-12				
110	3.8	134-144	478-488	20-26	18-22	Operation Not Recommended							
	5.6	133-143	452-462	20-26	12-16								
	7.5	132-142	439-449	21-27	8-12								

Table 22 – WSV6030 Pressure & Temperature Data

PERFORMANCE DATA CONTINUED

PRESSURE & TEMPERATURE DATA

WSV6036 PRESSURE & TEMPERATURE DATA									
Entering Water Temp	Water Flow Rate	COOLING				HEATING			
		Suction Pressure	Discharge Pressure	Air Temp Drop	Water Temp Rise	Suction Pressure	Discharge Pressure	Air Temp Drop	Water Temp Rise
°F	GPM	psig	psig	°F	°F	psig	psig	°F	°F
20	4.5	Operation Not Recommended				Operation Not Recommended			
	6.8								
	9								
30	4.5					62-72	265-275	19-25	7-11
	6.8					66-76	269-279	20-26	4-8
	9					70-80	275-285	21-27	2-6
50	4.5	122-132	221-231	23-29	19-23	93-103	311-321	25-31	9-13
	6.8	120-130	203-213	23-29	12-16	100-110	319-329	26-32	6-10
	9	120-130	194-204	23-29	9-13	104-114	323-333	27-33	4-8
70	4.5	126-136	294-304	22-28	19-23	130-140	353-363	32-38	13-17
	6.8	125-135	273-283	22-28	12-16	141-151	365-375	34-40	8-12
	9	124-134	264-274	22-28	9-13	148-158	373-383	36-42	6-10
90	4.5	131-141	382-392	21-27	18-22	175-185	403-413	41-47	16-20
	6.8	129-139	360-370	21-27	12-16	192-202	421-431	43-49	11-15
	9	129-139	350-360	21-27	8-12	202-212	432-442	45-61	8-12
110	4.5	136-146	489-499	19-25	18-22	Operation Not Recommended			
	6.8	135-145	466-476	20-26	11-15				
	9	135-145	457-467	20-26	8-12				

Table 23 – WSV6036 Pressure & Temperature Data

PERFORMANCE DATA CONTINUED

PRESSURE & TEMPERATURE DATA

WSV6042 PRESSURE & TEMPERATURE DATA									
Entering Water Temp	Water Flow Rate	COOLING				HEATING			
		Suction Pressure	Discharge Pressure	Air Temp Drop	Water Temp Rise	Suction Pressure	Discharge Pressure	Air Temp Drop	Water Temp Rise
°F	GPM	psig	psig	°F	°F	psig	psig	°F	°F
20	5.3	Operation Not Recommended				Operation Not Recommended			
	7.9								
	10.5								
30	5.3					58-68	262-272	19-25	5-9
	7.9					62-72	266-276	20-26	3-7
	10.5					64-74	271-281	21-27	2-6
50	5.3	128-138	226-236	24-30	20-24	89-99	293-303	24-30	8-12
	7.9	127-137	205-215	25-31	13-17	95-105	299-309	25-31	5-9
	10.5	126-136	195-205	25-31	9-13	99-109	302-312	26-32	3-7
70	5.3	133-143	298-308	23-29	19-23	126-136	328-338	31-37	11-15
	7.9	131-141	274-284	24-30	12-16	134-144	336-346	33-39	8-12
	10.5	131-141	263-273	24-30	9-13	141-151	343-353	34-40	5-9
90	5.3	137-147	385-395	22-28	18-22	170-180	372-382	39-45	15-19
	7.9	136-146	359-369	22-28	12-16	185-195	387-397	42-48	10-14
	10.5	135-145	348-358	23-29	8-12	194-204	395-405	43-50	7-11
110	5.3	143-153	489-499	21-27	18-22	Operation Not Recommended			
	7.9	141-151	463-473	21-27	11-15				
	10.5	141-151	451-461	21-27	8-12				

Table 23 – WSV6042 Pressure & Temperature Data

PERFORMANCE DATA CONTINUED

PRESSURE & TEMPERATURE DATA

WSV6048 PRESSURE & TEMPERATURE DATA									
Entering Water Temp	Water Flow Rate	COOLING				HEATING			
		Suction Pressure	Discharge Pressure	Air Temp Drop	Water Temp Rise	Suction Pressure	Discharge Pressure	Air Temp Drop	Water Temp Rise
°F	GPM	psig	psig	°F	°F	psig	psig	°F	°F
20	6	Operation Not Recommended				Operation Not Recommended			
	9								
	12								
30	6	Operation Not Recommended				65-75	271-281	19-25	7-11
	9					69-79	275-285	20-26	4-8
	12					73-83	280-290	21-27	3-7
50	6	122-132	222-232	24-30	20-24	104-114	310-320	25-31	9-13
	9	120-130	201-211	25-31	13-17	111-121	316-326	26-32	5-9
	12	120-130	191-201	25-31	9-13	115-125	320-330	27-33	4-8
70	6	127-137	293-303	23-29	20-24	144-154	348-358	32-38	12-16
	9	125-135	269-279	23-29	13-17	155-165	359-369	34-40	8-12
	12	124-134	257-267	24-30	9-13	161-171	365-375	35-41	5-9
90	6	132-142	380-390	22-28	19-23	193-203	395-405	40-46	15-19
	9	130-140	354-364	22-28	12-16	209-219	411-421	42-48	10-14
	12	129-139	341-351	22-28	9-13	217-227	420-430	43-50	7-11
110	6	138-148	485-495	21-27	18-22	Operation Not Recommended			
	9	136-146	457-467	21-27	12-16				
	12	135-145	444-454	21-27	8-12				

Table 24 – WSV6048 Pressure & Temperature Data

PERFORMANCE DATA CONTINUED

PRESSURE & TEMPERATURE DATA

WSV6060 PRESSURE & TEMPERATURE DATA													
Entering Water Temp	Water Flow Rate	COOLING				HEATING							
		Suction Pressure	Discharge Pressure	Air Temp Drop	Water Temp Rise	Suction Pressure	Discharge Pressure	Air Temp Drop	Water Temp Rise				
°F	GPM	psig	psig	°F	°F	psig	psig	°F	°F				
20	7.5	Operation Not Recommended				Operation Not Recommended							
	11.3												
	15												
30	7.5					Operation Not Recommended				58-68	265-275	25-31	7-11
	11.3									62-72	269-279	26-32	4-8
	15									64-74	274-284	27-33	3-7
50	7.5	125-135	220-230	25-31	19-23					91-101	309-319	28-34	9-13
	11.3	123-133	201-211	25-31	12-16					98-108	316-326	29-35	5-9
	15	123-133	191-201	25-31	9-13					101-111	320-330	30-36	4-8
70	7.5	129-139	290-300	24-30	18-22	128-138	349-359	36-42	12-16				
	11.3	128-138	268-278	24-30	12-16	138-148	361-371	38-44	8-12				
	15	127-137	257-267	24-30	8-12	144-154	367-377	39-45	5-9				
90	7.5	134-144	377-387	23-29	18-22	172-182	398-408	45-51	15-19				
	11.3	133-143	352-362	23-29	11-15	187-197	415-425	48-54	10-14				
	15	132-142	340-350	23-29	8-12	196-206	424-434	50-56	7-11				
110	7.5	140-150	480-490	21-27	17-21	Operation Not Recommended							
	11.3	139-149	455-465	21-27	11-15								
	15	138-148	443-453	22-28	8-12								

Table 25 – WSV6060 Pressure & Temperature Data

PERFORMANCE DATA CONTINUED

PRESSURE & TEMPERATURE DATA

WSV6072 PRESSURE & TEMPERATURE DATA													
Entering Water Temp	Water Flow Rate	COOLING				HEATING							
		Suction Pressure	Discharge Pressure	Air Temp Drop	Water Temp Rise	Suction Pressure	Discharge Pressure	Air Temp Drop	Water Temp Rise				
°F	GPM	psig	psig	°F	°F	psig	psig	°F	°F				
20	9	Operation Not Recommended				Operation Not Recommended							
	13.5												
	18												
30	9					56-66	275-285	20-26	5-9				
	13.5					59-69	281-291	22-28	3-7				
	18					64-74	283-293	23-29	2-6				
50	9					122-132	219-229	25-31	18-22	85-95	309-319	28-34	8-12
	13.5					121-131	202-212	26-32	12-16	91-101	316-326	29-35	5-9
	18					120-130	193-203	26-32	8-12	95-105	320-330	30-36	3-7
70	9					126-136	288-298	24-30	18-22	119-129	351-361	36-42	11-15
	13.5	125-135	268-278	24-30	11-15	129-139	363-373	38-44	7-11				
	18	125-135	259-269	25-31	8-12	135-145	370-380	40-46	5-9				
90	9	132-142	373-383	23-29	17-21	160-170	403-413	46-52	14-18				
	13.5	130-140	351-361	23-29	11-15	175-185	422-432	49-55	10-14				
	18	130-140	341-351	23-29	8-12	184-194	433-443	51-57	7-11				
110	9	137-147	474-484	21-27	17-21	Operation Not Recommended							
	13.5	136-146	451-461	22-28	11-15								
	18	135-145	441-451	22-28	8-12								

Table 26 – WSV6072 Pressure & Temperature Data

PERFORMANCE DATA CONTINUED

WATER PRESSURE DROP DATA

WATER FLOW PRESSURE DROP DATA								
WSV6009	Flow Rate (GPM)	1.0	2.0	3.0	4.0	5.0	6.0	7.0
	Pressure Drop	0.2	0.9	1.9	3.0	4.5	6.3	8.2
WSV6012	Flow Rate (GPM)	2.0	3.0	4.0	5.0	6.0	7.0	8.0
	Pressure Drop	1.0	2.0	3.3	4.8	6.6	8.7	10.9
WSV6018	Flow Rate (GPM)	2.0	3.0	4.0	5.0	6.0	7.0	8.0
	Pressure Drop	1.0	2.0	3.3	4.8	6.6	8.7	10.9
WSV6024	Flow Rate (GPM)	5.0	6.0	7.0	8.0	9.0	10.0	11.0
	Pressure Drop	1.4	2.0	2.6	3.3	4.1	5.0	6.0
WSV6030	Flow Rate (GPM)	6.0	7.0	8.0	9.0	10.0	11.0	12.0
	Pressure Drop	2.3	3.0	3.9	4.8	5.8	6.9	8.0
WSV6036	Flow Rate (GPM)	6.0	8.0	10.0	12.0	14.0	16.0	18.0
	Pressure Drop	1.1	1.9	2.8	4.0	5.2	6.7	8.2
WSV6042	Flow Rate (GPM)	7.0	9.0	11.0	13.0	15.0	17.0	19.0
	Pressure Drop	1.4	2.1	3.0	4.1	5.2	6.6	8.0
WSV6048	Flow Rate (GPM)	12.0	14.0	16.0	18.0	20.0		
	Pressure Drop	2.6	3.5	4.7	5.9	7.4		
WSV6048 ECONOMIZER	Flow Rate (GPM)	12.0	14.0	16.0	18.0	20.0		
	Pressure Drop	6.5	8.8	11.8	14.8	18.5		
WSV6060	Flow Rate (GPM)	12.0	14.0	16.0	18.0	20.0	22.0	24.0
	Pressure Drop	2.6	3.3	4.2	5.1	6.2	7.3	8.5
WSV6060 ECONOMIZER	Flow Rate (GPM)	12.0	14.0	16.0	18.0	20.0	22.0	24.0
	Pressure Drop	6.0	8.2	10.6	13.4	16.5	19.9	23.7
WSV6072	Flow Rate (GPM)	12.0	14.0	16.0	18.0	20.0	22.0	24.0
	Pressure Drop	2.6	3.3	4.2	5.1	6.2	7.3	8.5
WSV6072 ECONOMIZER	Flow Rate (GPM)	12.0	14.0	16.0	18.0	20.0	22.0	24.0
	Pressure Drop	6.0	8.2	10.6	13.4	16.5	19.9	23.7

Table 27 – Pressure Drop Data

WIRING DIAGRAMS

WSV6009-12 WIRING DIAGRAM (208-230V)

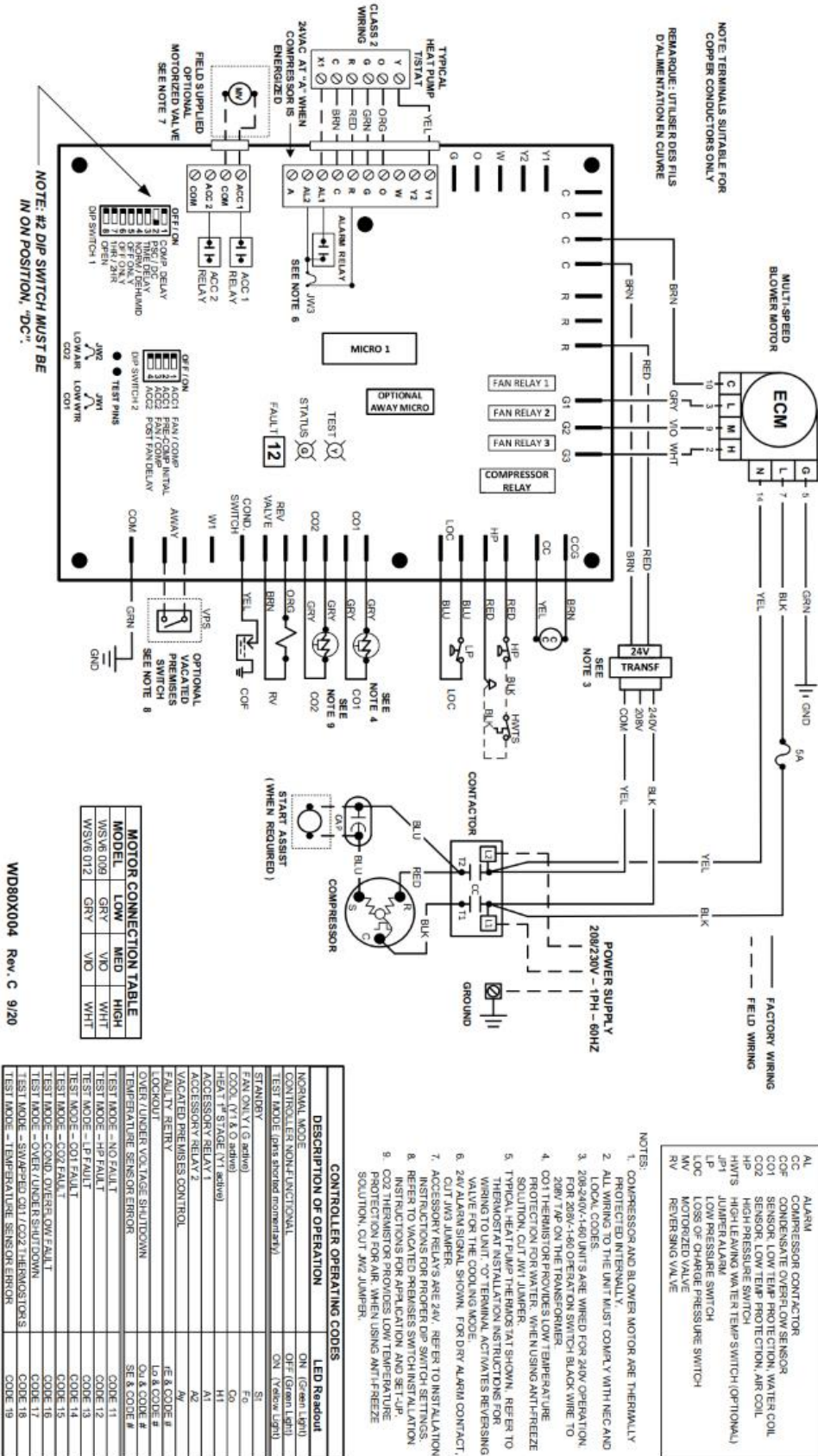

FIGURE 18 – WSV6009-12 (208-230V)* Wiring Diagram

WIRING DIAGRAMS

WSV6009-12 WIRING DIAGRAM (265V)

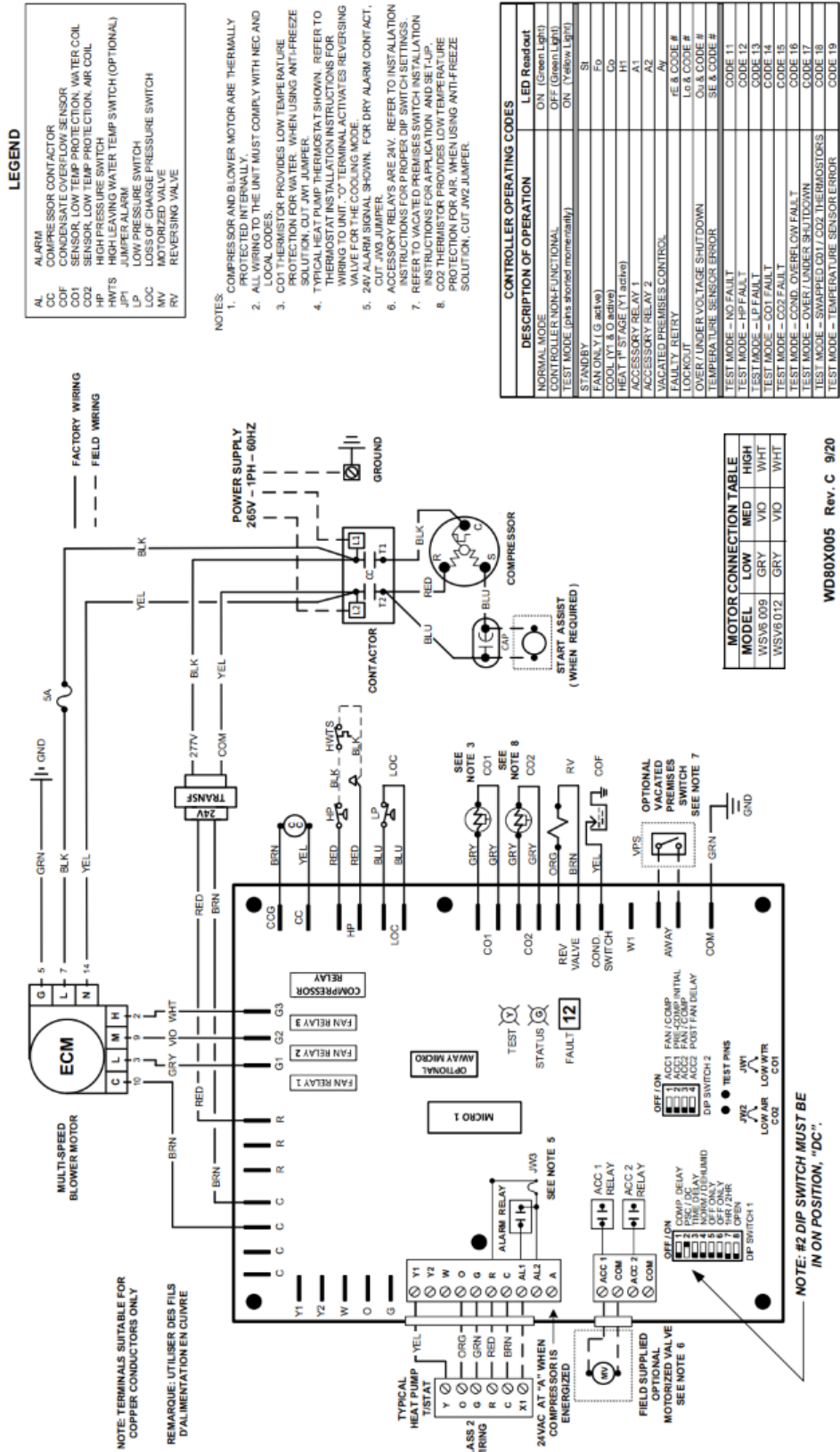

FIGURE 19 – WSV6009-12 (265V) Wiring Diagram

wiring diagrams

WIRING DIAGRAMS

WSV6018-72 WIRING DIAGRAM (208-230V)

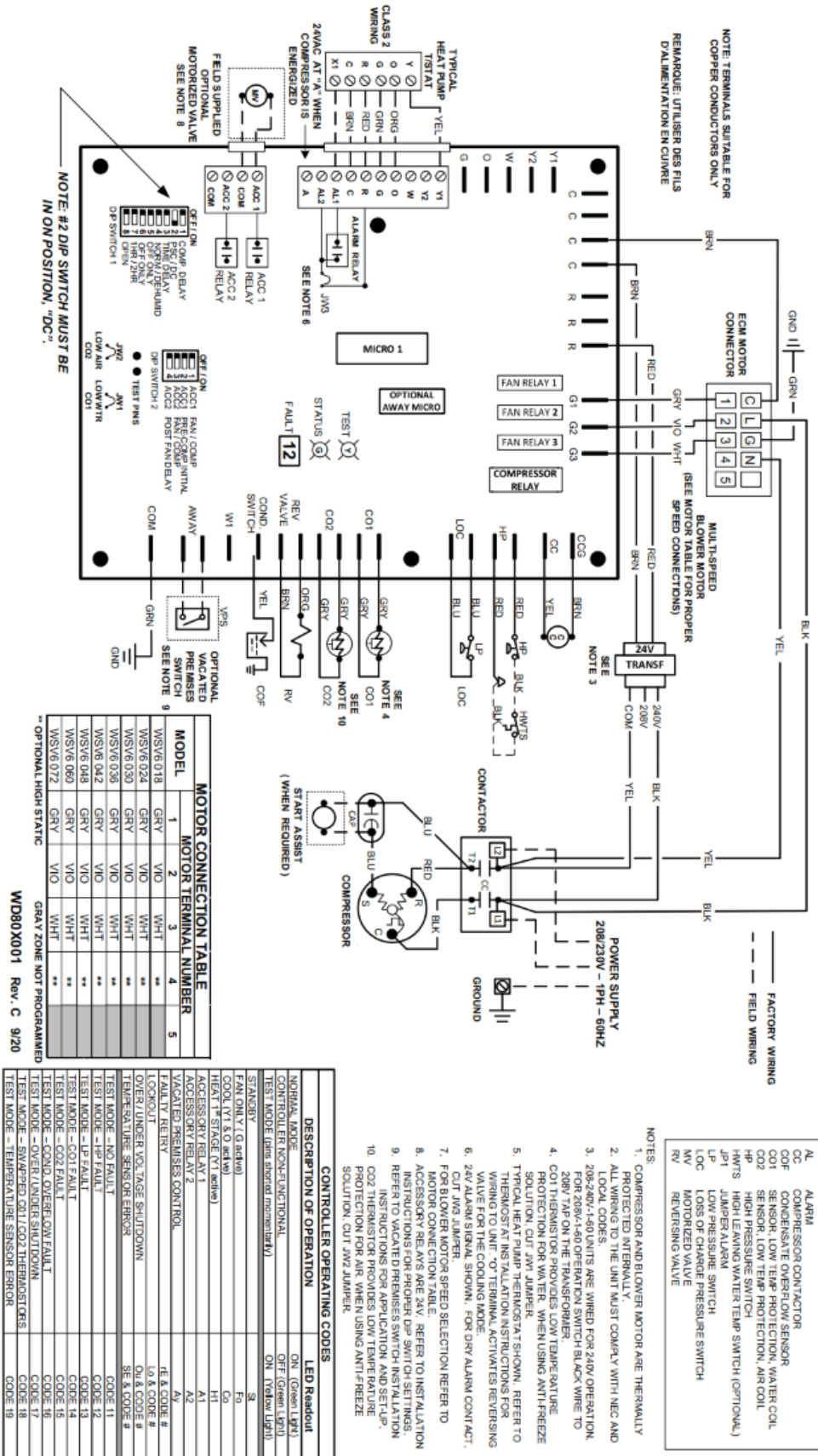

FIGURE 20 - WSV6018-72 (208-230V) Wiring Diagram

WIRING DIAGRAMS

WSV6018-72 WIRING DIAGRAM (265V)

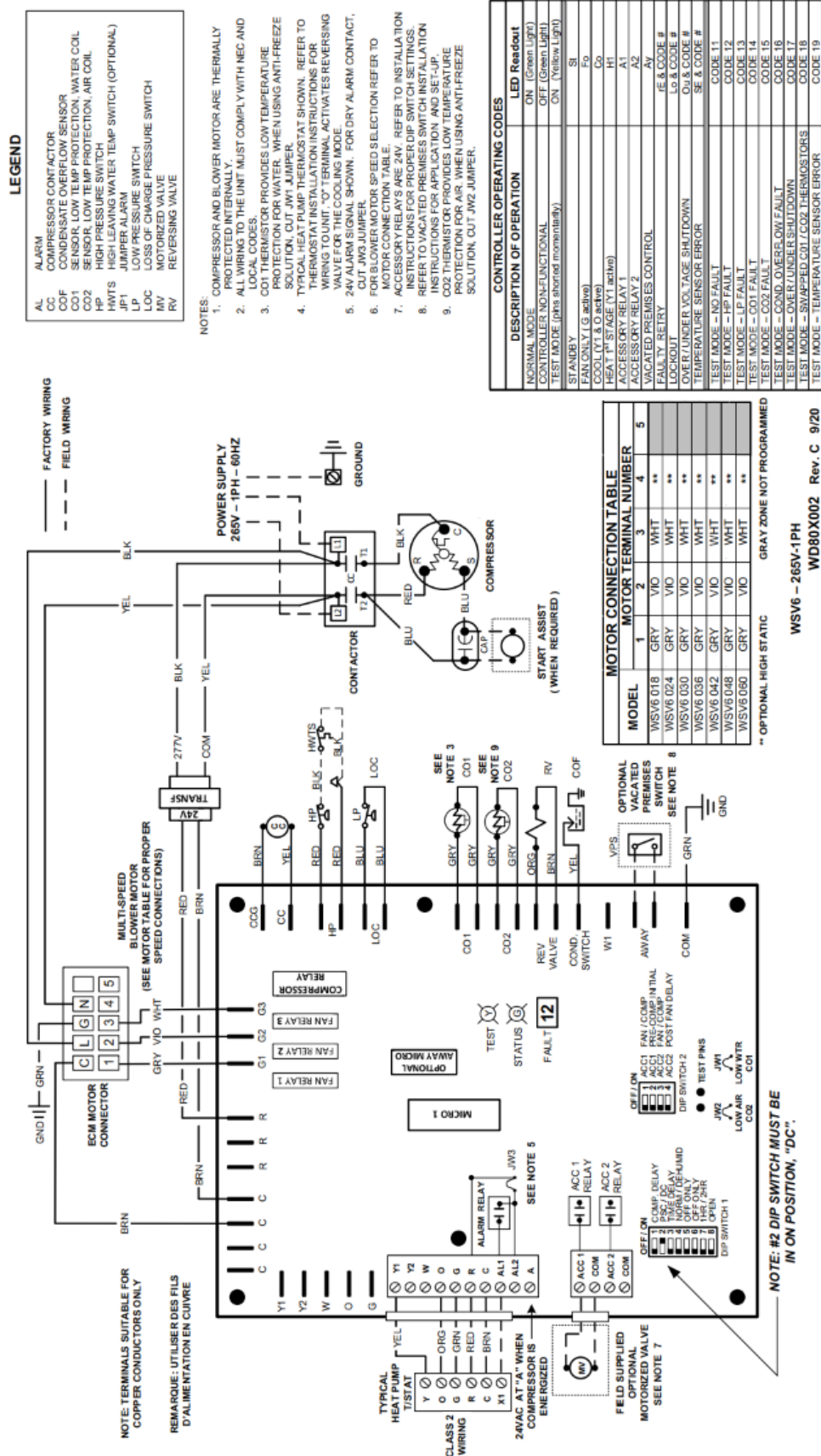

FIGURE 21 – WSV6018-72 (265V) Wiring Diagram

WIRING DIAGRAMS

WSV6024-72 WIRING DIAGRAM (208-230-460V / 3Ph)

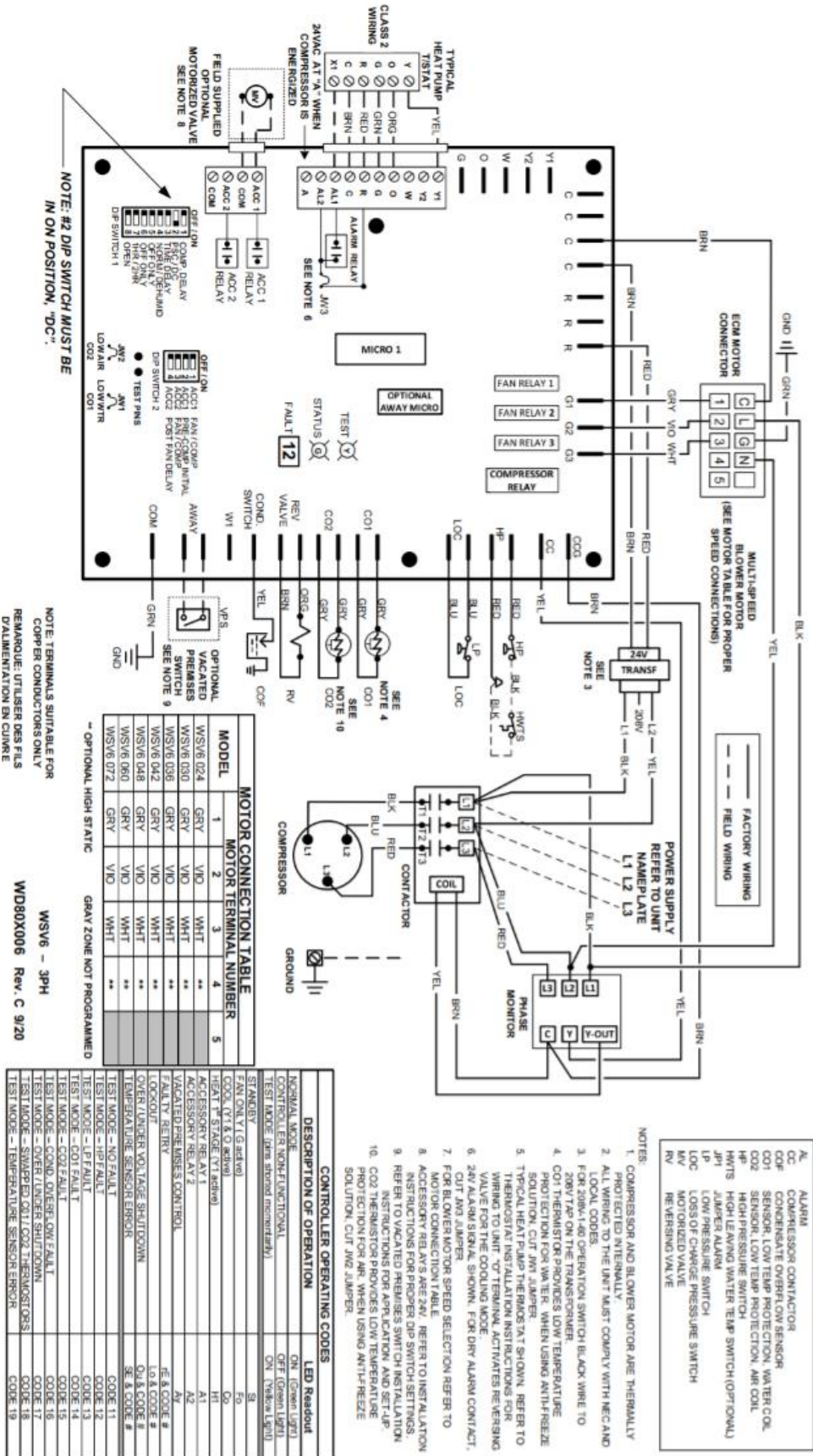

FIGURE 22 – WSV6024-72 (208-230-460V / 3Ph) Wiring Diagram

WIRING DIAGRAMS

WSV6048-72 ECONOMIZER WIRING DIAGRAM (208-230V)

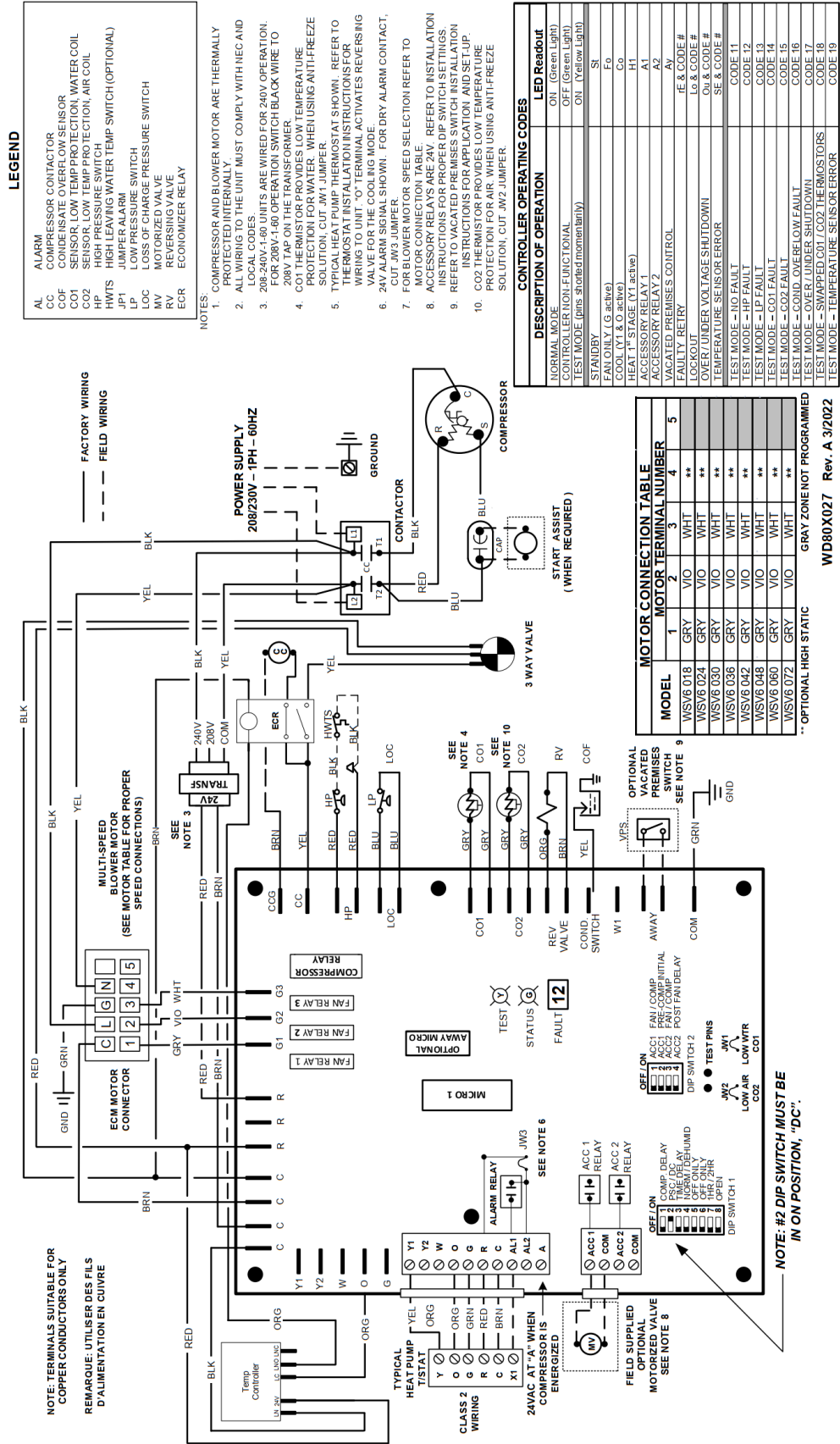

FIGURE 23 – WSV6048-72 ECONOMIZER (208-230V) Wiring Diagram

WIRING DIAGRAMS

WSV6048-72 ECONOMIZER WIRING DIAGRAM (208-230-460V / 3PH)

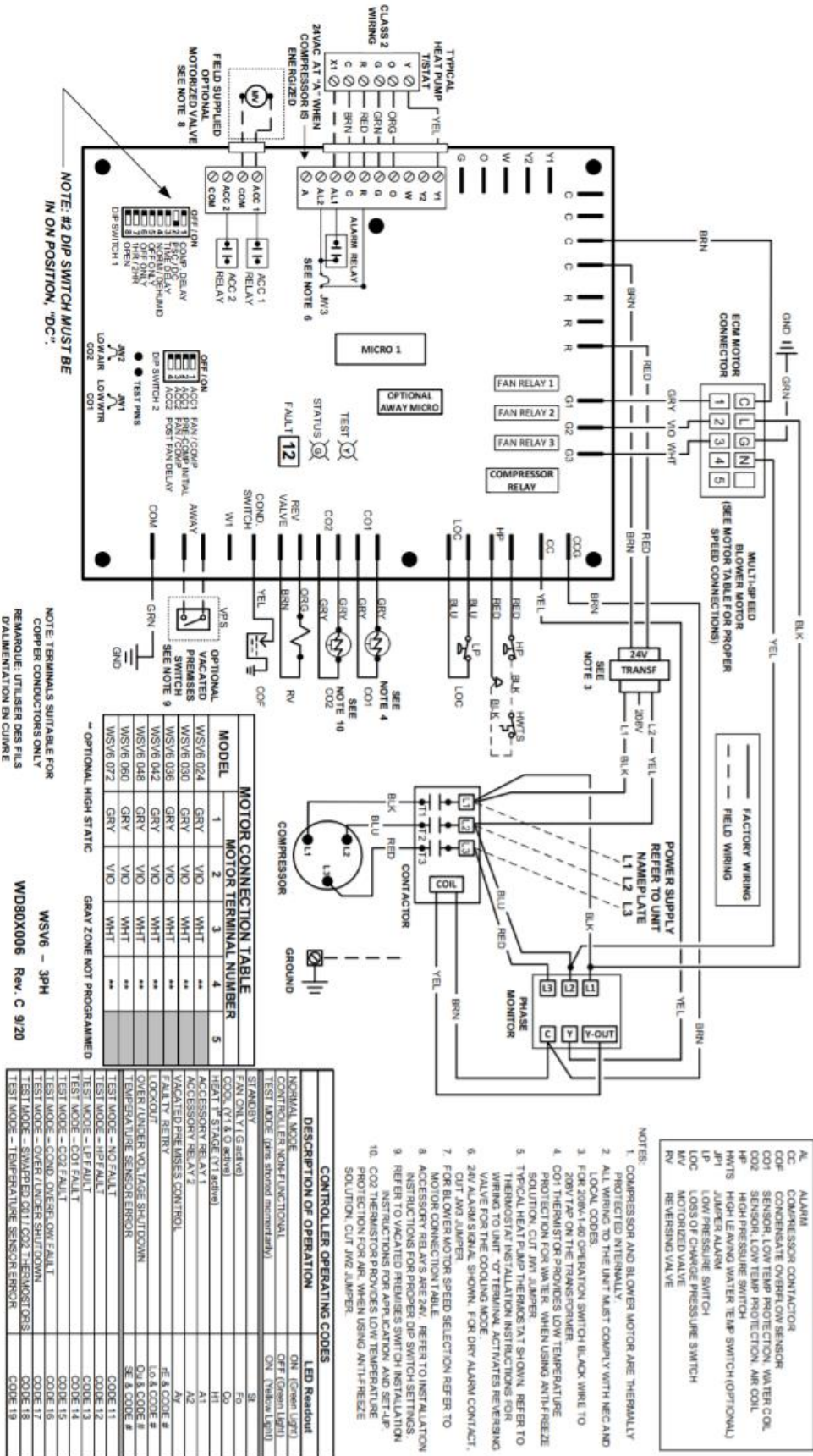

FIGURE 24 – WSV6048-72 ECONOMIZER (208-230-460V / 3Ph) Wiring Diagram

CIRCUIT SCHEMATIC

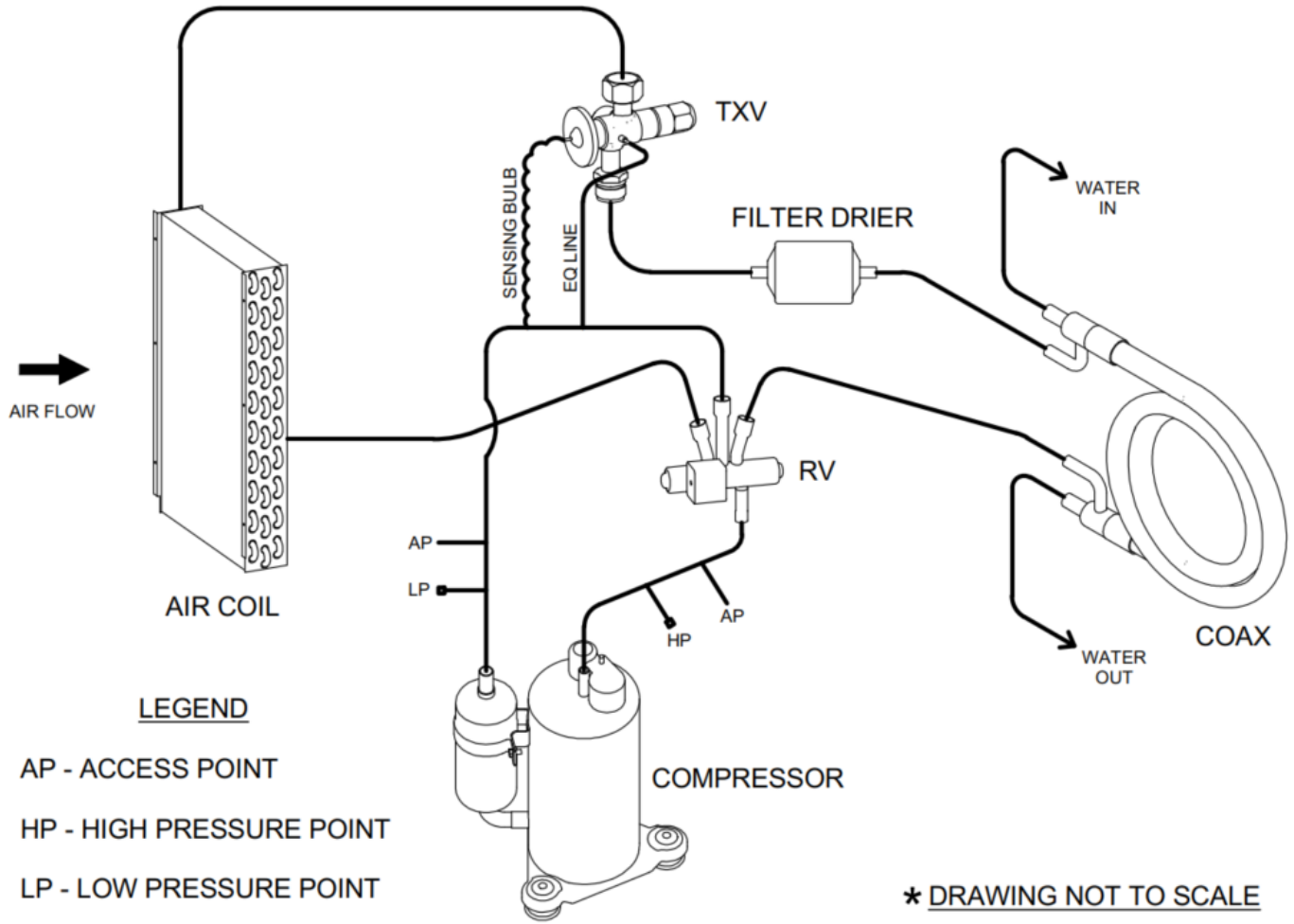

FIGURE 25 - Circuit Diagram

CIRCUIT SCHEMATIC HGRH

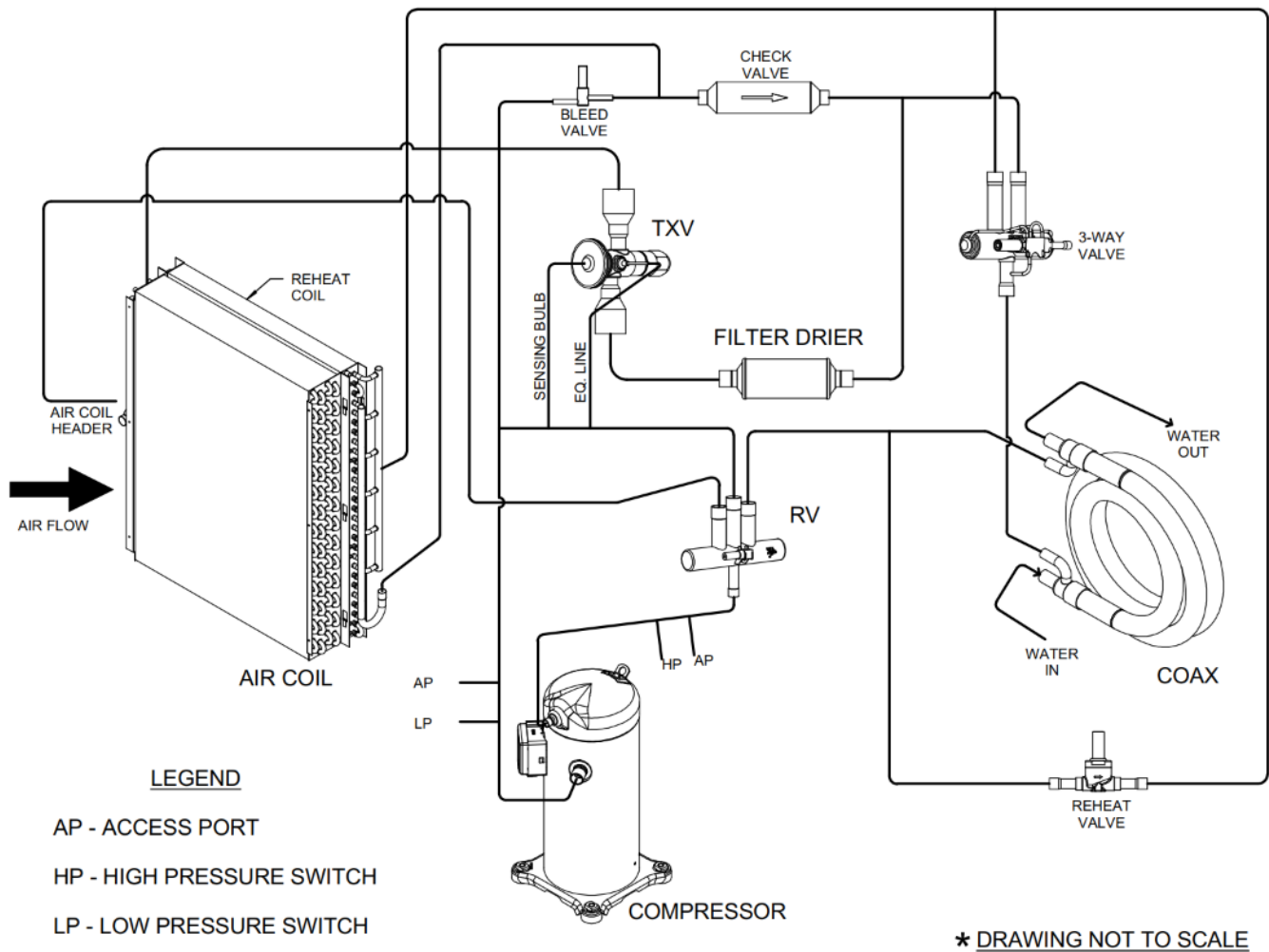

FIGURE 26 - Circuit Diagram HGRH

STARTUP INSTRUCTIONS

PRE-STARTUP CHECKS:

WARNING

Electrically ground the unit. Connect ground wire to ground lug. Failure to do so can result in injury or death.

CAUTION

Wire any field installed device such as a fan switch or thermostat furnished by the factory in strict accordance with the wiring diagram supplied with the unit. Failure to do so could result in damage to components and will void all warranties.

Before start-up, thoroughly check all the components. Optimal operation of equipment requires cleanliness. Often after installation of the equipment, additional construction

activities occur. Protect the equipment from debris during these construction phases.

PRIOR TO THE STARTUP OF THE UNIT:

1. Ensure supply voltage matches nameplate data.
2. Ensure the unit is properly grounded
3. With the power off, check blower wheel set screws for proper tightness and that the blower wheel rotates freely.
4. Ensure unit will be accessible for servicing.
5. Ensure condensate line is properly sized, run, trapped, pitched and tested.
6. Ensure all cabinet openings and wiring connections have been sealed.
7. Ensure clean filters are in place.
8. Ensure all access panels are in place and secured.

STARTUP INSTRUCTIONS CONTINUED

PRIOR TO THE STARTUP OF THE UNIT:

9. Check that the water coil and piping had been leak checked and insulated as required.
10. Ensure that all air has been vented from the water coil.
11. Make sure that all electrical connections are tight and secure.
12. Check the electrical overcurrent protection and wiring for the correct size.
13. Verify that the low voltage wiring between the thermostat and the unit matches the wiring diagram.
14. Verify that the water piping is complete and correct.
15. Check condensate overflow sensor for proper operation and adjust position if required. Ensure that power is connected to the unit and the local disconnect is switched to ON position.
12. Verify water flow rate is correct according to specification. Adjust if necessary. If specification is not available, the nominal flow rate for this unit is 25 GPM.
13. Instruct the owner on the unit and thermostat operation.

STARTUP & PERFORMANCE CHECKLIST INSTRUCTIONS

The warranty may be void unless the **FIGURE 27 – Startup & Performance Checklist** is completed and returned to the warrantor. If the WSV6 unit is not installed properly, the warranty will be void, as the manufacturer cannot be held accountable for problems that stem from improper installation.

UNIT STARTUP:

1. Turn the disconnect switch to ON position.
2. Check for 24 volt from control transformer. Controller module LED should light up. If not, the power supply lines are out of phase. Turn of the main power disconnect to the unit off and change the phase.by switching any two incoming wires.
3. Set the thermostat to the lowest position. Turn the system switch to “COOL” and the fan switch to “AUTO” position. The reversing valve should energize.
4. After 5 minutes (anti-short cycle protect delay), the fan start at low speed and the compressor is running.
5. Make sure that compressor rotation is correct. If not, turn the power off and make the correction. This is 3-phase unit. Switching compressor rotation could be done by switching any two of compressor wires.
6. Turn the thermostat system to “OFF” position. The unit should stop running and the reversing valve de-energizes.
7. Leave the unit off for approximately 5 minutes to allow the system pressures to equalize. Anti-short cycle feature built in the system will keep the compressor off for 5 minutes.
8. Set the thermostat to the highest setting. Turn the system switch to “HEAT” position.
9. Verify that the unit is operating to the heating mode.
10. Set the thermostat to maintain the desired space temperature.
11. Check for vibrations, leaks, etc.

MAINTENANCE & SERVICE

PREVENTIVE MAINTENANCE

To achieve maximum performance and service life of equipment, a formal schedule of regular maintenance should be established and adhered to.

CAUTION

All appropriate personal protection equipment should be worn when servicing or maintaining this unit. Personal injury can result from sharp metal edges, moving parts, and hot or cold surfaces.

FAN

The fan should be inspected and cleaned annually in conjunction with maintenance of the motor and bearings. It is important to keep the fan section and motor clean and free from obstruction to prevent imbalance, vibration, and improper operation.

WARNING

ELECTRIC SHOCK HAZARD

Check motor connections to ensure they are secure and in accordance with the unit wiring diagram. ECM motors have line voltage power applied at all times. **MAKE SURE POWER IS DISCONNECTED BEFORE SERVICING.**

FILTER

The air filter should be cleaned or replaced every 30 days or more frequently if severe operating conditions exist. Always replace the filter with the same type and size as originally furnished.

COIL

Clean all heat transfer surfaces and remove all dirt, dust, and contaminants that potentially impairs air flow using industry accepted practices. Care should be taken not to bend coil fin material.

CONDENSATE DRAIN PAN AND PIPE

Check and clean all dirt and debris from pan. Ensure drain line is free flowing and unobstructed.

MAINTENANCE UPDATES

Check regularly for a current copy of the maintenance program log, which can be found at under “product information”.

CLEANING/FLUSHING

Before the unit is connected to the supply water, the water circulating system must be cleaned and flushed to remove any dirt or debris for the system.

1. Connect the supply and return water lines together in order to bypass the unit. This will prevent dirt or debris from getting into the system during the flushing process.
2. Start the main water circulating pump and allow for water to circulate in the system. Open drains at the lowest point in the system and drain out the water while simultaneously filling the loop with city water. Continue to exchange the loop water with the city water for a minimum of two hours, or until drain water is clear. During this time, check to make sure there are no leaks within the system.
3. Open all drains and vents to drain water system and refill with clean water. Test the system water quality and treat as necessary in order to bring water quality to within requirements for the system. Water PH level should be 7.5 to 8.5. Antifreeze may be added if required.
4. Connect the water-source heat pump supply and return lines, following proper installation procedures outlined in the piping installation section. After the installation has been checked for leaks, bring the water-loop to the desired set point and vent any air within the loop.

UNIT PERFORMANCE

Record performance measurements of volts, amps and water temperature differences (both heating and cooling). A comparison of logged data with start-up and other annual data is useful as an indicator of general equipment condition.

UNIT LOCKOUT

Air or water problem could cause periodic lockouts. The lockout (shutdown) of the units is a normal protective result. Check for dirt in the water system, water flow rates, water temperatures, airflow rates (may be caused by dirty filter) and air temperatures.

LABORATORY TESTING

When the unit has less than 100 operational hours and the coils have not had sufficient time to be “seasoned”, it is necessary to clean the coils with a mild surfactant such as Calgon to remove the oils left by manufacturing processes.

TROUBLESHOOTING

PROBLEM	POSSIBLE CAUSE	CHECKS & CORRECTIONS
ENTIRE UNIT DOES NOT RUN	Power supply off	Apply power; close disconnect.
	Blown Fuse	Replace fuse or reset circuit breaker. Check for correct fuses.
	Voltage supply low	If voltage is below minimum voltage specified on unit dataplate, contact lower power company. (Fault Code – Ou & 17).
	Thermostat	Set the fan to “ON”, the fan should run. Set thermostat to “COOL” and lowest temperature setting, the unit should run in the cooling mode (reversing valve energized). Set unit to “HEAT” and the highest temperature setting, the unit should run in the heating mode. If neither the blower nor compressor run in all three cases, the thermostat could be mis-wired or faulty. To ensure mis-wired or faulty thermostat verify 24 volts is available on the condenser section low voltage terminal strip between “R” and “C”, “Y” and “C”, and “O” and “C”. If blower does not operate, verify 24 volts between terminals “G” and “C” in the air handler. Replace the thermostat if defective.
BLOWER OPERATES BUT COMPRESSOR DOES NOT RUN	Thermostat	Check setting, calibration and wiring.
	Wiring	Check for loose or broken wires at compressor, capacitor or contractor.
	Safety Controls	Check control board fault LED for fault code.
	Compressor overload open	If the compressor is cool and the overload will not reset, replace the compressor.
	Compressor motor grounded	Internal wiring grounded to the compressor shell. Replace compressor. If compressor burnout, install new filter dryer.
	Compressor windings open	After compressor has cooled, check continually of compressor windings. If the windings are open, replace the compressor.
UNIT OFF ON HIGH PRESSURE CONTROL FAULT CODE 12	Discharge pressure too high	In “COOLING” mode: Lack of or inadequate water flow. Entering water temperature too warm. Scaled or restricted water to refrigerant heat exchanger. In “HEATING” mode: Lack of or inadequate water flow. Entering water temperature too cold. Scaled or restricted water to refrigerant heat exchanger.
	Refrigerant charge	The unit is overcharged with refrigerant. Reclaim refrigerant, evacuate and recharge with factory recommended charge.
	High pressure switch	Check for defective or improperly calibrated high pressure switch.
UNIT OFF ON LOW PRESSURE CONTROL FAULT CODE 13	Suction Pressure too low	In “COOLING” mode: Lack of or inadequate airflow. Entering air temperature too cold. Blower inoperative, clogged filter or restriction in ductwork. In “HEATING” mode: Lack of or inadequate water flow. Entering water temperature too cold. Scaled or restricted water to refrigerant heat exchanger.
	Refrigerant charge	The unit is low on refrigerant. Check for refrigerant leak, repair, evacuate and recharge with factor recommended charge.
	Low pressure switch	Check for defective or improperly calibrated low pressure switch.

Table 28 – Troubleshooting Table

TROUBLESHOOTING CONTINUED

PROBLEM	POSSIBLE CAUSE	CHECKS & CORRECTIONS
UNIT SHORT CYCLES	Unit oversized	Recalculate heating and cooling loads.
	Thermostat	Thermostat installed near a supply air register, relocate thermostat. Check heat anticipator.
	Wiring and controls	Loose connections in the wiring or a defective compressor contactor.
INSUFFICIENT COOLING OR HEATING	Unit undersized	Recalculate heating and cooling loads. If not excessive, possibly adding insulation will rectify the situation.
	Loss of conditioned air by leaks	Check for leaks in ductwork or introduction of ambient air through doors or windows.
	Airflow	Lack of adequate airflow or improper distribution of air. Replace dirty air filter.
	Refrigerant charge	Low on refrigerant charge causing inefficient operation.
	Compressor	Check for defective compressor. If discharge is too low and suction pressure is too high, compressor is not pumping properly. Replace compressor.
	Reversing valve	Defective reversing valve creating bypass of refrigerant from discharge to suction side of compressor. Discharge is too low and suction is too high. Replace reversing valve.
	Operating pressures	Compare unit operating pressures to the pressure / temperature chart for the unit.
	Refrigerant metering device	Check for possible restriction or defect. Replace is necessary.
Moisture, non-condensables	The refrigerant system may be contaminated with moisture or non-condensables. Reclaim refrigerant, evacuate and recharge with factory recommended charge. Replace filter dryer.	

Table 29 – Troubleshooting Table Continued

SUPPORT/REFERENCE MATERIAL

REFERENCE CALCULATIONS

HEATING

$$LDB = EDB + \frac{QH}{GPM \times 500}$$

$$LWT = EAT + \frac{QA}{cfm \times 1.08}$$

COOLING

$$LDB = EDB - \frac{SC}{cfm \times 1.08}$$

$$LWT = EWT + \frac{QR}{GPM \times 500}$$

$$LC = QC - SC$$

$$SHR = \frac{SC}{QC}$$

ABBREVIATIONS & DEFINITIONS

LDB = Leaving air temperature dry bulb °F

EDB = Entering air temperature dry bulb °F

GPM = Water flow rate gallons per minute

CFM = Airflow rate cubic feet per minute

QH = Heating capacity Btuh

QA = Heat of absorption Btuh

SC = Sensible cooling capacity Btuh

QR = Heat of rejection Btuh

LC = Latent cooling capacity Btuh

SHR = Sensible heat ratio

COMMON CONVERSIONS

Air Flow	l/s = CFM x .47
Water Flow	l/s = GPM x .06
Static Pressure	Pa = IWC x 249
Water Pressure Drop	FOH = PSI x 2.3
Temperature	°C = (°F - 32) x 5/9
Power	kW = Btuh / 3412
Weight	oz = lb x 16
Weight	kg = lb / 2.2
EER	COP x 3.413
COP	EER / 3.413

STARTUP & PERFORMANCE CHECKLIST



CUSTOMER _____
ADDRESS _____

MODEL # _____

STARTUP DATE _____ **JOB #** _____
SERVICE COMPANY _____
TECHNICIAN _____
SERIAL # _____ **PHONE #** _____

VISUAL INSPECTION

- Air Filter Condition
- Evaporator Coil Condition
- Blower Wheel
- Signs of sweating on plenum/cabinet
- Signs of condensate outside pan
- Condensate Drain Clear

ACCESSORIES INSTALLED

- Hart Start Kit
 Typebrand: _____
- Compressor Cover
- Vacated Premises Switch

CONTROL MODULE SWITCH POSITION

- | | |
|---|---|
| <u>Dip Switch #1</u> | <u>Dip Switch #2</u> |
| Off On | Off On |
| <input type="checkbox"/> <input type="checkbox"/> Switch #1 | <input type="checkbox"/> <input type="checkbox"/> Switch #1 |
| <input type="checkbox"/> <input type="checkbox"/> Switch #2 | <input type="checkbox"/> <input type="checkbox"/> Switch #2 |
| <input type="checkbox"/> <input type="checkbox"/> Switch #3 | <input type="checkbox"/> <input type="checkbox"/> Switch #3 |
| <input type="checkbox"/> <input type="checkbox"/> Switch #4 | <input type="checkbox"/> <input type="checkbox"/> Switch #4 |
| <input type="checkbox"/> <input type="checkbox"/> Switch #5 | |
| <input type="checkbox"/> <input type="checkbox"/> Switch #6 | |
| <input type="checkbox"/> <input type="checkbox"/> Switch #7 | |

Unit in Lock Out? _____

Fault Code Displayed in Test Mode? _____

PROBLEM SUMMARY:

CORRECTIVE ACTIONS TAKEN:

UNIT OPERATION

Primary Voltage to the Heat Pump: _____
 Transformer Secondary Voltage: _____
 Unit Grounded (Y/N)? _____
 Low Side PSIG: _____ Vapor Line Temp: _____ Saturated Temp: _____
 [Vapor Line Temp – Saturated Temp = **Superheat**]*
 High Side PSIG: _____ Saturated Temp: _____ Liquid Line Temp: _____
 [Saturated Temp – Liquid Line Temp = **Sub Cooling**]*

DUCT SYSTEM STATIC PRESSURE

Supply Static Pressure: _____
 Return Static Pressure: _____
 Total External Static Pressure: _____

EVAPORATOR COIL TEMPERATURES:

Evaporator Coil EAT Dry Bulb: _____
 Evaporator Coil LAT Dry Bulb: _____
 Delta: _____
 Evaporator Coil EAT Dry Bulb: _____
 Evaporator Coil EAT Dry Bulb: _____
 Delta: _____

HEAT EXCHANGER TEMPERATURE

Cond Entering Water Temp: _____
 Cond Leaving Water Temp: _____
 Cond Temp Rise: _____

The warranty may be void unless the Startup & Performance Checklist is completed and returned to the warrantor. If the HVAC unit is not installed properly, the warranty will be void, as the manufacturer cannot be held accountable for problems that stem from improper installation.

FIGURE 27 – Startup & Performance Checklist

NOTES



P.O. Box 270969 Dallas, TX 75227
www.firstco.com or www.ae-air.com

The manufacturer works to continually improve its products. It reserves the right to change design and specifications without notice.

©2022 First Co., Applied Environmental Air