



FIRST CO.  
P.O. BOX 270969 - DALLAS, TEXAS 75227  
PH. (214) 388-5751 | FAX (214) 388-2255  
WWW.FIRSTCO.COM

# HYB-PHYB Series

*LO BOY HORIZONTAL HYDRONIC FAN COILS*

500-2000 CFM

## NEW OPTIONS AVAILABLE

**ECM MOTORS OR PSC MOTORS WITH  
AUTOSPEED 24 CONTROLS**

- ✓ Quiet Operation
- ✓ Low Silhouette (16-1/2")
- ✓ Compact Design
- ✓ Durable Construction
- ✓ 4 speed direct drive motors
- ✓ Available in 3, 4, and 5 ton series

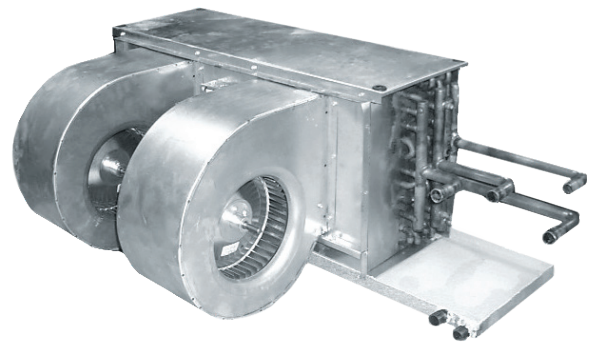

**HYB Series**  
Hydronic

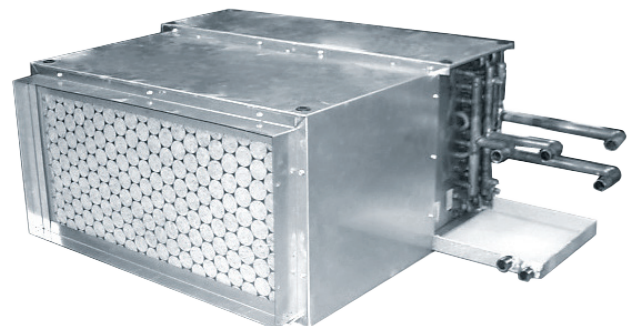

**PHYB Series**  
Hydronic w/ Plenum

# Table of Contents

<b>SECTIONS</b>	<b>PAGE</b>
HYB Blower Data	2
PHYB Blower Data	3
(P)HYB ECM Blower Data	4-6
Cooling Data	7
Heating Data	8
Capacity Factors	8
HYB Dimensions / Submittal Data	9
PHYB Dimensions / Submittal Data	10
Valves & Individual Components	11
Optional 24V Control Package	12
Guide Specifications	13

# HYB Series

## PSC MOTOR

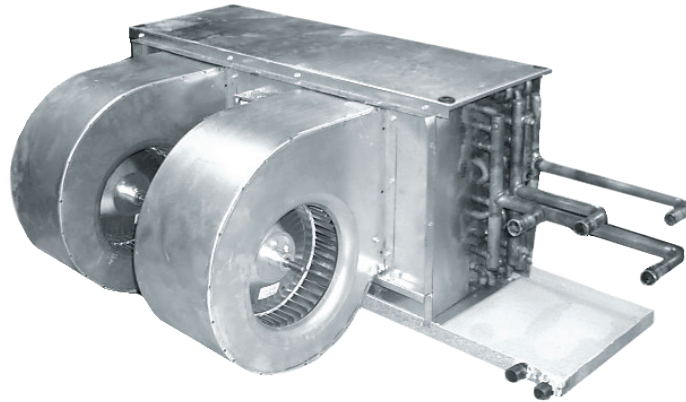

### FEATURES

1. Manual air vents
2. 4-speed direct drive motors
3. 1/2" copper tubing
4. Primary and secondary condensate drains on one end
5. 120V/1/60Hz. motors (2)
6. 3-row and 6-row models available
7. Rubber isolation grommets
8. Insulated and coated drain pan



HYB BLOWER DATA (4-row coil)											
UNIT MODEL	HP	AMPS*	MIN. CKT. AMPACITY	MAX. CKT. PROTECTION	CFM vs. EXTERNAL STATIC PRESSURE						
					BLOWER SPEED	0.10	0.20	0.30	0.40	0.50	0.60
12HYB4	1/5	5.2	7	15	HIGH	1595	1510	1410	1310	1180	1010
					MED. HI	1310	1250	1190	1100	1000	850
					MED. LOW	1010	980	940	860	760	640
					LOW	690	640	580	510	440	340
16HYB4	1/5	5.2	7	15	HIGH	1820	1740	1660	1560	1440	1300
					MED. HI	1420	1380	1320	1260	1160	1040
					MED. LOW	1060	1020	960	900	800	700
					LOW	720	660	580	500	400	260
20HYB4	1/4	8.8	12	15	HIGH	2510	2230	2260	2120	1960	1760
					MED. HI	2040	2040	1960	1850	1720	1540
					MED. LOW	1580	1580	1540	1480	1380	1180
					LOW	1200	1190	1160	1100	1010	880

120V-1PH-60HZ

\* Amps is total for (2) motors

3-row coil - add 0.05 to ESP shown

6-row coil - deduct 0.10 from ESP shown

In keeping with its policy of continuous progress and product improvement, First Co. reserves the right to make changes without notice. Maintenance for all First Co. products is available under "Product Maintenance" at [www.firstco.com](http://www.firstco.com).

# PHYB Series

## PSC MOTOR

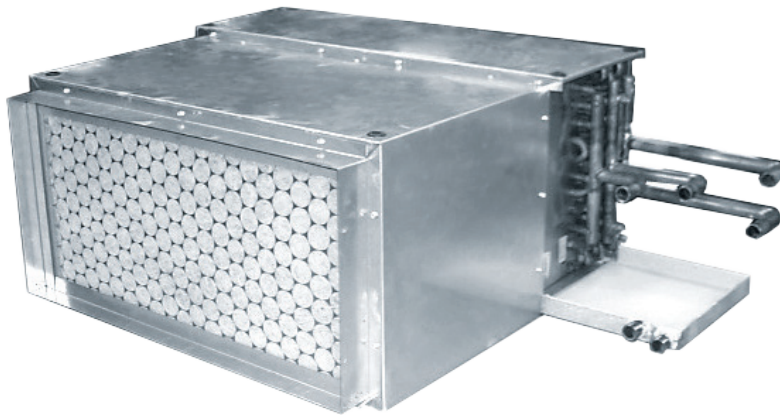

### FEATURES

1. Manual air vents
2. 4-speed direct drive motors
3. 1/2" copper tubing
4. Primary and secondary condensate drains on one end
5. Return air plenum - field convertible from end return to bottom return
6. Throw away filter
7. 120V/1/60Hz. motors (2)
8. 3-row and 6-row models available
9. Rubber isolation grommets
10. Insulated and coated drain pan



PHYB BLOWER DATA (4-row coil)											
UNIT MODEL	HP	AMPS*	MIN. CKT. AMPACITY	MAX. CKT. PROTECTION	CFM vs. EXTERNAL STATIC PRESSURE						
					BLOWER SPEED	0.10	0.20	0.30	0.40	0.50	0.60
12PHYB4	1/5	5.2	7	15	HIGH	1400	1320	1220	1110	980	820
					MED. HI	1220	1150	1080	980	860	710
					MED. LOW	980	930	860	790	680	560
					LOW	600	600	550	490	420	340
16PHYB4	1/5	5.2	7	15	HIGH	1700	1620	1520	1420	1290	1130
					MED. HI	1370	1320	1260	1180	1060	910
					MED. LOW	1030	980	920	850	760	640
					LOW	690	630	560	480	380	230
20PHYB4	1/4	8.8	12	15	HIGH	2160	2160	2020	1880	1720	1520
					MED. HI	2000	1900	1800	1680	1520	1310
					MED. LOW	1570	1520	1470	1380	1230	1000
					LOW	1170	1140	1100	1040	940	800

120V-1PH-60HZ

\* Amps is total for (2) motors

3-row coil - add 0.05 to ESP shown

6-row coil - deduct 0.10 from ESP shown

## 12 (P)HYBX ECM BLOWER DATA

Coil	Voltage	Motor Speed	FLA	Max. Breaker	0	0.1	0.2	0.3	0.4	0.5
3 Row	120V	High	9.6	15	1400	1330	1310	1240	1190	1100
		Med.			1110	1040	990	930	860	800
		Low			890	780	690	600	530	460
	230V	High	5.6	15	1370	1310	1270	1230	1190	1140
		Med.			1090	1040	990	930	860	800
		Low			840	770	700	620	530	460
	265V	High	5.2	15	1400	1330	1270	1230	1180	1120
		Med.			1140	1070	1000	930	880	820
		Low			900	790	710	640	550	460
4 Row	120V	High	9.6	15	1320	1290	1250	1190	1150	1090
		Med.			1070	1010	940	890	840	760
		Low			830	750	680	600	510	470
	230V	High	5.6	15	1350	1300	1250	1210	1150	1110
		Med.			1080	1020	950	890	840	770
		Low			830	760	670	600	510	450
	265V	High	5.2	15	1330	1280	1240	1190	1140	1090
		Med.			1090	1030	960	890	840	780
		Low			830	760	690	620	520	440
5 Row	120V	High	9.6	15	1330	1270	1240	1190	1140	1050
		Med.			1040	970	930	860	830	740
		Low			790	720	650	570	510	430
	230V	High	5.6	15	1310	1260	1220	1160	1120	1080
		Med.			1030	980	930	870	790	740
		Low			790	720	640	570	500	440
	265V	High	5.2	15	1300	1260	1220	1170	1110	1030
		Med.			1070	1000	940	890	830	750
		Low			810	730	680	580	500	440
6 Row	120V	High	9.6	15	1310	1260	1210	1170	1110	1030
		Med.			1020	980	920	850	800	720
		Low			780	720	630	560	490	420
	230V	High	5.6	15	1300	1250	1210	1160	1120	1070
		Med.			1030	970	910	860	800	740
		Low			790	720	650	570	500	430
	265V	High	5.2	15	1300	1260	1210	1160	1110	1030
		Med.			1060	1000	930	880	820	750
		Low			800	740	670	580	500	430

Amps based on 2 -1/3HP motors per unit

# 16 (P)HYBX ECM BLOWER DATA

Coil	Voltage	Motor Speed	FLA	Max. Breaker	0	0.1	0.2	0.3	0.4	0.5
3 Row	120V	High	9.6	15	1760	1720	1650	1610	1540	1480
		Med. Low			1440	1410	1340	1280	1230	1150
		Low			1210	1160	1060	1000	910	860
	230V	High	5.6	15	1780	1730	1670	1610	1550	1500
		Med. Low			1500	1440	1380	1310	1250	1190
		Low			1260	1180	1100	1020	940	860
	265V	High	5.2	15	1770	1700	1650	1600	1540	1470
		Med. Low			1510	1430	1370	1300	1230	1170
		Low			1260	1180	1090	1010	930	860
4 Row	120V	High	9.6	15	1760	1700	1650	1600	1550	1490
		Med. Low			1470	1420	1350	1290	1230	1170
		Low			1200	1130	1070	1010	930	870
	230V	High	5.6	15	1750	1710	1640	1600	1540	1490
		Med. Low			1490	1430	1370	1300	1250	1190
		Low			1240	1170	1090	1010	940	860
	265V	High	5.2	15	1750	1700	1650	1590	1550	1480
		Med. Low			1480	1420	1370	1300	1230	1180
		Low			1250	1160	1090	1010	950	870
5 Row	120V	High	9.6	15	1700	1640	1600	1550	1500	1450
		Med. Low			1420	1370	1300	1240	1190	1140
		Low			1170	1100	1030	980	890	820
	230V	High	5.6	15	1710	1660	1610	1570	1510	1460
		Med. Low			1450	1390	1330	1270	1220	1170
		Low			1210	1120	1060	990	920	840
	265V	High	5.2	15	1700	1640	1590	1540	1490	1440
		Med. Low			1430	1370	1320	1260	1200	1140
		Low			1210	1120	1040	980	910	820
6 Row	120V	High	9.6	15	1680	1630	1570	1540	1470	1420
		Med. Low			1390	1350	1290	1250	1180	1130
		Low			1150	1080	1020	960	890	810
	230V	High	5.6	15	1680	1630	1580	1530	1490	1430
		Med. Low			1420	1360	1320	1260	1200	1130
		Low			1180	1110	1040	970	910	830
	265V	High	5.2	15	1670	1620	1560	1520	1480	1420
		Med. Low			1420	1360	1300	1240	1190	1140
		Low			1180	1100	1030	980	910	830

Amps based on 2-1/3HP motors per unit

## 20 (P)HYBX ECM BLOWER DATA

Coil	Voltage	Motor Speed	FLA	Max. Breaker	0	0.1	0.2	0.3	0.4	0.5
3 Row	120V	High	9.6	15	2200	2140	2080	2020	1970	1900
		Med.			1830	1760	1700	1640	1560	1480
		Low			1600	1390	1320	1260	1150	1070
	230V	High	5.6	15	2130	2070	2030	1950	1900	1820
		Med.			1770	1690	1630	1540	1470	1390
		Low			1460	1310	1220	1140	1040	950
	265V	High	5.2	15	2160	2100	2040	1970	1910	1850
		Med.			1790	1710	1640	1560	1480	1400
		Low			1570	1360	1260	1160	1050	970
4 Row	120V	High	9.6	15	2100	2040	1990	1930	1880	1810
		Med.			1750	1670	1620	1550	1480	1420
		Low			1430	1340	1250	1190	1110	1000
	230V	High	5.6	15	2180	2100	2040	1990	1930	1860
		Med.			1790	1710	1640	1570	1490	1420
		Low			1420	1330	1240	1150	1060	970
	265V	High	5.2	15	2170	2110	2040	1980	1920	1850
		Med.			1790	1710	1650	1570	1500	1420
		Low			1480	1350	1250	1170	1060	970
5 Row	120V	High	9.6	15	2140	2070	2010	1960	1900	1840
		Med.			1770	1690	1640	1570	1500	1450
		Low			1460	1370	1270	1210	1120	1030
	230V	High	5.6	15	2100	2040	1970	1910	1860	1800
		Med.			1730	1650	1580	1510	1440	1370
		Low			1370	1280	1190	1110	1020	930
	265V	High	5.2	15	2110	2050	2000	1930	1870	1810
		Med.			1760	1670	1610	1530	1460	1390
		Low			1440	1310	1230	1140	1040	970
6 Row	120V	High	9.6	15	2070	2000	1950	1890	1830	1730
		Med.			1710	1650	1590	1520	1460	1390
		Low			1400	1310	1250	1170	1100	990
	230V	High	5.6	15	2050	1990	1930	1870	1810	1750
		Med.			1680	1600	1530	1490	1400	1340
		Low			1330	1250	1170	1090	990	900
	265V	High	5.2	15	2010	1950	1890	1840	1790	1700
		Med.			1650	1580	1510	1450	1390	1320
		Low			1330	1240	1160	1080	980	910

Amps based on 2 -1/3HP motors per unit

# COOLING DATA

## (P)HYB-3

(3-Row Coil) All capacities are based on nominal CFM.

COOLING CAPACITY (1000 BTUH)																
MODEL (CFM)	45° ENTERING WATER								42° ENTERING WATER							
	GPM	P.D. (FT. WTR.)	80° DB 67° WB			75° DB 63° WB			GPM	P.D. (FT. WTR.)	80° DB 67° WB			75° DB 63° WB		
			TH	SH	TR	TH	SH	TR			TH	SH	TR	TH	SH	TR
12HYB-3 (1200)	5	2.6	30.1	24.2	12.0	23.0	21.4	9.2	6	3.6	35.5	26.2	11.8	27.1	23.0	9.0
	7	4.7	34.5	25.8	10.0	26.4	22.7	7.5	8	6.0	39.3	27.6	9.8	30.0	24.1	7.5
	9	7.4	37.3	26.9	8.3	28.5	23.5	6.3	10	9.0	41.7	28.5	8.3	31.8	24.8	6.4
16HYB-3 (1600)	6	1.8	37.6	31.4	12.5	32.5	32.5	10.8	7	2.4	44.1	33.8	12.6	33.7	29.8	9.6
	9	3.7	44.9	34.1	10.0	34.3	30.0	7.6	10	4.5	50.9	36.3	10.2	38.9	31.8	7.8
	12	6.3	49.4	35.8	8.2	37.8	31.3	6.3	13	7.3	55.1	37.9	8.5	42.1	33.0	6.5
20HYB-3 (2000)	8	2.1	54.8	39.5	11.9	35.0	35.0	8.5	10	3.2	57.5	43.1	11.5	43.9	37.9	8.8
	11	3.8	57.7	42.1	10.0	41.9	37.1	7.6	13	5.2	63.5	45.3	9.8	48.5	39.6	7.5
	14	5.9	59.7	43.9	8.5	45.6	38.5	6.5	16	7.6	67.7	46.9	8.5	51.7	40.9	6.5

## (P)HYB-4

(4-Row Coil) All capacities are based on nominal CFM.

COOLING CAPACITY (1000 BTUH)																
MODEL (CFM)	45° ENTERING WATER								42° ENTERING WATER							
	GPM	P.D. (FT. WTR.)	80° DB 67° WB			75° DB 63° WB			GPM	P.D. (FT. WTR.)	80° DB 67° WB			75° DB 63° WB		
			TH	SH	TR	TH	SH	TR			TH	SH	TR	TH	SH	TR
12HYB-4 (1200)	6.5	5.2	39.3	29.5	12.1	30.0	25.8	9.2	7.5	6.7	45.0	31.7	12.0	34.4	27.6	9.2
	8.5	8.5	42.9	30.8	10.1	32.8	26.9	7.7	9.5	10.4	48.2	32.9	10.1	36.8	28.5	7.7
	11.5	14.7	45.9	32.0	8.0	35.1	27.8	6.1	13.0	18.4	51.0	34.0	8.0	39.0	29.4	6.0
16HYB-4 (1600)	8.5	4.2	51.3	38.9	12.1	39.2	34.1	9.2	10.0	5.6	59.4	41.9	11.9	45.4	36.6	9.1
	11.5	7.3	57.0	41.1	9.9	43.5	35.9	7.6	13.0	9.1	64.3	43.9	9.9	49.1	38.1	7.6
	15.0	11.8	61.0	42.6	8.1	46.6	37.1	6.2	17.0	14.9	68.0	45.3	8.0	51.9	39.2	6.1
20HYB-4 (2000)	10.5	4.6	62.8	48.1	12.0	48.0	42.3	9.1	12.0	5.9	72.1	51.7	12.0	55.1	45.1	9.2
	14.0	7.7	69.8	50.7	10.0	53.3	44.4	7.7	16.0	9.8	79.1	54.3	9.9	60.4	47.2	7.6
	19.0	13.4	75.7	53.0	8.0	57.8	46.1	6.1	21.0	16.0	84.1	56.3	8.0	64.3	48.7	6.1

## (P)HYB-5

(5-Row Coil) All capacities are based on nominal CFM.

COOLING CAPACITY (1000 BTUH)																
MODEL (CFM)	45° ENTERING WATER								42° ENTERING WATER							
	GPM	P.D. (FT. WTR.)	80° DB 67° WB			75° DB 63° WB			GPM	P.D. (FT. WTR.)	80° DB 67° WB			75° DB 63° WB		
			TH	SH	TR	TH	SH	TR			TH	SH	TR	TH	SH	TR
12HYB-6 (1200)	8.0	10.2	48.0	33.0	12.0	36.7	28.6	9.2	9.0	12.6	54.1	35.4	12.0	41.3	30.5	9.2
	10.0	15.3	50.9	34.1	10.2	38.9	29.5	7.8	11.5	19.1	57.0	36.6	9.9	43.6	31.4	7.6
	13.0	24.6	53.3	35.1	8.2	40.7	30.3	6.3	14.5	30.1	59.0	37.4	8.1	45.1	32.1	6.2
16HYB-6 (1600)	10.5	7.3	63.0	43.6	12.0	48.1	37.9	9.2	12.0	9.2	71.6	47.0	11.9	54.7	40.5	9.1
	13.5	11.4	67.7	45.0	10.0	51.7	39.3	7.7	15.0	13.8	75.6	48.6	10.1	57.7	41.8	7.7
	18.0	19.2	71.6	47.0	8.0	54.7	40.5	6.1	20.0	23.2	79.2	50.1	7.9	60.5	42.9	6.0
20HYB-6 (2000)	12.0	9.1	77.5	54.0	11.9	59.2	46.9	9.1	14.5	11.1	87.5	58.0	12.1	66.8	50.0	9.2
	17.0	14.9	83.9	56.5	9.9	64.1	48.9	7.5	19.0	18.2	93.9	60.5	9.9	71.7	52.0	7.5
	22.0	23.8	88.6	58.4	8.1	67.6	50.4	6.1	24.5	29.0	98.1	62.3	8.0	74.9	53.4	6.1

**LEGEND:** TH - Total Heat      SH - Sensible Heat      TR - Water Temperature Rise



# HEATING DATA

## (P)HYB-3

3-Row Coil / 2-Pipe

HEATING CAPACITY (1000 BTUH)						
MODEL (CFM)	GPM	P.D. (FT. WTR.)	ENTERING WATER TEMP.			
			180°F	160°F	140°F	120°F
12HYB-3 (1200)	7	4.7	96	78	61	43
	10	9.0	100	82	63	45
	13	14.4	101	83	64	46
16HYB-3 (1600)	10	4.5	129	105	82	59
	13	7.3	133	109	85	60
	15	9.5	135	110	86	61
20HYB-3 (2000)	12	4.5	159	130	101	72
	16	7.6	165	135	105	75
	20	11.5	168	137	107	76

## (P)HYB-1

1-Row Coil / 4-Pipe

HEATING CAPACITY (1000 BTUH)						
MODEL (CFM)	GPM	P.D. (FT. WTR.)	ENTERING WATER TEMP.			
			180°F	160°F	140°F	120°F
12HYB (1200)	1.0	1.8	30	24	19	14
	2.5	8.7	39	32	25	18
	4.0	19.8	42	34	27	19
16HYB (1600)	1.0	2.5	38	31	24	17
	2.5	11.8	49	40	31	22
	4.0	26.1	54	44	34	24
20HYB (2000)	1.0	3.1	45	37	29	20
	2.5	14.6	58	47	37	26
	4.0	32.4	65	53	41	30

## (P)HYB-4

4-Row Coil / 2-Pipe

HEATING CAPACITY (1000 BTUH)						
MODEL (CFM)	GPM	P.D. (FT. WTR.)	ENTERING WATER TEMP.			
			180°F	160°F	140°F	120°F
12HYB-4 (1200)	6	4.5	107	88	68	49
	8	7.6	111	91	71	50
	10	15.9	115	94	73	52
16HYB-4 (1600)	8	3.7	142	116	90	64
	12	7.9	150	123	95	68
	15	11.8	153	125	97	70
20HYB-4 (2000)	10	4.2	176	144	112	80
	14	7.7	185	151	118	84
	18	12.2	190	155	121	86

## (P)HYB-2

2-Row Coil / 4-Pipe

HEATING CAPACITY (1000 BTUH)						
MODEL (CFM)	GPM	P.D. (FT. WTR.)	ENTERING WATER TEMP.			
			180°F	160°F	140°F	120°F
12HYB (1200)	4	1.5	69	56	44	31
	8	5.2	77	63	49	35
	12	11.0	80	65	51	36
16HYB (1600)	8	2.7	99	81	63	45
	12	5.5	105	86	67	48
	16	9.3	108	88	69	49
20HYB (2000)	12	4.1	126	103	80	57
	16	6.7	131	107	83	60
	20	10.0	134	110	85	61

## (P)HYB-6

6-Row Coil / 2-Pipe

HEATING CAPACITY (1000 BTUH)						
MODEL (CFM)	GPM	P.D. (FT. WTR.)	ENTERING WATER TEMP.			
			180°F	160°F	140°F	120°F
12HYB-6 (1200)	8	10.2	124	101	79	56
	10	15.3	127	104	81	58
	14	28.2	130	106	83	59
16HYB-6 (1600)	10	6.7	165	135	105	75
	14	12.2	171	140	109	78
	18	19.2	174	142	111	79
20HYB-6 (2000)	12	7.9	203	166	129	92
	17	14.9	212	173	135	96
	22	23.8	216	177	137	98

### CFM FACTORS

% NOMINAL CFM	TOTAL COOLING	SENSIBLE COOLING	HEATING
50	0.68	0.60	0.58
75	0.85	0.81	0.81
100	1.00	1.00	1.00
125	1.12	1.17	1.16
150	1.21	1.33	1.18

#### NOTES:

1. Ratings at 70 degree entering air temp.
2. Contact factory for capacities at other conditions

# HYB DIMENSIONS / SUBMITTAL DATA

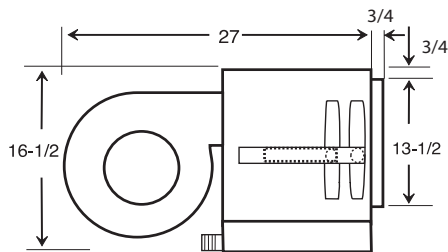
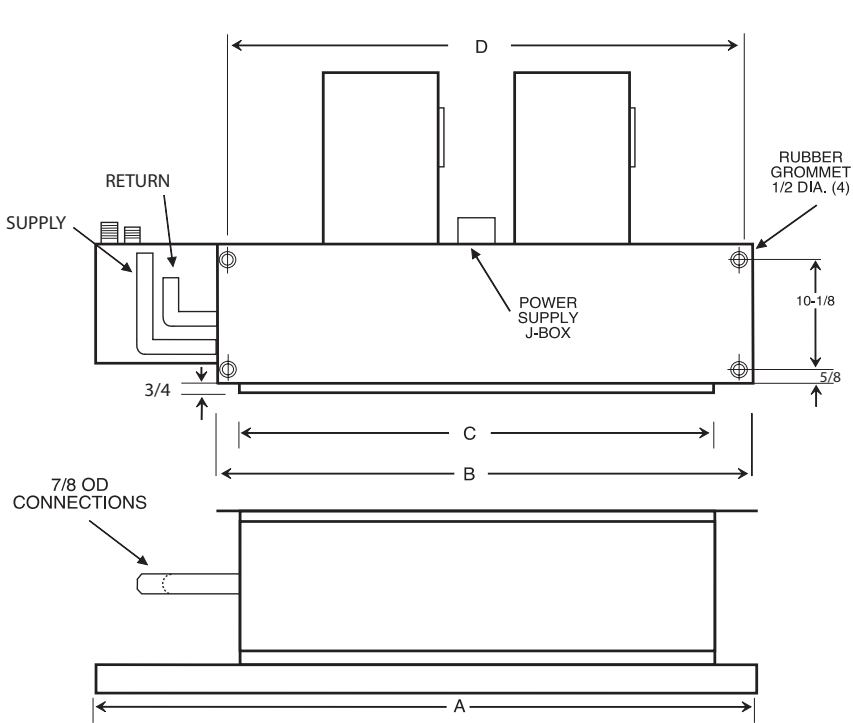

3/4 MPT DRAIN  
PRIMARY AND  
SECONDARY

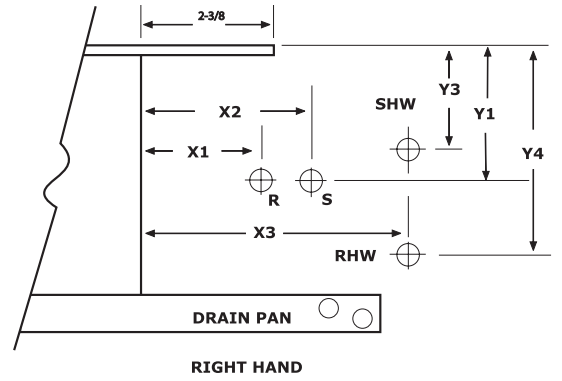

RIGHT HAND

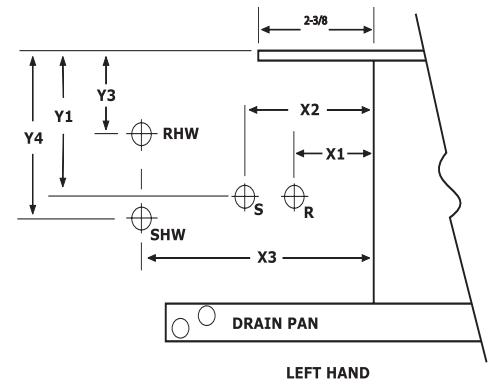

LEFT HAND

**NOTES:**

- 1) ALL DIMENSIONS IN INCHES.
- 2) COIL CONNECTION TOLERANCE  $\pm 1/4"$ .
- 3) RIGHT HAND UNIT SHOWN, LEFT HAND MIRROR IMAGE.

HYB PIPE LOCATIONS						
RIGHT HAND	X1	Y1	X2	X3	Y3	Y4
<b>3 ROW</b>	5-1/4	7-9/16	8-1/4	---	---	---
<b>4 ROW</b>	5-1/4	7-9/16	8-1/4	---	---	---
<b>6 ROW</b>	5-1/4	7-9/16	8-1/4	---	---	---
<b>3/1 ROW</b>	5-1/4	7-9/16	8-1/4	13-1/4	5-7/16	9-11/16
<b>3/2 ROW</b>	5-1/4	7-9/16	8-1/4	13-1/4	6-1/16	9-1/16
<b>4/1 ROW</b>	5-1/4	7-9/16	8-1/4	13-1/4	6-1/16	9-1/16
<b>4/2 ROW</b>	5-1/4	7-9/16	8-1/4	13-1/4	6-1/16	9-1/16

HYB PIPE LOCATIONS						
LEFT HAND	X1	Y1	X2	X3	Y3	Y4
<b>3 ROW</b>	5-1/4	7-9/16	8-1/4	---	---	---
<b>4 ROW</b>	5-1/4	7-9/16	8-1/4	---	---	---
<b>6 ROW</b>	5-1/4	7-9/16	8-1/4	---	---	---
<b>3/1 ROW</b>	5-1/4	7-9/16	8-1/4	13-1/4	5-7/16	8-7/16
<b>3/2 ROW</b>	5-1/4	7-9/16	8-1/4	13-1/4	6-1/16	9-1/16
<b>4/1 ROW</b>	5-1/4	7-9/16	8-1/4	13-1/4	6-1/16	9-1/16
<b>4/2 ROW</b>	5-1/4	7-9/16	8-1/4	13-1/4	6-1/16	9-1/16

**SHIPPING WEIGHTS**

MODEL	WEIGHT (lbs.)
<b>12HYB</b>	105
<b>16HYB</b>	150
<b>20HYB</b>	160

**GENERAL DIMENSIONS**

MODEL	A	B	C	D
<b>12HYB</b>	41	32-1/2	28	31-1/4
<b>16HYB</b>	51	42-1/2	38	41-1/4
<b>20HYB</b>	60	51-1/2	47	50-1/4

## PRODUCT DRAWING

FAN COIL UNITS  
MODEL **HYB**  
NOT FOR CONSTRUCTION

Project Name:  
Location:  
Engineer:  
Contractor:  
For: REFERENCE

Sold To:  
Cust Purch Order #:

Quote Date:  
Rev. Date:  
Form No.:  
Dwg. Lev.:  
Dwg. Scale: NTS



# PHYB DIMENSIONS / SUBMITTAL DATA

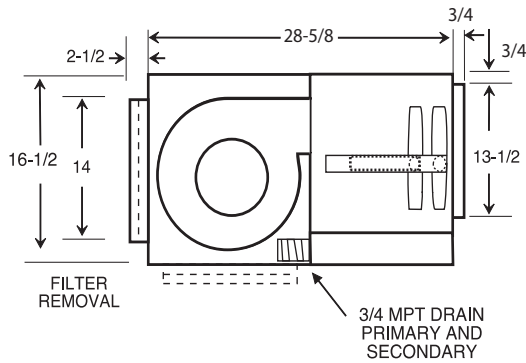
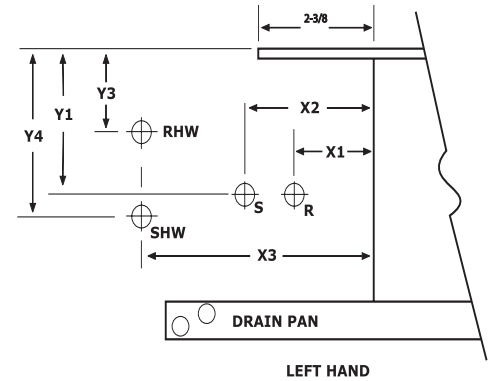
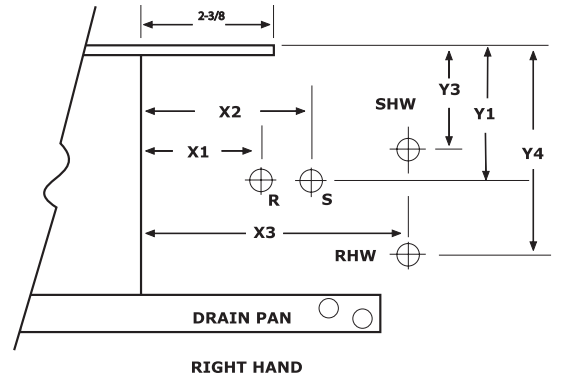
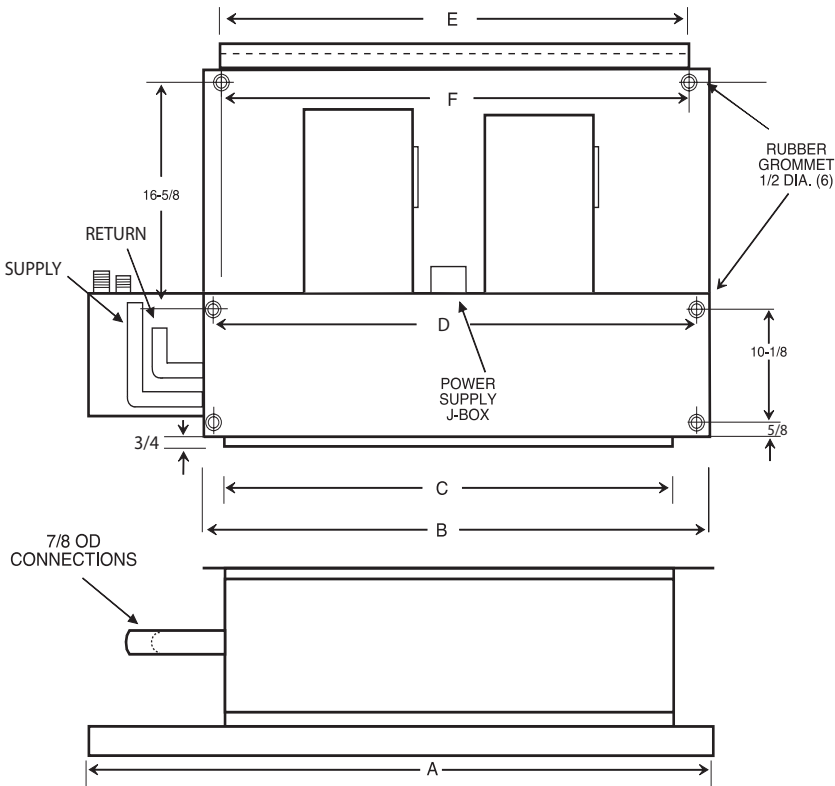

**NOTES:**

- 1) ALL DIMENSIONS IN INCHES.
- 2) COIL CONNECTION TOLERANCE ± 1/4".
- 3) RIGHT HAND UNIT SHOWN, LEFT HAND MIRROR IMAGE.

PHYB PIPE LOCATIONS						
RIGHT HAND	X1	Y1	X2	X3	Y3	Y4
3 ROW	5-1/4	7-9/16	8-1/4	---	---	---
4 ROW	5-1/4	7-9/16	8-1/4	---	---	---
6 ROW	5-1/4	7-9/16	8-1/4	---	---	---
3/1 ROW	5-1/4	7-9/16	8-1/4	13-1/4	5-7/16	9-11/16
3/2 ROW	5-1/4	7-9/16	8-1/4	13-1/4	6-1/16	9-1/16
4/1 ROW	5-1/4	7-9/16	8-1/4	13-1/4	6-1/16	9-1/16
4/2 ROW	5-1/4	7-9/16	8-1/4	13-1/4	6-1/16	9-1/16

SHIPPING WEIGHTS	
MODEL	WEIGHT (lbs.)
12PHYB	125
16PHYB	170
20PHYB	180

GENERAL DIMENSIONS							
MODEL	A	B	C	D	E	F	FILTER SIZE
12PHYB	41	32-1/2	28	31-1/4	28-1/4	28	14 x 28 x 1
16PHYB	51	42-1/2	38	41-1/4	38-1/4	38	14 x 38 x 1
20PHYB	60	51-1/2	47	50-1/4	47-1/4	47	14 x 47 x 1

PHYB PIPE LOCATIONS						
LEFT HAND	X1	Y1	X2	X3	Y3	Y4
3 ROW	5-1/4	7-9/16	8-1/4	---	---	---
4 ROW	5-1/4	7-9/16	8-1/4	---	---	---
6 ROW	5-1/4	7-9/16	8-1/4	---	---	---
3/1 ROW	5-1/4	7-9/16	8-1/4	13-1/4	5-7/16	8-7/16
3/2 ROW	5-1/4	7-9/16	8-1/4	13-1/4	6-1/16	9-1/16
4/1 ROW	5-1/4	7-9/16	8-1/4	13-1/4	6-1/16	9-1/16
4/2 ROW	5-1/4	7-9/16	8-1/4	13-1/4	6-1/16	9-1/16

## PRODUCT DRAWING

FAN COIL UNITS  
MODEL **PHYB**  
NOT FOR CONSTRUCTION

Project Name:  
Location:  
Engineer:  
Contractor:  
For: REFERENCE

Sold To:  
Cust Purch Order #:

Quote Date:  
Rev. Date:  
Form No.:  
Dwg. Lev.:  
Dwg. Scale: NTS



**VALVE CLUSTERS AND INDIVIDUAL COMPONENTS:** (field installed)

**Assembled Valve Clusters:** (factory-assembled and field installed) Components are factory piped together (**order power heads separately**). Contact factory for other valve clusters.

	Right Hand	Left Hand	Description (all 3/4") - For HYB,PHYB
<b>2 pipe</b>	9VBR2BV	9VBL2BV	2-pipe, 2 hand valves only
	9VBR2BC	9VBL2BC	2-pipe, 1 hand valve and circuit setter
	9VBR22B	9VBL22B	2-pipe, one <b>2-way</b> valve body and 2 hand valves
	9VBR22C	9VBL22C	2-pipe, one <b>2-way</b> valve body, 1 hand valve and circuit setter
	9VBR23B	9VBL23B	2-pipe, one <b>3-way</b> valve body and 2 hand valves
	9VBR23D	9VBL23D	2-pipe, one <b>3-way</b> valve body, 2 hand valves and aquastat
	9VBR23C	9VBL23C	2-pipe, one <b>3-way</b> valve body, 1 hand valve and circuit setter
	9VBR23BC	9VBL23BC	2-pipe, one <b>3-way</b> valve body and 3 hand valves
	9VBR23DC	9VBL23DC	2-pipe, one <b>3-way</b> valve body, 3 hand valves and aquastat
<b>4 pipe</b>	9VBR4BV	9VBL4BV	4-pipe, 4 hand valves only
	9VBR42B	9VBL42B	4-pipe, two <b>2-way</b> valve bodies and 4 hand valves
	9VBL42C	9VBL42C	4-pipe, two <b>2-way</b> valve bodies, 2 hand valves and 2 circuit setters
	9VBR43B	9VBL43B	4-pipe, two <b>3-way</b> valve bodies and 4 hand valves
	9VBR43BC	9VBL43BC	4-pipe, two <b>3-way</b> valve bodies and 6 hand valves
<b>Power Heads: (two power heads required for 4-pipe) - For all units</b>			
E50131180		24V	
E50132180		110V/50Hz - 120V/60 Hz	
E50137180		277V	
E50138180		220V/50 Hz – 230V/60 Hz	
<b>Separate Valve Bodies:</b> (order power heads separately)			
E421317	3/4" 2-way - For HYB, PHYB		
E431317	3/4" 3-way - For HYB, PHYB		
<b>Hand Valves:</b> (Combination balance / shut-off) (2 usually req'd per coil)			
CP90	3/4"		
<b>Circuit setters and Strainers</b>			
CP6011	3/4" Circuit setter (Taco)		
CP6031	3/4" Strainer (Kitz)		
945-8	Disconnect (120V)		

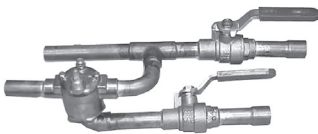

Assembled Valve Cluster (3-way)



CP90

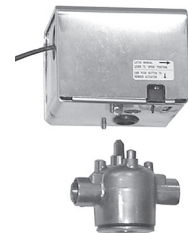

Power Head

Valve Body

**WARNING AVERTISSEMENT ADVERTENCIA**  
 Cancer and Reproductive Harm  
 Cancer et Troubles de l'appareil reproducteur  
 Cáncer y Daño Reproductivo  
[www.P65Warnings.ca.gov](http://www.P65Warnings.ca.gov) LBY0057

# THE AUTOSPEED 24V™ CONTROL PACKAGE

All HBC/PHBC/RHBC/CHBC fan coils are now available with the *Autospeed 24V™* control package option.

The new *Autospeed 24V™* thermostat (part #'s **T200** and **T201**) provides 24V AC single stage temperature control of 2 pipe and 4 pipe fan coil applications. The **T200/T201** thermostat offers maximum comfort and efficiency by automatically selecting the appropriate High, Medium, or Low fan speed, depending on room temperature and thermostat temperature setting. This automatic fan speed control not only brings the room temperature to the desired set point quickly, it maintains the room temperature with the most efficient fan speed selection. Once the desired room temperature is achieved the fan coil operates on low speed for extremely quiet operation.

The fan coil **control board** is a circuit board that provides control of a 3-speed line voltage (120, 208-230, or 277V), (50 or 60 cycle) fan motor. The control board allows the thermostat to control the fan motor even though, by itself, the thermostat does not have the current or voltage rating capability to control the fan motor.

With the *Autospeed 24V™* option, a "Controller Enclosure" is factory installed on each fan coil, which includes the control board, transformer, and service switch.

Continuous or Fan-Cycle operation

**T200** = Manual Changeover

**T201** = Automatic Changeover

## TYPICAL WIRING SCHEMATIC FOR HBC/ PHBC/ CHBC/ RHBC/ HYB/ PHYB

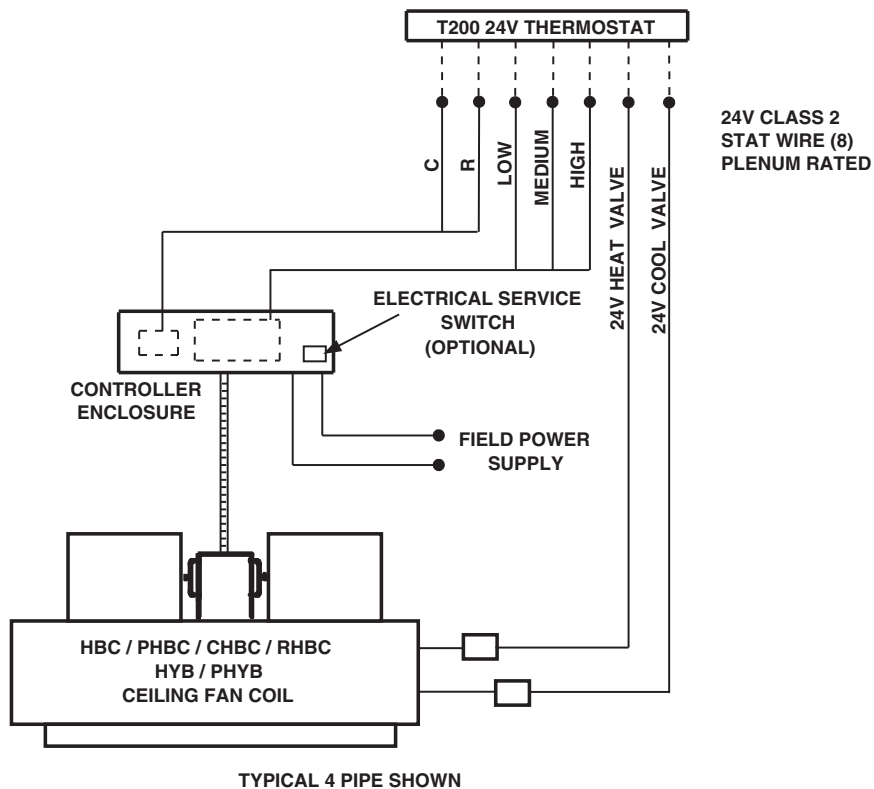

# GUIDE SPECIFICATIONS LO BOY FAN COILS

Furnish and install First Co. horizontal fan coils as indicated on the plans and specifications. Types, sizes, and performance shall be as indicated in the schedule.

## **Basic Unit**

All units shall be manufactured with heavy gauge galvanized steel to resist corrosion.

All piping, drain, and wiring connections shall be readily accessible. Mounting holes with rubber grommets shall be provided to save installation time and expense.

## **Electrical Box**

Unit shall have an electrical box providing a single location for line voltage field wiring connections.

## **Coils**

Coils shall have high efficiency aluminum fins with mechanically expanded 1/2" O.D. copper tubes. All coils shall have a manual air vent. Coil performance shall be as indicated in the schedule.

## **Fan Assembly**

Fans shall be centrifugal, forward curved, and dynamically balanced for smooth, quiet operation. Fan housings shall be fabricated of heavy gauge galvanized steel and be easily removed, thus allowing complete service access to the fans and motors.

## **Motors**

All units shall have (120/1/60) (220/1/50) four speed motors with permanently lubricated sleeve bearings, permanent split capacitor, inherent thermal overload protection with automatic reset, and resilient rubber motor mounts.

## **Drain Pan**

Drain pans shall be insulated to prevent sweating. Drain pans shall be coated to reduce corrosion. Threaded primary and secondary drain connections shall be factory installed.

## **Return Plenum / Filter**

All **PHYB** models shall have factory installed return air plenums. These plenums shall be capable of being field converted from end return to bottom return. One inch throwaway filters shall be installed within the plenums.