



# HX Series

*Horizontal Recessed Ceiling Fan Coil*

Cased and Uncased Available

1-1/2 - 3 Tons Cooling

0 - 10 kW Electric Heat

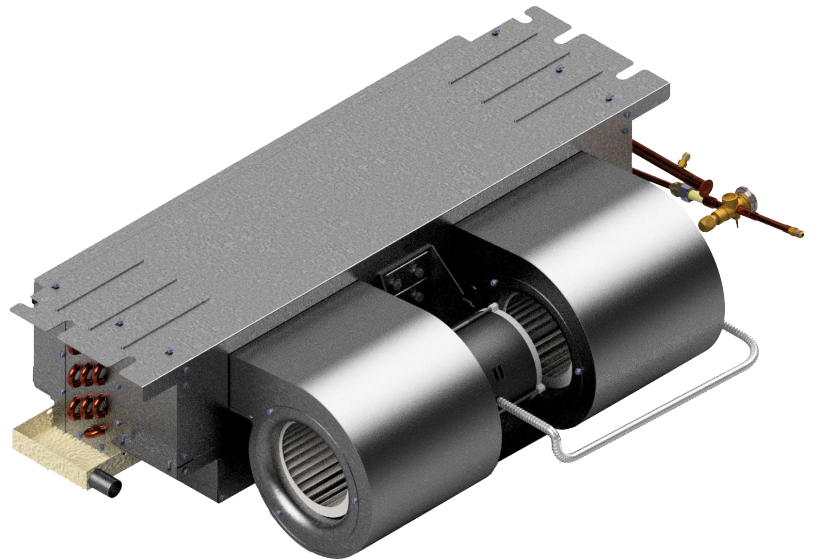

# HX Series

The HX series is compatible with most split-system condensing units and heat pumps (heat pumps with electric heat require field added kit - see P. 3).

All HX fan coils include a 240/24V transformer and are completely prewired with 0 to 10 kW of electric heat. A sloped drain pan allows positive drainage of condensate.

For HX fan coils factory installed within an enclosure, add "-C" after the kW in the model number. For instance, ordering model 18HX5-C will include an 18HX5 factory installed in a # 9EHX01 enclosure. A optional solid or louvered panel can be used with the C model. (see "Enclosures with Ceiling Panels" on P. 4).

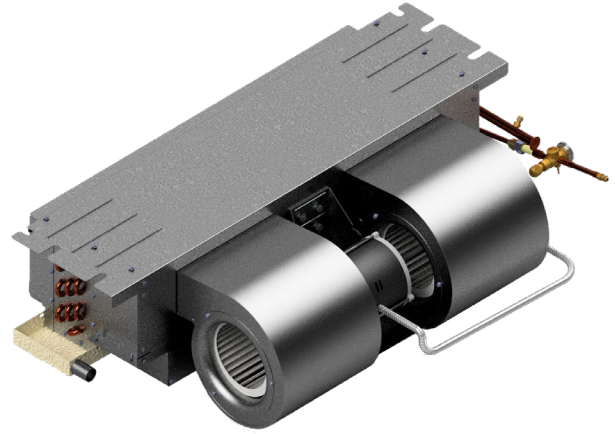

**HX Fan Coil**



**Optional Access Panel**  
(non-louvered shown)  
(see P. 3 for information)

(1) First Co's customer is ultimately responsible for confirming which fan coil models are compatible with selected outdoor unit(s) and which expansion valves (if any) are required. To determine certified indoor/outdoor matches, go to [www.ahridirectory.org](http://www.ahridirectory.org) or [www.firstco.com](http://www.firstco.com).

## STANDARD FEATURES:

- Drain pan has 3/4" NPT primary and secondary (overflow) fittings 240V motor, 24V controls
- Highly efficient copper tube/aluminum fin heating and cooling coils. Cooling coil has a piston-type metering device or factory or field installed R410A TXV (non-bleed type). Contact factory for correct match with outdoor unit.
- Insulated and coated galvanized steel drain pan is sloped for proper drainage.
- Cabinet air leakage is no more than 2% when tested in accordance with ASHRAE 193.

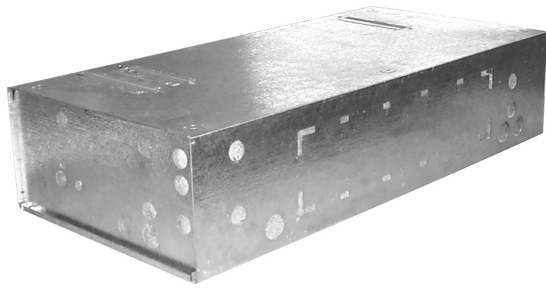

**Optional Insulated Enclosure**  
(see P. 4 for information)



**Matching Access Panel for Enclosure**  
(non-louvered shown)  
(see P. 4 for information)

## OPTIONAL FEATURES:

- Attractive off-white return air / access panel with captive screws (panels can be field painted)
- IAQ filter panels (see P. 4)
- Fully insulated enclosure with matching ceiling panel (enclosure can be pre-installed). Also allows for ducted return air.
- Heat pump kit - for all HX models with electric heat (#942-1) (field installed)
- Factory or field installed R410 TXV (non-bleed type)
- Condensate overflow switch (# SS3) (Field installed)
- Enclosure (Cap" kit - for above the ceiling installation (P. 7)
- Optional bolt on Merv-13 rated filter box for cased units.

# HX Series

## 1-1/2 THROUGH 3 TONS

In keeping with its policy of continuous progress and product improvement, First Co. reserves the right to make changes without notice.



Approved for installation with 0" clearance to combustibles materials (See P. 4 for Model Numbers)

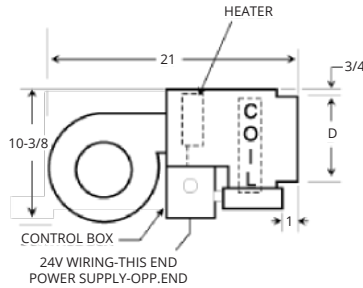

SUCTION LINE  
5/8 SWEAT: 18, 19, 24HX  
7/8 SWEAT: 20, 25-37HX  
LIQUID LINE-3/8 SWEAT

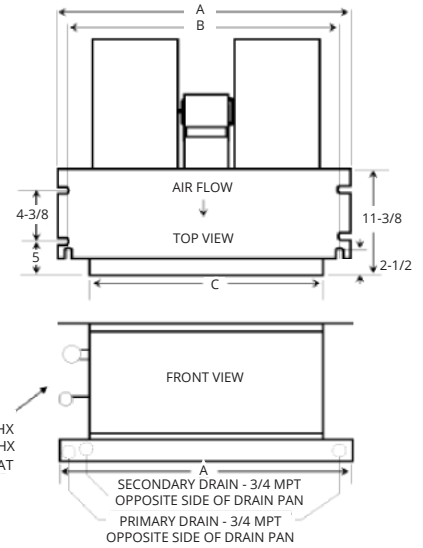

PERFORMANCE DATA											
UNIT MODEL	NOM. CFM	NOM. COOL BTUH	HEAT Kw			TOTAL AMPS	MIN. CIR. AMPACITY		(2) MAX FUSE		
			208V	240V	BTUH		208V	240V	208V	240V	
18HX -5 -6	600	18,000	2.3	5	17,000	22.8	25	30	25	30	
			3.8	6	20,500	27.0	30	35	30	35	
19HX & 20HX -0-51 -3 -5 -6 -8	600	18,000	---	---	---	1.0	2	2	15	15	
			2.3	3	10,200	13.5	15	18	15	20	
			3.8	5	17,000	21.8	24	30	25	30	
			4.5	6	20,500	26.0	29	35	30	35	
24, 25HX & 26, 28HX -3 -5 -6 -8 -10	800	24,000	---	---	---	2.0	3	3	15	15	
			2.3	3	10,200	14.5	16	20	20	20	
			3.8	5	17,000	22.8	25	30	25	30	
			4.5	6	20,500	27.0	29	35	30	35	
			6.0	8	27,300	35.3	39	47	40	50	
30, 31HX & 32HX -8 -10	1000	30,000	---	---	---	2.0	3	3	15	15	
			2.3	3	10,200	14.5	16	20	20	20	
			3.8	5	17,000	22.8	25	30	25	30	
			4.5	6	20,500	27.0	29	35	30	35	
			6.0	8	27,300	35.3	39	47	40	50	
36HX & 37HX -8 -10	1200	36,000	---	---	---	2.8	4	4	15	15	
			2.3	3	10,200	15.3	18	20	20	20	
			3.8	5	17,000	23.6	27	30	30	30	
			4.5	6	20,500	27.8	31	35	35	35	
			6.0	8	27,300	36.1	40	46	40	50	
			7.5	10	34,100	44.5	49	56	50	60	

(1) All BTUH heating ratings at 240V - derate heating capacities by 25% for 208V  
(2) Maximum fuse or HACR-type circuit breaker.

PHYSICAL DIMENSIONS				
MODEL	A	B	C	D
18HX 19HX 24HX	37-1/4	34-11/16	30	6-1/2
20HX 25HX 30HX	43-1/4	40-11/16	36	6-1/2
26HX 31HX 36HX	49-1/4	46-11/16	42	6-1/2
28HX 32HX 37HX	56-1/4	53-11/16	49	6-1/2

EXPANSION VALVE KITS (Heat pump or cooling only)		
PART NO.	TYPE	FOR
9EVR410-1	R410A	18 - 37HX (1-1/2 - 3 TON)

NOTES:

- (1) Above expansion valve kits are approved for both cooling only (non heat pump) or heat pump applications.
- (2) Valves are non-bleed type. Field added. Hard start kit may be required
- (3) Valves have screw-on connections.
- (4) Field installed.

BLOWER DATA								
UNIT MODEL	MOTOR HP (240V)	CFM vs. EXTERNAL STATIC PRESSURE						
		0.00	0.05	0.10	0.15	0.20	0.25	0.30
18HX	1/8	810	775	740	705	670	640	610
19HX	1/8	820	785	750	715	680	650	620
20HX	1/8	850	815	780	745	710	670	630
24, 28HX	1/4	910	875	840	805	770	730	690
25HX	1/4	930	895	860	825	790	750	710
26HX	1/4	960	925	890	850	810	770	730
30, 31HX	1/4	1110	1075	1040	990	940	900	860
32HX	1/4	1170	1140	1110	1075	1040	1000	960
36HX	1/3	1410	1370	1330	1290	1250	1210	1170
37HX	1/3	1460	1420	1380	1340	1300	1250	1200

(1) Add .05 static when enclosure is used.

HEAT PUMP KIT (FIELD INSTALLED)	
PART NO.	DESCRIPTION
942-1	KIT FOR HX MODELS WITH ELECTRIC HEAT

NOTE: Heat pump kit must be field installed for all HX models with electric heat. 0 kW models do not require kit. **Contact the factory for compatibility match with condensing unit.**

## CEILING ACCESS PANELS - For HXs installed without enclosure



# 965-1, 966-1,  
967-1, 967-7



# 965, 966, 967, 967-6  
(Louvers may differ from picture)  
Louvered panels accept 20x20x1"

### STANDARD PANELS



# 965-M8  
(accepts 1-20x30x1 filter)  
# 966-M8, 967-M8  
(accepts 2-20x20x1 filter)  
# 967-6-M8  
(accepts 2-20x25x1 filter)  
(GlasFloss® Industries Series)

### IAQ PANELS

CEILING ACCESS PANELS							
FOR MODEL	PANEL NO. (STD.)	PANEL NO. (IAQ)	DESCRIPTION	CEILING PANEL OPENING		PANEL FRAME DIMS. (OUTSIDE)	
18, 19, 24HX	965	965-M8	LOUVERED	24-1/2	40	27-1/2	43
	965-1	NA	NON-LOUVERED	24-1/2	40	27-1/2	43
20, 25, 30HX	966	966-M8	LOUVERED	24-1/2	46	27-1/2	49
	966-1	NA	NON-LOUVERED	24-1/2	46	27-1/2	49
26, 31, 36HX	967	967-M8	LOUVERED	24-1/2	52-1/2	27-1/2	55-1/2
	967-1	NA	NON-LOUVERED	24-1/2	52-1/2	27-1/2	55-1/2
28, 32, 37HX	967-6	967-6-M8	LOUVERED	24-1/2	60	27-1/2	63
	967-7	NA	NON-LOUVERED	24-1/2	60	27-1/2	63



## ENCLOSURES WITH CEILING PANELS - Panels are sold separately for cased and uncased units.

CEILING PANEL / ENCLOSURE INFORMATION											
FOR MODEL	ENCLOSURE NO.	ENCLOSURE DIMENSIONS			PANEL NO. (STD.)	PANEL NO. (IAQ)	DESCRIPTION (2)	CEILING PANEL OPENING		PANEL FRAME DIMS (OUTSIDE)	
		H	W	D				W	L	W	L
18, 19, 24HX	9EHX01	11	39-3/4	23-7/8	965	965-M8*	LOUVERED	24-1/2	40	27-1/2	43
					965-1	NA	NON-LOUVERED	24-1/2	40	27-1/2	43
20, 25, 30HX	9EHX02	11	45-3/4	23-7/8	966	966-M8*	LOUVERED	24-1/2	46	27-1/2	49
					966-1	NA	NON-LOUVERED	24-1/2	46	27-1/2	49
26, 31, 36HX	9EHX03	11	51-3/4	23-7/8	967	967-M8*	LOUVERED	24-1/2	52-1/2	27-1/2	55-1/2
					967-1	NA	NON-LOUVERED	24-1/2	52-1/2	27-1/2	55-1/2
28, 32, 37HX	9EHX04	11	58-3/4	23-7/8	967-6	967-6-M8*	LOUVERED	24-1/2	60	27-1/2	63
					967-7	NA	NON-LOUVERED	24-1/2	60	27-1/2	63

#### NOTES:

(1) Panels do not mount to cases. See framing detail on page 5

(2) Panels are sold separately from cases or cased units

(\* ) Add -2 to end of panel number for panel that accepts 2" filter.

(See Panel Pictures Above)

# ENCLOSURES WITH CEILING PANELS (CONT.) - Panels are sold separately for cased and uncased units.

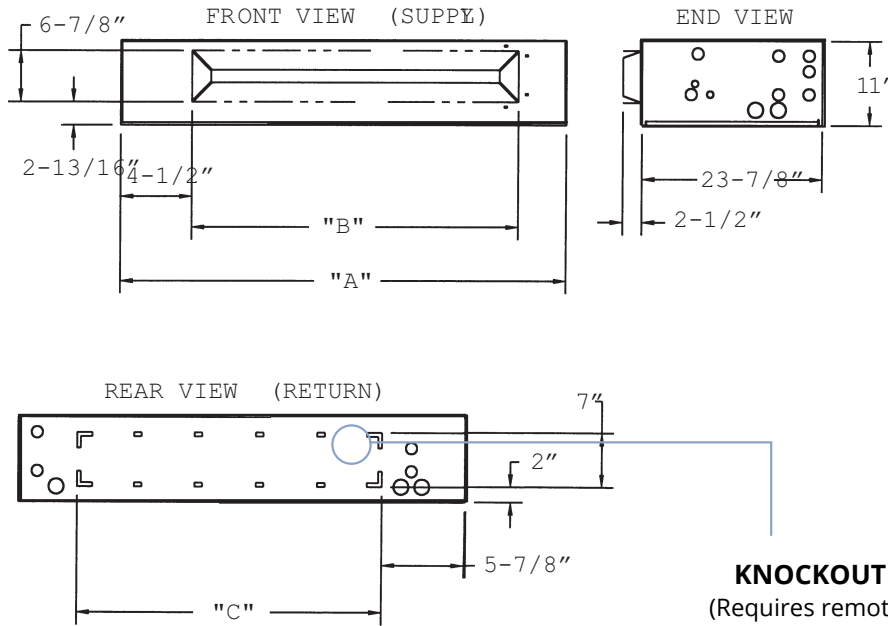

Picture shown is enclosure with installed HX (Available from the factory as a complete unit)

ENCLOSURE DIMENSIONS				
FOR MODEL	ENCLOSURE NO.	A	B	C
18, 19, 24HX	9EHX01	39-3/4	30-5/8	28
20, 25, 30HX	9EHX02	45-3/4	36-5/8	34
26, 31, 36HX	9EHX03	51-3/4	42-5/8	40
28, 32, 37HX	9EHX04	58-3/4	50	46-3/4

# MERV RATED FILTER BOX FOR ENCLOSURES

## SINGLE FILTER FOR SIZE 18-30HX AND 9EHX01,9EHX02

### PART NUMBER

### 1000-1

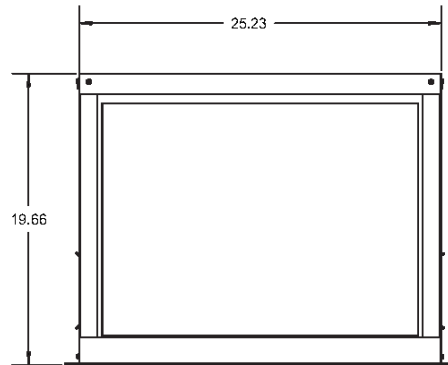
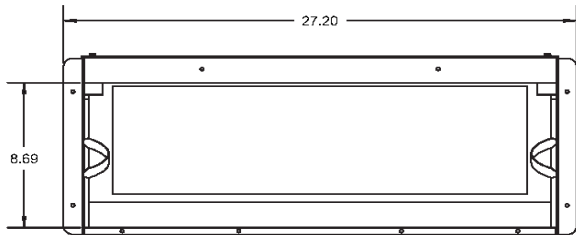
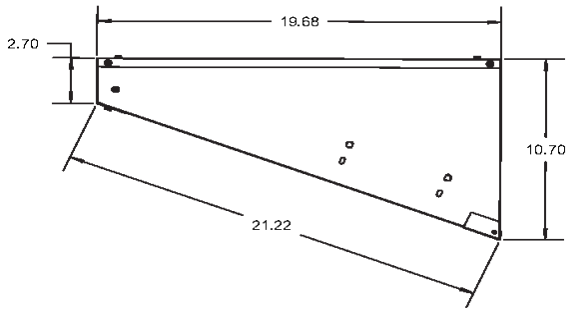

## DOUBLE FILTER FOR SIZE 31-37HX AND 9EHX03,9EHX04

### PART NUMBER

### 1000-2

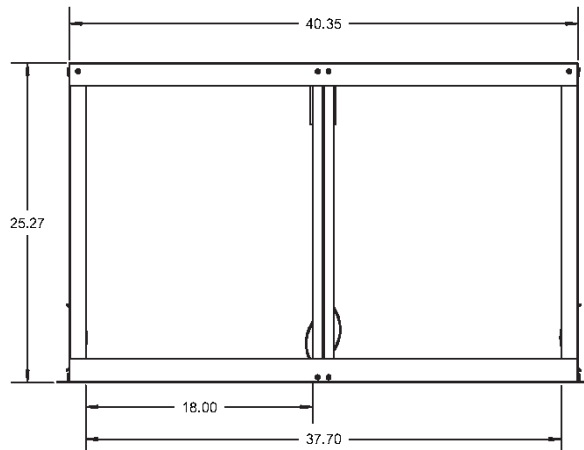
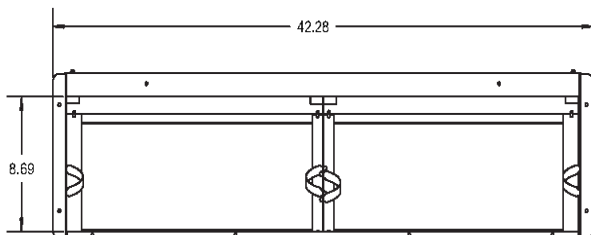
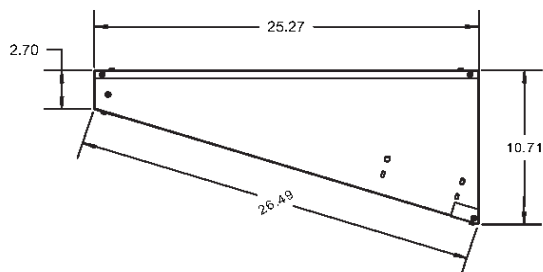

# HX Series

1-1/2 THROUGH 3 TONS

## MODEL NUMBERS

MODEL SIZE (BTU)	UNCASED (NO ENCLOSURE)		FACTORY INSTALLED ENCLOSURE	
	MODEL (PISTON)	MODEL (R410 TXV)	MODEL (PISTON)	MODEL (R410 TXV)
18,000	18HX(*)	18HX(*) R410 TXV	18HX(*)-C	18HX(*)-C R410 TXV
18,000	19HX(*)	19HX(*) R410 TXV	19HX(*)-C	19HX(*)-C R410 TXV
18,000	20HX(*)	20HX(*) R410 TXV	20HX(*)-C	20HX(*)-C R410 TXV
24,000	24HX(*)	24HX(*) R410 TXV	24HX(*)-C	24HX(*)-C R410 TXV
24,000	25HX(*)	25HX(*) R410 TXV	25HX(*)-C	25HX(*)-C R410 TXV
24,000	26HX(*)	26HX(*) R410 TXV	26HX(*)-C	26HX(*)-C R410 TXV
24,000	28HX(*)	28HX(*) R410 TXV	28HX(*)-C	28HX(*)-C R410 TXV
30,000	30HX(*)	30HX(*) R410 TXV	30HX(*)-C	30HX(*)-C R410 TXV
30,000	31HX(*)	31HX(*) R410 TXV	31HX(*)-C	31HX(*)-C R410 TXV
30,000	32HX(*)	32HX(*) R410 TXV	32HX(*)-C	32HX(*)-C R410 TXV
36,000	36HX(*)	36HX(*) R410A TXV	36HX(*)-C	36HX(*)-C R410 TXV
36,000	37HX(*)	37HX(*) R410 TXV	37HX(*)-C	37HX(*)-C R410 TXV

All TXV's are approved for cooling only or heat pump operation (non-bleed type).

(\*) = kW HEAT

**NOTE:**

Expansion valve requirement depends on the selected outdoor unit. Go to: [www.firstco.com](http://www.firstco.com) or contact the factory for assistance.

## ENCLOSURE INSTALLATION SUPPORT FRAMING

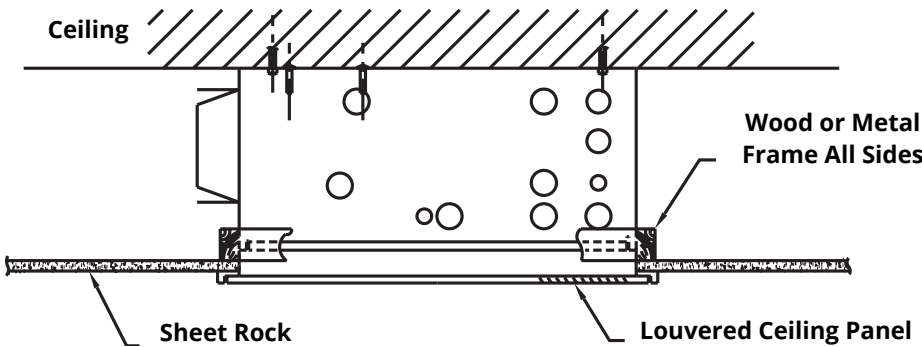

## ENCLOSURE CONNECTION LOCATIONS

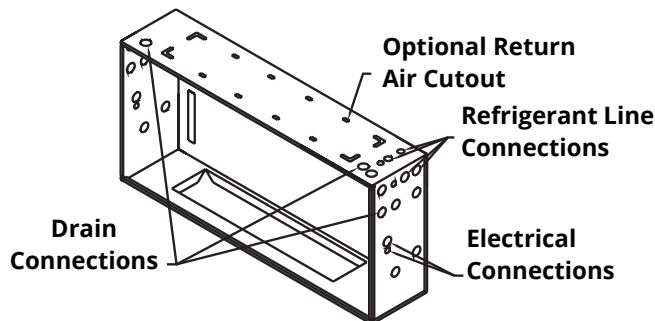

CAP KIT - FOR INSTALLATION ABOVE A SUSPENDED CEILING		
PART NO.	FITS ENCLOSURE NO.	FOR UNIT MODEL
9PHX01	9EHX01	18, 19, 24HX-C
9PHX02	9EHX02	20, 25, 30HX-C
9PHX03	9EHX03	26, 31, 36HX-C
9PHX04	9EHX04	28, 32, 37HX-C

NOTES:

- (1) Cap kit is an insulated panel that covers the entire bottom opening of the enclosure (requires ducted return)
- (2) Cap kit would be used in lieu of the ceiling panel and mounts to the case.





FIRST CO.  
P.O. BOX 270969 - DALLAS, TEXAS 75227  
PH. (214) 388-5751 | FAX (214) 388-2255  
WWW.FIRSTCO.COM

**MAY 2024**