



HRCX

Commercial Water Source Heat Pump

Vertical Hi-Rise

Single Stage Series

3/4 Thru 3 Tons

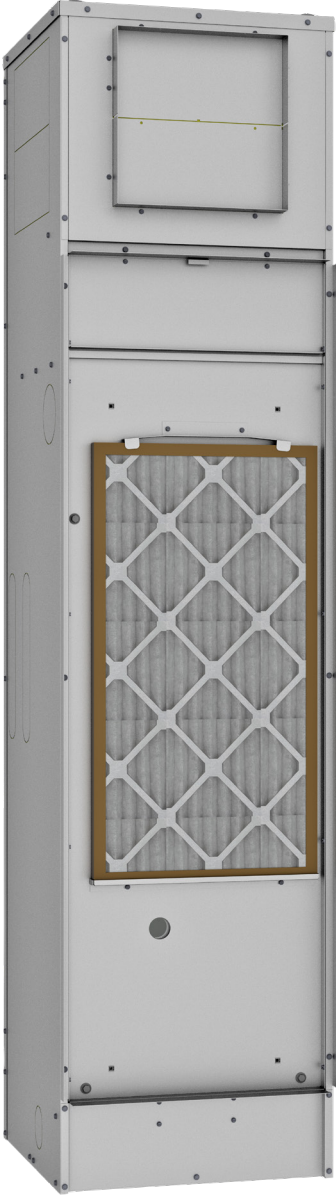

TABLE OF CONTENTS

NOMENCLATURE – HRCX CHASSIS3

NOMENCLATURE – HRCX CABINET4

SERIES FEATURES5

PHYSICAL DATA7

ELECTRICAL & CAPACITY DATA8

BLOWER PERFORMANCE9

DIMENSIONS 10

PRIMARY/SECONDARY CABINET INSTALLATION 14

VALVE PACKAGES AND ACCESSORIES..... 15

ACCESS RETURN PANEL 16

CABINET PLATFORM SPECIFICATIONS 17

DISCHARGE AIR OPENINGS 18

LOUVERS 19

SPECIFICATIONS GUIDE – HRCX CHASSIS.....20

PACKAGING AND SHIPPING OPTIONS23

In keeping with its policy of continuous progress and product improvement, First Co. reserves the right to make changes without notice.

NOMENCLATURE

HRCX CHASSIS

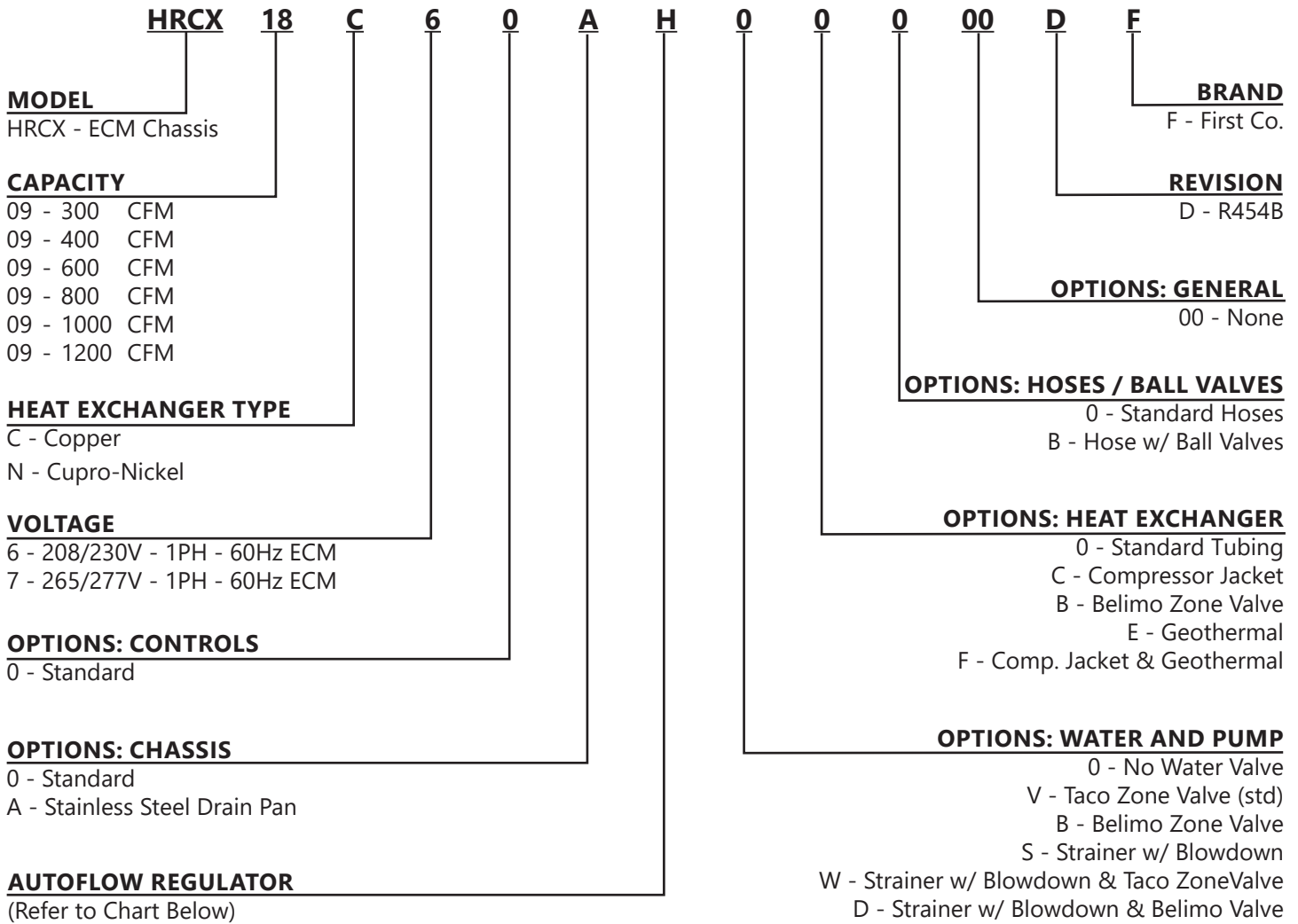

AUTO-FLOW REGULATOR (GPM) CODE							
TUBE		5/8" SWEAT		7/8" SWEAT			
UNIT		09	12	18	24	30	36
0	0	No Flow Regulator					
C	1.5	1.5					
D	2.0	2.0	2.0				
E	2.5	2.5	2.5				
F	3.0	3.0	3.0	3.0			
G	3.5		3.5	3.5			
H	4.0			4.0	4.0		
I	4.5			4.5	4.5		
J	5.0			5.0	5.0	5.0	
K	5.5				5.5	5.5	
L	6.0				6.0	6.0	6.0
M	6.5				6.5	6.5	6.5
N	7.0				7.0	7.0	7.0
P	7.5					7.5	7.5
Q	8.0					8.0	8.0
T	9.0						9.0
V	10.0						10.0

NOMENCLATURE

HRCX CABINET

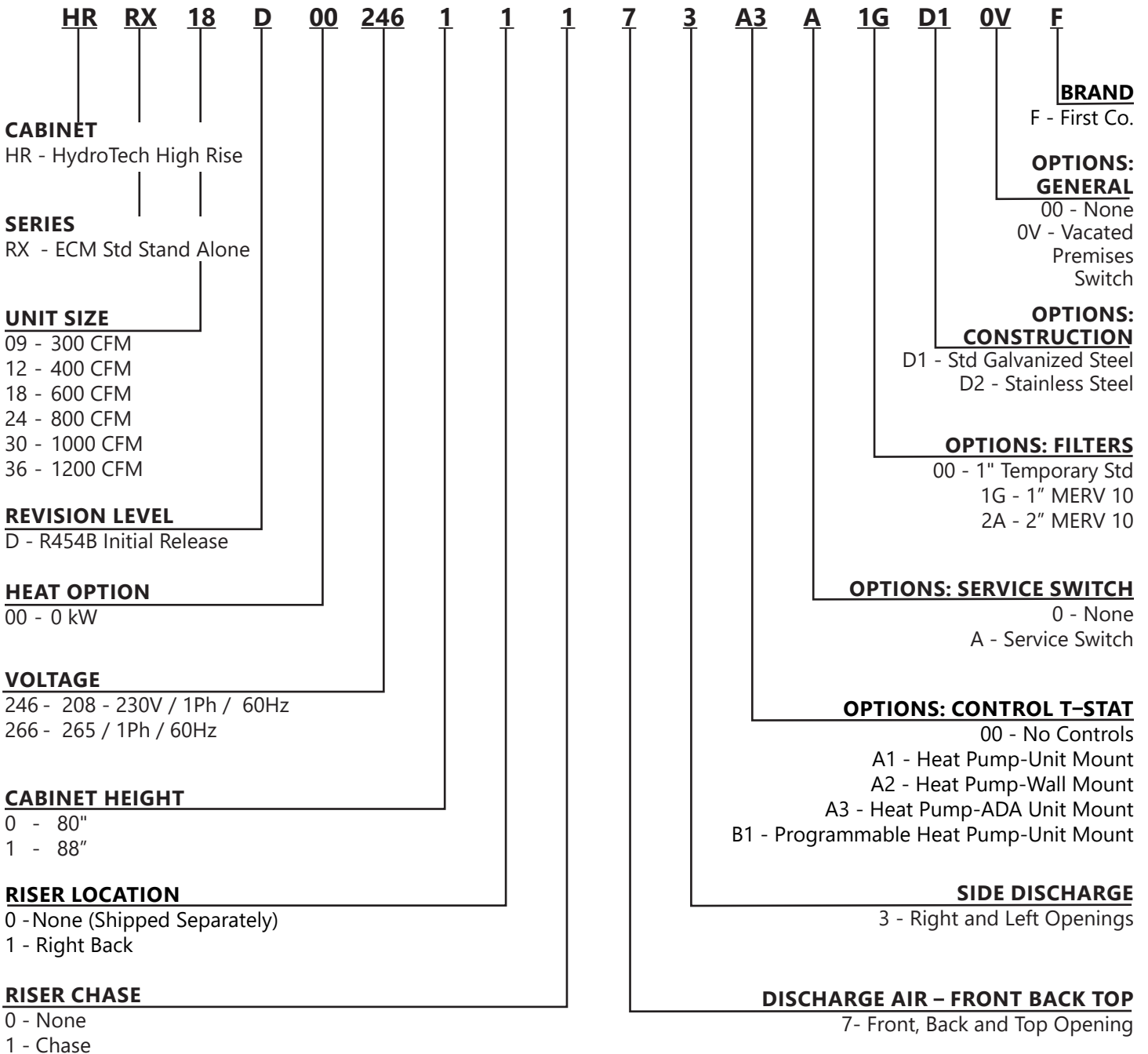

HRCX SERIES

COMMERCIAL WATER SOURCE HEAT PUMP

VERTICAL HI-RISE

Available sizes for the vertical high-rise water-source heat pumps are 3/4-ton thru 3-ton. Units are floor mounted and designed to be furred in behind drywall to blend into the space. Units' consist of separate components - cabinet behind finished wall and slide in refrigeration chassis.

For multi-story building applications, the units may be stacked above each other by floor to minimize piping and electrical cost. Copper piping risers can be factory mounted to the rear or sides of the cabinet or can be fabricated and shipped in advance so the riser columns can be completely assembled, pressured tested, filled, and water circulated. This allows floor by floor completion and occupancy before the building is complete.

The high-rise configuration is often used in hotels, dorms and assisted living facilities where a single unit could provide comfort to a single or multiple room dwelling. Because the units are mounted directly in the space, ductwork is optional.

All water-source heat pumps are run tested with water and quality certified prior to leaving the factory. This assures quality standards from controls, water, refrigeration, and aesthetics to the building owner and installing contractor.

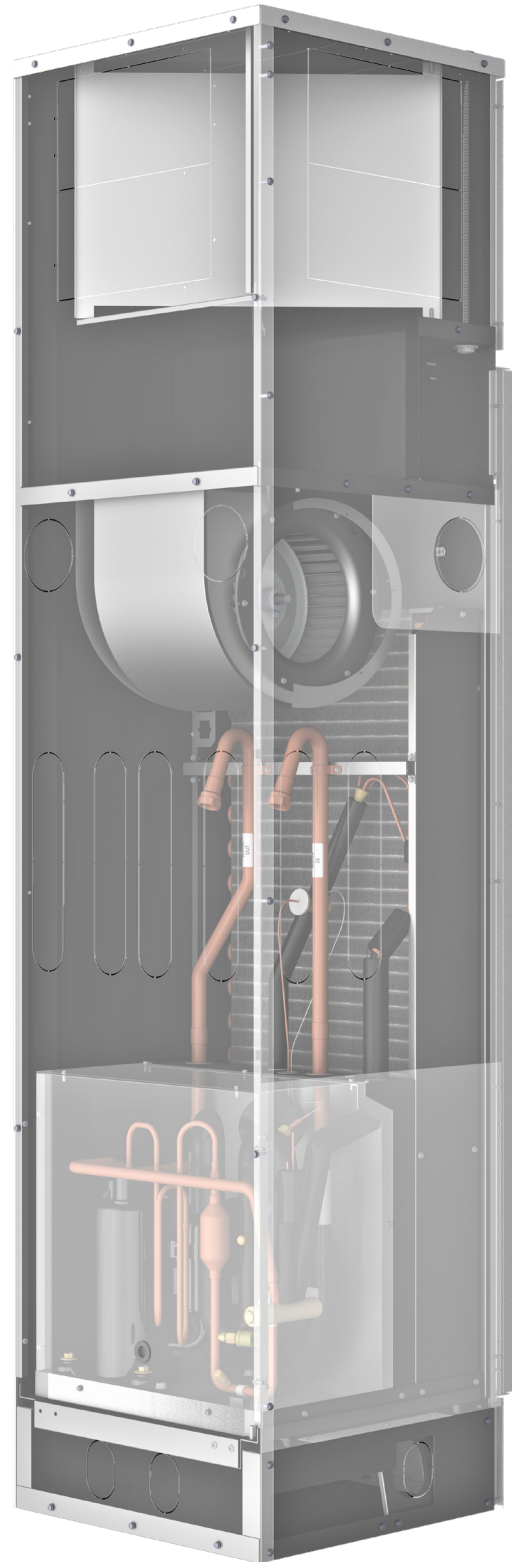

HRCX SERIES

COMMERCIAL WATER SOURCE HEAT PUMP

HRCX MODELS



**HRCX CHASSIS AND
HR CABINET**

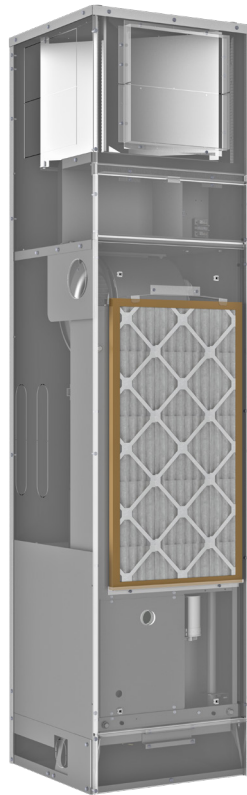

**SLIDE IN HRCX CHASSIS
TO HR CABINET**



**HRCX CHASSIS FULLY INSULATED PIPING
FOR GROUND LOOP APPLICATIONS**

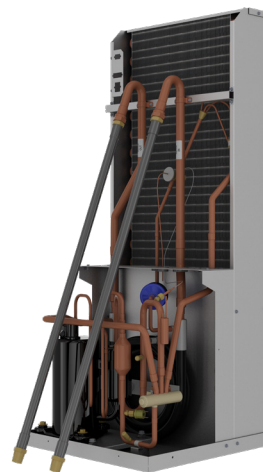

**HRCX CHASSIS UN-INSULATED PIPING
FOR STANDARD WATER CONDITIONS**

HRCX SERIES

COMMERCIAL WATER SOURCE HEAT PUMP

PHYSICAL DATA

MODEL - SIZE	HRCX	9	12	18	24	30	36
Compressor (1 Each)	1 Each	Rotary			Scroll		
Refrigerant Type		R410A					
Factory Charge	(Lb.) [kg]	1.76 [0.8]	2 [0.9]	2.39 [1.08]	3.2 [1.45]	3.1 [1.4]	3.12 [1.41]
A2L Sensor and Mitigation	YES/NO	NO	NO	NO	NO	NO	NO
Minimum Room Area	Ft ² [m ²]	N/A	N/A	N/A	N/A	N/A	N/A
Minimum Air Flow	CFM [m ³ /hr]	N/A	N/A	N/A	N/A	N/A	N/A
Motor	Type	ECM					
	Speeds	Multiple					
	HP [kw]	1/4 [.18]	1/4 [.18]	1/3 [.24]	1/3 [.24]	1/2 [.37]	1/2 [.37]
Blower Wheel (Dia. x W)	(Dia x W) in. [cm]	6.75 x 7 [17.15 x 17.78]		9 x 7 [22.86 x 17.78]		10 x 8 [25.4x20.32]	
COAX Volume	(US Gallons)	0.116	0.116	0.144	0.544	0.544	0.544
Condenser Water Connections	(in)	1/2	1/2	3/4	1	1	1
Condensate Connection	I.D.(in) / O.D.(in)	7/8 / 1-1/8					
Air Coil Dimension	(W x H) in. [cm]	14 x 28 [5.5 x 11.0]			18 x 30 [7.1 x 11.8]		
Standard TA Filter 1"	(W x H) in. [cm]	16 x 30 [6.3 x 11.8]			20 x 32 [7.9 x 12.6]		
Operating Weight		Weight					
Chassis	Lb. [kg]	125 [57]	128 [58]	131 [59]	182 [83]	185 [84]	188 [85]
80" Cabinet		128 [58]			173 [78]		175 [79]
88" Cabinet		143 [65]			188 [85]		190 [86]

HRCX SERIES

COMMERCIAL WATER SOURCE HEAT PUMP

ELECTRICAL DATA

ECM - ELECTRICAL DATA 208/230V-1-60							
MODEL NUMBER	VOLTAGE	COMPRESSOR		BLOWER		MIN. CIRCUIT AMPACITY	MAX. CIRCUIT PROTECTION
		RLA	LRA	FLA	HP		
HRCX09	208/230V-1-60	3.97	22	2.3	1/4	7	15
	265V-1-60	3.97	23	2.3	1/4	7	15
HRCX12	208/230V-1-60	4.7	25	2.3	1/4	9	15
	265V-1-60	3.91	21	2.3	1/4	8	15
HRCX18	208/230V-1-60	6.6	36	2.8	1/3	12	15
	265V-1-60	5.45	36	2.6	1/3	11	15
HRCX24	208/230V-1-60	11.3	63	2.8	1/3	17	25
	265V-1-60	8.09	45	2.6	1/3	14	20
HRCX30	208/230V-1-60	12.8	71	4.1	1/2	21	30
	265V-1-60	10.4	68	3.6	1/2	18	25
HRCX36	208/230V-1-60	15.5	86	4.1	1/2	24	35
	265V-1-60	10.26	55	3.6	1/2	19	30

CAPACITY DATA

PERFORMANCE DATA - CERTIFIED AT AHRI/ISO 13256-1 CONDITIONS														
MODEL NUMBER	NOM. CFM (ECM)	GPM	WATER LOOP (EWT)				Ground Water (EWT)				Ground Water (EWT)			
			86°F		68°F		59°F		50°F		77°F		32°F	
			COOLING	EER	HEATING	COP	COOLING	EER	HEATING	COP	COOLING	EER	HEATING	COP
HRCX09	350	2.3	9,600	16.0	10,500	5.0	11,500	26.5	8,800	4.5	10,000	19.0	6,800	3.6
HRCX12	400	2.6	11,500	15.0	12,800	4.6	13,000	25.0	10,500	4.1	11,800	18.0	8,000	3.6
HRCX18	600	4.5	18,000	14.5	20,000	4.8	20,000	22.5	16,000	4.1	18,000	17.1	13,000	3.6
HRCX24	800	6.0	24,000	16.5	28,000	5.0	26,000	26.5	22,000	4.4	24,000	19.0	17,000	3.6
HRCX30	900	7.5	27,000	16.0	31,000	4.6	30,000	23.5	25,000	4.1	28,000	18.0	20,000	3.6
HRCX36	1125	9.0	34,000	14.5	38,000	4.7	35,500	21.6	31,500	4.1	34,100	17.1	25,000	3.6

AHRI/ISO 13256-1 Conditions DATA AT 208V-230V/1/60

Cooling Entering Air Temperature = 80.6°F WB / 66.2°F DB
 Cooling Entering Fluid Temperature = 86°F

Heating: Entering Air Temperature = 68°F DB / 59°F WB
 Heating Entering Air Temperature = 68°F

HRCX SERIES

COMMERCIAL WATER SOURCE HEAT PUMP

BLOWER PERFORMANCE

ECM BLOWER DATA							BLOWER SETTINGS			
MODEL NUMBER	FAN SPEED	CFM vs EXTERNAL STATIC PRESSURE					COOLING			HEATING
		0.1	0.2	0.3	0.4	0.5	DEHUM ¹		NORMAL	
							0 - 10	10+		
HRCX09*	T3	430	410	380	360	340		X	X	X
	T2	360	330	300	280	250	X			
	T1	290	260	230						
HRCX12*	T3	490	460	440	420	410		X	X	X
	T2	390	360	340	310	290	X			
	T1	310	280	250	230					
HRCX18*	T3	770	740	700	660	610		X	X	X
	T2	650	620	590	560	530	X			
	T1	550	520	490	450	410				
HRCX24*	T3	940	910	870	840	800		X	X	X
	T2	840	810	770	740	700	X			
	T1	720	690	650	610	560				
HRCX30*	T3	1260	1210	1140	1060	970		X	X	X
	T2	1080	1050	1020	980	940	X			
	T1	990	960	930	900	870				
HRCX36*	T3	1300	1230	1150	1080	990		X	X	X
	T2	1260	1210	1140	1060	970	X			
	T1	1080	1050	1020	980	940				
CFM rated at 208V for 208-230V units										

HRCX SERIES

COMMERCIAL WATER SOURCE HEAT PUMP

DIMENSIONS

UNIT SIZE: 09, 12, AND 18 – 80" TALL CABINET

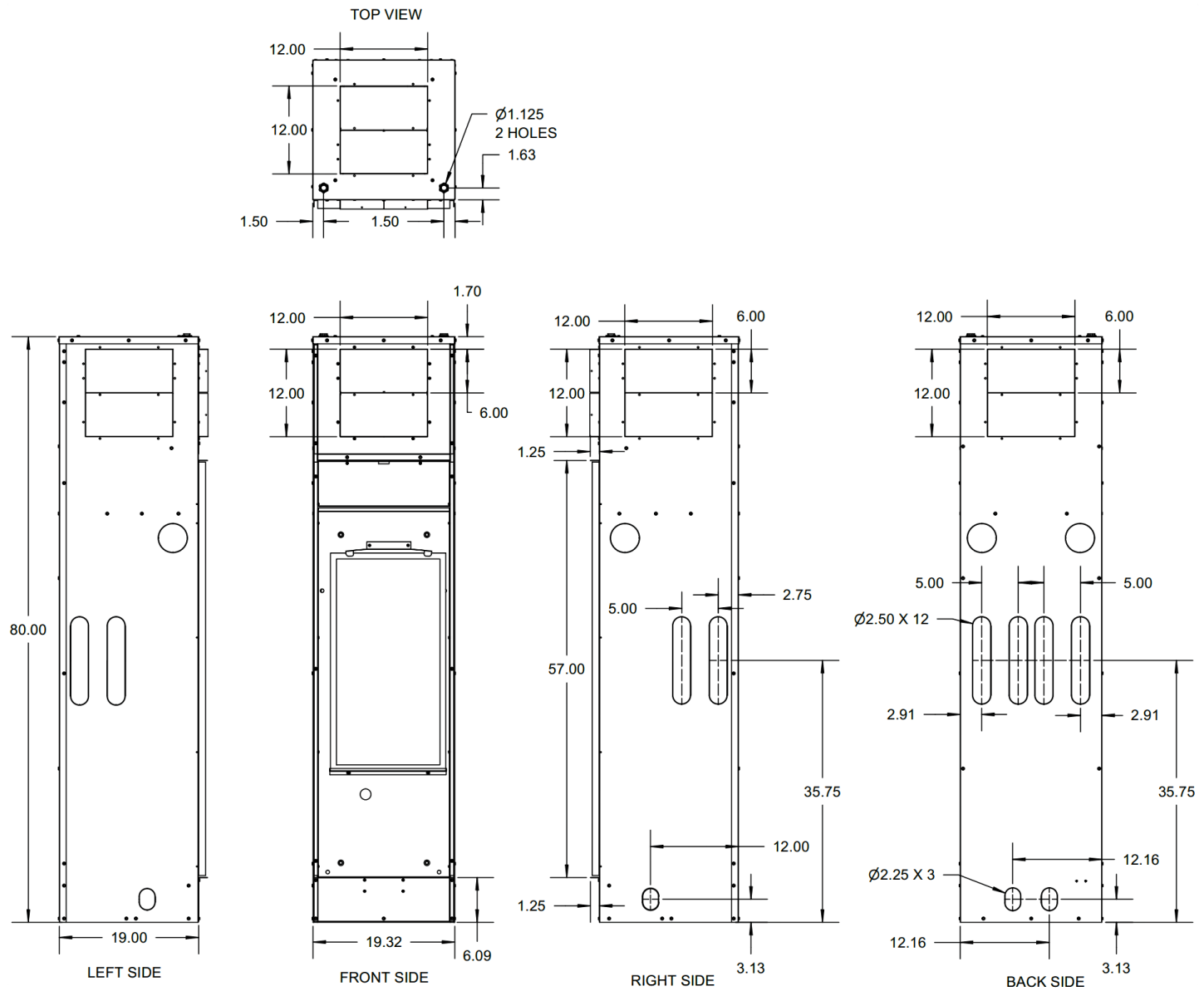

HT Vertical High Rise Heat Pump Cabinet

NOTES:

1. All dimensions are in inches.
2. The return air/control box side is defined as front of cabinet. Supply air K.O.'s and riser K.O.'s are on all panels. Supply air grilles can be on any side except riser side.
3. Units with 24v surface mount T/stat option have 2x4 box factory installed in horizontal position. Contractor must turn box before dry walling if customer is using vertical thermostat type.
4. Cabinet shown is Style 3, risers back right.
5. Supply air K.O.'s have to be field removed.
6. Supply air angles are shipped loose. Break off for 6" or 8". Position inside and attach with screws.
7. Service clearances: Front requires 24" from finished wall plus 4" added to cabinet width.

HRCX SERIES

COMMERCIAL WATER SOURCE HEAT PUMP

DIMENSIONS

UNIT SIZE: 24, 30, AND 36 – 80" TALL CABINET

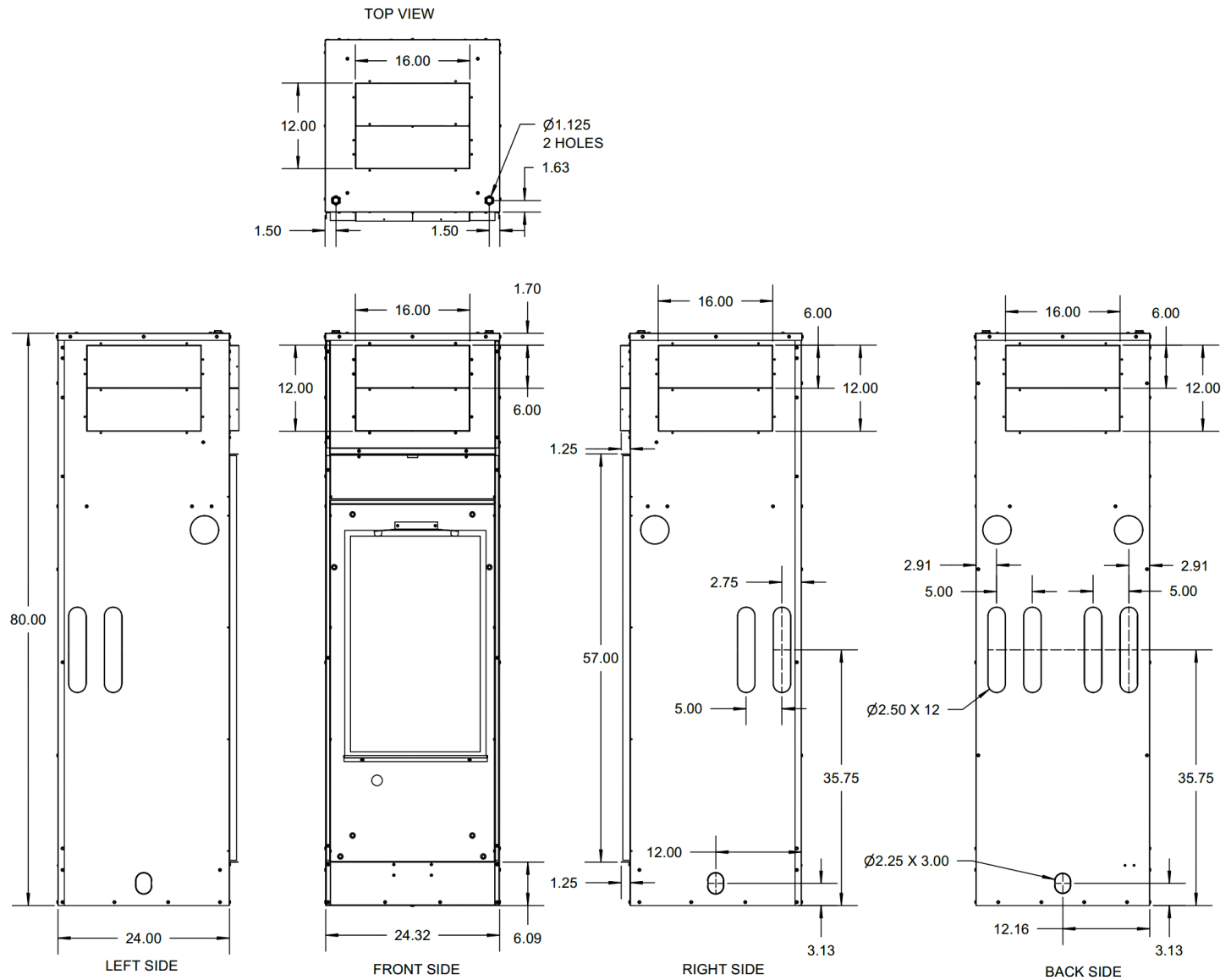

HT Vertical High Rise Heat Pump Cabinet

NOTES:

1. All dimensions are in inches.
2. The return air/control box side is defined as front of cabinet. Supply air K.O.'s and riser K.O.'s are on all panels. Supply air grilles can be on any side except riser side.
3. Units with 24v surface mount T/stat option have 2x4 box factory installed in horizontal position. Contractor must turn box before dry walling if customer is using vertical thermostat type.
4. Cabinet shown is Style 3, risers back right.
5. Supply air K.O.'s have to be field removed.
6. Supply air angles are shipped loose. Break off for 6" or 8". Position inside and attach with screws.
7. Service clearances: Front requires 24" from finished wall plus 4" added to cabinet width.

HRCX SERIES

COMMERCIAL WATER SOURCE HEAT PUMP

DIMENSIONS

UNIT SIZE: 09, 12, AND 18 – 88" TALL CABINET

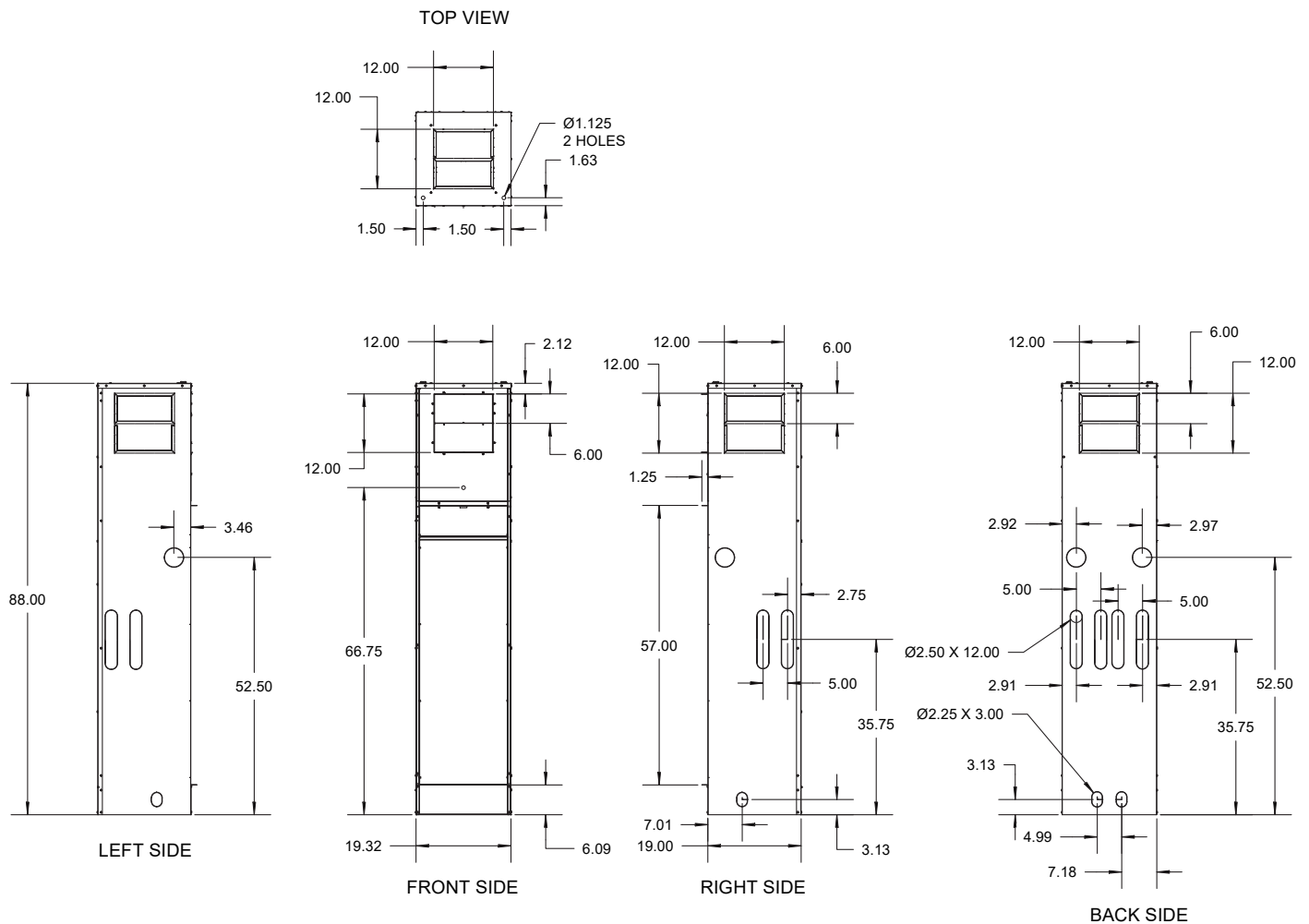

HT Vertical High Rise Heat Pump Cabinet

NOTES:

1. All dimensions are in inches.
2. The return air/control box side is defined as front of cabinet. Supply air K.O.'s and riser K.O.'s are on all panels. Supply air grilles can be on any side except riser side.
3. Units with 24v surface mount T/stat option have 2x4 box factory installed in horizontal position. Contractor must turn box before dry walling if customer is using vertical thermostat type.
4. Cabinet shown is Style 3, risers back right.
5. Supply air K.O.'s have to be field removed.
6. Supply air angles are shipped loose. Break off for 6" or 8". Position inside and attach with screws.
7. Service clearances: Front requires 24" from finished wall plus 4" added to cabinet width.

HRCX SERIES

COMMERCIAL WATER SOURCE HEAT PUMP

DIMENSIONS

UNIT SIZE: 24, 30, AND 36 – 88" TALL CABINET

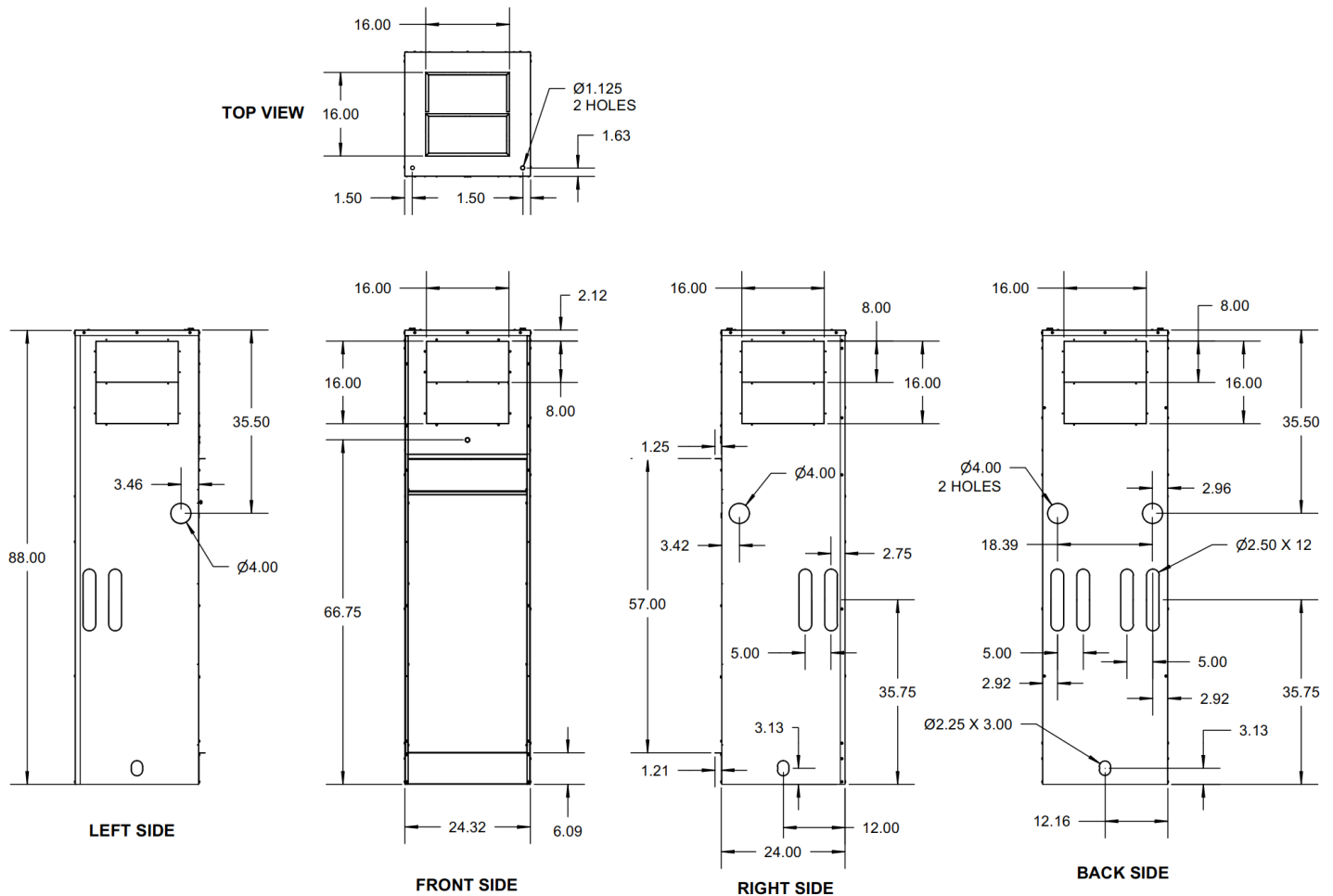

HT Vertical High Rise Heat Pump Cabinet

NOTES:

1. All dimensions are in inches.
2. The return air/control box side is defined as front of cabinet. Supply air K.O.'s and riser K.O.'s are on all panels. Supply air grilles can be on any side except riser side.
3. Units with 24v surface mount T/stat option have 2x4 box factory installed in horizontal position. Contractor must turn box before dry walling if customer is using vertical thermostat type.
4. Cabinet shown is Style 3, risers back right.
5. Supply air K.O.'s have to be field removed.
6. Supply air angles are shipped loose. Break off for 6" or 8". Position inside and attach with screws.
7. Service clearances: Front requires 24" from finished wall plus 4" added to cabinet width.

HRCX SERIES

COMMERCIAL WATER SOURCE HEAT PUMP

PRIMARY/SECONDARY CABINET INSTALLATION

TOP VIEW

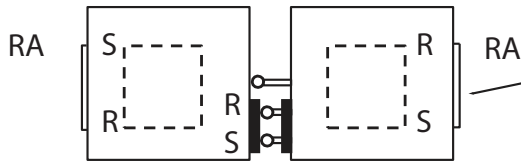

Field connect hoses in both cabinets supply to supply and return to return (Cabinet supply is closest to corner, chassis supply is on left facing air coil)

SIDE VIEW

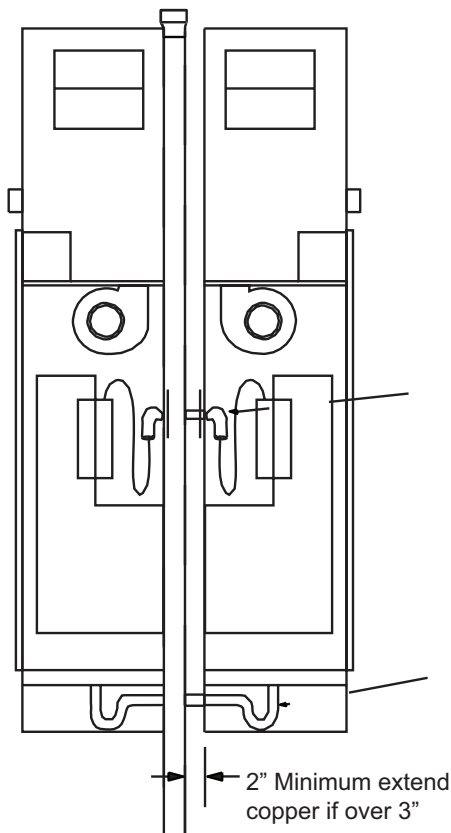

Field braze valve package (shut off with tubing)

Field install P-Trap and Clamp both ends

2" Minimum extend copper if over 3"

WHEN CABINETS ARE PUSHED UP TO RISERS ALLOW SUFFICIENT CLEARANCE. SHUTOFFS SHOULD BE INSIDE CABINET.

TOP VIEW

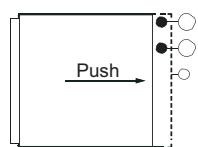

Step 1
Risers Opposite
Return Air Opening

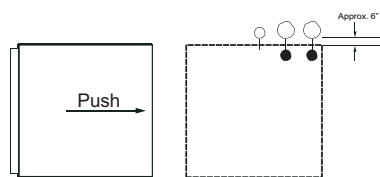

Step 1
Risers Adjacent to
Return Air Opening

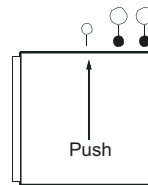

Step 2

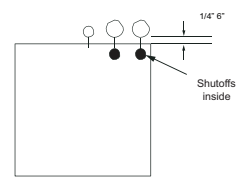

**Final
Cabinet Position**

HRCX SERIES

COMMERCIAL WATER SOURCE HEAT PUMP

VALVE PACKAGES AND ACCESSORIES CABINET FIGURATIONS – AIR FLOW CONFIGURATION

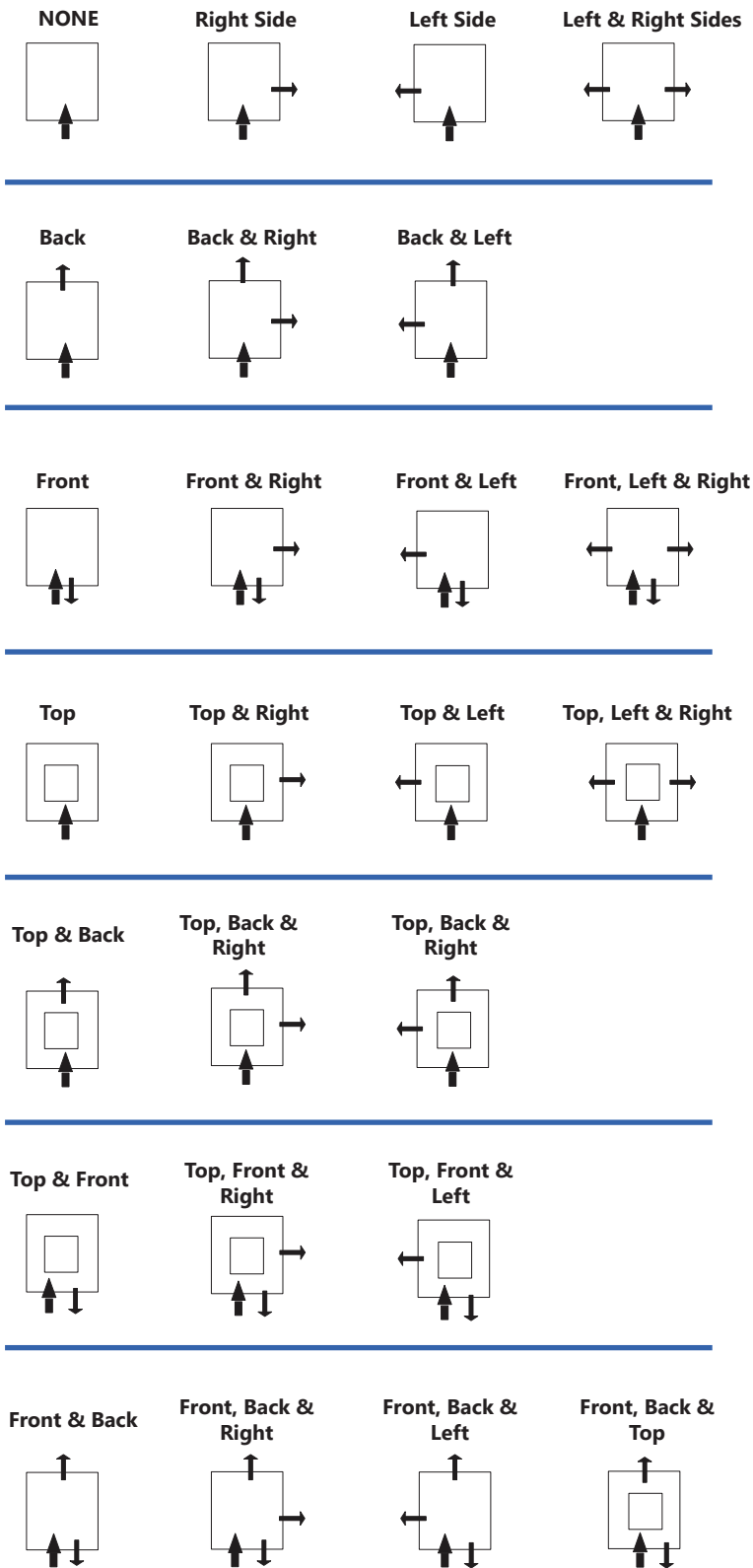

↑ = RETURN AIR (AIR ENTERING CABINET)

↑ = SUPPLY AIR (AIR LEAVING CABINET)

NOTES:

1. Front is return air side and control box location.
2. Risers can be on any side without return or supply air openings.
3. All sides and top have KO's.

HRCX SERIES

COMMERCIAL WATER SOURCE HEAT PUMP

ACCESS RETURN PANEL

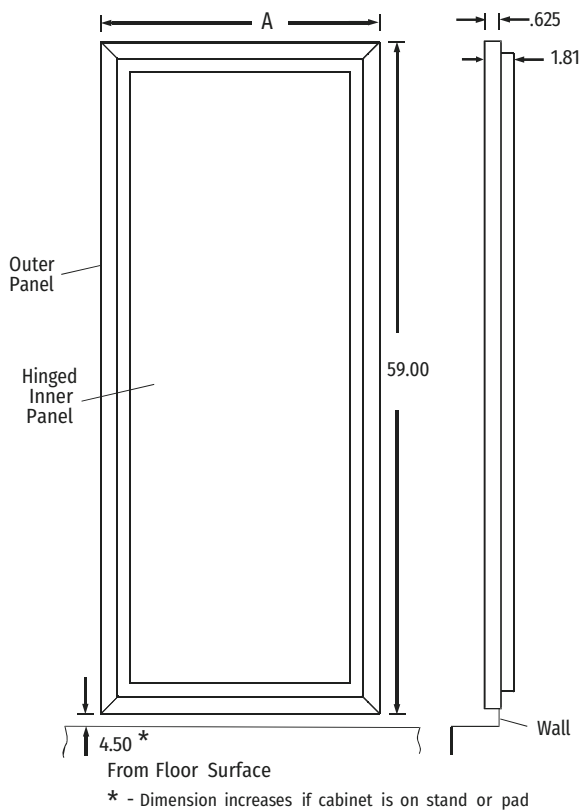
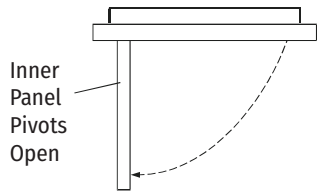

Front View
Standard Panel

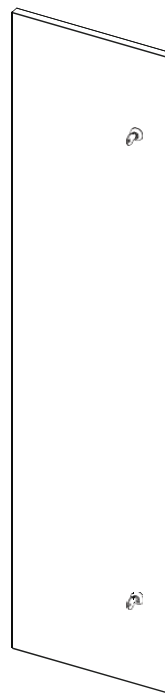

Optional
Inner
solid panel

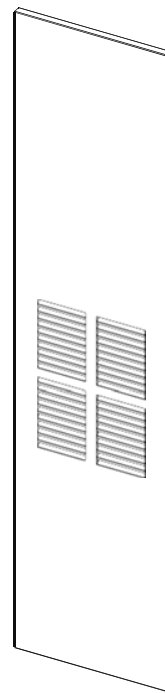

Optional
Inner panel
with Grille
(Stamped Louvers)

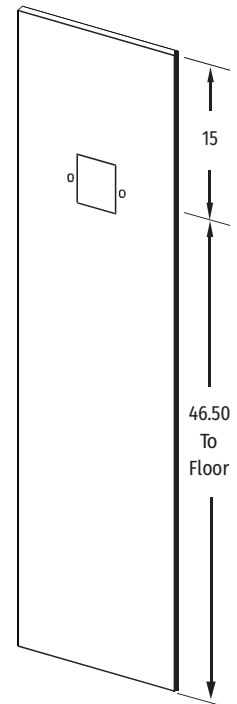

Optional
Inner Panel with
holes to mount
ADA Thermostat

Unit	A
09-18	21.50
24-36	25.50

PANEL PART NUMBERS	
09-18 SIZE	9PWHR01
24-36 SIZE	9PWHR02

NOTES:

1. Dimensions are in inches.
2. Panel powder coated ceiling white.
3. Inner panel pivots open 90°F, for filter replacement without removing panel.
4. Shipped as left-hand pivot.

HRCX SERIES

COMMERCIAL WATER SOURCE HEAT PUMP

CABINET PLATFORMS SPECIFICATIONS

- 12" tall
- 16 Gauge galvanized steel
- Attached to cabinet with 4 screws
- Field installed

Unit	A	B	C
09-18	18.86	18.25	12
24-36	23.86	23.25	

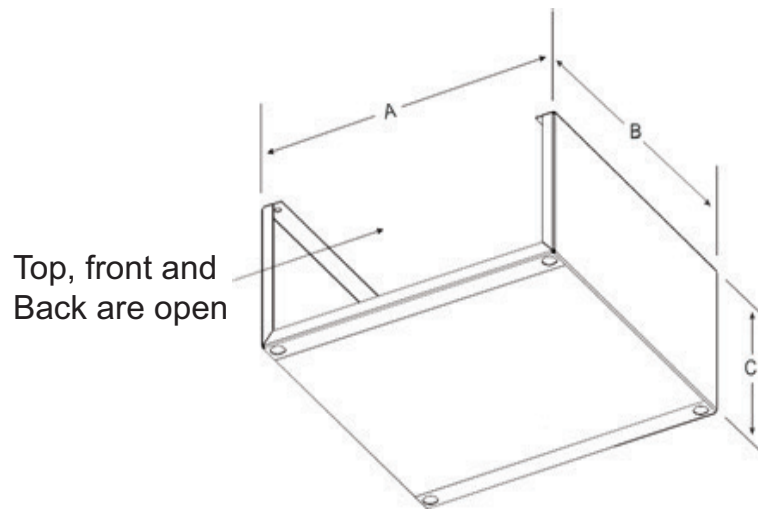

HRCX SERIES

COMMERCIAL WATER SOURCE HEAT PUMP

DISCHARGE AIR OPENINGS

DISCHARGE AIR OPENINGS (ANY COMBINATION, TOP AND SIDES, GRILLES OR DUCTWORK)				
Unit Size	1 Opening	2 Openings	3 Openings	4 or more Openings
9FHR,12FHR	12" x 12"	12" x 6"		
18FHR		12" x 12"	12" x 6"	
24FHR		16" x *	16" x **	
30FHR		16" x *	16" x **	
36FHR		16" x *	16" x **	

NOTES:

1. When selecting supply air openings/grilles consider CFM, velocity (throw), added static pressure and sound.
2. If custom grille sizes are used - area should be greater or equal to above.
3. If using more than recommended number of opening, total CFM may be reduced or be unstable (PSC or ECM Motor).

* - 88" Cabinet = 16"

** - 88" Cabinet = 8"

Standard cabinet openings and grille sizes. (W x H)

88" cabinet models 09-18

front, back, or sides 12 x 12 or 12 x 6 and top 12 x 12.

88" cabinet models 24-36

front, back, or sides 16 x 16 or 16 x 8 and top 16 x 16.

IMPORTANT

Top air discharge units will require turning vanes and/or a volume damper for proper air flow and balancing, to minimize turbulence. These components must be field furnished and installed in accordance with SMACNA guidelines.

HRCX SERIES

COMMERCIAL WATER SOURCE HEAT PUMP

LOUVERS

Louvers are shipped loose for field installation after drywall has been finished.

Louvers are brushed aluminum or painted (White).

Overall dimensions - add 1.25 to nominal dimensions.

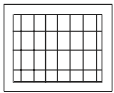

1.88

Single Deflection - Adjustable vertical blades for controlling horizontal path of discharge air (Left/Right).

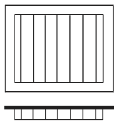

Double Deflection - Adjustable vertical and horizontal blades for controlling horizontal and vertical path of discharge air. (Left/Right and Up/Down) Recommended for all standard applications.

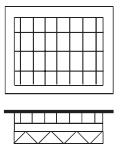

3.25

Double Deflection with Opposed Blade Damper - Addition of opposed blade damper to grille allows control of air volume (CFM) and path of discharge air. Recommended for applications requiring unequal air flow or side discharge grille(s) with additional top discharge air opening.

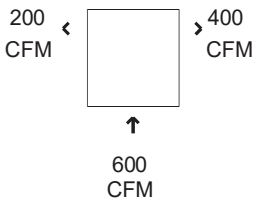

Unequal Air Flow - Air discharges requiring different air volumes (CFM). Use double deflection with opposed blade damper grills.

Nominal Louver Size	Double Deflection Free Area (Sq. Ft)		
	Deflection 0°	Deflection 22 1/2°	Deflection 45°
12 x 6	0.30	0.28	0.22
12 x 12	0.65	0.59	0.48
16 x 8	0.61	0.55	0.44
16 x 12	0.93	0.85	0.68
16 x 16	1.25	1.12	0.90

HRCX SERIES

COMMERCIAL WATER SOURCE HEAT PUMP

SPECIFICATIONS GUIDE

General - Equipment shall be completely assembled, piped, internally wired, fully charged with R-454B refrigerant and test operated at the factory. Filters, thermostat field interface terminal strip, and all safety controls are furnished and factory installed. The equipment shall contain ETL, CETL and ISO –ARI 13256-1 listings and labels prior to leaving the factory.

Cabinet Construction - The structural integrity of the cabinet shall remain unaffected by the removal of any or all access panels. Fabricated from a minimum of 18-gauge galvanized steel. All panels shall be insulated with 3/4" Foil Face fiberglass insulation, meeting the erosion requirements of UL 181 and ASTM E-84 flame spread and smoke development standards. Access for inspection and cleaning of the unit drain pan, coils, and fan section shall be provided.

Cabinet Stand (OPTIONAL) - Heavy gauge galvanized sheet metal stand field-attached to the bottom of the cabinet. Contact the factory for details.

Cabinet Construction for Surface Mounted Thermostat - Cabinet has pre-wired 2 x 4 x 1 7/8 deep electric box mounted for vertical thermostat. Contractor must turn prior to dry walling if field-supplied horizontal thermostat is used. The wire harness ends with a 9-Pin Molex quick connector for easy connection to factory provided thermostats or can be cut off. See Cabinet decoder.

Discharge arrangements - Field selectable discharge air arrangements with knockout on all 4 sides of unit cabinet.

Filter Section - Includes 1" disposable type fiberglass filters with a premium extruded rubber gasket on panel.

2" Filter (OPTIONAL) - Improves air filtration and reduces maintenance.

Accessory Filters (Availability Based on Application):

- 1" thick, MERV 8, and MERV 11
- 2" thick, MERV 8, MERV 11, MERV 13

Drain Pans - The condensate pan is constructed of corrosion-resistant material, sloped to ensure proper drainage. Each drain pan includes an electronic condensate overflow switch. The pan shall meet UL 945V-B flame rating requirements.

Sound Attenuation (OPTIONAL) - A heavy-duty, insulated compressor cover is available to reduce unwanted compressor noise. This option must be field installed before the unit is installed.

Blower Assembly - Double-width, double-inlet (DWDI) forward curved, centrifugal type wheels are statically and dynamically balanced for smooth, quiet operation. Housings are constructed of heavy gauge steel with die-formed inlet cones.

Motors - Fan motors are 3-speed, 208/230V and 265V options, single phase, 60-Hz electronically commutated motor type, factory mounted on the blower housing. Three motor leads connect directly to the control board. Gray is a 50% speed used when only "fan" is selected. Violet and White are the ramp up speeds used when in normal heating or cooling modes. See wiring diagram for proper speed tap selection.

Heat Exchanger - Features a tube-in-tube coaxial water-to-refrigerant heat exchanger, constructed of convoluted copper (optional Cupro-Nickel) inner tube and steel outer tube. Designed refrigerant working pressure: 450 PSIG (3100 kPa). Designed water-side working pressure: 400 PSIG (2750 kPa).

Compressor - Units contain a high efficiency rotary, scroll compressor. External vibration isolation is provided by rubber mounting devices located underneath the mounting base of the compressor. Internal thermal overload protection is provided. Protection against excessive discharge pressure is provided by means of a high pressure switch. A loss of charge is provided by a low pressure safety switch.

SPECIFICATIONS GUIDE (CONT'D)

Refrigerant Coils - Internally finned, 3/8-inch copper tubes mechanically bonded to a configured aluminum plate fin shall be standard. Fins are manufactured with full depth collars, drawn in the fin stock to provide accurate control of fin spacing and completely cover the copper tubes to lengthen coil life. Coils shall be leak tested at the factory to ensure the pressure integrity. The coil shall be leak tested to 450 psig and operating pressure tested to 650 psig. The tubes are to be completely evacuated of air and correctly charged with proper volume of refrigerant prior to shipment. The refrigerant coil distributor assembly shall be of orifice style with round copper distributor tubes. The tubes shall be sized consistently with the capacity of the coil. Suction header shall be fabricated from rounded copper pipe. A thermostatic expansion valve shall be factory selected and installed for a wide range of control.

Reversing Valve - A system reversing valve (4-way valve) is included with all heating/cooling units. This valve is piped to be energized in the cooling mode to allow the system to provide heat if valve failure were to occur. Once the valve is energized for cooling, it will remain energized until the control system is turned to the OFF position, or a heating cycle is initiated. Units with the cooling only option will not receive a reversing valve.

Electrical Components & Controls - The unit control box shall contain all necessary devices to allow heating and cooling operation to occur from a remote wall thermostat. Unit to include a control module that controls the units operation and monitors the safety controls that protect the compressor, heat exchanger, wiring and other components from damage caused by operating outside of design conditions.

- **24V Status LED:** Green light indicates 24V power to the control module.
- **50 VA Transformer:** Assists in accommodating accessory loads.
- **Anti-short Cycle Timer:** 5 minute anti-short cycle protection for the compressor.
 - NOTE: THE 5 MINUTE ANTI-SHORT CYCLE ALSO OCCURS AT POWER UP.
- **Alarm Relay:** The module has a set of contacts for remote fault indication. Contacts can be 24VAC output or converted to a dry contact.
- **Condensate Overflow Lockout:** An electronic sensor deactivates the unit if liquid reaches an unacceptable level.
- **Random Restart Timer:** Minimizes peak electrical demand during simultaneous startups.
- **Nuisance Trip Protection:** The unit attempts startup three times before locking out.
- **Digital Control Module (DCM):** Monitors safety controls and unit operation.
- **Field Selectable Settings:**
 - 5-second compressor delay
 - 45-second blower-off delay
 - Continuous dehumidification mode
- **Test Mode:** Speeds up all time delays for diagnostic purposes.
- **High Pressure Switch:** Located on the discharge line of the refrigeration circuit.
- **Low Pressure Switch:** Located on the suction line of the refrigeration circuit.
- **Low Temperature Cutout Sensor:** Located on the heat exchanger to prevent unit operation below low temperature setting.
- **Over / Under Voltage Shutdown:** Should an Over / Under Voltage condition be detected, the module will initiate a shutdown. Over / Under Voltage Shutdown is a in that if the voltage comes back with range of 18.5VAC to 31VAC, then normal operation will be restored.
- **Vacated Premises Control (VPC) (OPTION):** The vacated premises operation is designed for extended periods of non-occupancy when the occupant desires the heat pump to operate in the cooling mode for a predetermined cycle time to help control indoor air conditions.
 - **HOME selection:** if the switch is in the HOME position the heat pump will operate in its normal mode.
 - **AWAY selection:** if the switch is in the AWAY position and the thermostat is set to the "COOL" mode the heat pump will operate in accordance to the thermostat setting.

SPECIFICATIONS GUIDE (CONT'D)

- **Thermostat Wiring Harness (WHIP) (OPTION):** Low voltage wire harness 15, 25, or 35 foot ending with 9-Pin Molex quick connector. Exits cabinet on top, left front corner. Thermostat cable is rated CL-2. See Cabinet decoder. Can be encased in BX conduit as special, contact factory.
- **Water Loop Valve Package Components (OPTIONAL)** - Valve packages are configurable with the following components:
- **AWBV - Automatic Water Balancing Valve (OPTIONAL)** - regulates the amount of water into each unit to enable a proper Water System balance. The AWPV is provided from the factory at specific selectable flow rates and automatically controls the water flow to within 10% of the rated value over a 40 to 1 differential pressure, and operating range (2 to 80 PSID). The AWPV has an operating pressure rate of 600 psi with a temperature range of 32 to 225°F, and a pressure differential range of 2 to 80 PSID. The AWPV is manufacture with precision sculptured brass and a polyphenylsulfone orifice with an elastomeric diaphragm. The valve body shall be construct from hot forged brass UNS C37700 per ASTM B-283 latest revision.
- **ST - Strainer (OPTIONAL)** – The ST valve body is constructed from dezincification resistant brass with a 600 PSI and a max working temperature of 325°F. The ST filter screen is made of a 20-mesh screen constructed of 304 stainless steel and removable via a cap with an FKM sealing O-Ring. The ST cap has a ¼" or ½" FNPT Port to which a blow-down ball valve is attach including a hose bib threaded connection and cap.
- **IBV - Isolation Valves (OPTIONAL)** - Isolation ball valves mounted between the unit and the supply and return lines of the loop to isolate the water flow to the unit in a maintenance or service situation. The IBV are rated to 600 psi non-shock cold working pressure. Full port, two-piece body with blowout-proof stem and PTFE Seats. ASME B16.33: 125 psig (maximum) and operating temperature of -4°F to 194°F.
- **MCV - Motorized Control Valves (OPTIONAL)** – The MCV actuator is easily removed, ON/OFF type, 2-way, normally close with a spring close actuation and actuates with a 24VAC control signal. The MCV valve comes in two options. MCV Option 1 valve body can operate at a maximum operating pressure of 360 psi, a maximum pressure differential of 75 PSI, operating with fluid temperatures between 36°F to 212°F and a max glycol percentage allowable of 60%. MCV Option 2 valve body can operate at a maximum operating pressure of 300 psi, a maximum pressure differential of 125 PSI, operating with fluid temperatures between 20°F to 220°F and a max glycol percentage allowable of 50%.
- **Flexible Hoses [Standard] (FH):** enable the Supply and Return water connections between the Unit and the water Loop Risers. The two stainless steel FH are made of a stainless-steel outer braid with an inner core of tube made of a nontoxic synthetic polymer material. Fire rated materials per ASTM E84-00 (NFPA 255, ANSI/UL 723 & UBC 8-1). The FH terminations are swivel MPT (Male Pipe Thread) fitting at one end and at the opposite end with a MPT connector sealed with a fiber or EPDM washer, shipped inside the connection. Swivel connection provides union between chassis and risers. The FH have a max working pressure of 400 PSI, temperature-operating range of 15°F to 180°F however, operation below 32°F requires antifreeze.

HRCX SERIES

COMMERCIAL WATER SOURCE HEAT PUMP

PACKAGING AND SHIPPING OPTIONS

UNITS ARE SHIPPED FOB FACTORY

Chassis can be shipped 2 ways.

Vertical or Horizontal configuration.

1. Vertical/Upright in carton 4 per pallet, see **Figure 1**.
2. Vertical/Upright inside cabinet (risers shipped separate or customer supplied) 4 per pallet, see **Figure 1**.
3. Horizontal shipments are on a dedicated open flatbed trailer either 3 or 6 per pallet, see **Figure 2 and 3**.

VERTICAL SHIPPING					
Description	Per 4 pack on pallet			Approx. Quantity Per 53 foot Box Trailer	Approximate Weight per Pallet
	Length	Width	Height		
Chassis 09-18	40	40	50	120 single stacked	500 lbs
Chassis 24-36	50	48	52	96 single stacked	750 lbs
Chassis 09-18	40	40	100	240 single stacked	500 lbs
Chassis 24-36	50	48	104	192 single stacked	750 lbs
Secondary Cabinet 09-18	43	43	85/93	112 single stacked	450 lbs
Secondary Cabinet 24-36	53	53	85/93	72 single stacked	700 lbs
Cabinet with Chassis 09-18	43	43	85/93	112 single stacked	960 lbs
Cabinet with Chassis 24-36	53	53	85/93	72 single stacked	1450 lbs

NOTE:

Shipping Height 93" for 88" cabinet small and large

Cabinets can be mixed on some loads

88" Cabinets cannot have stands factory assembled, must ship loose or units must ship horizontal.

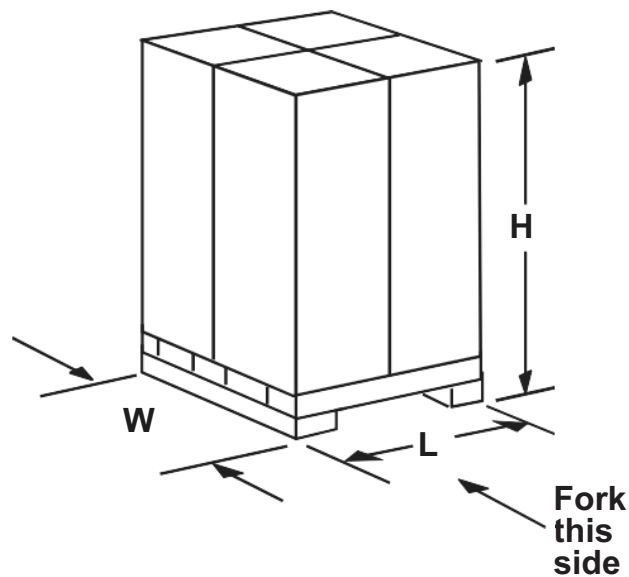

Figure 1
Vertical Configuration

HRCX SERIES

COMMERCIAL WATER SOURCE HEAT PUMP

PACKAGING AND SHIPPING OPTIONS (CONT'D)

UNITS ARE SHIPPED FOB FACTORY

HORIZONTAL SHIPPING							
Description	Number of Cabinets per Pallet	Pallet			Up to 110" Long Riser Approximate Quality per 48 Foot Open Flatbed Trailer	111" to 120" Long Riser Approximate Quality per 48 Foot Open Flatbed Trailer	Approximate Weight per Pallet
		Length	Width	Height			
Cabinet 09-18	4	*	26	88	60	48	800 lbs
	8	*	50	88	60	48	1600 lbs
Cabinet 24-36	3	*	30	87	45	36	800 lbs
	6	*	59	87	45	36	1600 lbs

*- For length of pallet add 5" to riser length

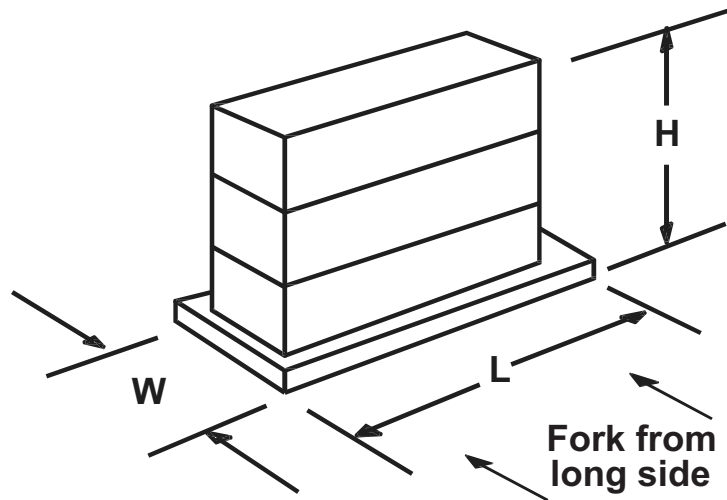

Figure 2
Horizontal Configuration

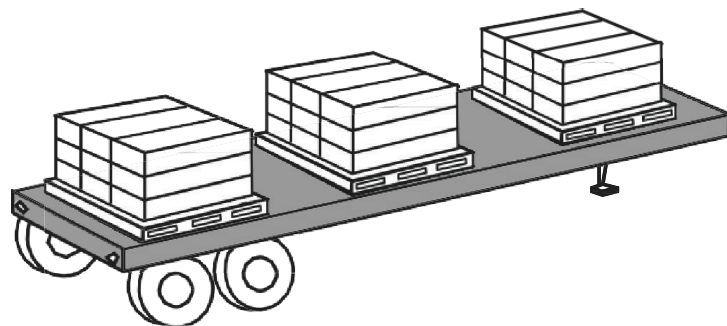

Figure 3
Horizontal Configuration



AMERICAN-MADE. FAMILY OWNED.



FIRST CO.
P.O. BOX 270969 - DALLAS, TEXAS 75227
PH. (214) 388-5751 | FAX (214) 388-2255
WWW.FIRSTCO.COM

MARCH 2025