

# Installation, Operation, & Maintenance

IOM 4403  
Rev. A 12/24

## \*HH(X), \*PHH(X), \*RHH(X), \*CHH(X) HORIZONTAL HYDRONIC FAN COIL UNITS

### ATTENTION:

Read all instructions thoroughly and retain all manuals  
for future reference.



## COPYRIGHT

The Manufacturer works to continually improve its products and as a result, it reserves the right to change design and specifications without notice.



### WARNING/AVERTISSEMENT



These instructions are intended as an aid to qualified, licensed, service personnel for proper installation, adjustment and operation of this unit. Read these instructions thoroughly before attempting installation or operation. Failure to follow these instructions may result in improper installation, adjustment, service or maintenance possibly resulting in fire, electrical shock, property damage, personal injury or death.

# TABLE OF CONTENTS

---

SAFETY CONSIDERATIONS	4
GENERAL	5
INSTALLATION PRECAUTIONS	6
FAN COIL UNIT	7-8
DIMENSIONS	9-12
AIR DISTRIBUTION DUCTS	13
ELECTRICAL	13-14
WIRING DIAGRAMS	15-24
PIPING PRECAUTIONS	25
PRE-STARTUP CHECKS	26
INSTALLATION OF VALVE CLUSTER	27-28
OPERATION & MAINTENANCE	29-33
NOTES	34

## SAFETY CONSIDERATIONS

1. READ THE ENTIRE MANUAL BEFORE STARTING THE INSTALLATION.
2. Improper installation, adjustment, alteration, service, maintenance, or use can cause explosion, fire, electrical shock, or other conditions which may cause personal injury damage.
3. Consult a qualified licensed installer, service agency, or your distributor for information assistance. The qualified licensed installer or service agency must use factory-authorized kits or accessories when servicing this product.
4. Refer to the individual instructions packaged with kits or accessories when installing.
5. Follow all safety codes.
6. Read these instructions thoroughly and follow all warnings or cautions attached to the unit. Consult local building codes and National Electrical Code (NEC) for special requirements.

This appliance is not to be used by persons (including children) with reduced physical, sensory or mental capabilities, or lack of experience and knowledge, unless they have been given supervision or instruction.

Children should be supervised to ensure that they do not play with the appliance

Use adequate personal protection equipment when installing and performing maintenance. After switching off and locking-out an electrical disconnect, verify a safe condition with an electrical tester. Discharge a capacitor before handling any PSC motor and wiring. Use eye protection, cut resistant gloves and sleeves to protect against metal edges and screws.



### RECOGNIZE THE FOLLOWING SAFETY NOTATIONS THROUGHOUT THIS MANUAL AND POSTED ON THE EQUIPMENT:

 **DANGER** 



Indicates an imminently hazardous situation which, if not avoided, will result in death or serious injury

 **IMPORTANT** 

Suggests important procedure steps to insure proper installation, reliability, or operation.

 **WARNING** 

Indicates a potentially hazardous situation or unsafe practices that could result in severe personal injury or death and/or damage to property



 **NOTE** 



Used to highlight suggestions, which may result in enhanced installation, reliability or operation.

 **WARNING** 

 **ELECTRIC SHOCK HAZARD** 

This warning signifies potential electrical shock hazards that could result in personal injury or death.

 **WARNING** 

 **FIRE OR EXPLOSION HAZARD** 

Failure to follow safety warnings exactly could result in property damage, dangerous operation, serious injury, or death. Improper servicing could result in dangerous operation, serious injury, death, or property damage.

- Before servicing, disconnect all electrical power to the unit.
- When servicing controls, label all wires prior to disconnecting. Reconnect wires correctly.

Verify proper operation after servicing

 **CAUTION** 

Indicates a potentially hazardous situation that may result in minor or moderate personal injury

## GENERAL

\*HH Series units are ceiling mounted fan-coil units comprised of a blower assembly and a hydronic coil(s) which can be used with hot or cold water hydronic systems. Electric resistance heaters are available in a variety of kW ratings.

Do not exceed 180° water temperature in the hydronic coil.

**WARNING**

Installation and service must be performed by a licensed professional installer (or equivalent), service agency. Attempting to install or repair this unit without such background may result in product damage, personal injury or death.

Consult local building codes and current editions of the National Electrical Code (NEC) NFPA 70. In Canada, refer to current editions of the Canadian electrical code CSA CEC22.1.

These fan-coils are classified as “Not Accessible to the General Public”.

**WARNING**

This fan-coil must be installed in a location which is not accessible to the general public.

**WARNING**

This appliance is not to be used by persons (including children) with reduced physical, sensory or mental capabilities, or lack of experience and knowledge, unless they have been given supervision or instruction. Children should be supervised to ensure that they do not play with the appliance. Use adequate personal protection equipment when installing and performing maintenance. After switching off and locking-out an electrical disconnect, verify a safe condition with an electrical tester. Discharge a capacitor before handling any PSC motor and wiring. Use eye protection, cut resistant gloves and sleeves to protect against metal edges and screws.

**WARNING**

**ELECTRIC SHOCK HAZARD**

- Always wear eye protection when working equipment.
- Before servicing unit, always turn off all power to unit. There may be more than one disconnect switch. Electrical shock can cause personal injury or death.
- When fan coil is operating, some components are operating at high speeds. Personal injury can result from touching these items with any object.
- All electrical and service access panels must be secured in their proper place before operating equipment.

Clear surrounding area of all tools, equipment and debris before operating unit.

**CAUTION**

Unit must not be operated in any mode during building construction due to excessive airborne dust and debris. Also, the unit must never run under any circumstances without an air filter in place.

The manufacturer does not warrant equipment subjected to abuse. Metal chips, dust, drywall tape, paint overspray, etc. can void warranties and liability for equipment failure, personal injury, and property damage.

These instructions give information for installation of \*HH fan coil units only. For other related equipment, refer to the manufacturer’s instructions.

Material in this shipment has been inspected at the factory and released to the transportation agency in good condition. When received, a visual inspection of all cartons should be made immediately. Any evidence of rough handling or apparent damage should be noted on the delivery receipt and the material inspected in the presence of the carrier’s representative. If damage is found, a claim should be filed against the carrier immediately.

Extreme caution must be taken that no internal damage will result if screws or holes are drilled into the cabinet

## INSTALLATION PRECAUTIONS

### **WARNING**

Use two or more people when moving and installing these units. Failure to do so could result in personal injury or death. Contact with metal edges and corners while applying excessive force can result in personal injury. Use gloves when handling equipment. Use caution during installation or while servicing equipment.

### **WARNING**

If hot water coil is connected to domestic potable water a hot water mixing valve can be applied to the system to temper domestic water draw.

### **WARNING**

Do not exceed 400 psig (27.6bar) pressure in the water coil

Installation of this fan coil should be performed only by a licensed contractor to ensure proper installation and the safety of the installer. Observe the following precautions for typical installations.

- Always use proper tools and equipment.
- No wiring or other work should be attempted without first ensuring fan coil is completely disconnected from the power source locked out. Always verify that a good permanent, uninterrupted ground connection exists prior to energizing any power sources.
- Always review the nameplate and wiring diagram on each unit for proper voltage and control configurations. This information is determined from the components and wiring of the unit and may vary from unit to unit.
- When soldering or brazing to the unit, it is recommended to have a fire extinguisher readily available. When soldering close to water valves or other components, heat shields or wet rags are required to prevent damage.
- When the fan coil unit is in operation components are rotating at high speeds.
- Units must be installed level to ensure proper drainage and operation. These fan coils have a pitched drain pan for improved condensate drainage.

- Check unit prior to operation to ensure that the condensate water will drain toward the drain connection. An overflow drain or an auxiliary drain pan under the fan coil may be required as a back up to a clogged primary drain pan.
- Be sure the drain pan is free from foreign material prior to start up.
- Check the filter media installation to ensure that it is installed correctly. Use the directional arrows or other information on the filter to determine the proper flow direction.
- Ensure air distribution system does not exceed the external static rating of the unit.

### **WARNING**

Do not exceed the maximum operating pressure listed on the unit's rating label.

Insulation is installed in indoor equipment to provide a barrier between outside air conditions surrounding the unit and the varying conditions inside the unit. If the insulating barrier is damaged, the surrounding ambient air will affect the inside surface temperature of the cabinet. The temperature/humidity difference between the inside and outside can cause condensation to form on the inside and outside of the cabinet which leads to sheet metal corrosion and subsequently component failure.

Damaged insulation must be repaired or replaced before the unit is placed back into operation. Insulation loses its insulation value when wet, damaged, separated, or torn.

#### PIPING INSULATION

Installing Contractor - After the system has been proven leak free, all lines and valve control packages must be insulated to prevent condensate drippage or insulated, as specified on the building plans.

NOTE: Many valve packages will not physically allow all components to fit over an auxiliary drain pan. It is the installers responsibility to insulate all piping to ensure adequate condensation prevention.

#### NOISE

These fan coil units are designed for quiet operation; however, all air conditioning equipment will transfer some amount of noise to the conditioned space. This should be taken into consideration when planning the location of the equipment.

# FAN COIL UNIT

This unit may be installed at altitudes up to 10,000 ft. (3,048 m).

The installer must adhere strictly to all local and national code requirements pertaining to the installation of this equipment. These units are designed for installation in a horizontal position.

**NOTE**

Locate the unit in an area that easily provides minimum clearance to all service access panels. Consider all additional clearances needed for water connections, electrical connections, duct connections and sufficient return airflow.

All units are safety agency listed (see unit label) for installation with zero inches clearance to combustible materials. This includes the unit cabinet, discharge plenum and connecting ducts.

The unit is designed for free return installation (non-ducted return air), therefore the furred down area must be completely sealed (except return air louver) to ensure that all return air is pulled from the conditioned space and not from other areas of the building structure.

**WARNING**

When installing \*HH\* unit in close proximity to a room containing a shower, laundry room or other area which is prone to extreme humidity; return air must not be taken from these areas. Do not use a free return when the unit is installed in an extremely humid area of the conditioned space. Seal the return air duct to the unit and locate the return air grille(s) in a common area communicating with the supply-air duct system.

Access must be provided for servicing the unit. If this access is provided by a removable ceiling panel, ample space must be allowed for removal of the blower panel and to provide access to electrical and plumbing controls.

**NOTE**

If a condensate overflow shut off switch, that is designed to be installed in the drain line, is used in place of a secondary drain line then place it in the primary drain line between the fan coil and the P-trap.

### MOUNTING

It is important to ensure that the fan coils are securely mounted and the structure is sufficient to support the weight of the equipment. All anchors for mounting the equipment must be placed and sized to ensure a safe and durable installation.

These units are provided with four (4) mounting slots. Metal washers and nuts of the proper size are to be provided by the installer. When necessary, use shims to obtain the proper level. This will ensure that the condensate will drain from the unit.

Select a location that will provide adequate space to mount the unit and accommodate ducting. The recommended clearance for service is 24" on all sides of the unit. Units may be installed with "0" clearance to combustibles. Always check the unit rating plate for clearance and other information before mounting unit. Refer to dimensional data in FIGURES \_ & \_ for HH\* units and enclosures to determine space required for mounting.

It is important to ensure that the fan coils are securely mounted and the structure is sufficient to support the weight of the equipment. All anchors for mounting the equipment must be placed and sized to ensure a safe and durable installation.

If mounting to wooden joists then use as a minimum 1/4" x 2" wood screws fully engaged with fender washers for securing this unit to the structure.

**WARNING**

When connecting piping to fan coils, do not bend or reposition the coil header tubing for alignment purposes. This could cause a tubing fracture resulting in a leak when pressure is applied to the system.

# FAN COIL UNIT (CONTINUED)

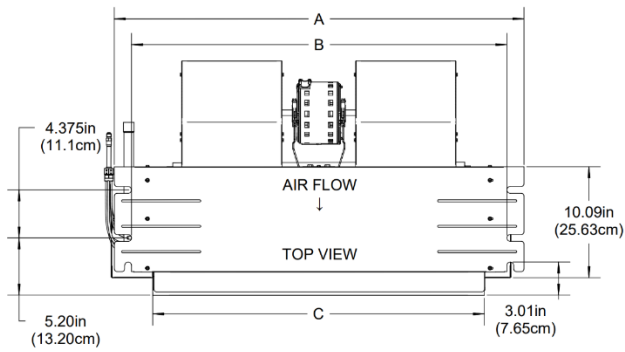

**Figure 1 Top View**

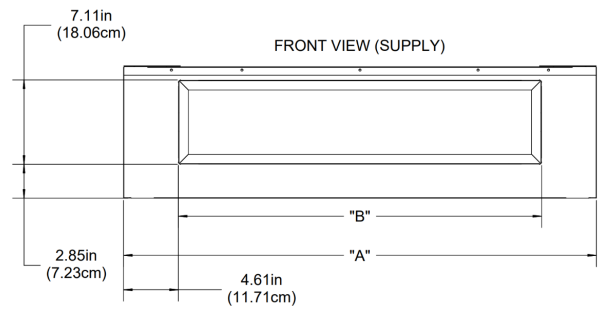

**Figure 4 Front View (Supply)**

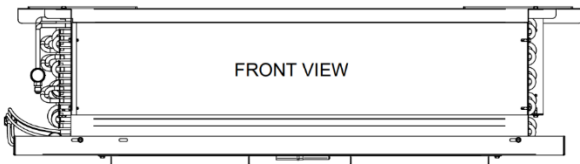

**Figure 2 Front View**

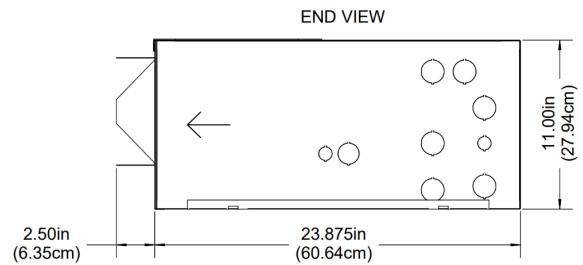

**Figure 5 End View**

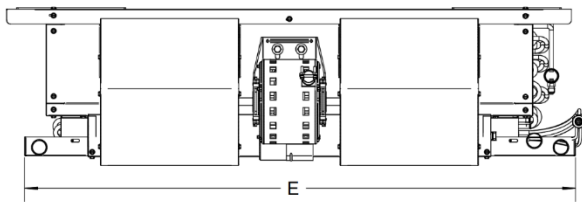

**Figure 3 Side View**

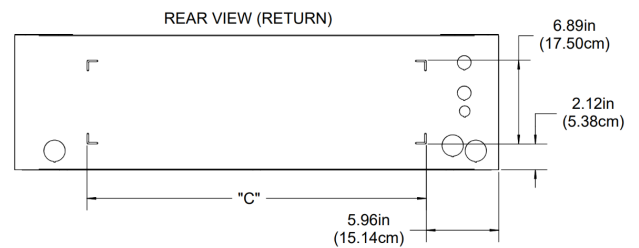
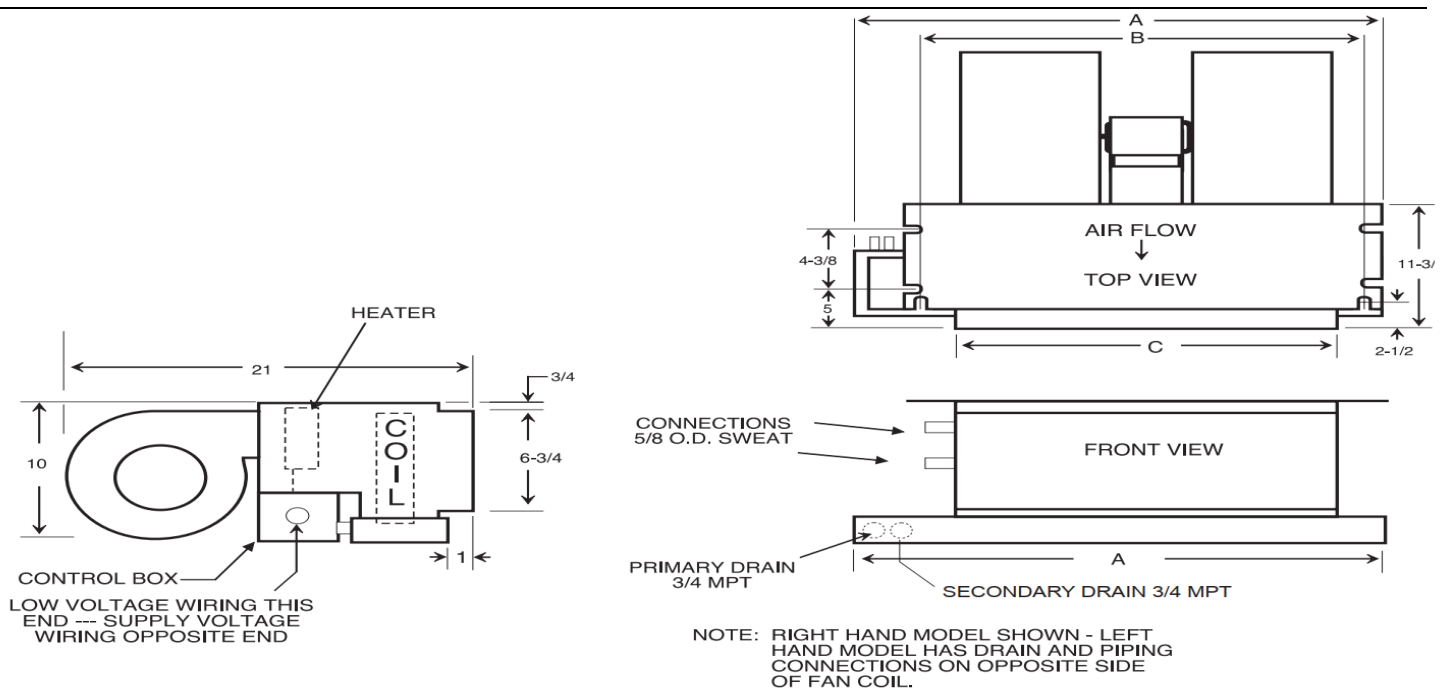

**Figure 6 Rear View (Return)**

## **KNOCKOUT FOR DUCTED RETURN**

(Requires remote filter louver – field supplied)  
 (Ducted return requires non-louvered panel)

# HH SERIES DIMENSIONS



PHYSICAL DIMENSIONS (LESS PLENUM)					
MODEL	A	B	C	NUMBER OF MOTORS	NUMBER OF BLOWERS
3HHS	25	19-11/16	15	1	1
4HHS(X) 6HHS(X) 6HH(X) 8HH(X)	40	34-11/16	30	1	2
10HH(X)	46	40-11/16	36	1	2
12HH(X)	52	46-11/16	42	1	2

**Figure 7 Uncased Version**

# PHH SERIES DIMENSIONS

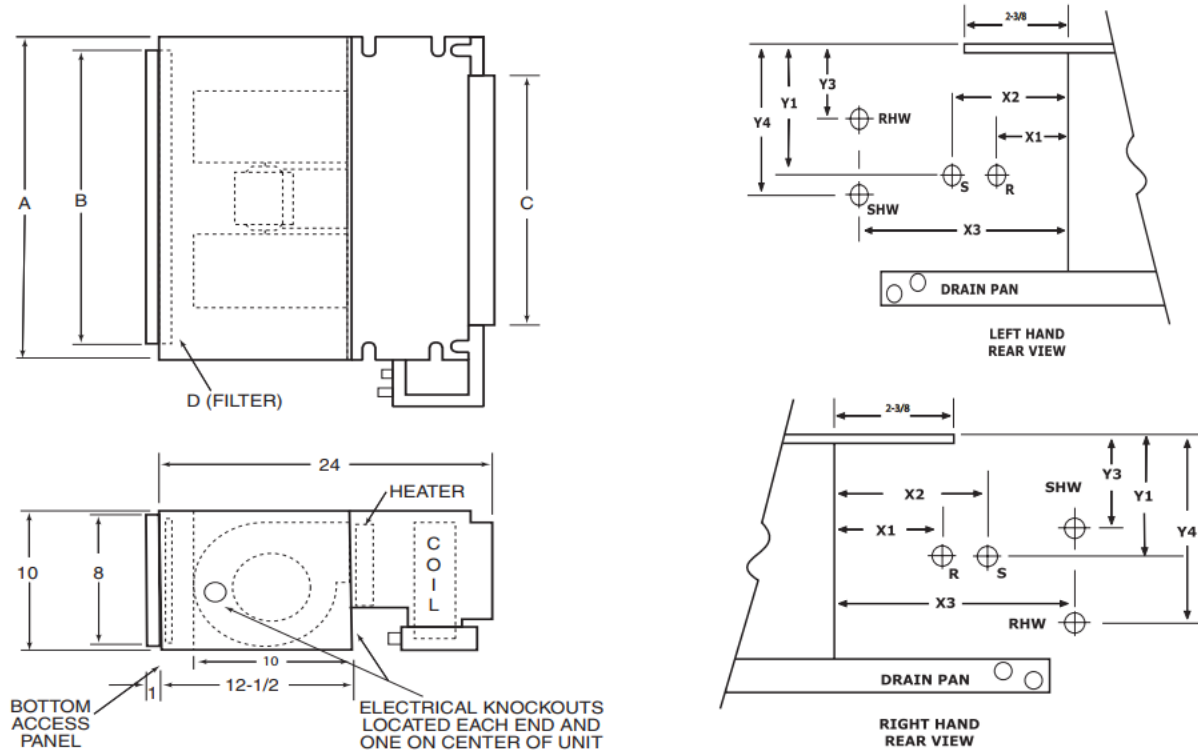

PLENUM DATA				
MODEL	A	B	C	D (FILTER)
3PHHS	20	18	15	10 X 20 X 1
4PHHS(X) 6PHHS(X) 6PHH(X) 8PHH(X)	34	32	30	10 X 34 X 1
10PHH(X)	40	38	36	10 X 40 X 1
12PHH(X)	46	44	42	10 X 46 X 1

**NOTE:** 1. Return plenums are insulated  
 2. All plenums include throw away filter

*Figure 8*

# RHH SERIES DIMENSIONS

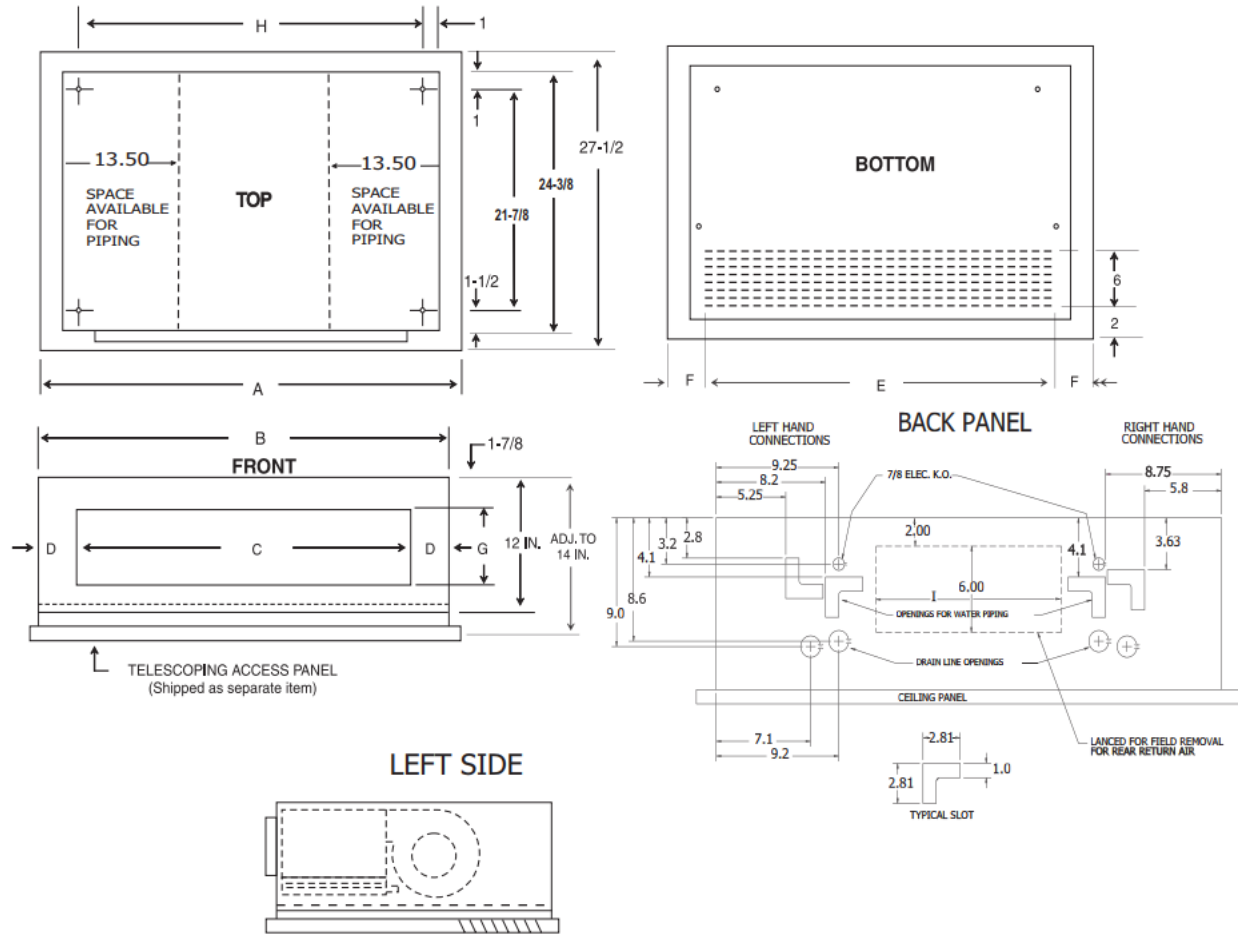

GENERAL DIMENSIONS												
MODEL	A	B	C	D	E	F	G	H	I	TELESCOPING LOUVERED ACCESS PANEL	TELESCOPING SOLID ACCESS PANEL	FILTER SIZE (INCL)
3RHHS	41	38-1/8	29	4-1/2	36-5/8	2-3/16	5-1/2	36	14	968-1	968-1S	10 X 37
4RHHS(X)	51	48-1/8	39	4-1/2	47-1/4	1-7/8	5-1/2	46	24	968-3	968-3S	10 X 47.5
6RHHS(X) 6RHH(X) 8RHH(X)	51	48-1/8	39	4-1/2	47-1/4	1-7/8	5-1/2	46	24	968-3	968-3S	10 X 47.5
10RHH(X)	57	54-1/8	45	4-1/2	52-1/2	2-1/4	5-1/2	52	30	968-4	968-4S	10 X 53
12RHH(X)	63	60-1/8	51	4-1/2	57-7/8	2-9/16	5-1/2	58	36	968-5	968-5S	10 X 59

Figure 9

# CHH SERIES DIMENSIONS

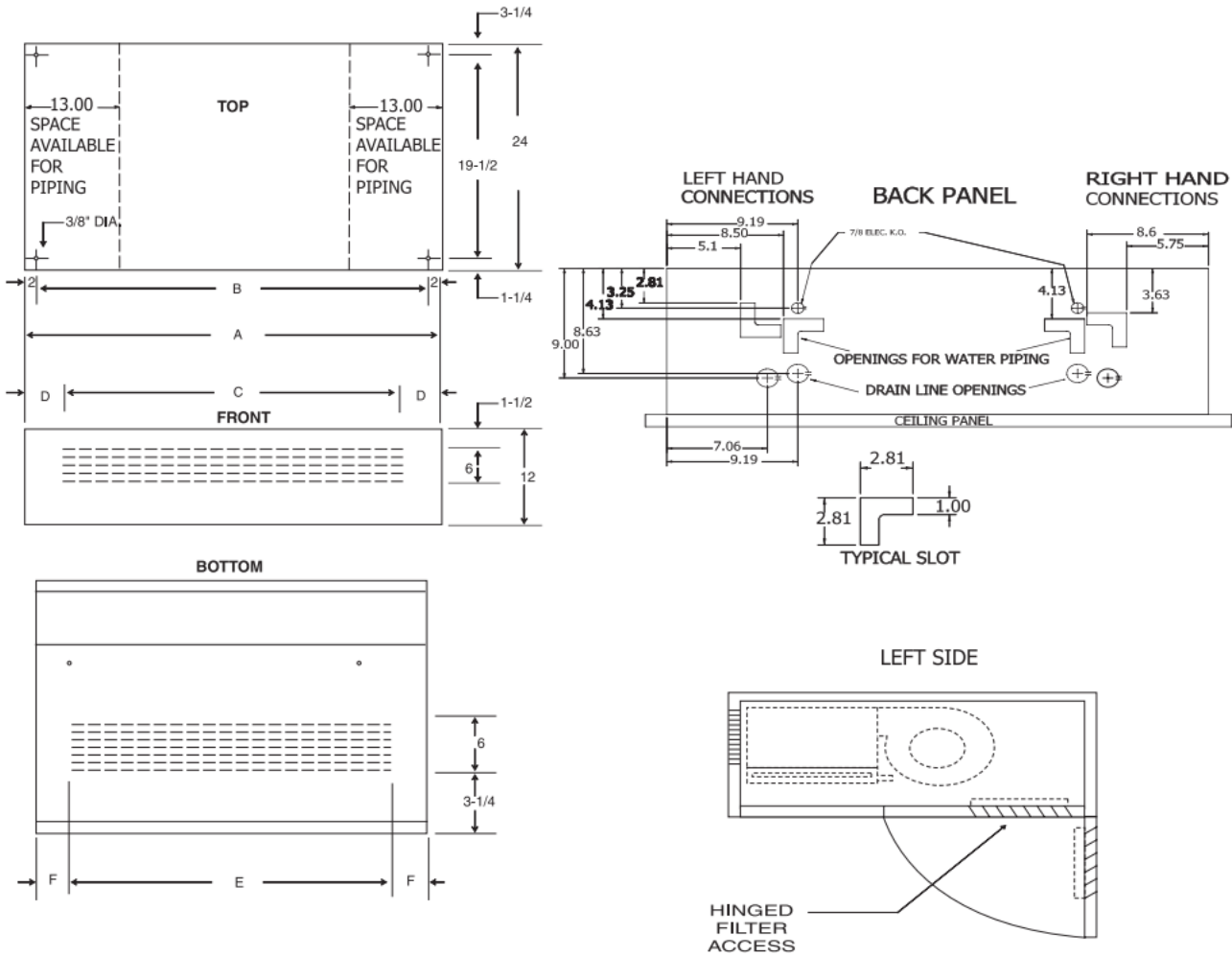

GENERAL DIMENSIONS								
MODEL	A	B	C	D	E	F	FILTER SIZE (INCL)	CONNECTIONS PRIMARY O.D.
3CHHS(X)	33	29	21	6	25-1/2	3-1/2	10 X30	5/8"
4CHHS(X)	48	44	37	5-1/2	41-1/2	3-1/2	10 X 46	
6CHHS(X)	48	44	37	5-1/2	41-1/2	3-1/2	10 X 46	
6CHH(X)	48	44	37	5-1/2	41-1/2	3-1/2	10 X 46	
8CHH(X)	48	44	37	5-1/2	41-1/2	3-1/2	10 X 46	
10CHH(X)	54	50	42-1/2	5-3/4	46-1/2	3-1/2	10 X 53	
12CHH(X)	60	56	48	6	52	4	10 X 59	

Figure 10



## AIR DISTRIBUTION DUCTS

### STATIC PRESSURE

The total external static pressure must be considered when planning installation and duct design. Refer to the rating label on your unit for more information. Units with PSC motors are recommended for use up to .3" total external static pressure. Units with ECM motors are recommended for use up to .5" total external static pressure. A unit operating at lower total external static pressure will be more efficient and quieter vs. operation at higher static pressure.

All duct work must be installed in accordance with National Fire Protection Association Codes 90A and 90B. Supply duct and return system must be adequately sized to meet the system's air requirements and static pressure capabilities. Ducts should be adequately insulated to prevent condensation during the cooling cycle and to minimize heat loss during the heating cycle. The ducts should be insulated with a minimum of 1" insulation with a vapor barrier in conditioned areas.



## ELECTRICAL





	<b>IMPORTANT</b>	
<p>Electrical work associated with the installation of this appliance must comply with the National Electrical Code (NEC). Other local or regional electrical and building code requirements may apply.</p> <p>In Canada electrical work associated with the installation of this appliance must comply with CE CSA C22.</p>		





	<b>WARNING</b>	
<p>USE COPPER CONDUCTORS ONLY</p>		

Ensure field wiring complies with local and national fire, safety, and electrical codes. Ensure voltage supply is within limits shown on unit rating plate. Contact the local power company for correction of improper voltage. Refer to the unit rating plate for recommended circuit protection device.





The unit cabinet must have an uninterrupted and unbroken ground to minimize personal injury if an electrical fault should occur. Provide ground circuit in accordance with all applicable national and local codes.

	<b>WARNING</b>	
<p>The unit cabinet must have an uninterrupted / unbroken ground to minimize personal injury if an electrical fault should occur.</p> <p>. Failure to do so can cause electrical shock resulting in severe personal injury or death.</p>		

	<b>WARNING</b>	
	<b>ELECTRIC SHOCK HAZARD</b>	
<p>Before servicing equipment, ALWAYS turn off all power to the unit. There may be more than one disconnect switch.</p> <p>Electrical shock can cause injury or death.</p>		

	<b>WARNING</b>	
	<b>ELECTRIC SHOCK HAZARD</b>	
<p>Transformers are multi voltage, it is crucial to refer to unit wiring diagram, transformers wiring diagram as well as unit voltage to ensure proper connections and operation safety.</p>		

## ELECTRICAL (CONTINUED)

	<b>WARNING</b>	
	<b>ELECTRIC SHOCK HAZARD</b>	
<ul style="list-style-type: none"> <li>• Disconnect all power supplies before servicing; lock out/tag out to prevent accidental electrical shock. Note: there may be multiple power sources.</li> <li>• Use copper conductors only.</li> <li>• Install all panels before operating.</li> <li>• Failure to follow these warnings can result in injury or death.</li> </ul>		

All wiring must comply with local and national code requirements. Units are provided with wiring diagrams and nameplate data to provide information required for necessary field wiring.

Use 18 AWG wire with color-coded insulation (35°C minimum) up to 100 ft. in length (31 m). Use 16 AWG wire if more than 100 ft. of wire is required.

These units are provided with a Class 2 transformer for 24-volt control circuits. Should any add-on equipment also have a Class 2 transformer furnished, care must be taken to prevent interconnecting outputs of the two transformers by using a thermostat with isolating contacts.

### ELECTRICAL OVER CURRENT PROTECTION

HACR type breakers are recommended. Other over-current protection devices that comply with all applicable codes are acceptable.

	<b>WARNING</b>	
<p>Units with ECM motors have line voltage power applied at all times. Make sure power is disconnected before servicing.</p>		

# WIRING DIAGRAMS

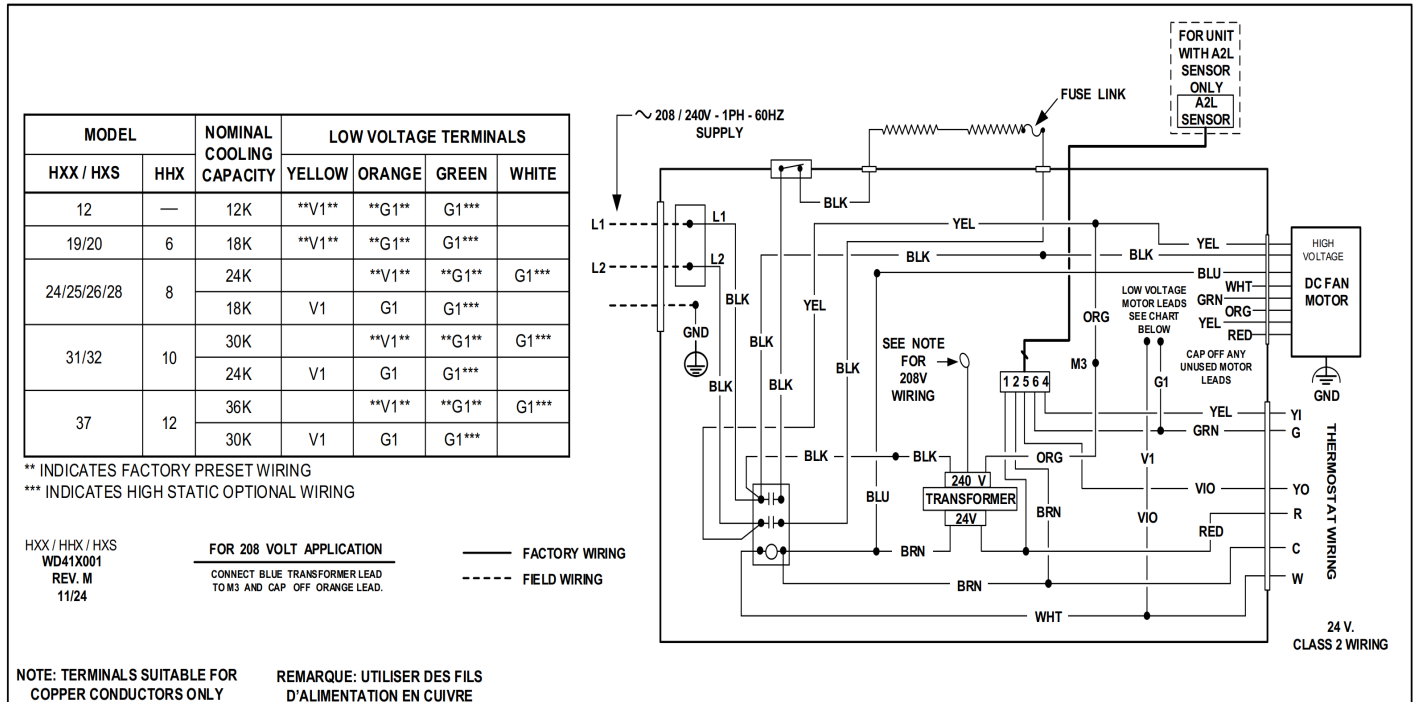

Figure 11 WD41X001

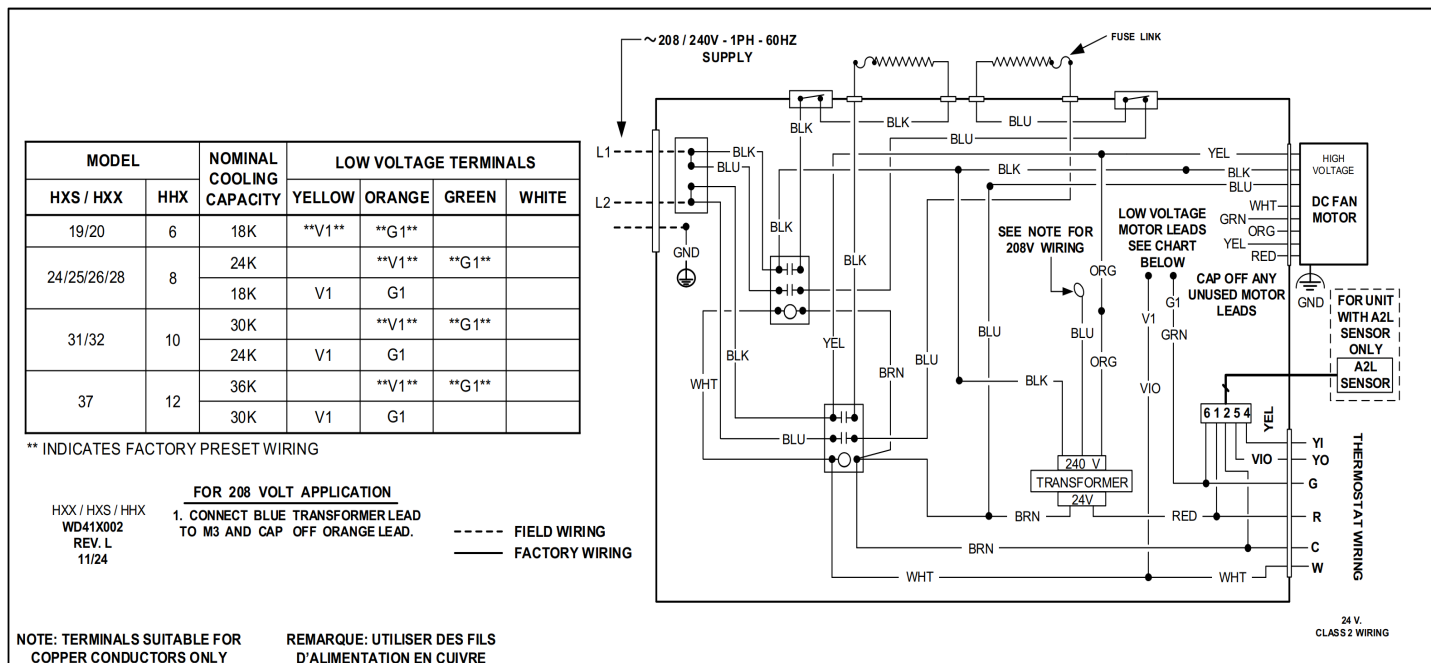

Figure 12 WD41X002

# WIRING DIAGRAMS (CONTINUED)

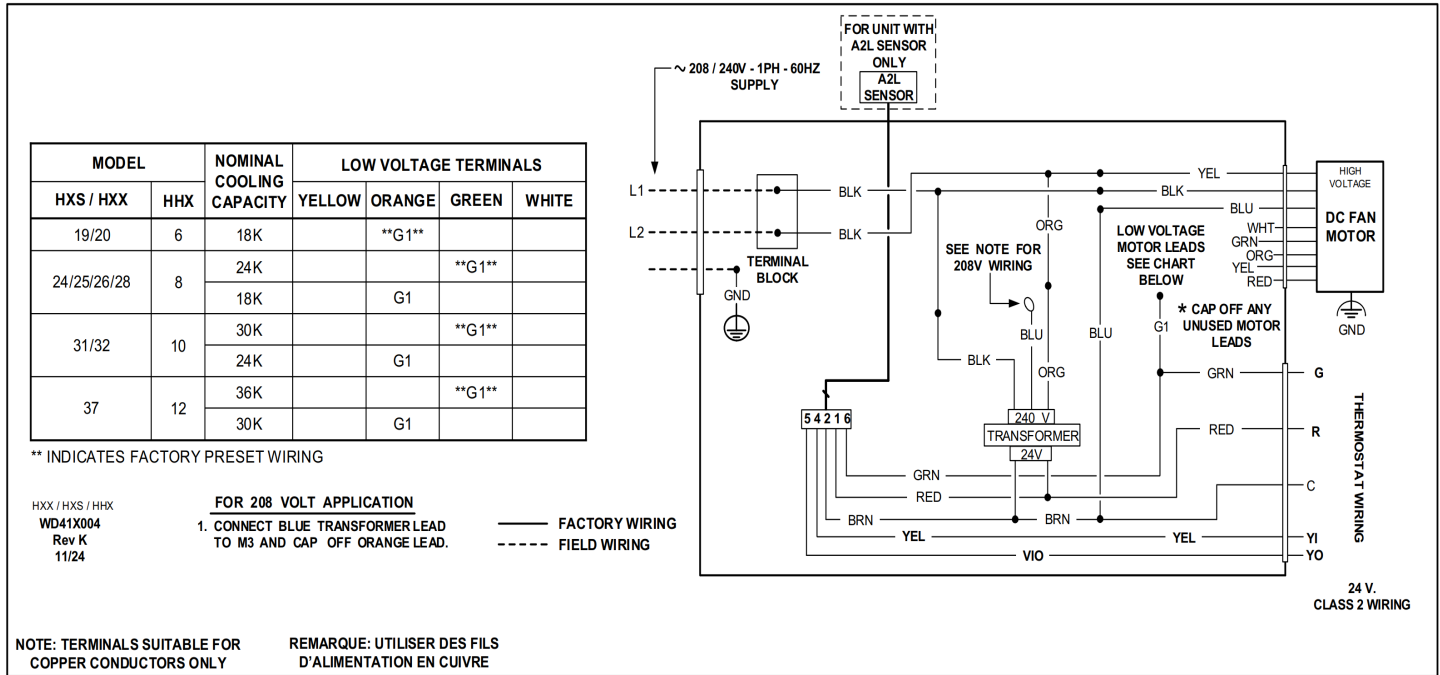

Figure 13 WD41X004

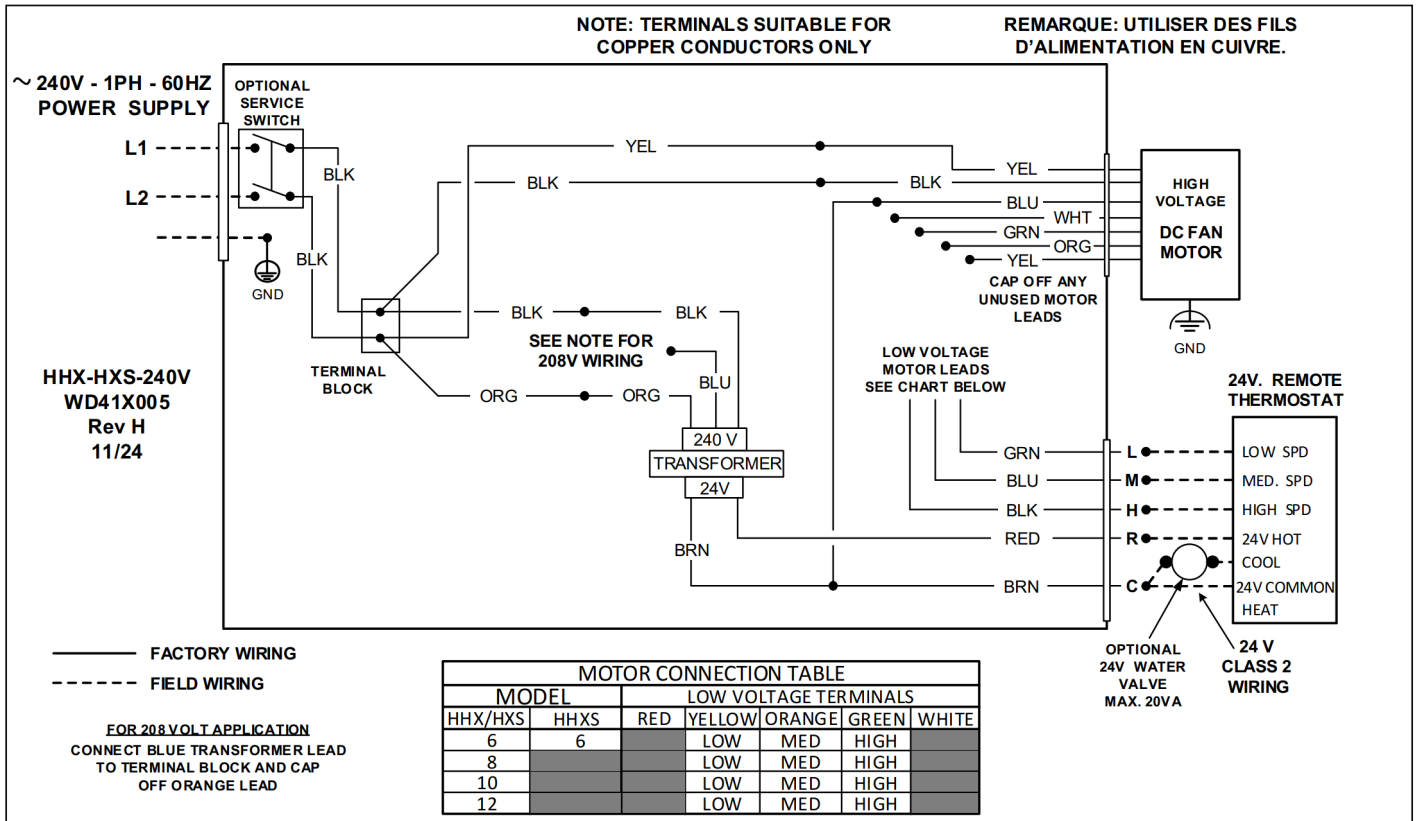

Figure 14 WD41X005

# WIRING DIAGRAMS (CONTINUED)

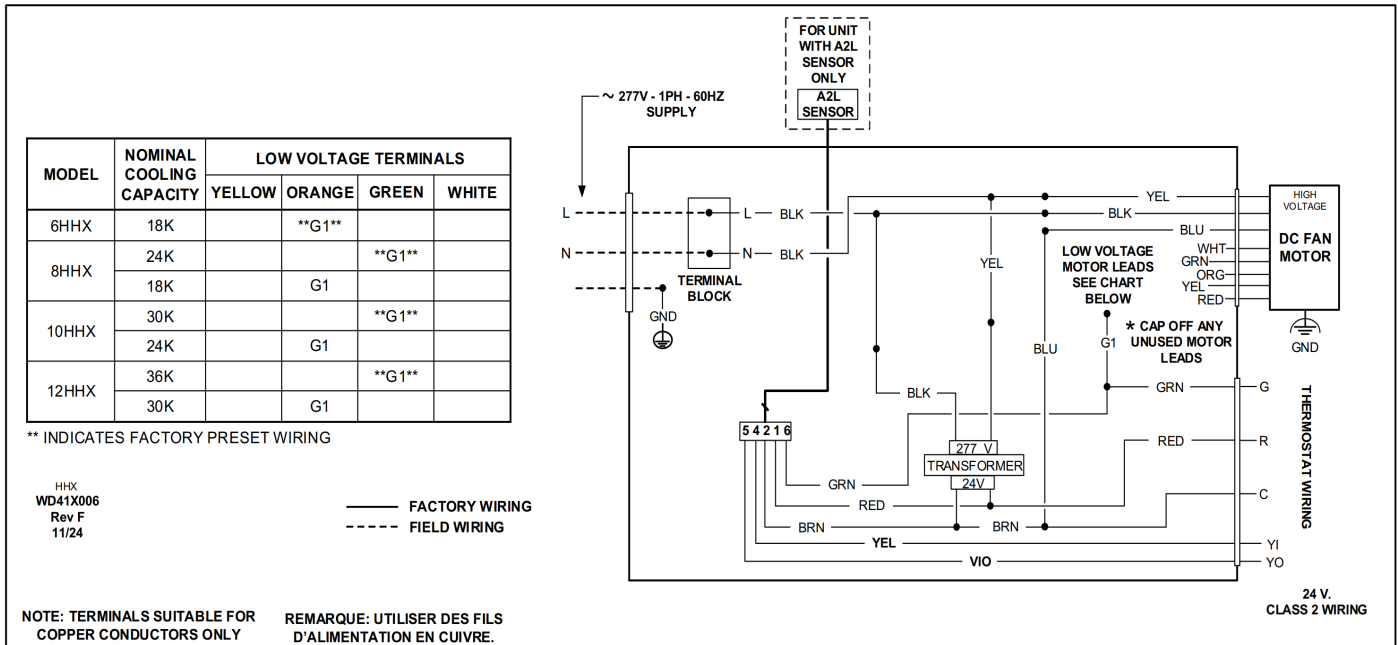

Figure 15 WD41X006

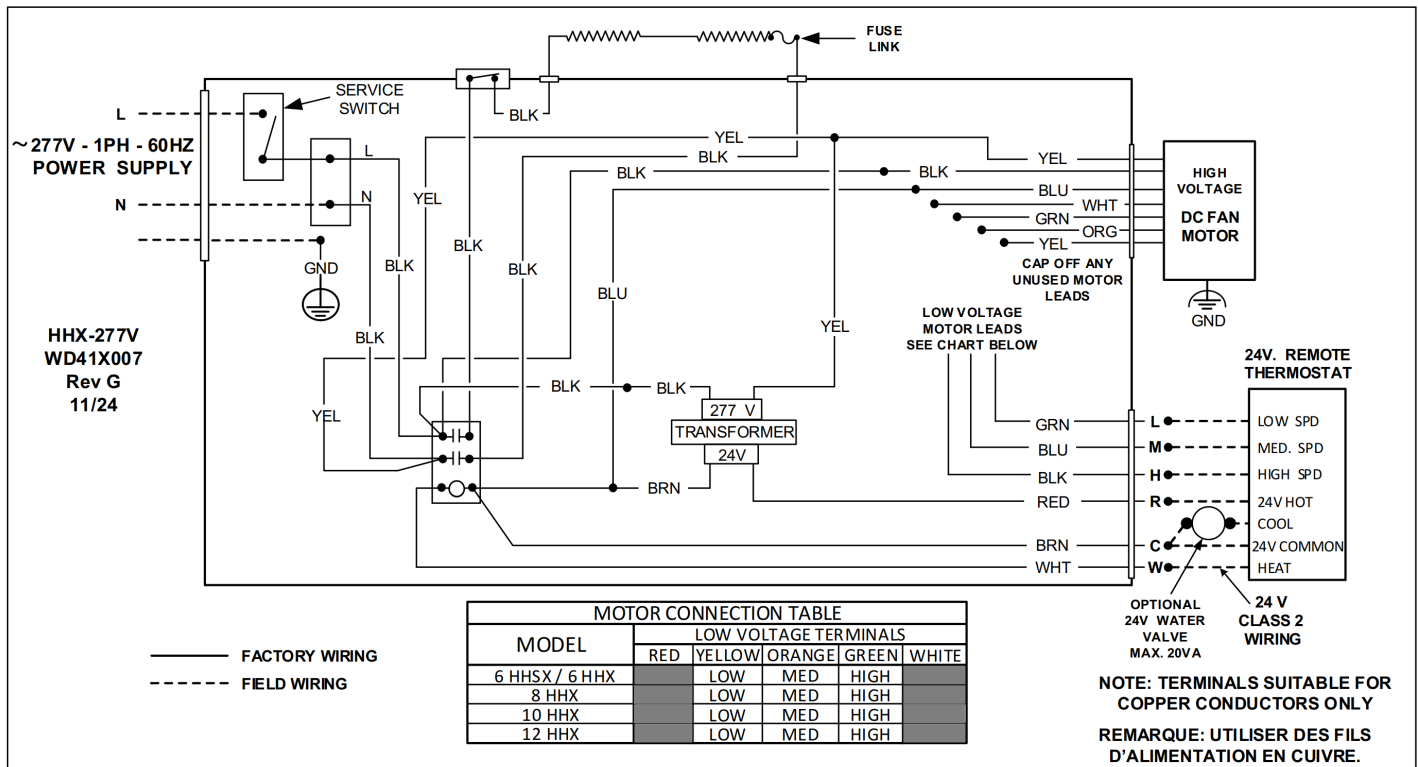

Figure 16 WD41X007

# WIRING DIAGRAMS (CONTINUED)

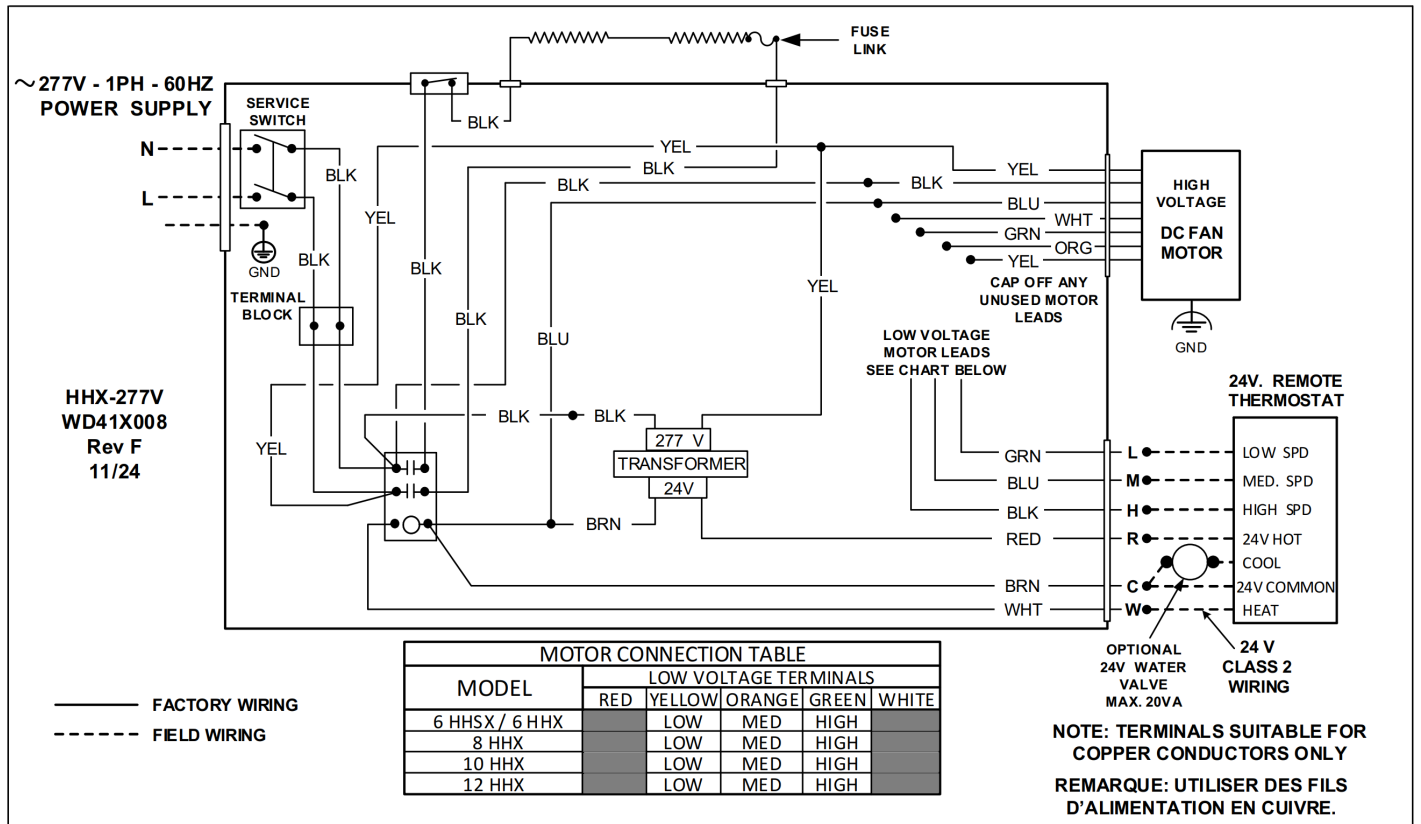

Figure 17 WD41X008

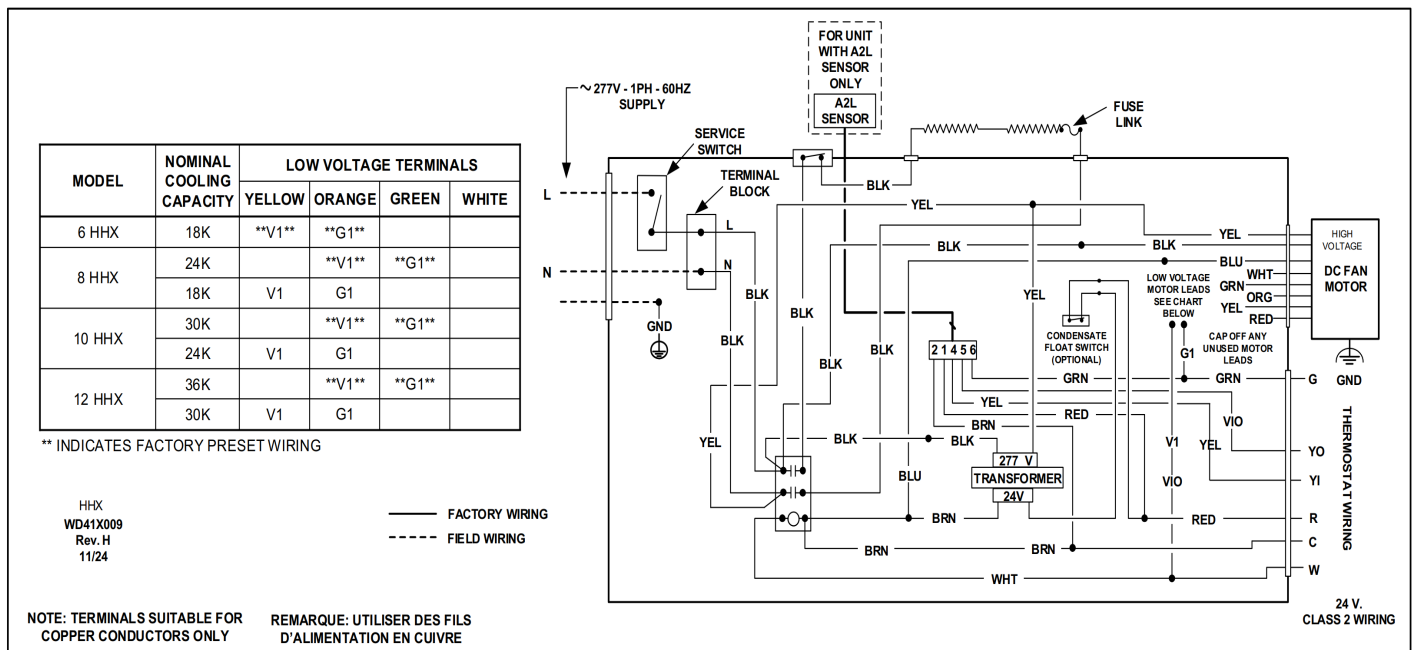

Figure 18 WD41X009

# WIRING DIAGRAMS (CONTINUED)

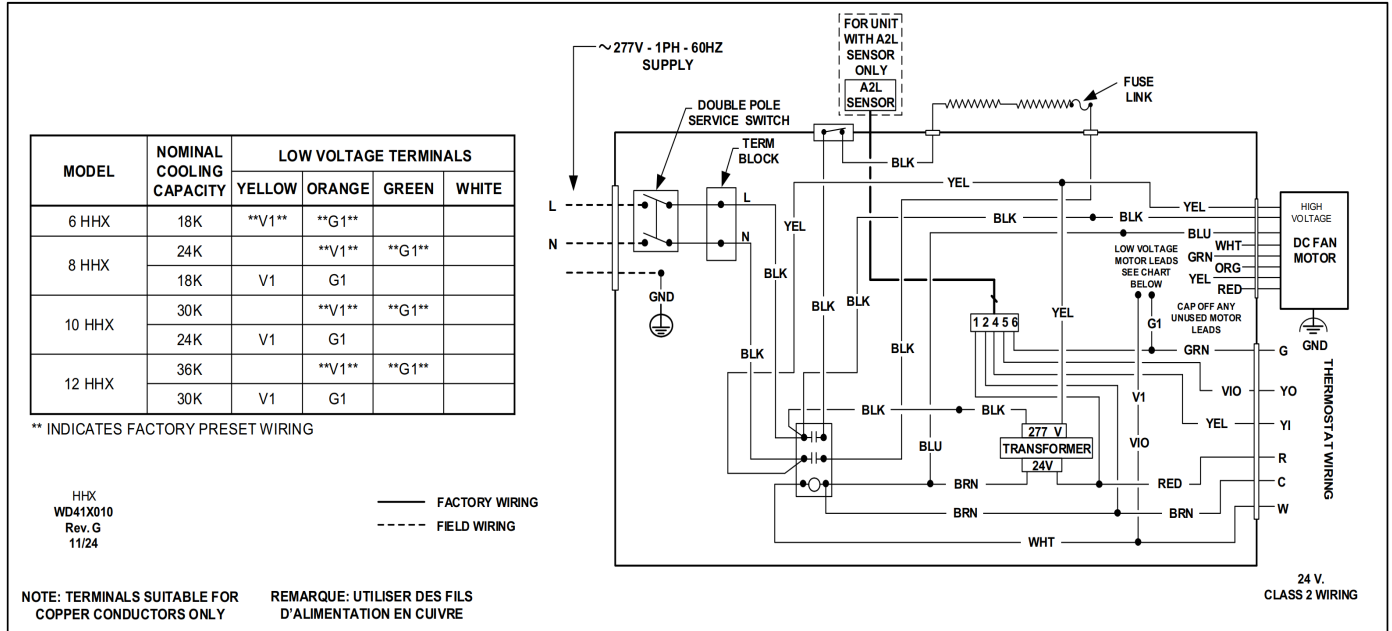

Figure 19 WD41X010

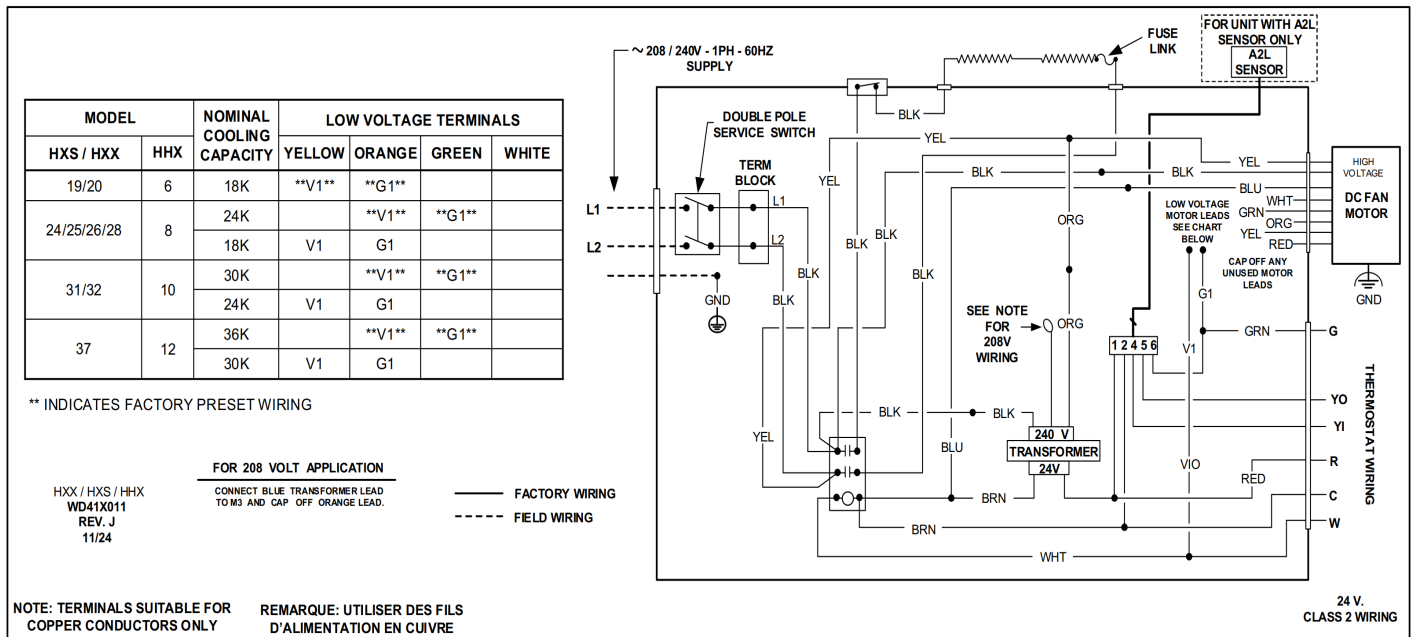

Figure 20 WD41X011

# WIRING DIAGRAMS (CONTINUED)

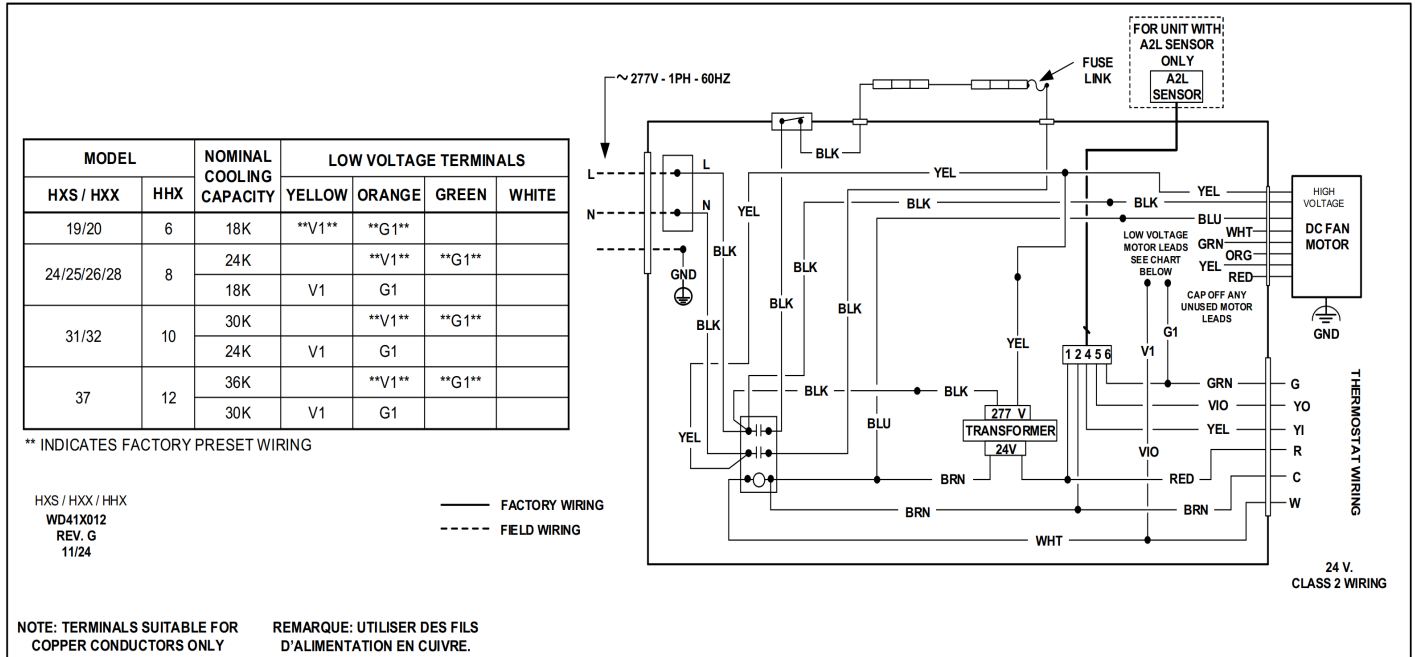

Figure 21 WD41X012

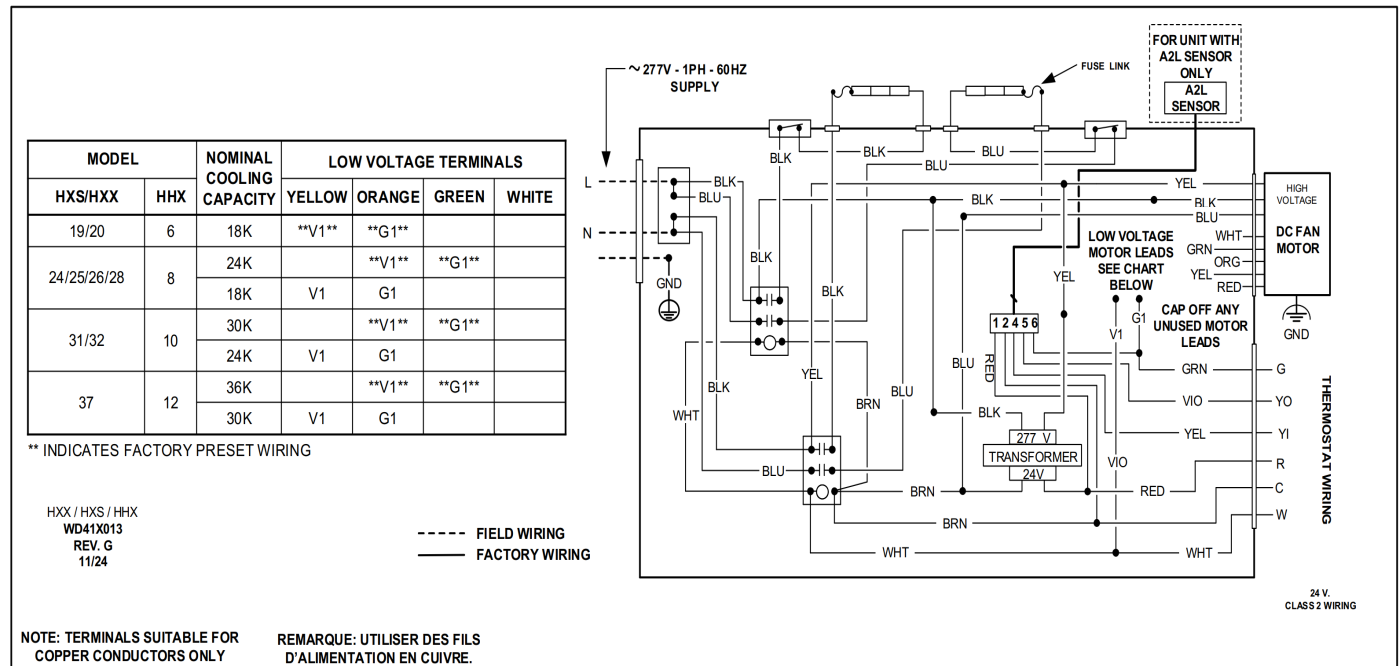

Figure 22 WD41X013

# WIRING DIAGRAMS (CONTINUED)

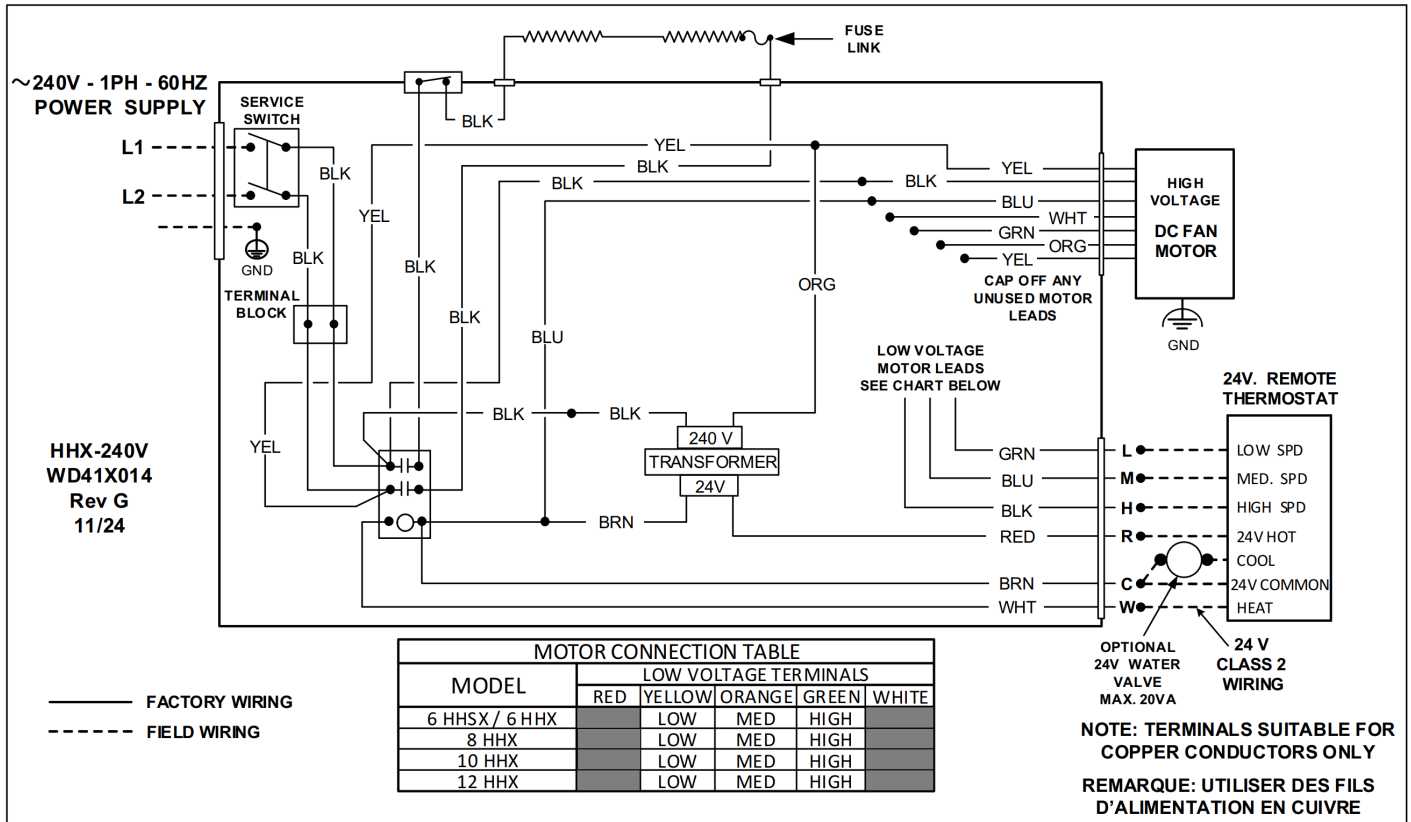

Figure 23 WD41X014

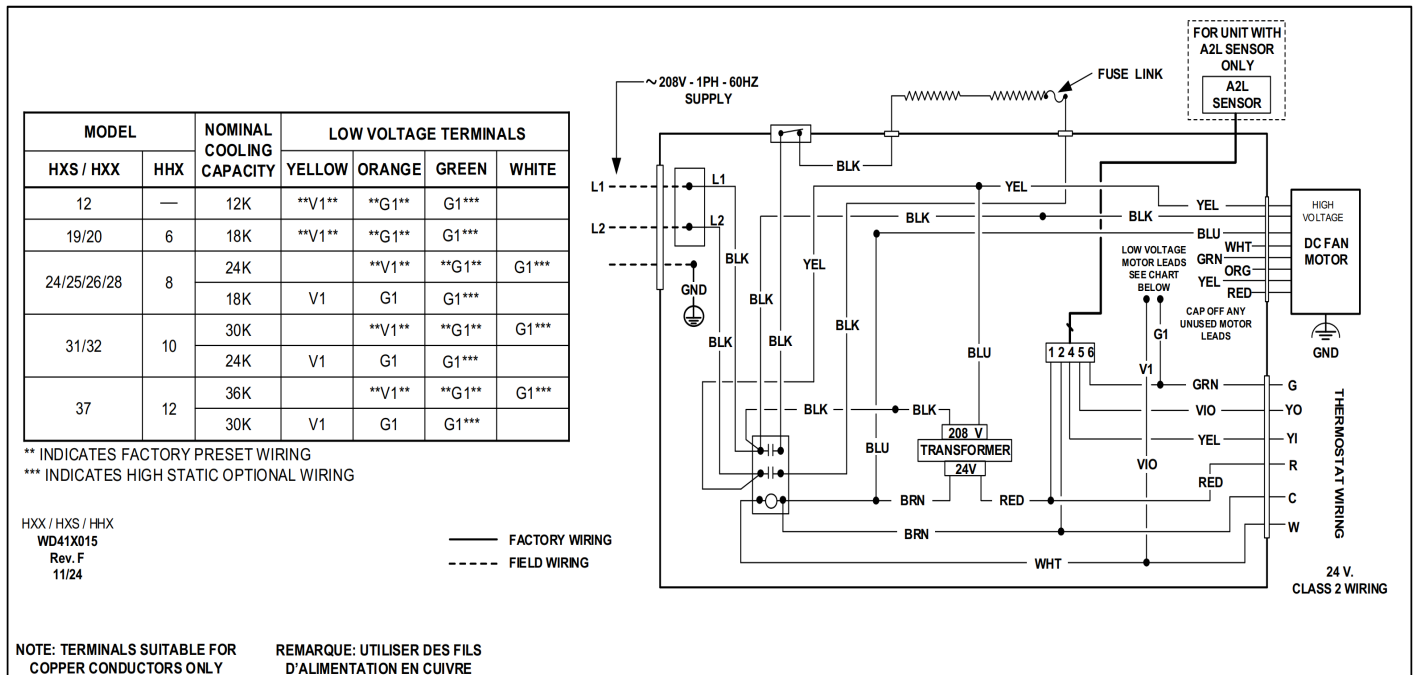

Figure 24 WD41X015

# WIRING DIAGRAMS (CONTINUED)

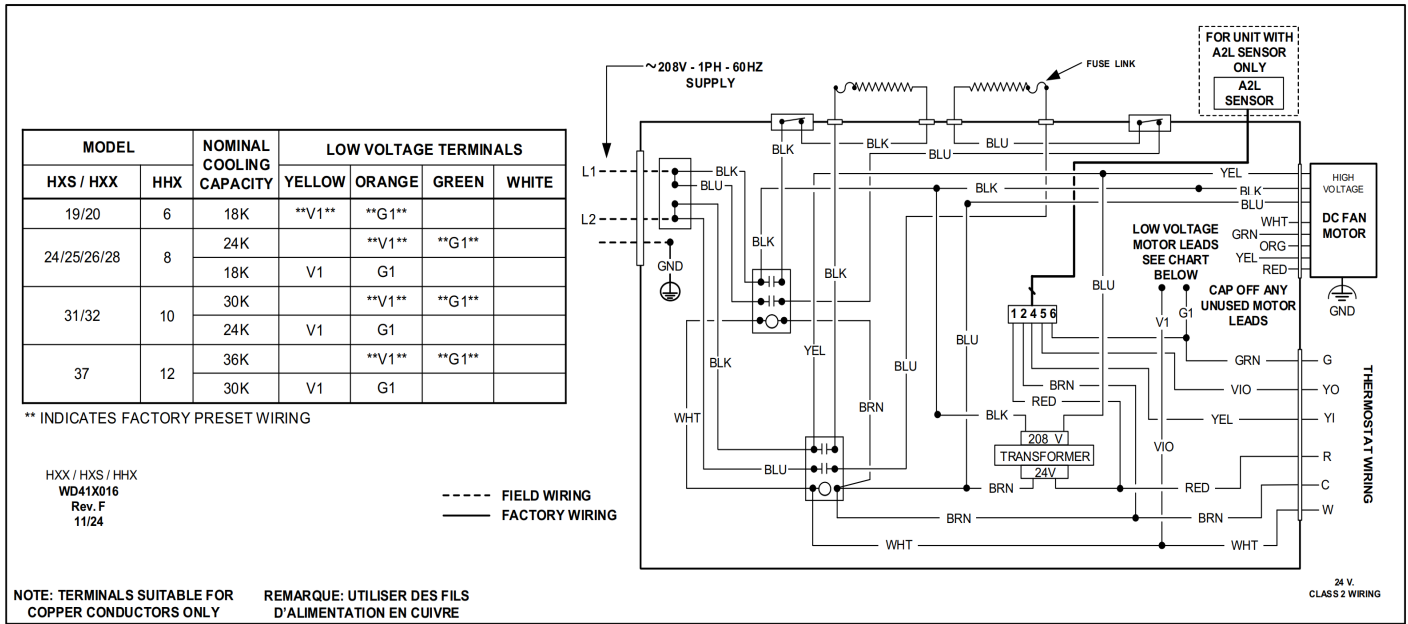

Figure 25 WDX41016

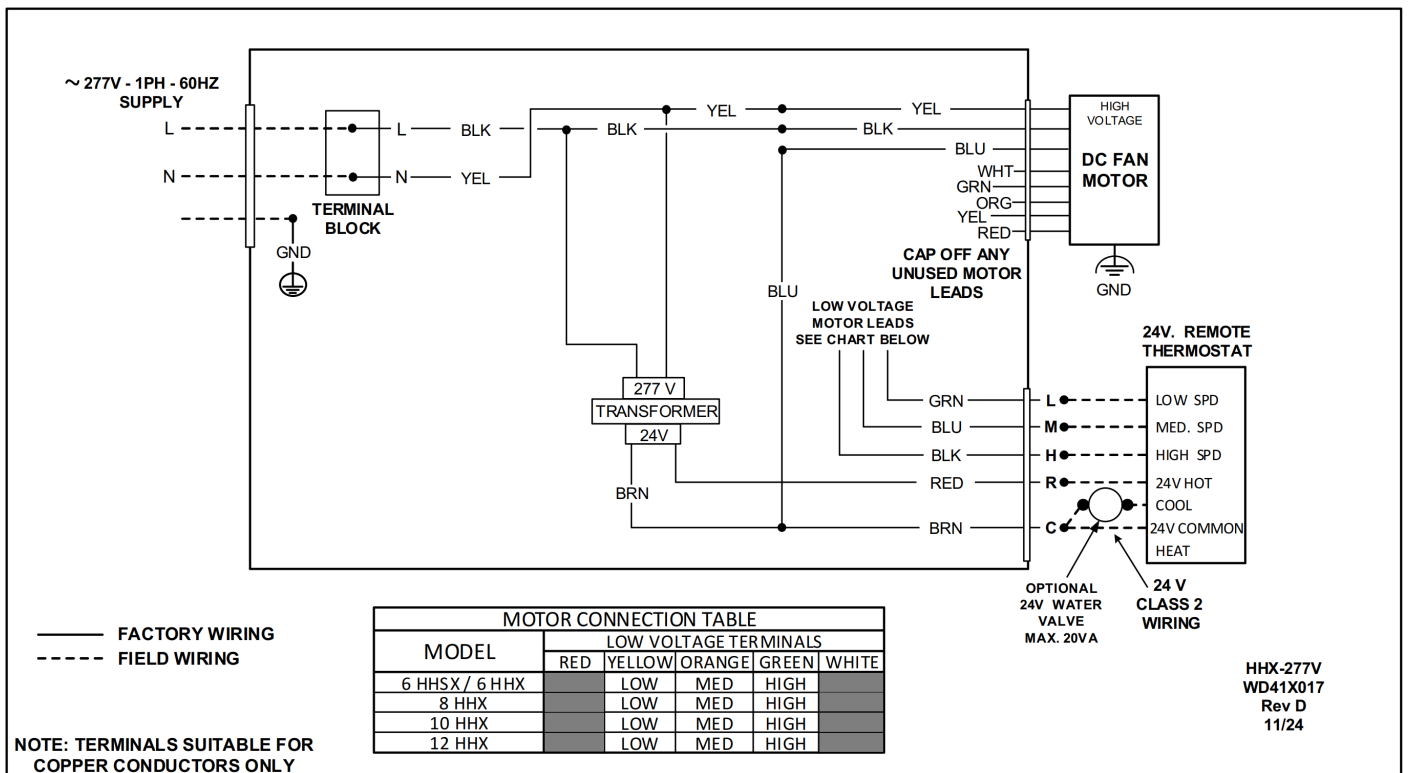

Figure 26 WDX41017

# WIRING DIAGRAMS (CONTINUED)

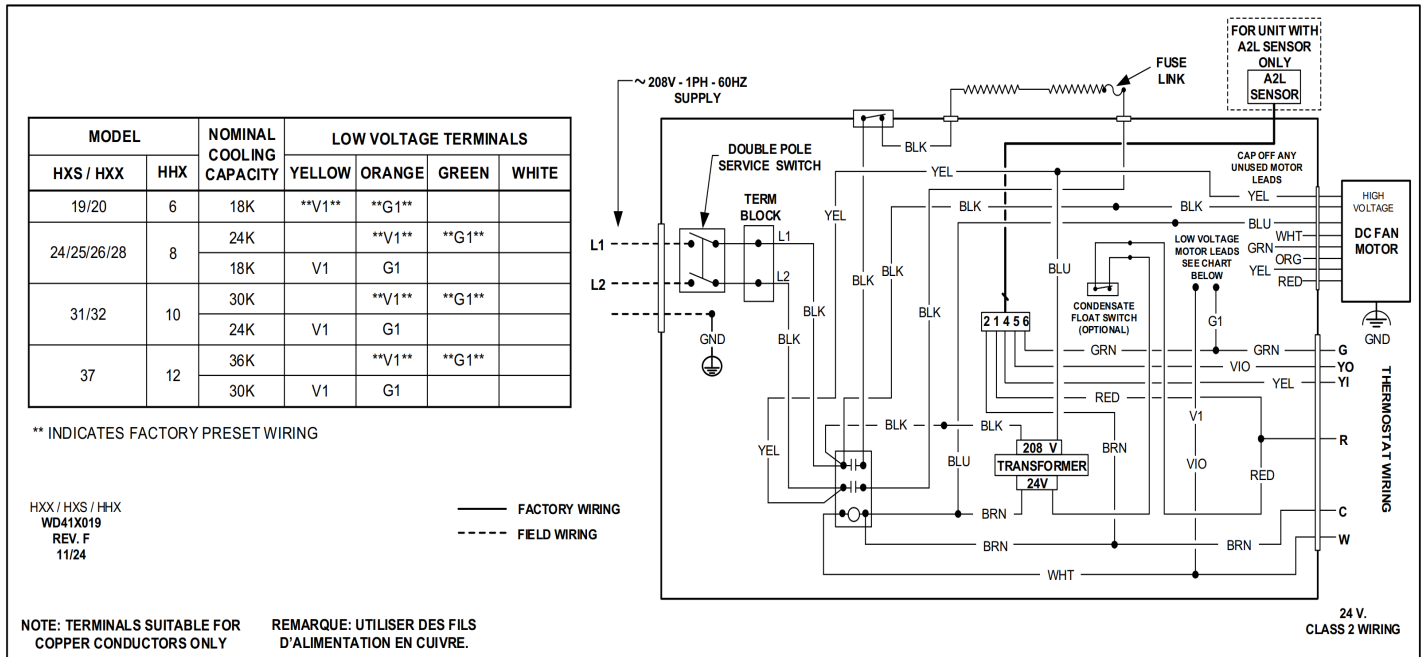

Figure 27 WD41X019

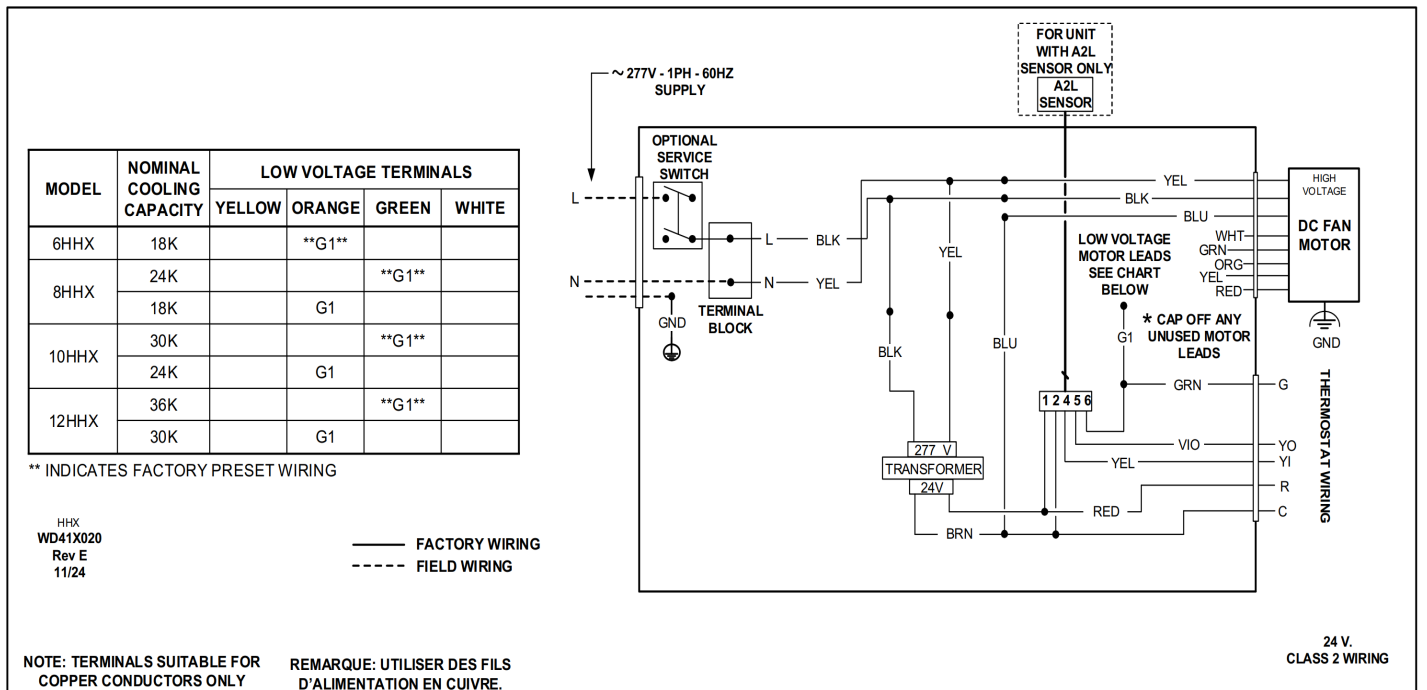

Figure 28 WD41X020

# WIRING DIAGRAMS (CONTINUED)

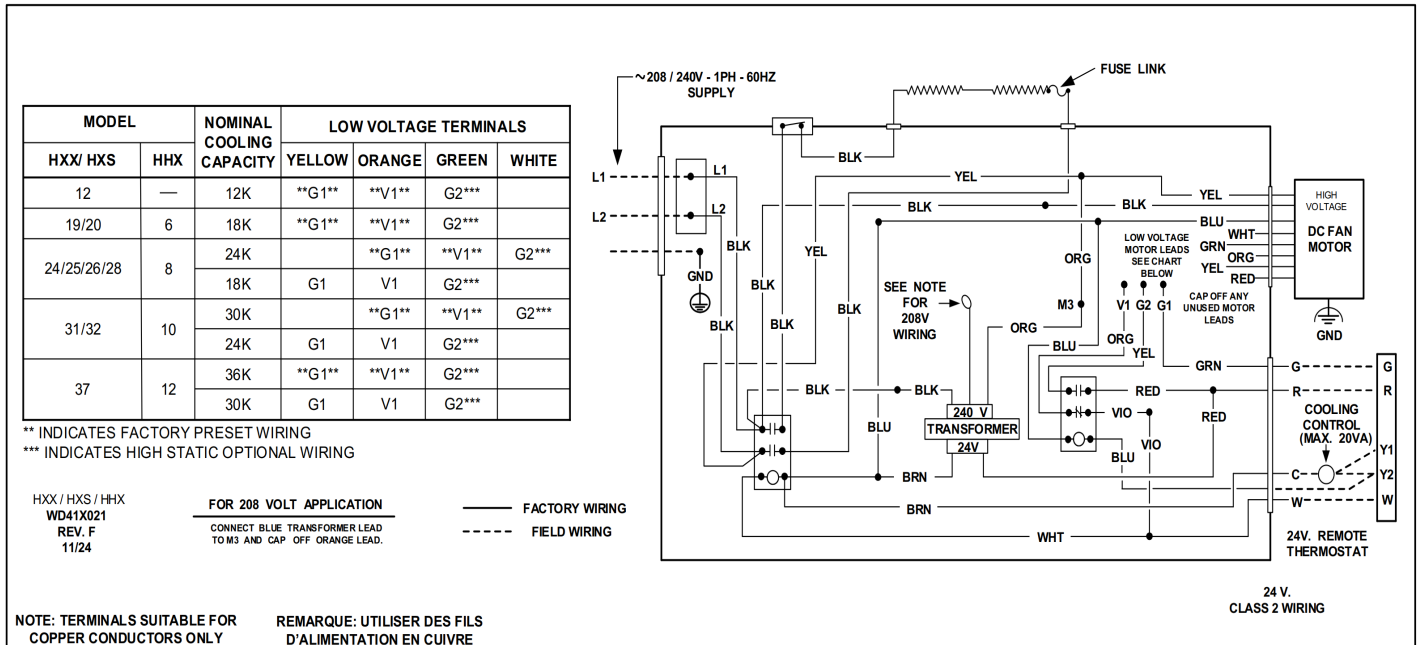

Figure 29 WD41X021

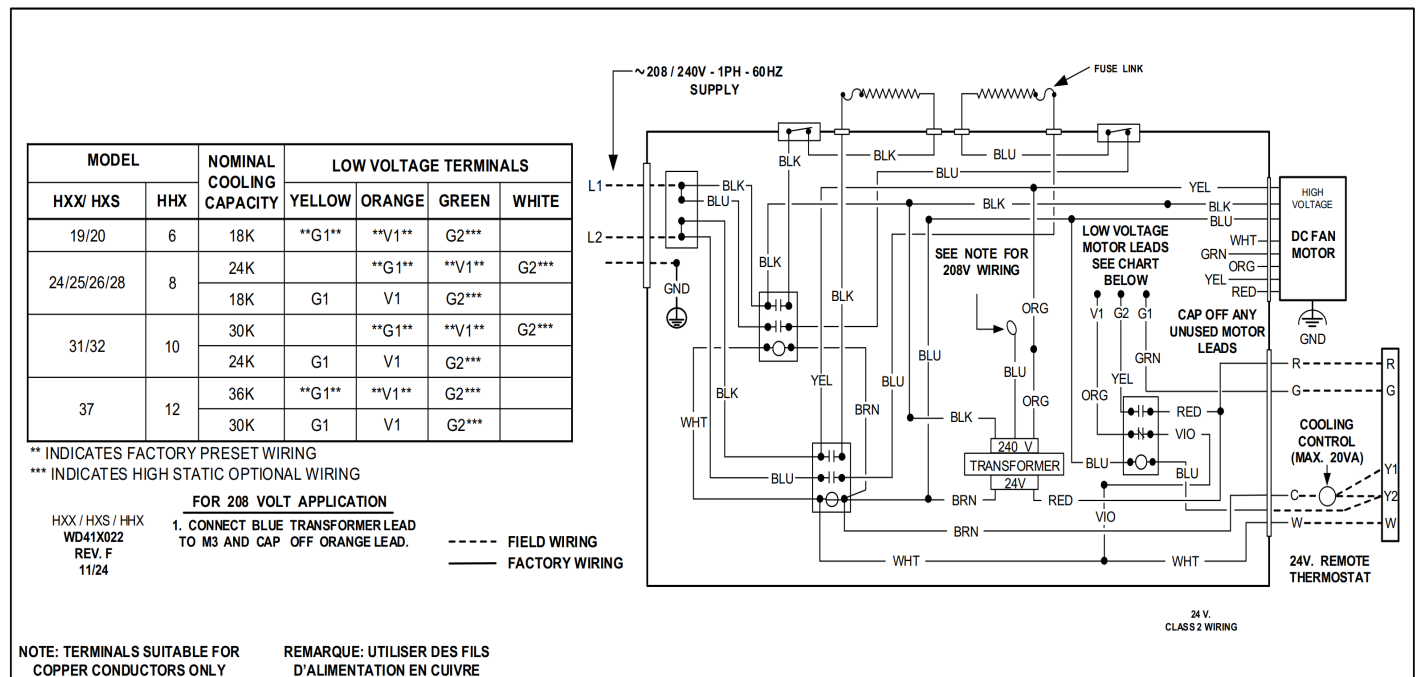

Figure 30 WD41X022

## PIPING PRECAUTIONS

1. Flush all field piping prior to connection to remove all debris.
2. Use wet cotton rags to cool valve bodies when soldering.
3. Open all valves (mid-way for hand valves, manually open on motorized valves) prior to soldering.
4. When soldering to bronze or brass, heat the piping while in the socket/cup and begin introducing the solder when the flux boils rapidly. Avoid direct flame into the solder joint.
5. Heat can only be applied to the cup of the valve body for a minimal time before damage occurs (even with the use of wet rags).
6. Avoid rapid quenching of solder joints as this will produce joints of inferior quality.
7. Provisions must be made for expansion and contraction of piping systems. All horizontal and vertical risers, including runouts, must be able to withstand significant movement with temperature changes. Failure to do so will result in damage and failure of piping, fittings and valves throughout the building.
8. All piping made in the field should be installed with consideration of additional space for any electrical routing that may be required.
9. Connect all piping per accepted industry standards and observe all regulations governing installation of piping systems.

! **CAUTION** !

Hydronic systems are not designed to hold pressurized air and should only be tested with water. Pressurizing system with air could damage equipment.

10. When all connections are complete, pressure test system. Repair any solder joint leaks and gently tighten any leaking valve packing nuts and piping accessories, as required.
11. Connect all piping per accepted industry standards and observe all regulations governing installation of piping systems.
12. When all connections are complete, pressure test system. Repair any solder joint leaks and gently tighten any leaking valve packing nuts and piping accessories, as required.

These units employ a hydronic coil designed for use with either hot or chilledwater.

- All piping must be adequately sized to meet the design water flow requirements as specified for the specific installation. Piping must be installed in accordance with all applicable codes.
- The piping connections on the equipment are not necessarily indicative of the proper supply and return line sizes. To minimize restrictions, piping design should be kept as simple as possible.

! **CAUTION** !

When connecting piping to fan coil units, do not bend or reposition the coil header tubing for alignment purposes. This could cause a tubing fracture resulting in a water leak when pressure is applied to the system.

### CONDENSATE PIPING

Condensate drain lines must be installed with adequate slope away from the unit to assure positive drainage. Since the drain pan is located on the suction side of the blower, a negative pressure exists at the drain pan and a minimum trap of 1-1/2 (3.8 cm) inches should be provided in the drain line to assure proper drainage. The fan coil unit may be located where the return air space is large enough that a negative pressure is not present, however, a trapped condensate line is recommended in case a negative condition should occur, the unit would drain properly.

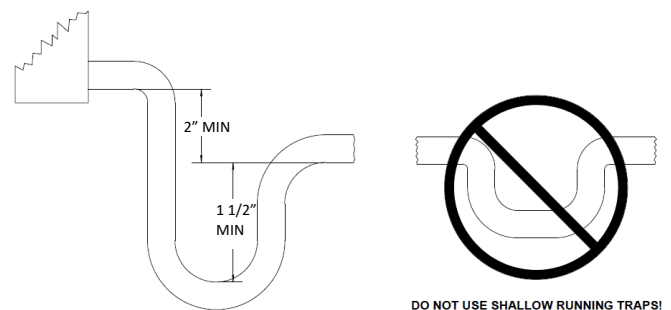

**Figure 31**

## PRE-STARTUP CHECKS

**WARNING**

**ELECTRIC SHOCK HAZARD**

- Electrically ground fan coil. Connect ground wire to ground terminal marked "GND". Failure to do so can result in injury or death.
- Do not touch any rotating component with any object. Damage to the equipment and personal injury can occur.

**CAUTION**

Any device such as a fan switch or thermostat that has been furnished by the factory for field installation must be wired in strict accordance with the wiring diagram that is supplied with the unit. Failure to do so could result in damage to components and will void all warranties.

**WARNING**

**ELECTRIC SHOCK HAZARD**

Transformers are multi voltage, It is crucial to refer to unit wiring diagram, transformers wiring diagram as well as unit voltage to ensure proper connections and operation safety.

Before start-up, all of the components should be given a thorough check. Optimal operation of this equipment requires cleanliness. Often after installation of this equipment additional construction activities occur. Care must be taken to protect the equipment from debris during these construction phases.

Prior to starting the unit:

1. Ensure supply voltage matches nameplate data.
2. Ensure unit is properly grounded.
3. With power off, check blower wheel set-screws for tightness and ensure blower wheels rotate freely and quietly.
4. Ensure fan coil is properly and securely installed.
5. Ensure unit is sloped toward drain line.
6. Ensure unit will be accessible for servicing.
7. Ensure condensate line is properly sized, run, trapped, pitched and tested.
8. Ensure all cabinet openings and wiring connections have been leak checked and insulated as required.
9. Ensure a clean filter is in place and of adequate size.

10. Ensure all access panels are in place and secured.
11. Check that the water coil, valves and piping have been leak checked and insulated as required.
12. Ensure that all air has been vented from the hot water loop.

**NOTE**

It may require purging several gallons of water so have a means of discarding the water.

### MAINTAINING LOW AIR LEAKAGE RATE

During installation, ensure that all grommets and gaskets remain intact on all surfaces as shipped with the unit. Any knockouts, penetrations, and holes that were exposed must be sealed to prevent air leakage. All access panels and covers must be flush with each other and the cabinet. With these requirements satisfied, the unit will maintain and achieve less than 2% air flow leakage when tested in accordance with ASHRAE Standard 193.

## INSTALLATION OF VALVE CLUSTER

Horizontal hydronic fan coil units may use either two-way ( figure 2) or three way ( figure3) motorized valve assembly. The following procedures describe each installation.

### PROCEUDRE 1: TWO WAY ASSEMBLY

1. The two way motorized valve assembly should be attached to the supply header which is the connection nearest the air outlet flange on the unit.
2. Prior to soldering the joints, operate all the hand valves to ensure that the handles will fully open and close without interference to other valves, ceiling wall, plenum or other accessories
3. All valves will operate at any angel with the exception of the motorized valve, which must never be installed with the power head below horizontal. The actuator box requires a 3/4 inch clearance for removal.

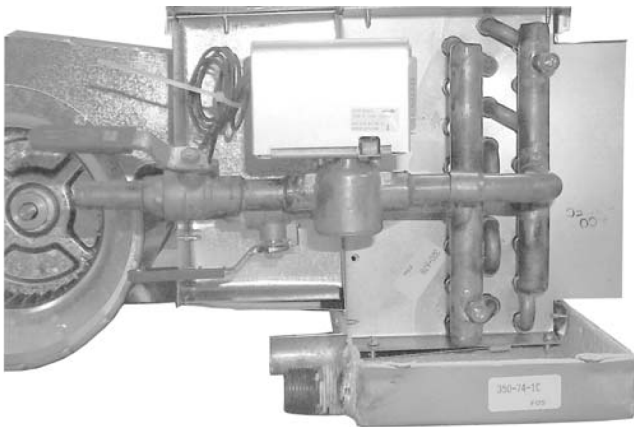

**Figure 32 Two-Way Motorized Valve Assembly**

### PROCEUDRE 2

1. The one way valve assemblies will mount to the coil in only one position.
2. Prior to soldering the joints, operate all the hand valves to ensure that the handles will fully open and close without interference to other valves, ceiling, wall, plenum or other accessories.
3. All valves will operate at any angle with the exception of the motorized valve, which must never be installed with the power head below horizontal. The actuator box requires a 3/4-inch clearance for removal.

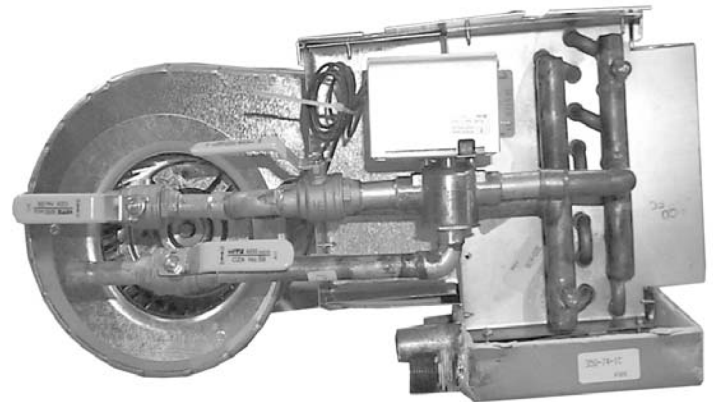

**Figure 33 Three-way Motorized Valve Assembly**

# INSTALLATION OF VALVE CLUSTER (CONTINUED)

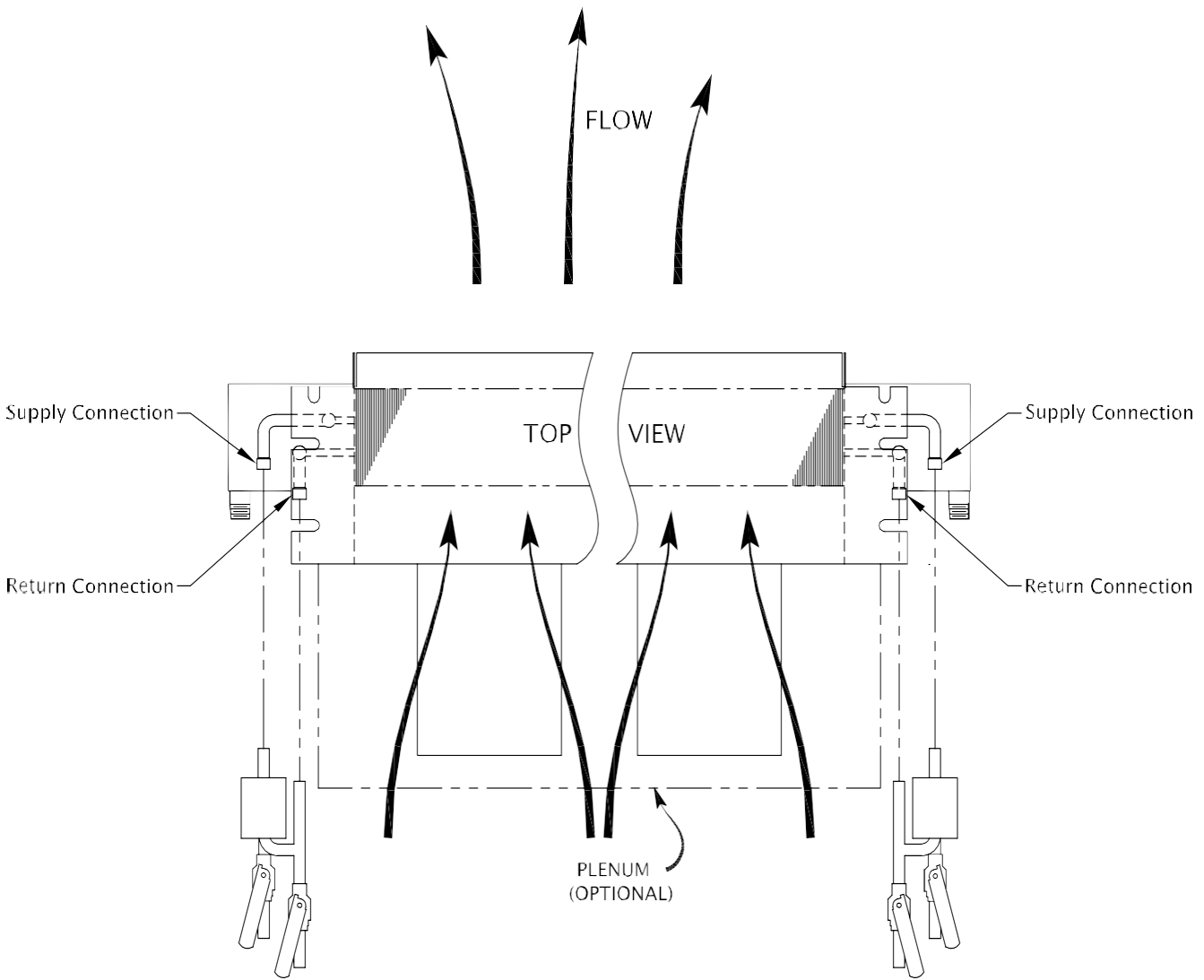

**Figure 34 Determination of Right-Hand/Left-Hand References**

## OPERATION & MAINTENANCE

**WARNING**

**ELECTRIC SHOCK HAZARD**

Failure to follow safety warnings exactly could result in property damage, dangerous operation, serious injury, or death. Improper servicing could result in dangerous operation, serious injury, death, or property damage.

- Before servicing, disconnect all electrical power to the unit.
- When servicing controls, label all wires prior to disconnecting. Reconnect wires correctly. Verify proper operation after servicing.

### FAN

The fan should be inspected and cleaned annually, in conjunction with maintenance of the motor and bearings. It is important to keep the wheels clean in order to avoid imbalance and vibration.

### MOTOR

Check motor connections to ensure that they are secure and made in accordance with the wiring diagram.

**WARNING**

**ELECTRIC SHOCK HAZARD**

Check motor connections to ensure they are secure and in accordance with the unit wiring diagram. ECM motors have line voltage power applied at all times. **MAKE SURE POWER IS DISCONNECTED BEFORE SERVICING**

**WARNING**

Units with ECM motors have line voltage power applied at all times. Make sure power is disconnected before servicing.

The air filter should be cleaned or replaced every 30 days or more frequently if severe conditions exist. Always replace the filter with the same type as originally furnished.

### COIL

Any dust or other contaminants which accumulate on the heat transfer surfaces interferes with the air flow and impairs heat transfer. The coil must be kept clean by any of the following methods.

- Cleaning with low-pressure compressed air.
- Flushing or rinsing with water ( a detergent is advisable for greasy surfaces).

### DRAIN PIPING

The drain should always be:

- Connected or piped to an acceptable disposal point sloped away from the unit at least 1/8-inch per foot.
- Checked before summer operation.

### PREVENTATIVE MAINTENANCE

To achieve maximum performance and service life of each piece of equipment, a formal schedule of regular maintenance should be established and maintained.

### LABORATORY TESTING

When the unit has less than 100 operational hours and the coils have not had sufficient time to be "seasoned", it is necessary to clean the coils with mild surfactant such as Calgon to remove the oils left by manufacturing processes

### FILTER

## OPERATION & MAINTENANCE CONTINUED

Compressor bearing products designed for A2L refrigerants may come equipped with a factory installed refrigerant leak detection system. If the sensor is faulty, or disconnected, the appliance will not properly function.

False ceilings or drop ceilings may be used as a return air plenum if a refrigerant detection system is provided in the appliance and any external connections are also provided with a sensor immediately below the return air plenum duct joint.

### QUALIFICATION OF WORKERS

Service shall only be performed by qualified technicians, certified by national training organizations or manufacturers that are accredited to teach the relevant national competency standards that may be set in legislation. Competence to properly service the appliance should be documented by a certificate.

### CHECKS TO THE WORK AREA

Prior to beginning work on the appliance, safety checks are necessary to ensure that the risk of ignition of released gasses is minimized. Work shall be undertaken under a controlled procedure so as to minimize the risk of a flammable gas or vapor being present while the work is being performed.

All maintenance staff and others working in the local area shall be instructed on the nature of work being carried out. Work in confined spaces shall be avoided.

### CHECKING FOR PRESENCE OF REFRIGERANT

The area shall be checked with an appropriate refrigerant detector prior to and during work, to ensure the technician is aware of potentially toxic or flammable atmospheres. Ensure that the leak detection equipment being used is suitable for use with all applicable refrigerants, i.e. non-sparking, adequately sealed or intrinsically safe.

If any hot work is to be conducted on the refrigerating equipment or any associated parts, appropriate fire extinguishing equipment shall be available to hand. Have a dry powder or CO2 fire extinguisher adjacent to the charging area.

No person carrying out work in relation to a REFRIGERATING SYSTEM which involves exposing any such a pipe work shall use any sources of ignition in manner that it may lead to the risk of fire or explosion.

All possible ignition sources, including cigarette smoking, should be kept sufficiently far away from the site of installation, repairing, removing and disposal, during which refrigerant can possibly be released to the surrounding space. Prior to work taking place, the area around the equipment is to be surveyed to make sure that there are no flammable hazards or ignition risks. "NO SMOKING" signs shall be displayed.

### VENTILATED AREA

Ensure that the area is in the open or that it is adequately ventilated before breaking into the system or conducting any hot work. A degree of ventilation shall continue during the period that the work is carried out. The ventilation should safely disperse any released refrigerant and preferably expel it externally into the atmosphere.

### CHECKS TO THE REFREIGERATING EQUIPMENT

Where electrical components are being changed, they shall be fit for the purpose and to the correct specification. At all times the manufacturer's maintenance and service guidelines shall be followed. If in doubt, consult the manufacturer's technical department for assistance.

The following checks shall be applied to installations using FLAMMANLE REFRIGERANTS:

- The actual REFRIGERANT CHARGE is in accordance with the room size within which the refrigerant containing parts are installed;
- The ventilation machinery and outlets are operating adequately and are not obstructed;
- Marking to the equipment continues to be visible and legible. Markings and signs that are illegible shall be corrected;
- Refrigerating pipe or components are installed in a position where they are unlikely to be exposed to any substance which may corrode refrigerant containing components, unless the components are constructed of materials which are inherently resistant to being corroded or are suitably protected against being so corroded.

## OPERATION & MAINTENANCE CONTINUED

### CHECKS TO ELECTRICAL DEVICES AND SEALED ELECTRICAL COMPONENTS

Repair and maintenance to electrical components shall include initial safety checks and component inspection procedures. If a fault exists that could compromise safety, then no electrical supply shall be connected to the circuit until it is satisfactorily dealt with. If the fault cannot be corrected immediately but it is necessary to continue operation, an adequate temporary solution shall be used. This shall be reported to the owner of the equipment so all parties are advised.

Initial Safety Checks shall include:

- That capacitors are discharged: this shall be done in a safe manner to avoid possibility of sparking;
- That no live electrical components and wiring are exposed while charging, recovering or purging the system;
- That there is continuity of earth bonding.

Sealed electrical components shall be replaced in the event of damage or malfunction.

### CABLING

Check that cabling will not be subject to wear, corrosion, excessive pressure, vibration, sharp edges or any other adverse environmental effects. The check shall also take into account the effects of aging or continual vibration from sources such as compressors or fans.

### DETECTION OF FLAMMABLE REFRIGERANTS

Under no circumstances shall potential sources of ignition be used in the searching for or detection of refrigerant leaks. A halide torch (or any other detector using a naked flame) shall not be used.

Electronic leak detectors may be used to detect refrigerant leaks but, in the case of FLAMMABLE REFRIGERANTS, the sensitivity may not be adequate, or may need re-calibration. (Detection equipment shall be calibrated in a refrigerant-free area.) Ensure that the detector is not a potential source of ignition and is suitable for the refrigerant used. Leak detection equipment shall be set at a percentage of the LFL of the refrigerant and shall be calibrated to the refrigerant employed, and the appropriate percentage of gas (25 % maximum) is confirmed.

Leak detection fluids (such as the bubble method or fluorescent method agents) are also suitable for use with most refrigerants but the use of detergents containing chlorine shall be avoided as the chlorine may react with the refrigerant and corrode the copper pipe-work.

If a leak is suspected, all naked flames shall be removed/extinguished. If a leakage of refrigerant is found which requires brazing, all of the refrigerant shall be recovered from the system, or isolated (by means of shut off valves) in a part of the system remote from the leak.

### REMOVAL AND EVACUATION OF FLAMMABLE REFRIGERANTS

When breaking into the refrigerant circuit to make repairs – or for any other purpose – conventional procedures shall be used. However, for FLAMMABLE REFRIGERANTS it is important that best practice is followed since flammability is a consideration. The following procedure shall be adhered to:

- Remove refrigerant charge following local and national regulations
- Purge the circuit with inert gas (optional for A2L);
- Evacuate (optional for A2L)
- If using flame to open circuit, continuously flush system with an inert gas
- Open the circuit by cutting or brazing.

The refrigerant charge shall be recovered into the correct recovery cylinders if venting is not allowed by local and national codes. For appliances containing flammable refrigerants, the system shall be purged with oxygen-free nitrogen to render the appliance safe for flammable refrigerants. This process might need to be repeated several times. Compressed air or oxygen shall not be used for purging refrigerant systems.

For appliances containing flammable refrigerants, refrigerant purging shall be achieved by breaking the vacuum in the system with oxygen-free nitrogen and continuing until the working pressure is achieved, then venting to the atmosphere, and finally pulling down to a vacuum (optional for A2L). This process shall be repeated until no refrigerant is within the system (optional for A2L). When the final oxygen-free nitrogen charge is used, the system shall be vented down to atmospheric pressure to enable work to take place.

## OPERATION & MAINTENANCE CONTINUED

The outlet for the vacuum pump shall not be close to any potential ignition sources, and ventilation shall be available.

In addition to conventional charging procedures, the following requirements shall be followed.

- Ensure that contamination of different refrigerants does not occur when using charging equipment. Hoses or lines shall be as short as possible to minimize the amount of refrigerant contained in them.
- Cylinders shall be kept in an appropriate position according to the instructions.
- Ensure that the REFRIGERATING SYSTEM is earthed prior to charging the system with refrigerant.
- Label the system when charging is complete (if not already).
- Extreme care shall be taken not to overfill the REFRIGERATING SYSTEM.

Prior to recharging the system, it shall be pressure-tested with the appropriate purging gas. The system shall be leak-tested on completion of charging but prior to commissioning. A follow up leak test shall be carried out prior to leaving the site.

### DECOMMISSIONING

Before carrying out this procedure, it is essential that the technician is completely familiar with the equipment and all its detail. It is recommended good practice that all refrigerants are recovered safely. Prior to the task being carried out, an oil and refrigerant sample shall be taken in case analysis is required prior to re-use of recovered refrigerant. It is essential that electrical power is available before the task is commenced.

- A. Become familiar with the equipment and its operation.
- B. Isolate system electrically.
- C. Before attempting the procedure, ensure that:
  - a. mechanical handling equipment is available, if required, for handling refrigerant cylinders;
  - b. all personal protective equipment is available and being used correctly;
  - c. the recovery process is supervised at all times by a competent person;
  - d. recovery equipment and cylinders conform to the appropriate standards.

- D. Pump down refrigerant system, if possible.
- E. If a vacuum is not possible, make a manifold so that refrigerant can be removed from various parts of the system.
- F. Make sure that cylinder is situated on the scales before recovery takes place.
- G. Start the recovery machine and operate in accordance with instructions.
- H. Do not overfill cylinders (no more than 80 % volume liquid charge).
- I. Do not exceed the maximum working pressure of the cylinder, even temporarily.
- J. When the cylinders have been filled correctly and the process completed, make sure that the cylinders and the equipment are removed from site promptly and all isolation valves on the equipment are closed off.
- K. Recovered refrigerant shall not be charged into another REFRIGERATING SYSTEM unless it has been cleaned and checked.

### LABELING

Equipment shall be labelled stating that it has been decommissioned and emptied of refrigerant. The label shall be dated and signed. For appliances containing FLAMMABLE REFRIGERANTS, ensure that there are labels on the equipment stating that the equipment contains FLAMMABLE REFRIGERANT.

### RECOVERY

When removing refrigerant from a system, either for servicing order commissioning, it is recommended good practice that all refrigerants are removed safely.

When transferring refrigerant into cylinders, ensure that only appropriate refrigerant recovery cylinders are employed. Ensure that the correct number of cylinders for holding the total system charge is available. All cylinders to be used are designated for the recovered refrigerant and labelled for that refrigerant (i.e. special cylinders for the recovery of refrigerant). Cylinders shall be complete with pressure-relief valve and associated shut-off valves in good working order. Empty recovery cylinders are evacuated and, if possible, cooled before recovery occurs.

## OPERATION & MAINTENANCE CONTINUED

---

The recovery equipment shall be in good working order with a set of instructions concerning the equipment that is at hand and shall be suitable for the recovery of the flammable refrigerant. If in doubt, the manufacturer should be consulted. In addition, a set of calibrated weighing scales shall be available and in good working order. Hoses shall be complete with leak-free disconnect couplings and in good condition.

The recovered refrigerant shall be processed according to local Legislation in the correct recovery cylinder, and the relevant waste transfer note arranged. Do not mix refrigerants in recovery units and especially not in cylinders.

If compressors or compressor oils are to be removed, ensure that they have been evacuated to an acceptable level to make certain that flammable refrigerant does not remain within the lubricant. The compressor body shall not be heated by an open flame or other ignition sources to accelerate this process. When oil is drained from a system, it shall be carried out safely

### **REFRIGERANT DETECTION SENSOR (RDS) INFORMATION**

Refer to the appliance IOM for information regarding the minimum conditioned room requirements, and instructions for the RDS operation, installation, and wiring. Any field installed wiring connected to the RDS must be at least 18AWG and have minimum insulation thickness of 1.58mm or be protected from damage.

The RDS is not intended for service or repair. In the event of a sensor failure, the mitigation mode will engage and the sensor shall be replaced by removing the sensor and replacing it with a new sensor.

# NOTES

---



P.O. Box 270969 Dallas, TX 75227  
[www.firstco.com](http://www.firstco.com) or [www.ae-air.com](http://www.ae-air.com)

The manufacturer works to continually improve its products. It reserves the right to change design and specifications without notice.

©2022 First Co., Applied Environmental Air