



# FRESH-PAK HP

*Space Constrained Heat Pump*  
with Electric Heating and Fully Integrated ERV (EPE)

1.0 – 2.5 Tons

3 to 10 kW Electric Heat

11.9 SEER2 & 6.3 HSPF2

**eco**series  
FRESH-PAK



---

# TABLE OF CONTENTS

NOMENCLATURE .....	3
SERIES FEATURES .....	4
ERV DATA .....	7
REQUIRED ACCESSORIES .....	8
WALL SLEEVE ERV DUCTING .....	9
DEFROST DUCTING.....	10
LOUVERS .....	11
CONTROLS .....	12
GENERAL ASSEMBLY AND MAJOR COMPONENTS .....	13
SIMPLIFIED CONTROL MAJOR COMPONENTS.....	14
OPTIONAL ACCESSORIES .....	15
ERV SENSOR.....	16
DIMENSIONS .....	17-18
PHYSICAL DATA .....	19
ELECTRICAL DATA.....	20
HEATING AND COOLING PERFORMANCE .....	21
COMBINED EXTENDED HEATING PERFORMANCE .....	22
EXTENDED COOLING PERFORMANCE.....	23
BLOWER PERFORMANCE .....	24-25
ERV FAN PERFORMANCE.....	26-28

To determine certified indoor/outdoor combinations, go to [www.firstco.com](http://www.firstco.com) or contact the factory.

In keeping with its policy of continuous progress and product improvement, First Co. reserves the right to make changes without notice.

# NOMENCLATURE

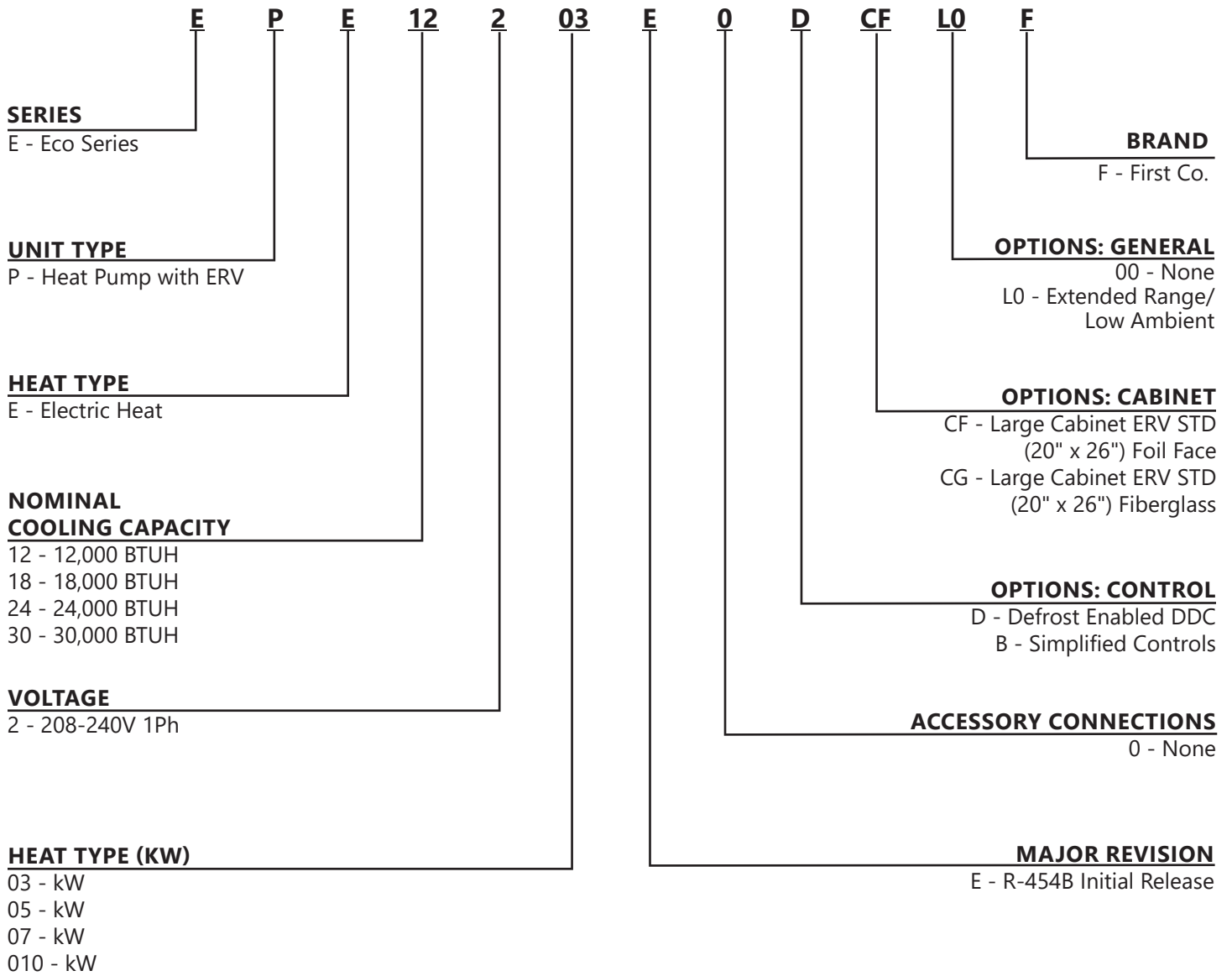

---

# FRESH-PAK HP

## SPACE CONSTRAINED HEAT PUMP

### PRODUCT DESCRIPTION

- Space constrained low ambient heat pump with integrated energy recovery ventilator (ERV)
- Pre-wired and pre-charged with R-454B refrigerant, capable of delivering conditioned air to multiple rooms
- Easily installs into a closet or mechanical room on an exterior wall, utilizing a minimal amount of floor space
- Controlled by a standard low voltage heat pump thermostat with ventilation capabilities

### APPLICATIONS

Hospitality, Apartments/Condominiums, Assisted Living/Memory Care, Student Housing, Senior Living and Modular/Prefabricated Buildings

### STANDARD FEATURES

- Shipped ready for top supply and front return (with optional ducted return)
- Insulated compartment to improve cooling performance, reduce noise, and prevent sweating
- ECM indoor blower & outdoor fan motor to provide precise airflow selection and improve system efficiency
- High-efficiency two stage scroll, single stage scroll and rotary compressors with double isolated compressor mount to lower compressor noise and vibration
- Larger evaporator coil with low face velocity for improved cooling performance
- Drain pan with corrosion resistant coating to drain condensate in cooling and heating operations
- Thermal expansion valve (TXV) for both cooling and heating to optimize performance
- Operates down to as low as 5°F ambient temperature with time-temperature defrost board with selectable defrost interval times
- High and low pressure switch protection
- Electric heat with automatic reset limit switch and non-resettable fuse link
- Filter brackets and disposable filter shipped with unit for field installation; no tool needed to replace filter
- Multi-function microprocessor control board
- Factory installed condensate float switch for overflow protection
- Refrigerant leak migration on units over 4lbs of charge

### SERVICEABILITY FEATURES

- Easy access for in-place service of most components
- All electrical components and control boards are serviceable from front of the unit

### WARRANTY

Five (5) year limited warranty on compressor and part

### REQUIRED ACCESSORIES

- Single piece weight bearing wall sleeves with integrated ventilation air intake and exhaust ports for various wall thicknesses from 5" to 20"
- Flush type aluminum louver with finish and paint options
- Standard low voltage heat pump thermostat with ventilation capabilities
- WLAN service stick to program ERV control board (not required on Simplified Controls Package).

# FRESH-PAK HP

## SPACE CONSTRAINED HEAT PUMP

### OPTIONAL ACCESSORIES

- Interior Access Panels - Louvered or Solid
- ERV Sensors - Humidity or Carbon Dioxide (field provided)
- ERV Exhaust Controls - Analog Egg Timer or Digital Timer Switch (field provided)

### STANDARD UNIT FEATURES

**Ductwork Connections** - Shipped ready for top supply duct connection and front non-ducted return with optional ducted return. If require by code, return air can be ducted to the unit.

**NOTE:** If ducted return is utilized, the filter will need to be relocated to a suitable location outside the cabinet for ease of service.

**Filter Rack** - Filter brackets and a disposable filter ship with each unit to be field installed over the evaporator coil.

**NOTE:** Do not use filters which will cause the total external static pressure, including ducts, louvers, registers, and filters to exceed 0.5 in. w.c.

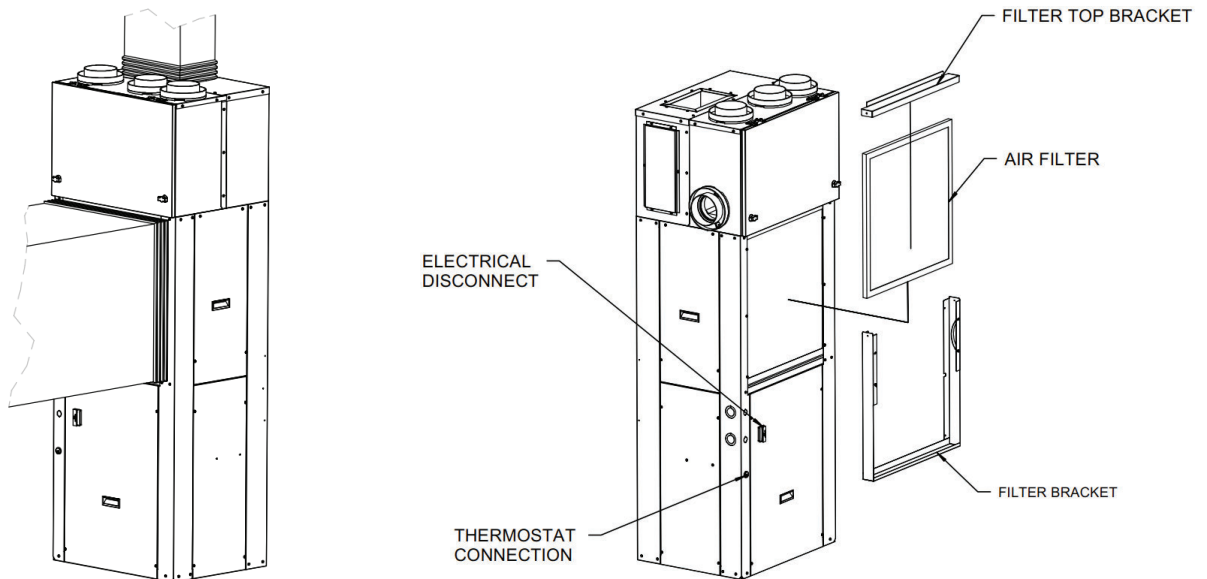

### MULTI-FUNCTION MICROPROCESSOR CONTROL BOARD

**Evaporator coil low temperature protection** – During the cooling mode, should the evaporator coil experience either a low temperature condition that could result in ice buildup on the coil or a reduced air flow situation, a temperature sensor attached to the coil will de-energize the unit. The sensor will re-energize the unit when the coil warms back up.

**Random restart** – When power is turned on after a power outage, a built-in random restart delay of 3-4 minutes prevents all compressors from restarting simultaneously.

**Compressor restart delay** – This delay ensures that system pressures are allowed to equalize before a compressor restart, which extends compressor life.

**Fan delay** – A fan delay allows the evaporator blower to continue running for up to 45 seconds after the thermostat is satisfied which maximizes cooling performance.

**Defrost controls** - During the heating mode, if conditions for frost build-up are detected in the outdoor section, the unit will enter a temporary defrost mode to thaw the condenser coil and allow the unit to continue operation down to 5°F.

# FRESH-PAK HP

## SPACE CONSTRAINED HEAT PUMP

### SERVICE PULL OUT SWITCH

Provides a visible means of disconnect when performing maintenance; models with 10 kW electric heat also have terminal block.

**WARNING:** The incoming conductors of the service switch remain energized when the service switch is pulled out. Always disconnect power at the main source as well as the service switch before servicing. All lockout/tag out procedures must be followed.

### CONDENSATE SYSTEM

#### Primary Condensate

Factory installed drain line connects the evaporator drain pan to a vertical pipe connection in the unit base pan. Evaporator condensate is delivered from the unit to a catch tray in the wall sleeve and exits the sleeve through the 3/4" male NPT fitting. This design allows the plumber to completely pipe the drain to a condensate riser during the rough-in stage, thus eliminating condensate connection problems usually encountered when trying to connect the HVAC drain to the riser after the HVAC unit is installed in the closet. This features also allows the unit to be removed for service without disconnecting the condensate piping. This configuration does not require any additional closet space to make the drain connection, as do some competitive products.

#### Secondary Condensate

If for any reason, the primary condensate riser becomes clogged, water will fill the catch tray and then be diverted through the wall sleeve to the exterior of the building, rather than be allowed to overflow into the closet or living area. Rain water entering the wall sleeve is automatically diverted to the condensate drain.

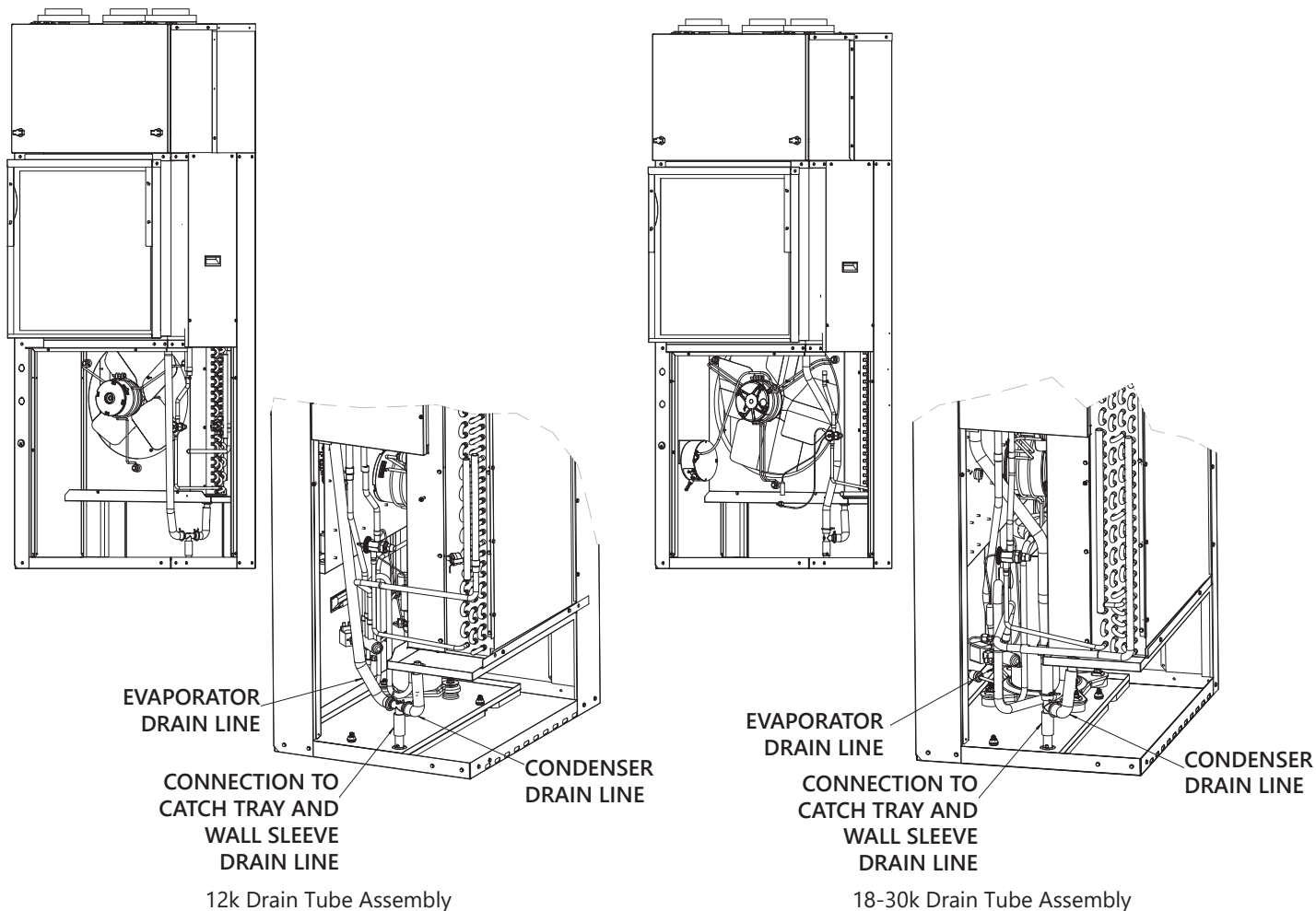

# FRESH-PAK HP

## SPACE CONSTRAINED HEAT PUMP

### WHAT IS ERV ?

**ENERGY RECOVERY VENTILATOR (ERV)** is a device that uses waste/stale air to precondition incoming outside/fresh air for ventilation.

**ERV** uses a polymer core to transfer temperature (sensible energy) and moisture (latent energy) from waste air to incoming ventilation air. It will cool the air in the warmer months and warm the air in the colder months.

Tighter construction requirements create less natural ventilation, the **ERV** offers the solution with balanced ventilation.

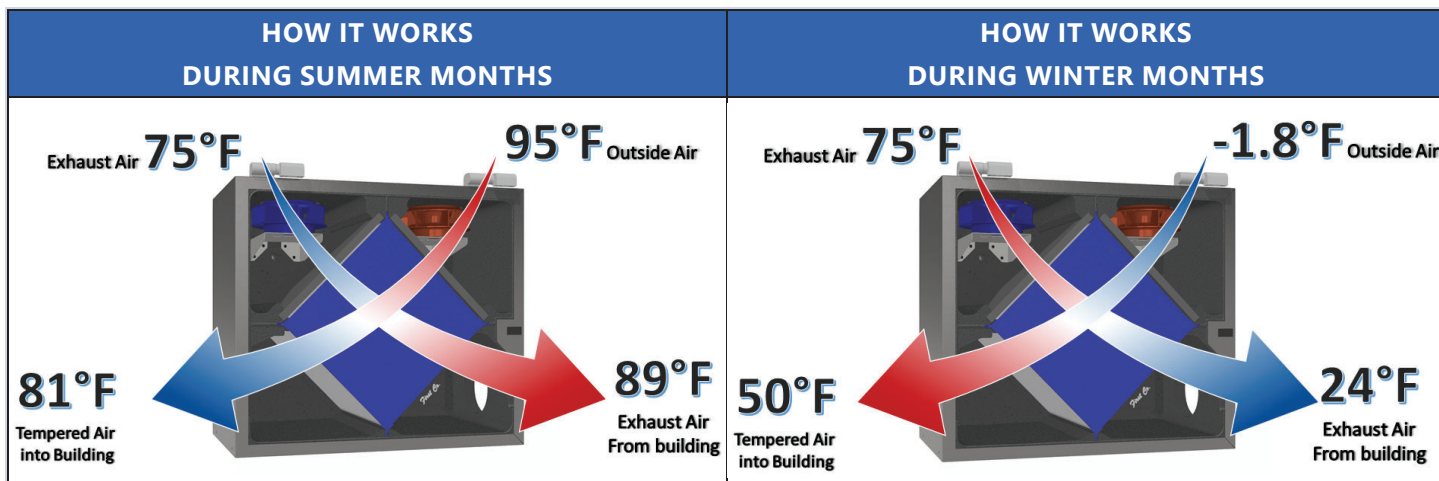

### INTEGRATED ENERGY RECOVERY VENTILATOR (ERV)

- Core Enclosure: Insulated one piece molded enclosure, made from mold/mildew resistant material. Completely sealed providing noise and air leakage reduction
- Core: Full enthalpy core made from polymer material that is removable for servicing & cleaning
- Core Filters: Filtration of ventilation air & return air with MERV 5 washable and disposable filters



**DEFROST** – The ERV will sense when the exhaust drops below the set temperature and will activate the built-in multi-stage defrost mode. The first stage will reduce the fan speed to help warm up the core and prevent freezing. The second stage will, if optional, activate a 3rd party field installed electric preheater.

The ERV will cycle between defrost and normal operation until the temperature rises to the set point. It can be field configured so the supply fan can be switched off while the exhaust runs to warm up the core.

# FRESH-PAK HP

## SPACE CONSTRAINED HEAT PUMP

### REQUIRED ACCESSORIES

**WALL SLEEVE, LOUVER AND THERMOSTAT ARE REQUIRED FOR EACH INSTALLATION**

#### WALL SLEEVES

- Fresh air intake and exhaust ports are built in to wall sleeve
- Provided for installation during rough-in or when ready the unit is slid into the wall sleeve and ductwork and electrical are connected.
- Weight bearing wall sleeve that supports the entire weight of the unit and provides a weather tight seal against wind and water infiltration
- Four wall sleeve depths are available to accommodate wall thickness from 5" to 20".
- Includes a weather guard to cover the sleeve opening and a debris guard to cover wall sleeve base and drain during construction

ACCESSORY	DESCRIPTION	DIMENSIONS (H x W x D)	PART #	A	B	C
<b>FRESH-PAK INTEGRATED TOP PORTS</b>	For 5" - 8" thick walls	43-1/4 x 26-1/2 x 37-1/4	999-21B-E	16-3/4"	20-15/16"	37-11/16"
	For 8" - 12" thick walls	43-1/4 x 26-1/2 x 41-1/4	999-22B-E	20-3/4"	20-15/16"	41-11/16"
	For 12" - 15" thick walls	43-1/4 x 26-1/2 x 44-1/4	999-23B-E	23-3/4"	20-15/16"	44-11/16"
	For 15" - 20" thick walls	43-1/4 x 26-1/2 x 50-1/4	999-24B-E	29-3/4"	20-15/16"	50-11/16"

All wall sleeves are shipped two (2) per carton, fully assembled.

**Wall sleeve, louver and thermostat are required for each installation.**

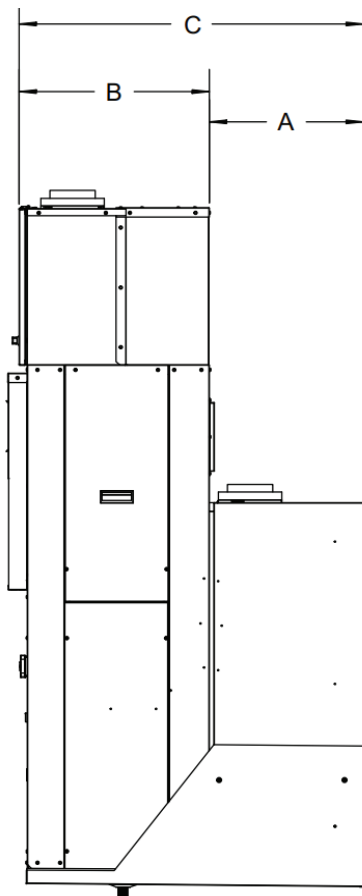

WALL SLEEVE WITH TOP PORTS

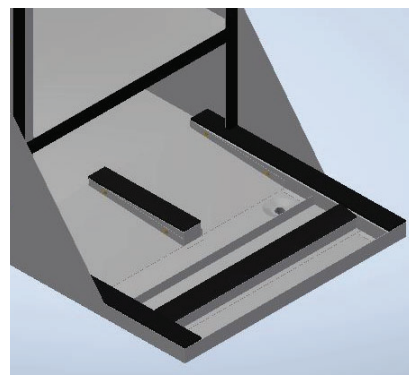
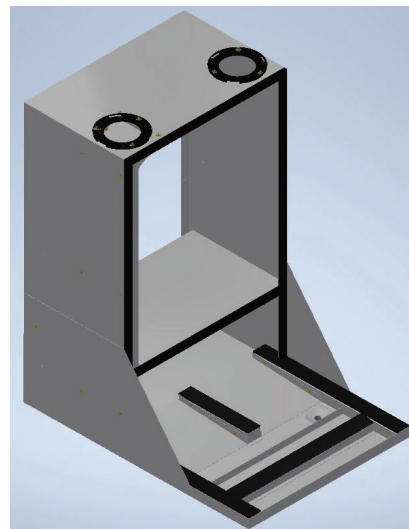

WALL SLEEVE CONDENSATE DRAIN

# FRESH-PAK HP

## SPACE CONSTRAINED HEAT PUMP

### WALL SLEEVE ERV DUCTING



Top Ducted Installation

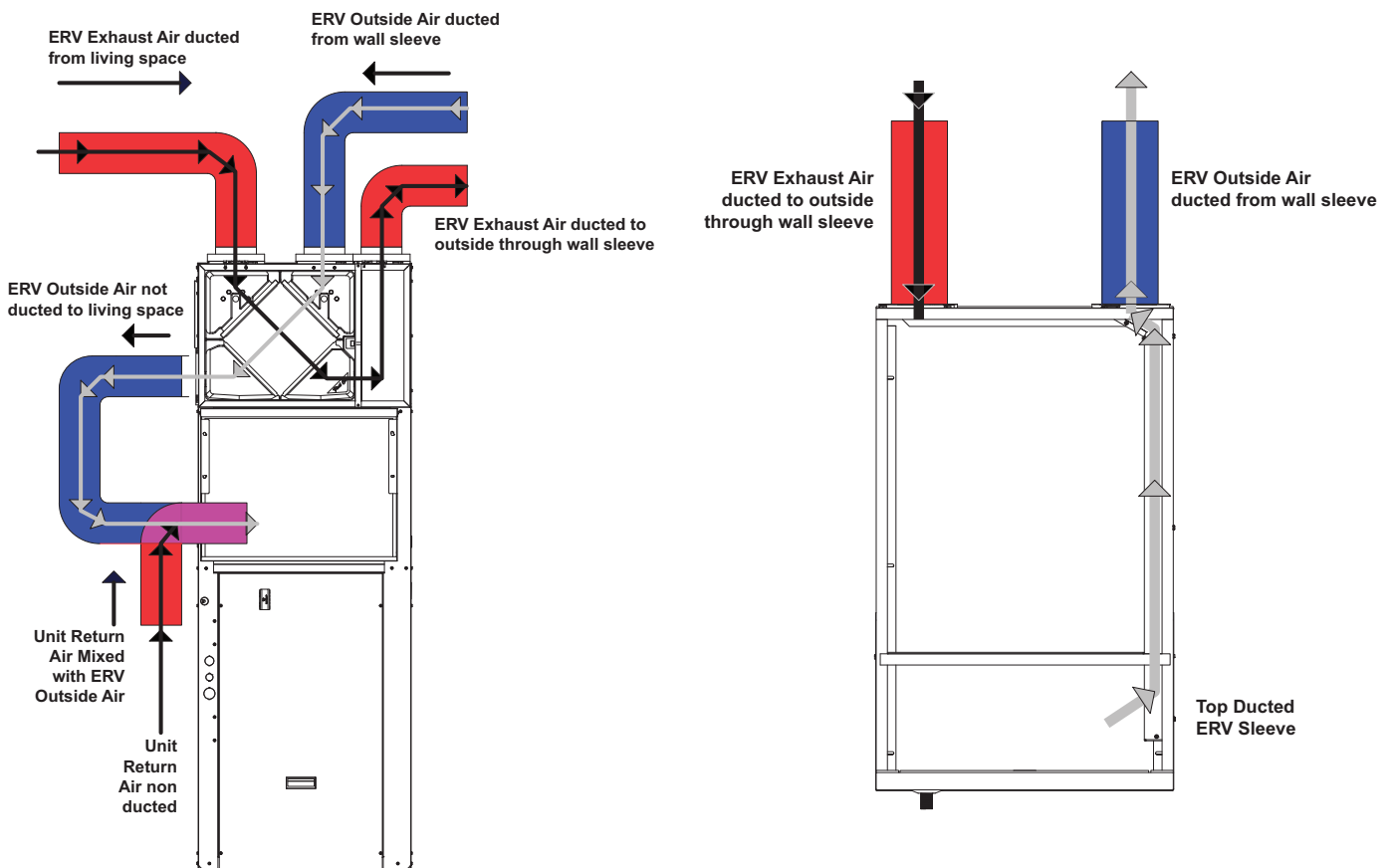

# FRESH-PAK HP

SPACE CONSTRAINED HEAT PUMP

## DEFROST DUCTING, SIMPLIFIED CONTROLS

OPTION 1 – ELECTRIC PREHEAT

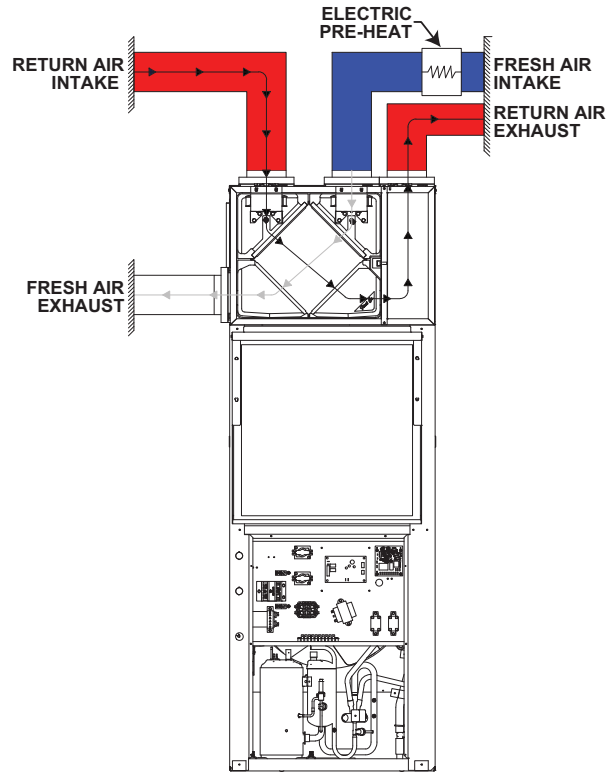

## OPTION 2 – RECIRCULATION DAMPER

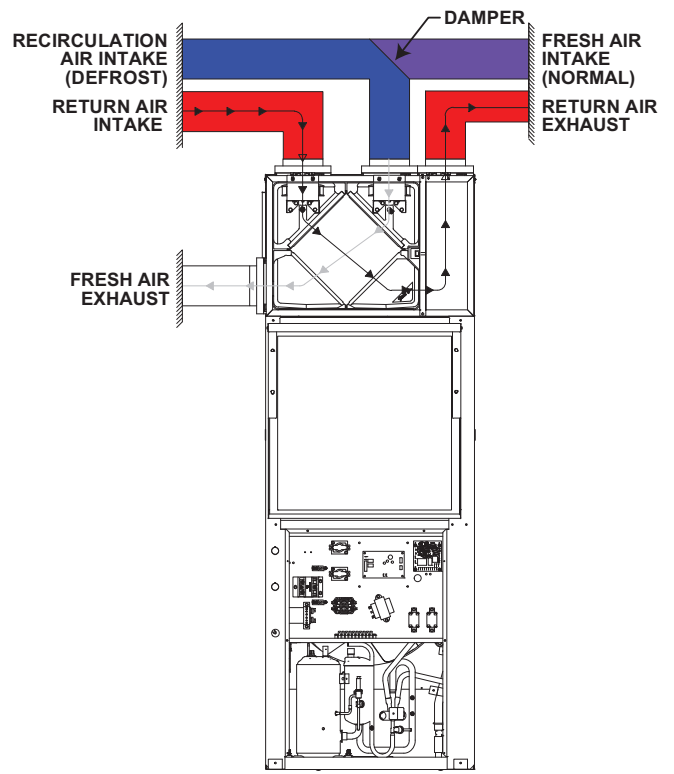
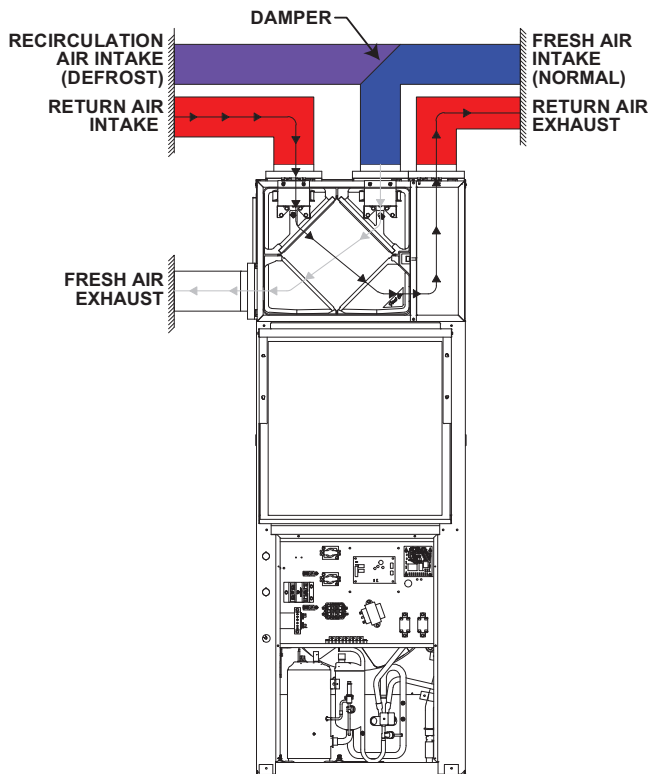

# FRESH-PAK HP

## SPACE CONSTRAINED HEAT PUMP

### LOUVERS

Extruded aluminum louver that attaches to the outside face of the wall sleeve. The blades of this unique louver recess into the wall sleeve for a neat, flush appearance.

Louver attachment screws are tightened from inside of the wall sleeve. Do not install the unit into the wall sleeve before installing the louver and tightening attachment screws.

DESCRIPTION	DIMENSIONS (H x W x D)	PART NUMBER
Field Painted	43-1/2 x 26-1/8	G8502PPA
Anodized Clear Coat	43-1/2 x 26-1/8	G8501A
Custom Painted	43-1/2 x 26-1/8	G8503S*

S\* indicates custom color, to be provided by customer. Minimum order quantity is 15 per color, if less than 15 set up fees will be applied

### STANDARD PAINT COLORS:

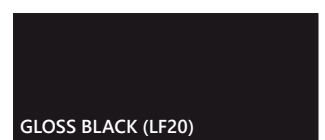
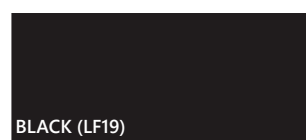
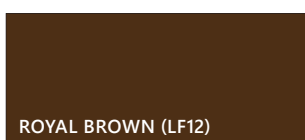
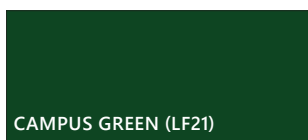
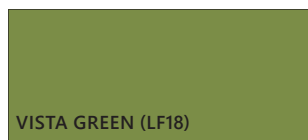
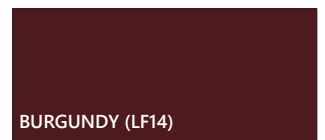
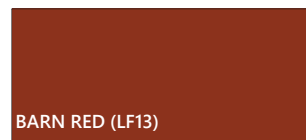
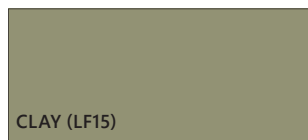
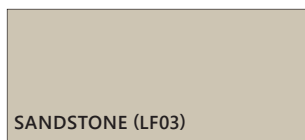
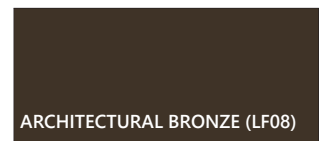
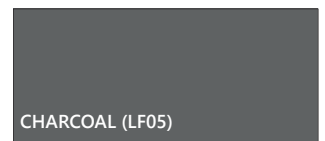
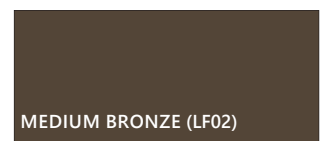
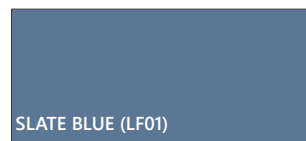
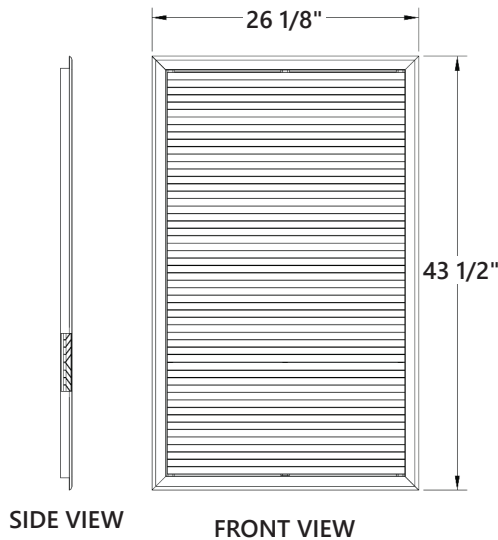

# FRESH-PAK HP

## SPACE CONSTRAINED HEAT PUMP

### CONTROLS

#### THERMOSTATS

Units are controlled by a standard low voltage heat pump thermostat with ventilation capabilities.

BRAND	DESCRIPTION	PART NUMBER	IMAGE
Honeywell	Programmable 7-day/5-2/5-1-1 3H/2C HP 2H/2C Conv. 24v Hardwired, C-wire only, Wi-Fi, aux heat lockout w/ventilation control	THX321WF3003W	

**NOTE:** The use of a Heat Pump thermostat is required for proper unit operation. It is highly suggested to set the balance point control to 35°F to improve occupant comfort.

#### WLAN SERVICE STICK

ERV Programming via WLAN\* service stick - Must purchase one stick per project. Required to program ERV board through the ABT GO app.

PART NUMBER	IMAGE
USB-300	

\*WLAN = wireless local area network

**NOTE:**

Only required on Standard Controls Package. Simplified Controls Package can be programmed without a service stick.

# FRESH-PAK HP

## SPACE CONSTRAINED HEAT PUMP

### GENERAL ASSEMBLY AND MAJOR COMPONENTS

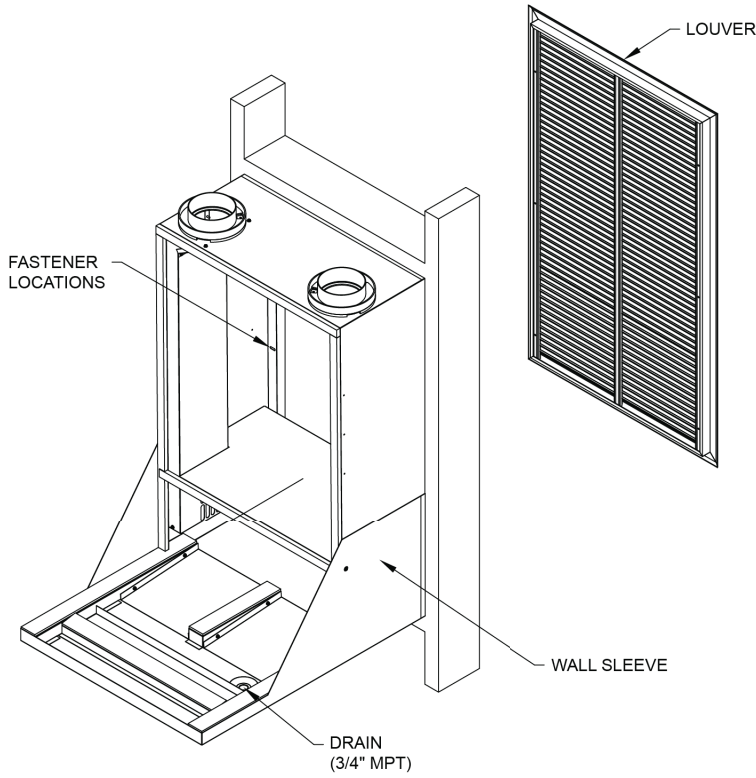

**GENERAL ASSEMBLY FOR WALL SLEEVE AND LOUVER**

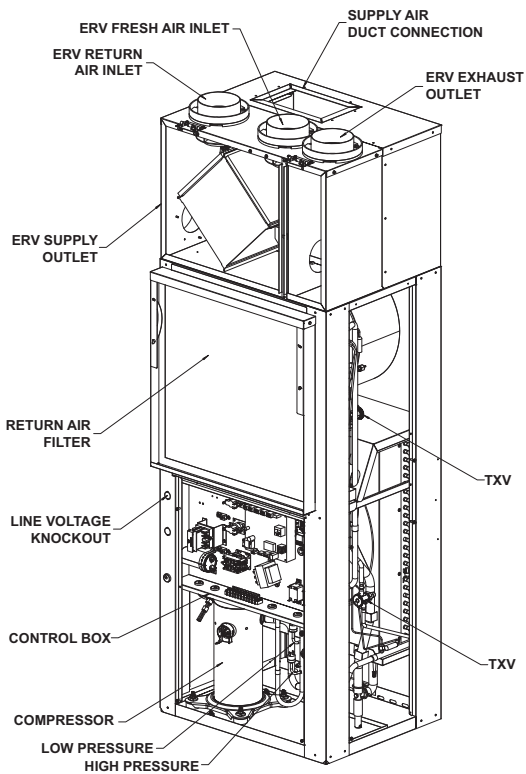

**MAJOR COMPONENTS**

# FRESH-PAK HP

SPACE CONSTRAINED HEAT PUMP

## SIMPLIFIED CONTROL MAJOR COMPONENTS

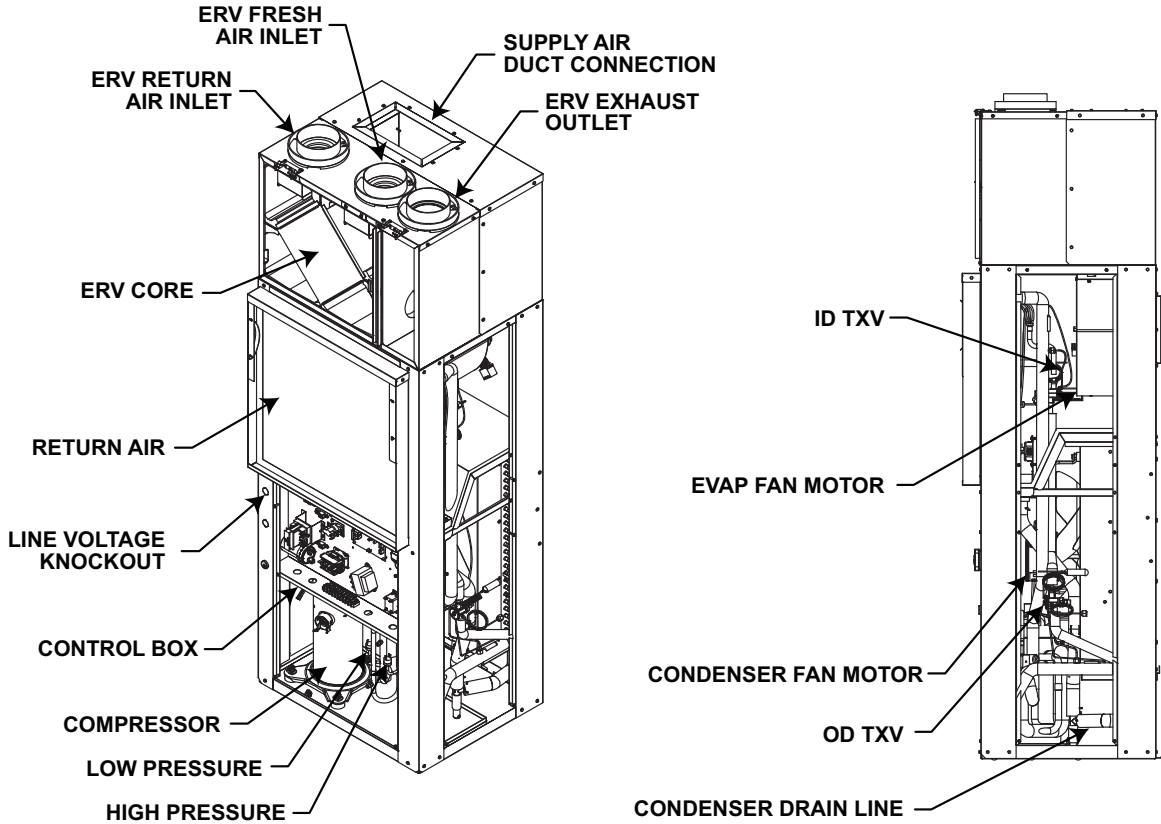

SIZE 12 UNITS ONLY

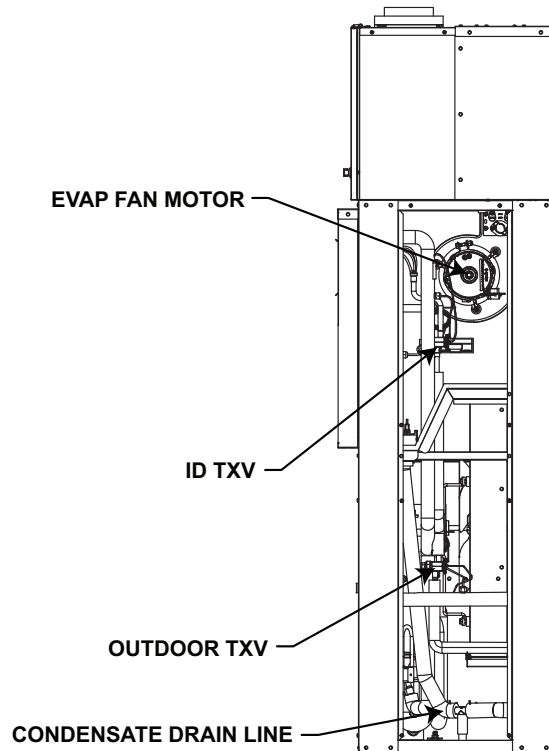

# FRESH-PAK HP

## SPACE CONSTRAINED HEAT PUMP

### OPTIONAL ACCESSORIES

#### ACCESS PANELS

COMPONENT	DESCRIPTION	FRAME (A x C)	OPENING (B x D)	PART NUMBER	SHIPPING WEIGHT LBS.
RETURN AIR PANEL	LOUVERED	87 X 37	84 X 34	931-20	55
ACCESS PANEL	SOLID	87 X 37	84 X 34	931-16	55

**NOTE:**

No filter provided, requires unit mounted filter.

Both panels are insulated for sound reduction and have tamperproof screws.

Panels are shipped ten per carton.

A solid door or panel with a side wall return air grille will result in lower sound levels.







# FRESH-PAK HP

## SPACE CONSTRAINED HEAT PUMP

### ERV SENSORS

#### FIELD PROVIDED

- Humidity: Measures temperature and air humidity, signals ERV board to bring on ventilation
- Carbon Dioxide (CO2): Used for determining ventilation necessity and to manage the amount of ventilation air supplied to maintain acceptable levels of CO2 in the space

BRAND	DESCRIPTION	PART NUMBER	IMAGE
Honeywell	Carbon Dioxide (CO2) Sensor Duct mounted no display	C7232	
Honeywell	Carbon Dioxide (CO2) Sensor wall mounted sensor with LED light display	C7233	
Honeywell	Carbon Dioxide (CO2) Sensor wall mounted sensor with digital display	C7263	
PCE	Humidity Sensor wall mounted 4 – 20 mA output	PCE-P18	
Honeywell	Humidistat wall mounted HumidiPRO Digital Humidity Control	H6062	

### ERV EXHAUST SENSORS

#### FIELD PROVIDED

- Analog Egg Timer
- Digital Timer Switch

# FRESH-PAK HP

## SPACE CONSTRAINED HEAT PUMP

### PHYSICAL DATA

#### UNIT DIMENSIONS 12K

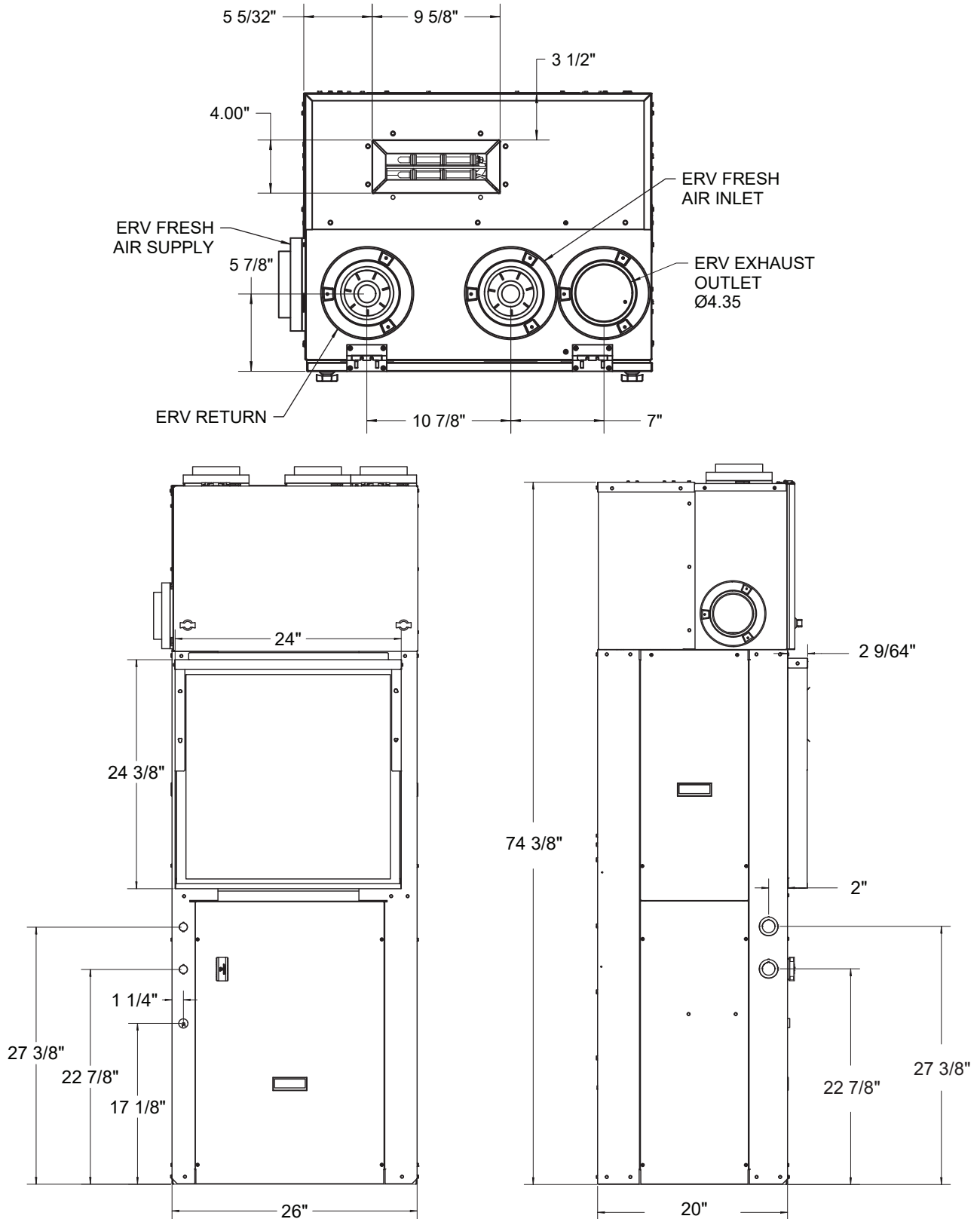

# FRESH-PAK HP

SPACE CONSTRAINED HEAT PUMP

## PHYSICAL DATA

UNIT DIMENSIONS 18-30K

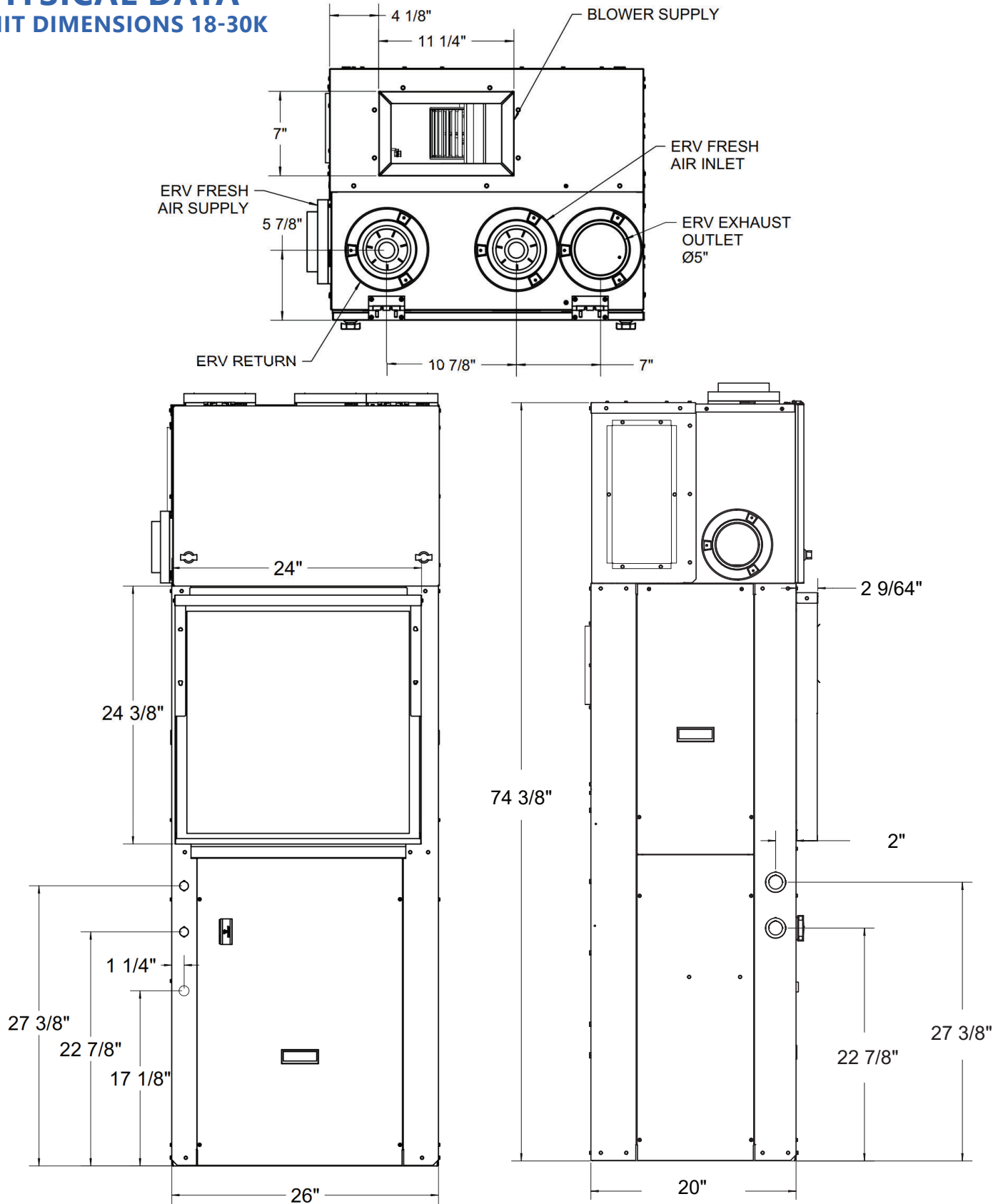

# FRESH-PAK HP

## SPACE CONSTRAINED HEAT PUMP

### PHYSICAL DATA

PHYSICAL DATA					
454B FRESH PAK AC		EPE12	EPE18	EPE24	EPE30
Compressor (Quantity)		Rotary (1)	Scroll (1)	Scroll (1)	Scroll (1)
Compressor FLA		4.6	7.2	10.2	12.8
Factory Charge (R454B)	lb	3.375	4.5	5	5.75
	kg	1.53	2.04	2.26	2.6
Minimum Room Area	m <sup>2</sup>	4.6	6.2	6.8	7.9
Minimum Room Area	Ft <sup>2</sup>	49.7	66.3	73.5	84.5
Minimum Air Flow	CFM	91	122	135	155
	M3/hr	155	207	229	264
ID MOTOR					
Motor (Quantity)		1	1	1	1
Fan Motor Type		ECM	ECM	ECM	ECM
Motor HP		1/4	1/3	1/3	1/2
Motor FLA		2.3	2.8	2.8	4.1
OD MOTOR					
Motor (Quantity)		1	1	1	1
Fan Motor Type		ECM	ECM	ECM	ECM
Motor HP		1/4	1/3	1/3	1/3
Motor FLA		2.3	2.8	2.8	2.8
ID BLOWER					
Blowers (Quantity)		1	1	1	1
Blower Wheel Size (D x W) in. [cm]		6 x 8	10 x 4	10 x 4	10 x 4
		[15.24 x 20.32]	[25.4 x 10.16]	[25.4 x 10.16]	[25.4 x 10.16]
EVAPORATOR COIL					
Dimensions (H x W) in. [cm]		24 x 16.25	24x22	24x22	24x22
		[61 x 41.275]	[61 x 55.88]	[61 x 55.88]	[61 x 55.88]
Face Area ft <sup>2</sup> [m <sup>2</sup> ]		3.53 [2.70]	3.53 [0.33]	3.53 [0.33]	3.53 [0.33]
Rows		3	4	4	4
OD COIL					
Dimensions (H x W) in. [cm]		26 x 16.5	26 x 22.5	26 x 22.5	26 x 22.5
		[66 x 42]	[66 x 57]	[66 x 57]	[66 x 57]
Face Area ft <sup>2</sup> [m <sup>2</sup> ]		3.0 [0.2772]	4.1 [0.3762]	4.1 [0.3762]	4.1 [0.3762]
MISCELLANEOUS					
Throwaway Filter Dim. in. [cm]		24 x 24	24 x 24	24 x 24	24 x 24
		[60.96 x 60.96]	[60.96 x 60.96]	[60.96 x 60.96]	[60.96 x 60.96]
Throwaway Filter Quantity		1	1	1	1
A2L MITIGATION		NO	YES	YES	YES
Operating Weight lb. [kg]		275 [124.7]	290 [131.5]	305 [138.3]	310 [140.6]
Packaged Weight lb. [kg]		295 [133.8]	310 [140.6]	325 [147.4]	330 [149.7]

# FRESH-PAK HP

## SPACE CONSTRAINED HEAT PUMP

### ELECTRICAL DATA

ELECTRICAL DATA (208/240V 1-PH-60HZ)																					
UNIT MODEL		ELECTRICAL HEAT DATA						BLOWER DATA		CONDENSER DATA				MINIMUM CIRCUIT AMAPACITY				MAXIMUM CIRCUIT PROTECTION			
		KW		BTUH		TOTAL HEATING AMPS		EVAPO-RATOR MOTOR		COM-PRESSOR		CON-DENSER MOTOR		CKT 1		CKT 2		CKT 1		CKT 2	
		240V	208V	240V	208V	240V	208V	AMPS	HP	RLA	LRA	AMPS	HP	240V	208V	240V	208V	240V	208V	240V	208V
EPE12	-03	3	2.25	10230	7670	13	11	2.3	1/4	4.6	25	2.3	1/4	26	24	0	0	30	25	0	0
	-05	4.5	3.38	15350	11530	19	16	2.3	1/4	4.6	25	2.3	1/4	34	31	0	0	35	35	0	0
EPE18	-03	3	2.25	10230	7670	13	11	2.8	1/3	7.6	36	2.8	1/3	30	28	0	0	35	30	0	0
	-05	5	3.75	17060	12790	21	18	2.8	1/3	7.6	36	2.8	1/3	41	37	0	0	45	40	0	0
	-07	7	5.25	23880	17910	29	25	2.8	1/3	7.6	36	2.8	1/3	51	46	0	0	55	50	0	0
	-10	9.5	7.125	32410	24310	40	34	2.8	1/3	7.6	36	2.8	1/3	15	15	49	43	15	15	50	45
EPE24	-05	5	3.75	17060	12790	21	18	2.8	1/3	10.2	58	2.8	1/3	44	41	0	0	45	45	0	0
	-07	7	5.25	23880	17910	29	25	2.8	1/3	10.2	58	2.8	1/3	55	50	0	0	55	50	0	0
	-10	9.5	7.125	32410	24310	40	34	2.8	1/3	10.2	58	2.8	1/3	18	18	49	43	25	25	50	45
EPE30	-05	5	3.75	17060	12790	21	18	4.1	1/2	12.8	77	2.8	1/3	49	45	0	0	55	50	0	0
	-07	7	5.25	23880	17910	29	25	4.1	1/2	12.8	77	2.8	1/3	59	54	0	0	60	55	0	0
	-10	9.5	7.125	32410	24310	40	34	4.1	1/2	12.8	77	2.8	1/3	23	23	49	43	30	30	50	45

**NOTE:**

Size 12 models require 1 electrical circuit  
 Size 18, 24 & 30 models require 2 electrical circuits for 10kW electric heat only

\*Circuits 1 and 2 require separate sets of power wires connected to the unit, each backed by an independent circuit breaker.

Size 12 models circuit 1 powers all components  
 Size 18, 24 & 30 models, circuit 1 powers compressor, condenser fan and evaporator motor. Circuit 2 powers both stages of electric heat

Refer to wiring diagrams In the EPE IOM for additional details  
 Wire size should be determined in accordance with National Electric Codes  
 Unit are rated for 208/240V, but MOP, MCA values are calculated at 208/240V

- RLA – Rated Load Amps
- LRA – Locked Rotor Amps
- FLA – Full Load Amps
- HP – Horsepower

# FRESH-PAK HP

## SPACE CONSTRAINED HEAT PUMP

### RATED COOLING & HEATING PERFORMANCE

FRESH-PAK HP COOLING & HEATING PERFORMANCE										
Model	Rated Airflow SCFM CFM	Cooling Capacity (AFull) 95°F, BTUH	EER2 (AFull) 95°F EER2	SEER2	Heating Capacity (H1Full) 47°F BTUH	Heating Capacity (H3Full) 17°F, BTUH	HSPF2	Heating Capacity (H4Full) 5°F, BTUH	COP 5°F	HSPF2 Region 5
EPE12***E	400	11200	10.0	11.9	10000	5500	6.3	4000	1.6	5.4
EPE18***E	650	18000	10.0	11.9	15800	9500	6.3	6500	1.6	5.4
EPE24***E	750	23000	9.5	11.9	21200	13500	6.3	11500	1.8	5.4
EPE30***E	950	28000	9.5	11.9	26800	18000	6.3	14500	1.9	5.4

(1) Tested at 95°F DB/75°F WB outdoor and 80°F DB/67°F WB indoor

(2) Tested at 47°F DB outdoor

### EXTENDED HEATING PERFORMANCE

#### HEAT PUMP ONLY

HEAT PUMP EXTENDED DATA, COMPRESSOR HEATING													
Model	Airflow	47/43			35/33			17/15			5/0		
		Net Capacity	Power Input	Outlet Dry Bulb	Net Capacity	Power Input	Outlet Dry Bulb	Net Capacity	Power Input	Outlet Dry Bulb	Net Capacity	Power Input	Outlet Dry Bulb
	SCFM	BTUH	kW	°F	BTUH	kW	°F	BTUH	kW	°F	BTUH	kW	°F
EPE122**E0DCF0LFA	390	10000	0.88	93	7000	0.85	90	5500	0.81	83	4100	0.78	79
EPE182**E0DCF0LFA	600	15800	1.40	94	12800	1.35	90	9500	1.32	84	6500	1.30	80
EPE242**E0DCF0LFA	800	21200	1.93	95	16600	1.90	90	13500	1.82	85	11500	1.80	82
EPE302**E0DCF0LFA	900	26800	2.46	97	22200	2.37	93	18000	2.3	88	15010	2.25	84

**NOTE:**

Performance data is based on nominal CFM and 70°F indoor dry bulb

\*May experience some loss in capacity.

\*This data is to be used as reference values only and does not constitute a rating or a guarantee that the installed system will perform as indicated.

# FRESH-PAK HP

## SPACE CONSTRAINED HEAT PUMP

### COMBINED EXTENDED HEATING PERFORMANCE

#### HEAT PUMP & ELECTRIC HEAT

HEAT PUMP EXTENDED DATA WITH ELECTRIC HEAT									
Model	Heater Size, 240V	47/43				35/33			
		240V		208V		240V		208V	
	kW	Net Capacity	Power Input	Net Capacity	Power Input	Net Capacity	Power Input	Net Capacity	Power Input
		BTUH	kW	BTUH	kW	BTUH	kW	BTUH	kW
EPE12203E0DCF0LFA	3	20230	3.88	17670	3.13	17230	3.85	14670	3.10
EPE12205E0DCF0LFA	5	27060	5.88	22790	4.63	24060	5.85	19790	4.60
EPE18205E0DCF0LFA	5	32860	6.40	28590	5.15	29860	6.35	25590	5.10
EPE18207E0DCF0LFA	7	39680	8.40	33710	6.65	36680	8.35	30710	6.60
EPE18210E0DCF0LFA	10	49920	11.40	41390	8.90	46920	11.35	38390	8.85
EPE24205E0DCF0LFA	5	38260	6.93	33990	5.68	33660	6.90	29390	5.65
EPE24207E0DCF0LFA	7	45080	8.93	39110	7.18	40480	8.90	34510	7.15
EPE24210E0DCF0LFA	10	55320	11.93	46790	9.43	50720	11.90	42190	9.40
EPE30205E0DCF0LFA	5	43860	7.46	39590	6.21	39260	7.37	34990	6.12
EPE30207E0DCF0LFA	7	50680	9.46	44710	7.71	46080	9.37	40110	7.62
EPE30210E0DCF0LFA	10	60920	12.46	52390	9.96	56320	12.37	47790	9.87

HEAT PUMP EXTENDED DATA WITH ELECTRIC HEAT									
Model	Heater Size, 240V	17/15				5/0			
		240V		208V		240V		208V	
	kW	Net Capacity	Power Input	Net Capacity	Power Input	Net Capacity	Power Input	Net Capacity	Power Input
		BTUH	kW	BTUH	kW	BTUH	kW	BTUH	kW
EPE12203E0DCF0LFA	3	15730	3.81	13170	3.06	14330	3.78	11770	3.03
EPE12205E0DCF0LFA	5	22560	5.81	18290	4.56	21160	5.78	16890	4.53
EPE18205E0DCF0LFA	5	26560	6.32	22290	5.07	23560	6.30	19290	5.05
EPE18207E0DCF0LFA	7	33380	8.32	27410	6.57	30380	8.30	24410	6.55
EPE18210E0DCF0LFA	10	43620	11.32	35090	8.82	40620	11.30	32090	8.80
EPE24205E0DCF0LFA	5	30560	6.82	26290	5.57	28560	6.80	24290	5.55
EPE24207E0DCF0LFA	7	37380	8.82	31410	7.07	35380	8.80	29410	7.05
EPE24210E0DCF0LFA	10	47620	11.82	39090	9.32	45620	11.80	37090	9.30
EPE30205E0DCF0LFA	5	35060	7.30	30790	6.05	32070	7.25	27800	6.00
EPE30207E0DCF0LFA	7	41880	9.30	35910	7.55	38890	9.25	32920	7.50
EPE30210E0DCF0LFA	10	52120	12.30	43590	9.80	49130	12.25	40600	9.75

**NOTE:**

Values based on nominal airflow at .3" in H<sub>2</sub>O, 70°F Inlet Air

\*May experience some loss in capacity.

\*This data is to be used as reference values only and does not constitute a rating or a guarantee that the installed system will perform as indicated.

# FRESH-PAK HP

## SPACE CONSTRAINED HEAT PUMP

### EXTENDED COOLING PERFORMANCE

FRESH-PAK HP – EXTENDED COOLING PERFORMANCE										
Model	Indoor Temp DB/WB	Outdoor Temperature °F								
		65.0			75.0			85.0		
		BTUH	S/T	kW	BTUH	S/T	kW	BTUH	S/T	kW
EPE12	75/57	11850	1.00	0.76	11450	1.00	0.86	10700	1.00	0.98
	75/63	12750	0.75	0.76	12150	0.77	0.86	11500	0.79	0.98
	80/67	13650	0.73	0.76	13000	0.74	0.86	12350	0.76	0.98
	85/72	14800	0.66	0.76	14100	0.68	0.86	13400	0.69	0.98
EPE18	75/57	18800	1.00	1.24	17600	1.00	1.36	16950	1.00	1.52
	75/63	20100	0.76	1.24	19100	0.77	1.36	18200	0.79	1.52
	80/67	21400	0.73	1.22	20400	0.74	1.36	19450	0.77	1.52
	85/72	23200	0.66	1.22	22150	0.68	1.36	21050	0.69	1.50
EPE24	75/57	22850	1.00	1.78	22100	1.00	1.96	21500	1.00	2.16
	75/63	25100	0.73	1.78	24000	0.74	1.96	22900	0.77	2.18
	80/67	26750	0.70	1.80	25600	0.72	1.98	24450	0.74	2.18
	85/72	28900	0.64	1.80	27700	0.66	1.98	26450	0.68	2.20
EPE30	75/57	29650	1.00	2.30	28450	1.00	2.50	27450	1.00	2.74
	75/63	32600	0.72	2.34	31250	0.73	2.54	29800	0.74	2.78
	80/67	34750	0.69	2.36	33250	0.70	2.58	31700	0.71	2.80
	85/72	37450	0.63	2.40	35850	0.63	2.62	34200	0.65	2.86

FRESH-PAK HP – EXTENDED COOLING PERFORMANCE										
Model	Indoor Temp DB/WB	Outdoor Temperature °F								
		95.0			105.0			115.0		
		BTUH	S/T	kW	BTUH	S/T	kW	BTUH	S/T	kW
EPE12	75/57	10000	1.00	1.06	9500	1.00	1.2	9000	1.00	1.38
	75/63	10600	0.81	1.06	10050	0.83	1.2	9400	0.87	1.38
	80/67	11400	0.79	1.06	10700	0.81	1.2	10050	0.84	1.38
	85/72	12300	0.71	1.04	11600	0.73	1.2	10900	0.76	1.36
EPE18	75/57	16050	1.00	1.64	15300	1.00	1.84	14500	1.00	2.08
	75/63	17000	0.82	1.64	16100	0.85	1.84	15100	0.87	2.08
	80/67	18200	0.79	1.64	17150	0.82	1.84	16150	0.84	2.08
	85/72	19700	0.72	1.64	18600	0.74	1.84	17500	0.77	2.08
EPE24	75/57	19900	1.00	2.40	19050	1.00	2.66	18100	1.00	2.96
	75/63	21650	0.79	2.40	20400	0.80	2.68	19150	0.82	2.96
	80/67	22950	0.75	2.42	21750	0.78	2.68	20500	0.80	2.98
	85/72	24800	0.69	2.42	23500	0.70	2.7	22150	0.72	2.98
EPE30	75/57	26350	1.00	3.02	24550	1.00	3.32	23500	1.00	3.66
	75/63	28000	0.76	3.06	26450	0.77	3.36	25100	0.80	3.70
	80/67	29750	0.73	3.10	28500	0.77	3.4	26800	0.77	3.72
	85/72	32300	0.68	3.14	30400	0.68	3.46	28850	0.70	3.78

**NOTE:**  
 \* Total power input of the unit  
 Performance data is simulated based on the rated value of each model and is calculated based on nominal CFM and .3 external static pressure  
 This data is to be used as reference values only and does not constitute a rating or a guarantee that the installed system will perform as indicated

# FRESH-PAK HP

## SPACE CONSTRAINED HEAT PUMP

### BLOWER PERFORMANCE

FRESH-PAK HP – BLOWER PERFORMANCE												
MODEL	Motor Tap	Motor Speed	IWC STATIC PRESSURE									
			0.10		0.20		0.30		0.40		0.50	
			SCFM	W	SCFM	W	SCFM	W	SCFM	W	SCFM	W
EPE12203	1	T1	284	22	271	30	255	36	237	41	219	45
	2	T2H	446	73	433	81	417	87	399	41	381	95
	3	T3	505	98	492	106	476	112	458	41	440	121
	4	T4C	477	86	464	93	448	100	430	41	412	108
EPE12205	1	T1	284	22	271	30	255	36	237	41	219	45
	2	T2H	477	86	464	93	448	100	430	41	412	108
	3	T3	505	98	492	106	476	112	458	41	440	121
	4	T4C	477	86	464	93	448	100	430	41	412	108
EPE182205	1	T1	540	74	500	75	474	77	441	77	407	74
	2	T2H	703	126	663	126	637	129	604	129	570	126
	3	T3	832	189	792	189	766	191	734	191	700	189
	4	T4C	749	146	709	146	683	149	651	149	617	146
	5	T5	901	233	861	234	835	236	803	236	769	233
EPE182207	1	T1	540	74	500	75	474	77	441	77	407	74
	2	T2H	749	146	709	146	683	149	651	149	617	146
	3	T3	792	167	752	167	726	170	694	170	660	167
	4	T4C	832	189	792	189	766	191	734	191	700	189
	5	T5	901	233	861	234	835	236	803	236	769	233
EPE182210	1	T1	407	46	367	46	341	48	308	48	274	46
	2	T2H	792	167	752	167	726	170	694	170	660	167
	3	T3	956	274	916	275	890	277	857	277	823	275
	4	T4C	832	189	792	189	766	191	734	191	700	189
	5	T5	901	233	861	234	835	236	803	236	769	233

C – Factory Default Cooling and Heat Pump Airflow

H – Factory Default Electric Heat Airflow

T2 & T3 are reserved for Electric Heat operation only

T4 & T5 are reserved for Cooling and Heat pump operation only

Blower performance data based on a dry coil at 70°F DB EAT with a standard 1" clean air filter

# FRESH-PAK HP

## SPACE CONSTRAINED HEAT PUMP

### BLOWER PERFORMANCE (CONT'D)

FRESH-PAK HP – BLOWER PERFORMANCE (CONT'D)												
MODEL	Motor Tap	Motor Speed	IWC STATIC PRESSURE									
			0.10		0.20		0.30		0.40		0.50	
			SCFM	W	SCFM	W	SCFM	W	SCFM	W	SCFM	W
EPE24205	1	T1	749	146	709	146	683	149	651	149	617	146
	2	T2H	832	189	792	189	766	191	734	191	700	189
	3	T3	956	274	916	275	890	277	857	277	823	275
	4	T4CL	663	111	623	111	597	114	564	114	530	111
	5	T5CH	907	237	867	238	841	240	809	240	775	238
EPE24207	1	T1	749	146	709	146	683	149	651	149	617	146
	2	T2H	868	211	828	211	802	214	770	214	736	211
	3	T3	832	189	792	189	766	191	734	191	700	189
	4	T4CL	663	111	623	111	597	114	564	114	530	111
	5	T5CH	907	237	867	238	841	240	809	240	775	238
EPE24210	1	T1	749	146	709	146	683	149	651	149	617	146
	2	T2H	907	237	867	238	841	240	809	240	775	238
	3	T3	832	189	792	189	766	191	734	191	700	189
	4	T4CL	663	111	623	111	597	114	564	114	530	111
	5	T5CH	931	255	891	255	865	257	832	257	798	255
EPE30205	1	T1	729	117	656	117	615	111	584	106	541	96
	2	T2H	873	215	843	215	802	209	771	204	728	194
	3	T3	961	274	931	273	891	267	860	262	816	252
	4	T4CL	981	287	950	287	910	281	879	276	836	266
	5	T5CH	1014	310	984	310	943	304	912	299	869	289
EPE30207	1	T1	729	117	656	117	615	111	584	106	541	96
	2	T2H	922	247	891	246	851	240	820	235	776	226
	3	T3	961	274	931	273	891	267	860	262	816	252
	4	T4CL	981	287	950	287	910	281	879	276	836	266
	5	T5CH	1014	310	984	310	943	304	912	299	869	289
EPE30210	1	T1	791	141	710	141	670	135	639	130	595	120
	2	T2H	992	295	962	295	921	289	890	284	847	274
	3	T3	961	274	931	273	891	267	860	262	816	252
	4	T4CL	981	287	950	287	910	281	879	276	836	266
	5	T5CH	1014	310	984	310	943	304	912	299	869	289

C – Factory Default Cooling and Heat Pump Airflow

H – Factory Default Electric Heat Airflow

T2 & T3 are reserved for Electric Heat operation only

T4 & T5 are reserved for Cooling and Heat pump operation only

Blower performance data based on a dry coil at 70°F DB EAT with a standard 1" clean air filter

# FRESH-PAK HP

SPACE CONSTRAINED HEAT PUMP

## ERV FAN PERFORMANCE

ERV FAN CURVE – AIR FLOW AT 60HZ

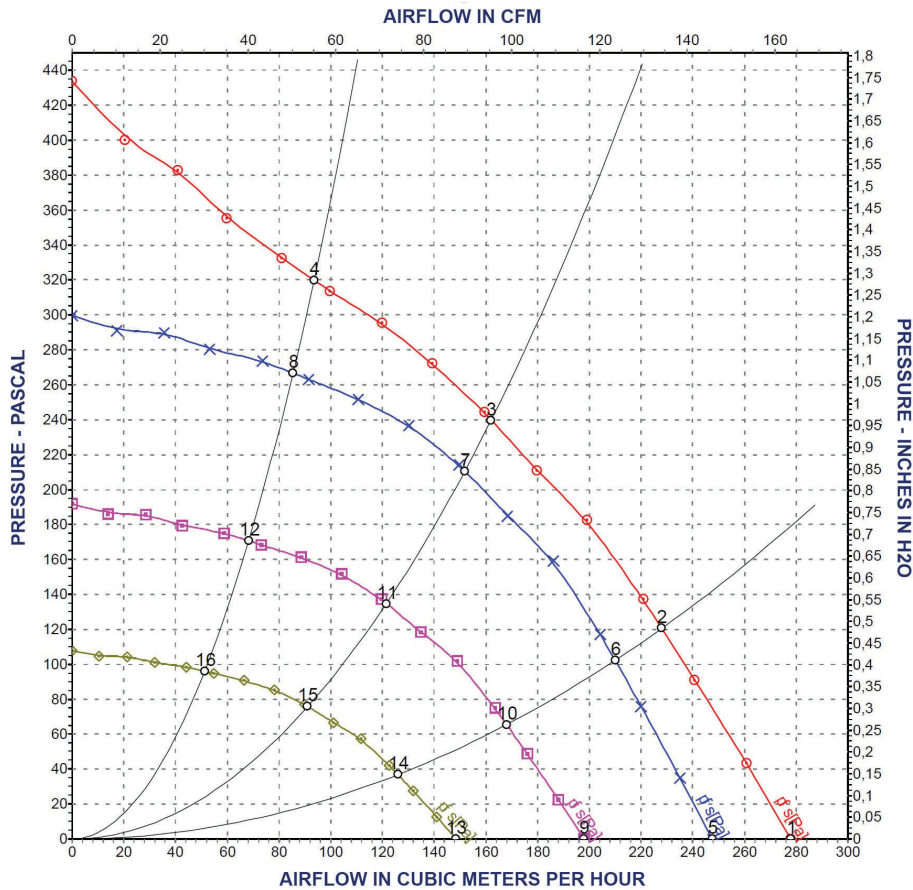

	Voltage	Frequency Hz	Speed (Rev/min)	Power (Watts)	Current (Amps)	Airflow (m <sup>3</sup> /h)	Pressure (Pa)	Airflow (CFM)	Pressure (IN H2O)
1	230	60	3930	24	0.23	280	0	165	0.00
2	230	60	3800	26	0.26	230	120	136	0.48
3	230	60	3770	27	0.27	160	240	95	0.96
4	230	60	3835	26	0.25	95	320	56	1.28
5	230	60	3500	17	0.16	250	0	148	0.00
6	230	60	3500	20	0.2	210	102	124	0.41
7	230	60	3500	22	0.22	150	211	89	0.85
8	230	60	3500	19	0.19	85	267	51	1.07
9	230	60	2800	8.5	0.08	200	0	118	0.00
10	230	60	2800	10	0.1	170	66	101	0.26
11	230	60	2800	11	0.11	120	135	71	0.54
12	230	60	2800	9.9	0.1	70	171	42	0.69
13	230	60	2100	3.6	0.04	150	0	89	0.00
14	230	60	2100	4.4	0.04	125	37	74	0.15
15	230	60	2100	4.8	0.05	90	76	53	0.31
16	230	60	2100	4.2	0.04	50	96	30	0.39

# FRESH-PAK HP

SPACE CONSTRAINED HEAT PUMP

## ERV FAN PERFORMANCE SUMMER

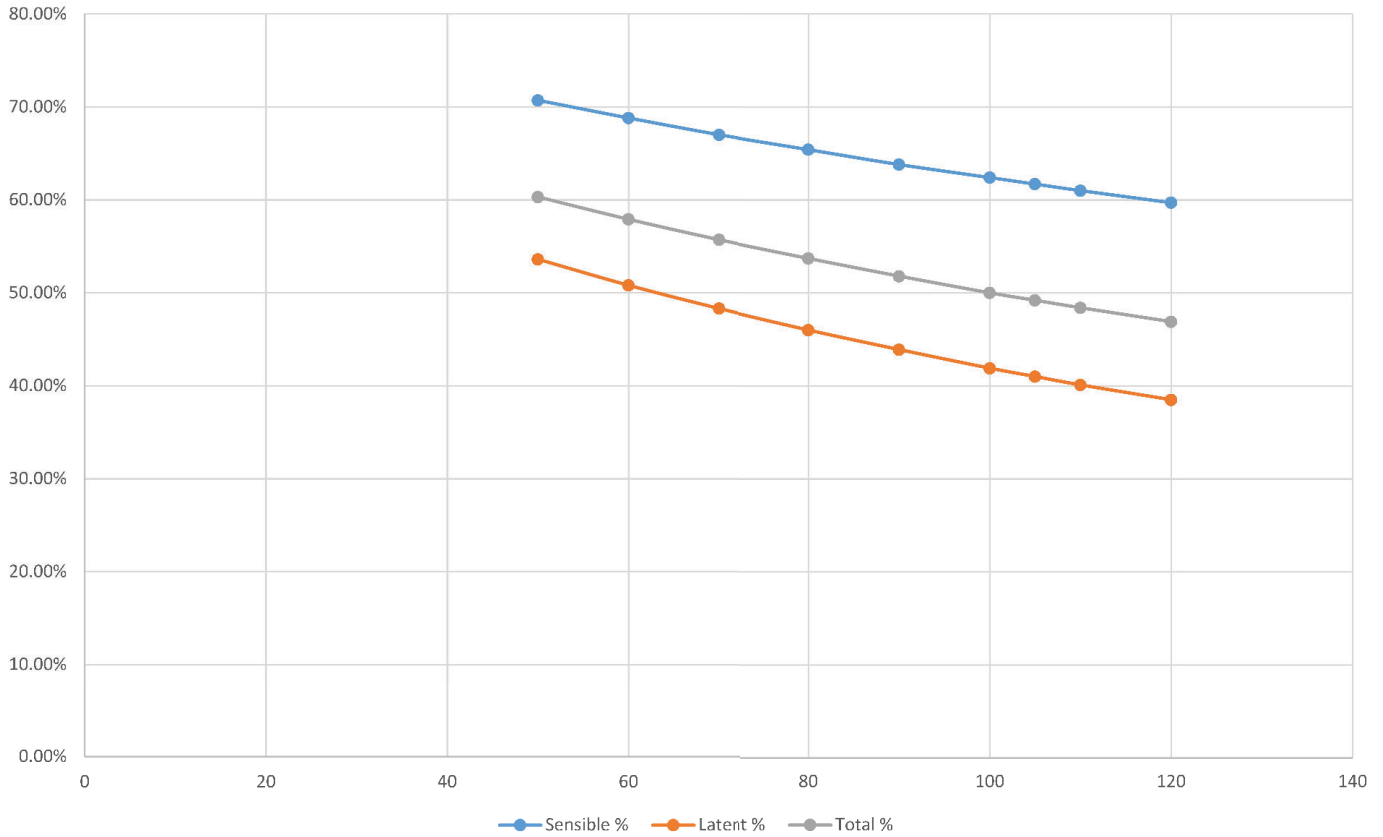

OUTDOOR		RETURN	
db	rh	db	rh
95	46.5%	75	51.17%



CFM	SENSIBLE %	LATENT %	TOTAL %
50	70.70%	53.60%	60.30%
60	68.80%	50.80%	57.90%
70	67.00%	48.30%	55.70%
80	65.40%	46.00%	53.70%
90	63.80%	43.90%	51.80%
100	62.40%	41.90%	50.00%
105	61.70%	41.00%	49.20%
110	61.00%	40.10%	48.40%
120	59.70%	38.50%	46.90%

# FRESH-PAK HP

## SPACE CONSTRAINED HEAT PUMP

### ERV FAN PERFORMANCE WINTER

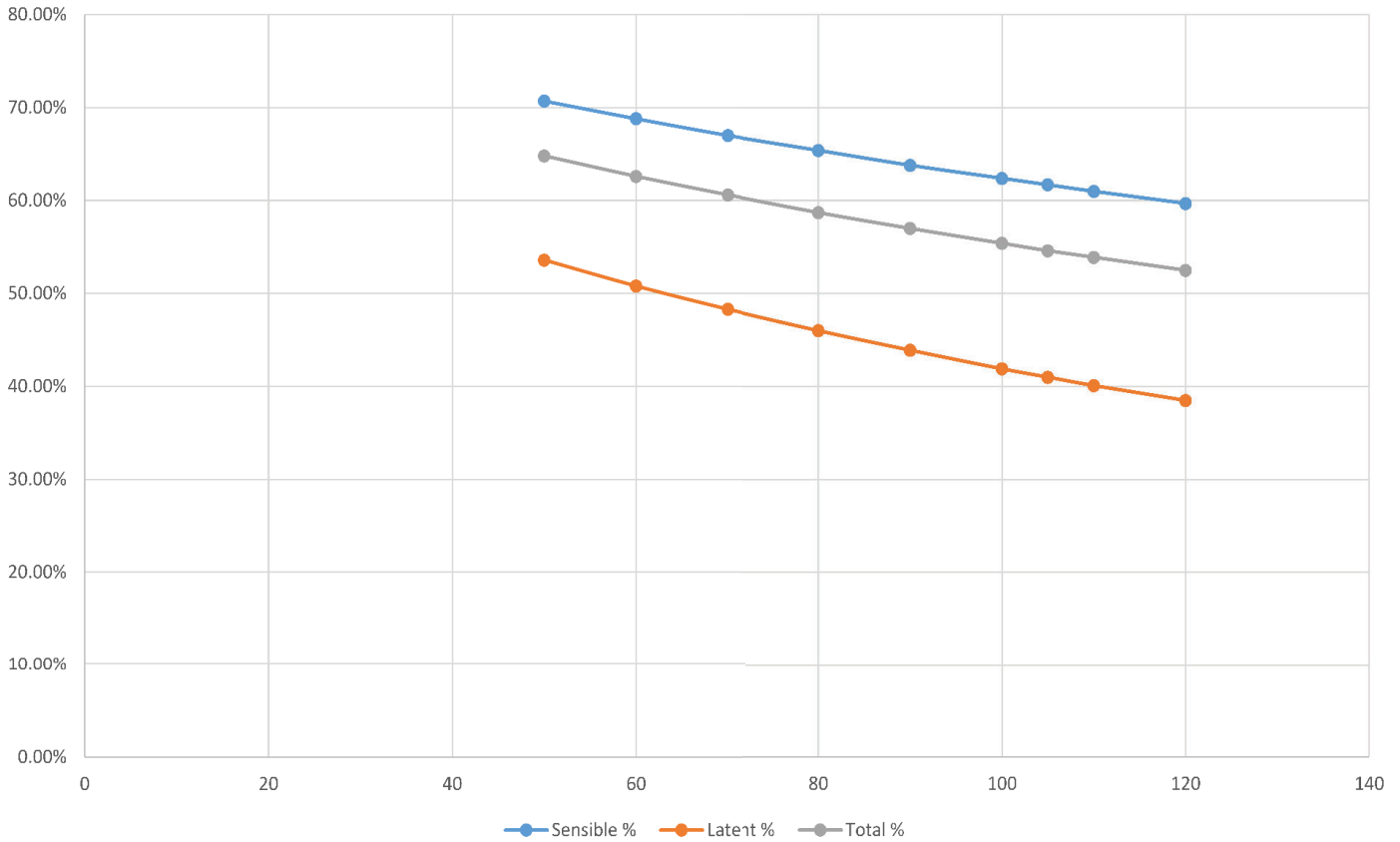

OUTDOOR		RETURN	
db	rh	db	rh
35	81.69%	70	47.88%



CFM	SENSIBLE %	LATENT %	TOTAL %
50	70.70%	53.60%	64.80%
60	68.80%	50.80%	62.60%
70	67.00%	48.30%	60.60%
80	65.40%	46.00%	58.70%
90	63.80%	43.90%	57.00%
100	62.40%	41.90%	55.40%
105	61.70%	41.00%	54.60%
110	61.00%	40.10%	53.90%
120	59.70%	38.50%	52.50%



*AMERICAN-MADE. FAMILY OWNED.*



FIRST CO.  
P.O. BOX 270969 - DALLAS, TEXAS 75227  
PH. (214) 388-5751 | FAX (214) 388-2255  
[WWW.FIRSTCO.COM](http://WWW.FIRSTCO.COM)

**MARCH 2026**