



ecoseries
COOL-PAK

*Space Constrained Air Conditioner
with Electric Heat*

3/4 - 2.5 Tons

3 - 10 kW Electric Heat

11.7 SEER2

R454B



NOMENCLATURE

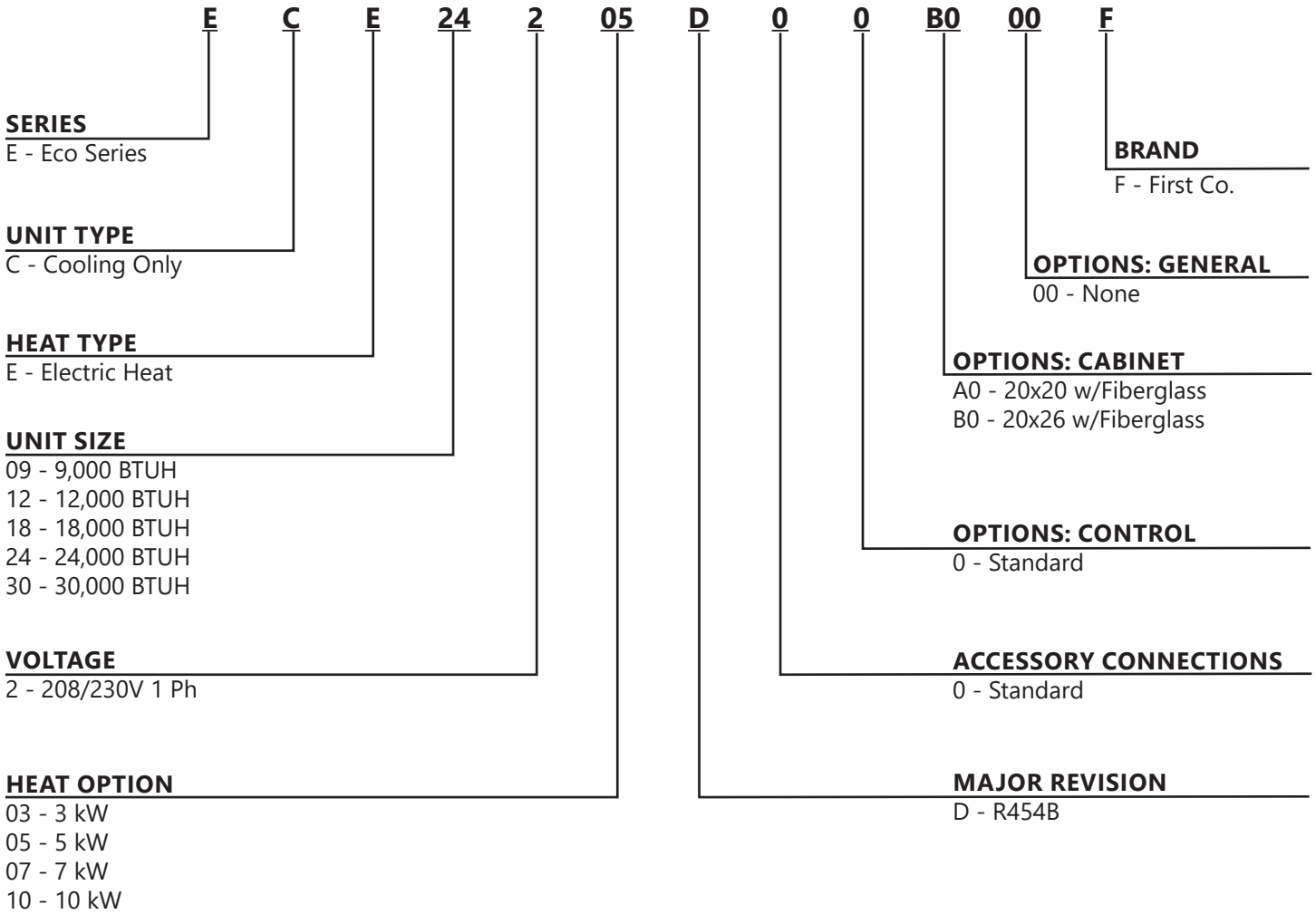

ECO SERIES COOL-PAK

SPACE CONSTRAINED AIR CONDITIONER

PRODUCT DESCRIPTION

- Space constrained electric cooling and electric heating
- Pre-wired and pre-charged with R-454B refrigerant, capable of delivering conditioned air to multiple rooms.
- Easily installs into a closet or mechanical room on an exterior wall, utilizing a minimal amount of floor space.
- Controlled by a standard low voltage thermostat with high and low temperature limits.

APPLICATIONS

Hospitality, Apartments/Condominiums, Assisted Living/Memory Care, Student Housing, Senior Living and Modular/Prefabricated Buildings.

STANDARD FEATURES

- Shipped ready for top supply and front return (with optional ducted return)
- Insulated compartment to improve cooling performance, reduce noise, and prevent sweating
- ECM indoor blower & outdoor fan motor to provide precise airflow selection and improve system efficiency
- High efficiency single stage scroll and rotary compressors with double isolated compressor mount to reduce compressor noise and vibration. *(Two Stage Scroll available for reduced cabinet size 2-ton unit.)*
- Larger evaporator coil with low face velocity for improved cooling performance
- Drain pan with corrosion resistant coating
- Thermal expansion valve (TXV) to optimize performance
- High pressure switch protection
- Electric heat with automatic reset limit switch and non-resettable fuse link
- Filter brackets and disposable filter shipped with unit for field installation; no tool needed to replace filter.
- Multi-function microprocessor control board
- Make-up air vent when fully opened allows up to 50 CFM of ventilation air to be introduced into the closet
- Units charged with over 4lbs of refrigerant have factory installed leak mitigation sensors

SERVICEABILITY FEATURES

- Easy access for in-place service of most components
- All electrical components and control boards are serviceable from front of the unit

LIMITED WARRANTY

5 Years Compressor, 5 Years parts

REQUIRED ACCESSORIES

- Weight bearing wall sleeves for various wall thicknesses from 5" to 20" shipped with weather and debris guard
- Wall sleeves have primary condensate drain connection with secondary overflow to building exterior
- Flush type aluminum louver with finish and paint options
- Standard low voltage thermostat with high and low temperature limits

ECO SERIES COOL-PAK

SPACE CONSTRAINED AIR CONDITIONER

REQUIRED ACCESSORIES

Flush type aluminum louver with finish and paint options.

STANDARD PAINT COLORS

 <p>SLATE BLUE (LF01)</p>	 <p>MEDIUM BRONZE (LF02)</p>	 <p>SANDSTONE (LF03)</p>
 <p>LIGHT GRAY (LF04)</p>	 <p>CHARCOAL (LF05)</p>	 <p>BONE WHITE (LF06)</p>
 <p>WESTERN TAN (LF07)</p>	 <p>ARCHITECTURAL BRONZE (LF08)</p>	 <p>REGAL BLUE (LF09)</p>
 <p>FOREST GREEN (LF10)</p>	 <p>SURREY BEIGE (LF11)</p>	 <p>ROYAL BROWN (LF12)</p>
 <p>BARN RED (LF13)</p>	 <p>BURGUNDY (LF14)</p>	 <p>CLAY (LF15)</p>
 <p>ALMOND (LF16)</p>	 <p>COASTAL WHITE (LF17)</p>	 <p>VISTA GREEN (LF18)</p>
 <p>BLACK (LF19)</p>	 <p>GLOSS BLACK (LF20)</p>	 <p>CAMPUS GREEN (LF21)</p>

Custom color options available

ECO SERIES COOL-PAK

SPACE CONSTRAINED AIR CONDITIONER

FILTER RACK

Filter Brackets and a disposable filter ship with each unit to be field installed over the evaporator coil.

NOTE: Do not use filters which will cause the total external static pressure including ducts, louvers, registers, and filters to exceed 0.5 in. H₂O.

MULTI-FUNCTION MICROPROCESSOR CONTROL BOARD

Evaporator coil low temperature protection – guards against a low temperature condition that could result in ice buildup on the coil or reduced air flow, a temperature sensor attached to the coil will de-energize the unit. The sensor will re-energize the unit when the coil warms up to an acceptable temperature.

Random restart – When power is turned on after a power outage, a built-in random restart delay of 3-4 minutes prevents all compressors from restarting simultaneously.

Compressor restart delay – This delay ensures that system pressures are allowed to equalize before a compressor restart, which extends compressor life.

Fan delay – A fan delay allows the evaporator blower to continue running for up to 45 seconds after the thermostat is satisfied, which maximizes cooling performance.

Low voltage fuse protection - Disconnects the live circuit when the current exceeds a predetermined value.

ECO SERIES COOL-PAK

SPACE CONSTRAINED AIR CONDITIONER

VENTILATION AIR

One end of a 3" aluminum vent pipe is connected to the condenser venturi and the other end is connected to the side of the cabinet. A mesh screen and a metal plate on the side of the cabinet covers the opening of the vent pipe.

Up to 50 CFM of ventilation air is introduced into the equipment closet by removing the metal cover plate. The ventilation air mixes with the return air and is then pulled through the evaporator coil and into the supply duct. The cover plate can be reinstalled to partially close the ventilation air opening if less than 50 CFM is desired. An external source of negative pressure (i.e. a bathroom fan) could be used to introduce more than 50 CFM of ventilation air. Consult with factory for further details.

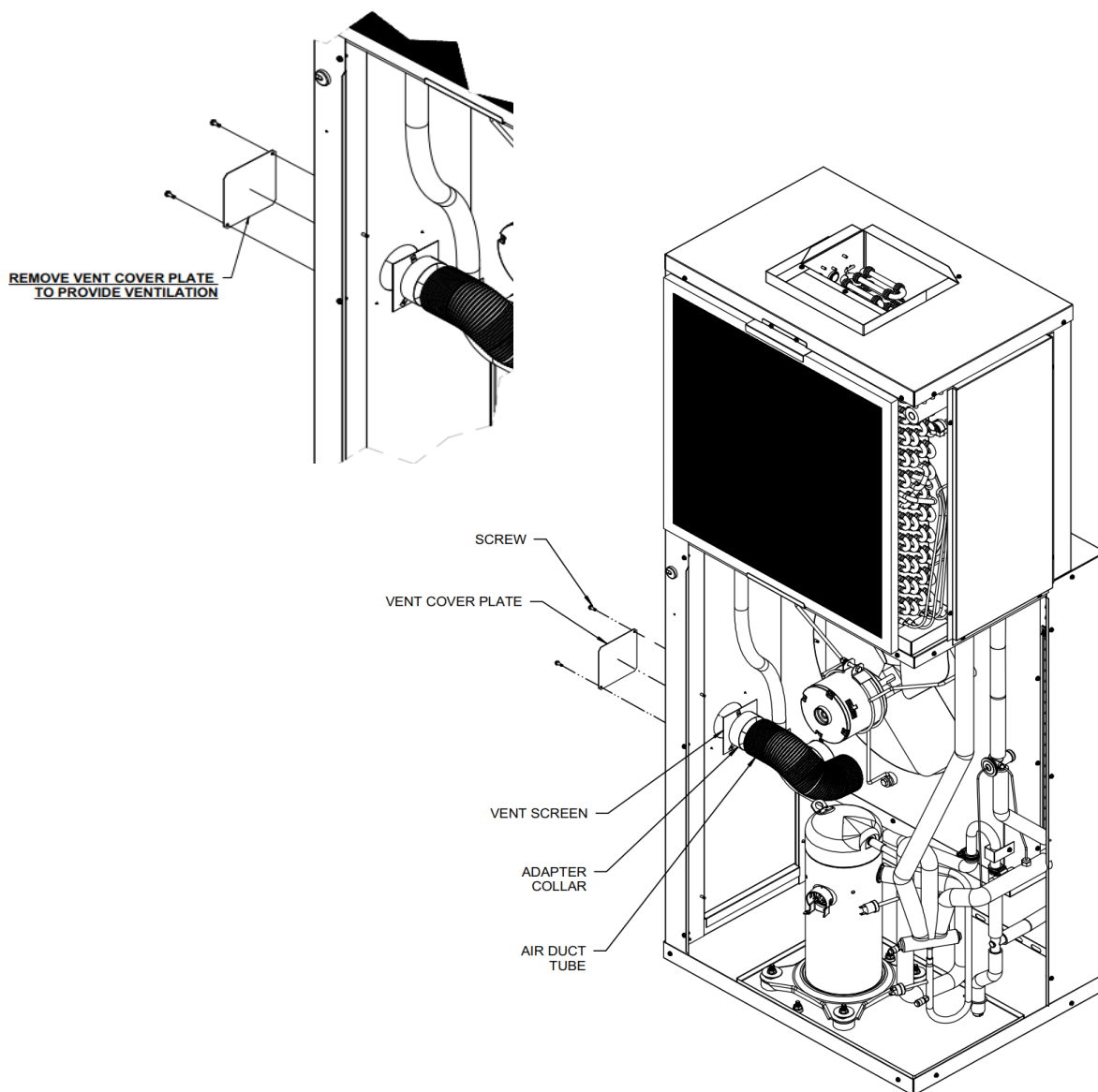

ECO SERIES COOL-PAK

SPACE CONSTRAINED AIR CONDITIONER

CONDENSATE SYSTEM

Primary Condensate

Factory installed drain line connects the evaporator drain pan to a vertical pipe connection in the unit base pan. Evaporator condensate is delivered from the unit to a catch tray in the wall sleeve and exits the sleeve through the 3/4" male NPT fitting. This design allows the plumber to completely pipe the drain to a condensate riser during the rough-in stage, thus eliminating condensate connection problems usually encountered when trying to connect the HVAC drain to the riser after the HVAC unit is installed in the closet. This feature also allows the unit to be removed for service without disconnecting the condensate piping. This configuration does not require any additional closet space to make the drain connection, as do some competitive products.

Secondary Condensate Overflow

If for any reason the primary condensate riser becomes clogged, water will fill the catch tray and then be diverted through the sleeve to the exterior of the building, rather than be allowed to overflow into the closet or living area. Rain water entering the sleeve is automatically diverted to the 3/4" condensate drain.

REQUIRED ACCESSORIES: WALL SLEEVES

- Provided for installation during rough-in and when ready the unit is simply slid into the wall sleeve and connected to the ductwork and electrical.
- Weight bearing sleeve that supports the entire weight of the unit and provides a weather tight seal against wind and water infiltration.
- Four wall sleeve depths are available to accommodate wall thickness from 5" to 20".
- Includes a weather guard to cover the sleeve opening and a debris guard to cover wall sleeve base and drain during construction.

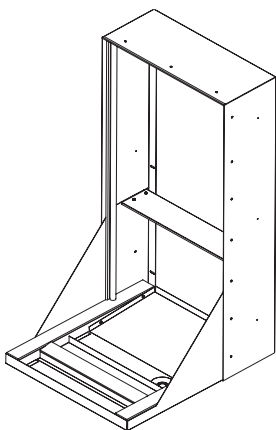

Standard Sleeve
for 3/4 - 2 tons

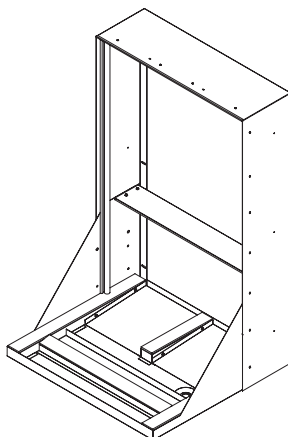

Standard Sleeve
for 2.0 - 2.5 tons

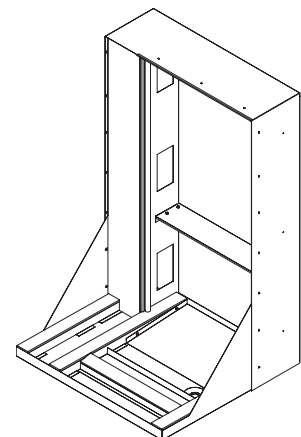

Oversized Sleeve
for 3/4 - 2 tons
to provide uniform
exterior appearance

ECO SERIES COOL-PAK



SPACE CONSTRAINED AIR CONDITIONER

ACCESSORIES

SLEEVE AND LOUVER ACCESSORIES						
ACCESSORY	DESCRIPTION	DIMENSIONS (H x W x D)	STANDARD SLEEVES		SHIP WT. (EA) Lbs.	
			REAR INSTALL ¹	SIDE INSTALL ²	REAR ⁵	SIDE ⁵
SMALL CABINET "A" WALL SLEEVES	For 5" - 8" thick walls	43-3/4 x 21-3/8 x 26	936-1B	936-11B	59	64
	For 8" - 12" thick walls	43-3/4 x 21-3/8 x 30	936-2B	936-12B	63	73
	For 12" - 15" thick walls	43-3/4 x 21-3/8 x 33	936-3B	936-13B	68	73
	For 15" - 20" thick walls	43-3/4 x 21-3/8 x 38	936-4B	936-14B	75	80
LARGE CABINET "B" WALL SLEEVES	For 5" - 8" thick walls	43-3/4 x 27-3/8 x 26	985-1B	985-11B	63	68
	For 8" - 12" thick walls	43-3/4 x 27-3/8 x 30	985-2B	985-12B	68	73
	For 12" - 15" thick walls	43-3/4 x 27-3/8 x 33	985-3B	985-13B	75	80
	For 15" - 20" thick walls	43-3/4 x 27-3/8 x 38	985-4B	985-14B	79	84
SMALL CABINET "A" LARGE WALL SLEEVES WITH BLOCKOFF	For 5" - 8" thick walls	43-3/4 x 27-3/8 x 26	986-1B	986-11B	63	68
	For 8" - 12" thick walls	43-3/4 x 27-3/8 x 30	986-2B	986-12B	68	73
	For 12" - 15" thick walls	43-3/4 x 27-3/8 x 33	986-3B	986-13B	75	80
	For 15" - 20" thick walls	43-3/4 x 27-3/8 x 38	986-4B	986-14B	79	84
STANDARD LOUVERS CABINET "A" WALL SLEEVES	Custom Painting	44x22	G205S		12	
	For Field Painting	44x22	G205PPA		12	
	Anodized Aluminum	44x22	G205A		12	
STANDARD LOUVERS CABINET "B" LARGE WALL SLEEVES	Custom Painting	44x28	G216S		18	
	For Field Painting	44x28	G216PPA		18	
	Anodized Aluminum	44x28	G216A		18	

NOTES:

1. Rear install application provides better access to the unit and is recommended over side install wherever possible.
2. Side install application requires different closet size and configuration. Contact factory for further information.
3. Wind resistant sleeves require the usage of a wind resistant louver.
4. S indicates custom color, to be provided by customer. Minimum order quantity is 15 per color, if less than 15, set up fees will be applied.
5. All wall sleeves are shipped two (2) per carton, fully assembled.

THERMOSTATS			
Heat Pump (24V) Digital w/emergency heat cool - off - heat, auto - on w/limits-(6-wire)	4 x 5 (Horizontal)	T1220NC	
Programmable (5-2) St. Cool/Ht. Pump (24V) cool-off-heat, auto-on w/em. Ht. & limits (6-wire)	4 x 5 (Horizontal)	T2220NC	
Straight Cool or Heat Pump (24V) Digital Occupancy Sensor	4.3 x 5.7 (Horizontal)	T8532	

ECO SERIES COOL-PAK

SPACE CONSTRAINED AIR CONDITIONER

OPTIONAL ACCESSORIES (FIELD INSTALLED)						
COMPONENT	DESCRIPTION	DIMENSIONS (H X W)		PART NUMBER	SHIPPING WEIGHT	EQUIPPED WITH FILTER
		FRAME	OPENING			
ACCESS/RETURN AIR PANEL (3)(4)	LOUVERED (1)	87 X 31	84 X 28	931-11	55	20 x 24 x 1
	NON-LOUVERED (2)	87 X 31	84 X 28	931-12		NO
	LOUVERED (1)	82 X 31	79 X 28	931-13		20 x 24 x 1
	NON-LOUVERED (2)	82 X 31	79 X 28	931-14		NO
ACCESS/RETURN AIR PANEL (3)(4)	LOUVERED (1)	87 X 37	84 X 34	931-15	55	20 x 24 x 1
	NON-LOUVERED (2)	87 X 37	84 X 34	931-16		NO
	LOUVERED (1)	82 X 37	79 X 34	931-17		20 x 24 x 1
	NON-LOUVERED (2)	82 X 37	79 X 34	931-18		NO
9-24A INSULATION KIT	5/8" DUCTBOARD	N/A	N/A	91K01	---	---
24B-30 INSULATION KIT				91K02	---	---
9-24A INSULATION KIT	5/8" DUCTBOARD	N/A	N/A	91K01	---	---
24B-30 INSULATION KIT				91K02	---	---

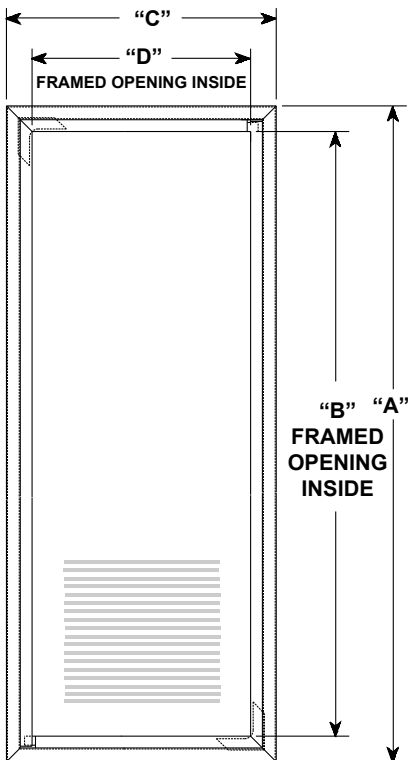

* For rear installation use with size 24 or 30

NOTE: A solid door or panel with a side wall return air louver will result in lower sound levels.

NOTES:

- (1) Includes 18 x 24 x 1 or 20 x 24 x 1 filter.
- (2) Requires external return air louver and unit mount filter.
- (3) Both panels are insulated for sound reduction and have tamperproof screws.
- (4) Panels are shipped ten per carton.

PART NO.	"A"	"B"	"C"	"D"
931-11(12)	87.00	84.00	31.00	28.00
931-13(14)	82.00	79.00	31.00	28.00
*931-15(16)	87.00	84.00	37.00	34.00
*931-17(18)	82.00	79.00	37.00	34.00

ECO SERIES COOL-PAK

SPACE CONSTRAINED AIR CONDITIONER

PHYSICAL DATA

UNIT DIMENSIONS

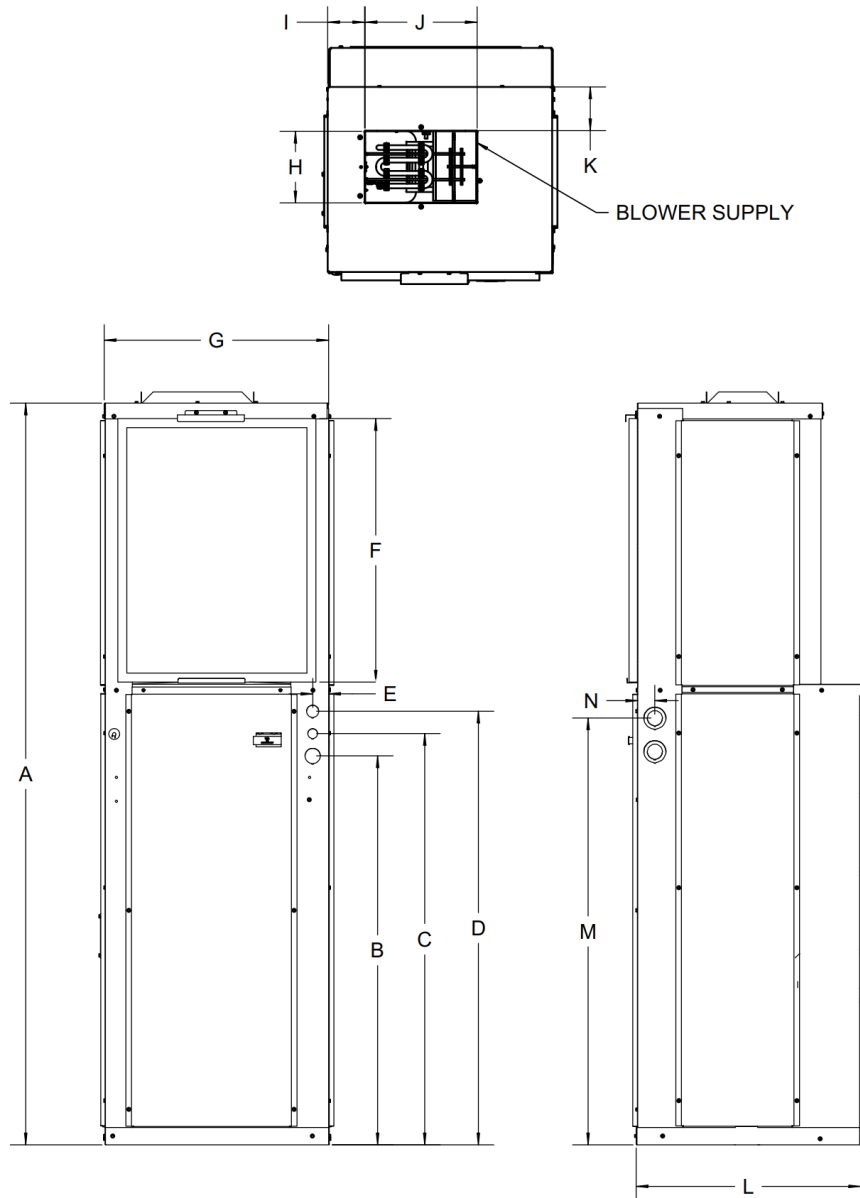

MODEL NUMBER	A	B	C	D	E	F	G	H	I	J	K	L	M	N
	CABINET DIMENSIONS							SUPPLY CONNECTIONS						
ECE09***A	66.5	34.9	36.9	38.9	1.4	23.6	20.9	6.4	3.3	10.0	3.9	20.1	38.2	1.6
ECE12***A	66.5	34.9	36.9	38.9	1.4	23.6	20.9	6.4	3.3	10.0	3.9	20.1	38.2	1.6
ECE18***A	66.5	34.9	36.9	38.9	1.4	23.6	20.9	6.4	3.3	10.0	3.9	20.1	38.2	1.6
ECE24***A	66.5	34.9	36.9	38.9	1.4	23.6	20.9	6.4	3.3	10.0	3.9	20.1	38.2	1.6
ECE24***B	66.5	34.9	36.9	38.9	1.4	23.7	26.9	10.0	7.9	10.0	3.9	20.1	38.2	1.6
ECE30***B	66.5	34.9	36.9	38.9	1.4	23.7	26.9	10.0	7.9	10.0	3.9	20.1	38.2	1.6

NOTE:

24A is for the smaller cabinet.

ECO SERIES COOL-PAK

SPACE CONSTRAINED AIR CONDITIONER

BLOWER PERFORMANCE

MODEL	MOTOR TAP	MOTOR SPEED	IWC STATIC PRESSURE									
			0.10		0.20		0.30		0.40		0.50	
			SCFM	WATTS	SCFM	WATTS	SCFM	WATTS	SCFM	WATTS	SCFM	WATTS
ECE09203*A	1	T1 ^H	317	51	300	49	281	49	263	49	244	48
	2	T2 ^C	358	64	341	63	322	62	303	62	285	61
	3	T3	510	128	493	127	474	127	456	126	437	125
	4	T4	459	103	441	102	423	101	404	101	385	100
ECE12203*A	1	T1 ^H	358	64	341	63	322	62	303	62	285	61
	2	T2 ^C	459	103	441	102	423	101	404	101	385	100
	3	T3	552	152	535	151	516	151	498	150	479	149
	4	T4	510	128	493	127	474	127	456	126	437	125
ECE12205*A	1	T1 ^H	358	64	341	63	322	62	303	62	285	61
	2	T2 ^C	459	103	441	102	423	101	404	101	385	100
	3	T3	552	152	535	151	516	151	498	150	479	149
	4	T4	510	128	493	127	474	127	456	126	437	125
ECE182203*A	1	T1	629	111	603	111	579	111	548	107	504	99
	2	T2 ^C	723	155	696	155	673	155	641	151	598	143
	3	T3	820	206	793	206	770	206	738	202	695	194
	4	T4	820	206	793	206	770	206	738	202	695	194
ECE182205*A	1	T1	629	111	603	111	579	111	548	107	504	99
	2	T2 ^C	723	155	696	155	673	155	641	151	598	143
	3	T3	820	206	793	206	770	206	738	202	695	194
	4	T4 ^H	820	206	793	206	770	206	738	202	695	194
ECE182207*A	1	T1	629	111	603	111	597	111	548	107	504	99
	2	T2 ^C	723	155	696	155	673	155	641	151	598	143
	3	T3	820	206	793	206	770	206	738	202	695	194
	4	T4 ^H	820	206	793	206	770	206	738	202	695	194
ECE182210*A	1	T1	723	155	696	155	673	155	641	151	598	143
	2	T2 ^C	723	155	696	155	673	155	641	151	598	143
	3	T3	820	206	793	206	770	206	738	202	695	194
	4	T4 ^H	820	206	793	206	770	206	738	202	695	194
ECE24205*A	1	T1	696	122	673	128	650	134	627	141	607	148
	2	T2 ^{C low}	696	122	673	128	650	134	627	141	607	148
	3	T3	784	162	762	168	738	174	716	180	695	187
	4	T4 ^{C high}	909	232	886	239	863	245	840	251	820	258
	5	T5	975	279	953	285	929	291	907	297	886	304

^C Factory Default Cooling Airflow.

^H Factory Default Electric Heat Airflow.

T3 is reserved for high static operation.

24A is for the smaller cabinet.

Blower performance data based on a dry coil at 70°F DB EAT with a standard 1" clean air filter.

Data is subject to change. Please verify most current information on www.firstco.com.

ECO SERIES COOL-PAK

SPACE CONSTRAINED AIR CONDITIONER

BLOWER PERFORMANCE (CONT'D)

MODEL	MOTOR TAP	MOTOR SPEED	IWC STATIC PRESSURE									
			0.10		0.20		0.30		0.40		0.50	
			SCFM	WATTS	SCFM	WATTS	SCFM	WATTS	SCFM	WATTS	SCFM	WATTS
ECE24207*A	1	T1	696	122	673	128	650	134	627	141	607	148
	2	T2 ^{C low}	696	122	673	128	650	134	627	141	607	148
	3	T3 ^{C high}	784	162	762	168	738	174	716	180	695	187
	4	T4 ^H	909	232	886	239	863	245	840	251	820	258
	5	T5	975	279	953	285	929	291	907	297	886	304
ECE24210*A	1	T1	784	162	762	168	738	174	716	180	695	187
	2	T2 ^{C low}	696	122	673	128	650	134	627	141	607	148
	3	T3 ^{C high}	864	205	842	211	818	217	796	224	775	231
	4	T4 ^H	909	232	886	239	863	245	840	251	820	258
	5	T5	975	279	953	285	929	291	907	297	886	304
ECE24205*B	1	T1	809	174	786	180	763	186	741	193	720	200
	2	T2 ^C	849	196	826	202	803	208	780	215	760	222
	3	T3	887	219	864	225	841	231	818	237	798	244
	4	T4 ^H	923	242	900	248	877	254	854	260	834	267
ECE24207*B	1	T1	809	174	786	180	763	186	741	193	720	200
	2	T2 ^C	849	196	826	202	803	208	780	215	760	222
	3	T3	887	219	864	225	841	231	818	237	798	244
	4	T4	923	242	900	248	877	254	854	260	834	267
ECE24210*B	1	T1	809	174	786	180	763	186	741	193	720	200
	2	T2 ^C	849	196	826	202	803	208	780	215	760	222
	3	T3	887	219	864	225	841	231	818	237	798	244
	4	T4 ^H	923	242	900	248	877	254	854	260	834	267
	5	T5	923	242	900	248	877	254	854	260	834	267
ECE30205*B	1	T1	863	227	839	228	812	225	782	219	752	213
	2	T2 ^C	1032	338	1009	339	981	336	952	330	922	324
	3	T3	977	297	953	298	926	295	896	289	866	283
	4	T4	1104	401	1080	402	1053	398	1028	393	993	386
ECE30207*B	1	T1	863	227	839	228	812	225	782	219	752	213
	2	T2 ^C	1032	338	1009	339	981	336	952	330	922	324
	3	T3	977	297	953	298	926	295	896	289	866	283
	4	T4	1104	401	1080	402	1053	398	1023	393	933	386
ECE30210*B	1	T1	863	227	839	228	812	225	782	219	752	213
	2	T2 ^C	1032	338	1009	339	981	336	952	330	922	324
	3	T3	977	297	953	298	926	295	896	289	866	283
	4	T4 ^H	1104	401	1080	402	1053	398	1023	393	993	386

^C Factory Default Cooling Airflow.

^H Factory Default Electric Heat Airflow.

T3 is reserved for high static operation.

Blower performance data based on a dry coil at 70°F DB EAT with a standard 1" clean air filter.

24A is for the smaller cabinet.

Data is subject to change. Please verify most current information on www.firstco.com.

ECO SERIES COOL-PAK

SPACE CONSTRAINED AIR CONDITIONER

RATED COOLING & HEATING PERFORMANCE

Model	Rated Airflow SCFM	Cooling Capacity (A Full) 95°F, BTUH	EER2 (A Full) 95°F EER2	SEER2
ECE09***D	300	9000	10.0	11.7
ECE12***D	400	11400	10.0	11.7
ECE18***D	600	17500	10.0	11.7
ECE24A***D	800/600	23400	10.0	11.7
ECE24B***D	800	23500	10.0	11.7
ECE30***D	950	26500	10.0	11.7

NOTE:

24A is for the smaller cabinet.

Ratings subject to change

Electric Heat Ratings						
Model	240V		230V		208V	
	kW	BTU/H	kW	BTU/H	kW	BTU/H
ECE09203*	3	10250	2.76	9450	2.25	7700
ECE12203*	3	10250	2.76	9450	2.25	7700
ECE12205*	4.5	15400	4.14	14150	3.375	11550
ECE18203*	3	10250	2.76	9450	2.25	7700
ECE18205*	5	17100	4.6	15700	3.75	12800
ECE18207*	7	23900	6.44	22000	5.25	17950
ECE18210*	9.5	32450	8.74	29850	7.125	24350
ECE24205*	5	17100	4.6	15700	3.75	12800
ECE24207*	7	23900	6.44	22000	5.25	17950
ECE24210*	9.5	32450	8.74	29850	7.125	24350
ECE30205*	5	17100	4.6	15700	3.75	12800
ECE30207*	7	23900	6.44	22000	5.25	17950
ECE30210*	9.5	32450	8.74	29850	7.125	24350

Data is subject to change. Please verify most current information on www.firstco.com.

ECO SERIES COOL-PAK

SPACE CONSTRAINED AIR CONDITIONER

EXTENDED PERFORMANCE DATA

Model	Indoor Temp DB/WB	Outdoor Temperature °F																	
		65.0			75.0			85.0			95.0			105.0			115.0		
		BTUH	S/T	W	BTUH	S/T	W	BTUH	S/T	W	BTUH	S/T	W	BTUH	S/T	W	BTUH	S/T	W
ECE09*A	75/57	8650.0	1.00	0.7	8300.0	1.00	0.7	7900.0	1.00	0.8	7500.0	1.00	0.9	7100.0	1.00	1.0	6700.0	1.00	1.0
	75/63	9750.0	0.76	0.7	9250.0	0.78	0.7	8700.0	0.79	0.8	8150.0	0.82	0.9	7650.0	0.84	1.0	7100.0	0.87	1.0
	80/67	10600.0	0.73	0.7	10100.0	0.74	0.7	9550.0	0.76	0.8	9000.0	0.78	0.9	8450.0	0.81	1.0	7850.0	0.83	1.0
	85/72	11850.0	0.65	0.7	11250.0	0.66	0.7	10700.0	0.68	0.8	10100.0	0.70	0.9	9500.0	0.72	1.0	8900.0	0.74	1.1
ECE12*A	75/57	12000	1	0.70	11150	1	0.80	10600	1	0.90	10000	1	1.00	9350	1	1.1	8750	1	1.20
	75/63	12800	0.75	0.70	12100	0.77	0.80	11350	0.79	0.90	10650	0.81	1.00	9850	0.84	1.1	9100	0.88	1.20
	80/67	13750	0.72	0.70	12950	0.74	0.80	12200	0.76	0.90	11400	0.78	1.00	10600	0.82	1.1	9800	0.85	1.20
	85/72	15150	0.62	0.70	14300	0.63	0.80	13500	0.65	0.90	12600	0.67	1.00	11750	0.69	1.1	10850	0.72	1.20
ECE18*A	75/57	18250	1	1.10	17450	1	1.20	16650	1	1.40	15850	1	1.50	15000	1	1.6	14100	1	1.80
	75/63	19350	0.79	1.10	18400	0.81	1.30	17400	0.84	1.40	13400	0.86	1.50	15450	0.9	1.7	14400	0.93	1.80
	80/67	20550	0.77	1.20	19600	0.79	1.30	18550	0.81	1.40	17500	0.84	1.60	16400	0.87	1.7	15350	0.91	1.80
	85/72	22150	0.7	1.20	21100	0.72	1.30	20000	0.74	1.50	18900	0.76	1.60	17700	0.79	1.8	16600	0.83	1.90
ECE24*A	75/57	25850	1	1.80	23250	1	2.00	21650	1	2.20	20600	1	2.40	19450	1	2.6	18250	1	2.90
	75/63	27600	0.75	1.80	24550	0.77	2.00	23200	0.79	2.20	21800	0.81	2.40	20450	0.84	2.6	19000	0.87	2.90
	80/67	27600	0.73	1.80	26250	0.75	2.00	24800	0.76	2.20	23400	0.79	2.40	21900	0.81	2.6	20400	0.84	2.90
	85/72	30150	0.66	1.80	28600	0.68	2.00	27050	0.69	2.20	25550	0.71	2.40	23900	0.73	2.7	22000	0.75	2.90
ECE24*B	75/57	25950	1	1.60	23350	1	1.90	21750	1	2.10	20700	1	2.30	19550	1	2.5	18350	1	2.80
	75/63	27700	0.72	1.60	24650	0.74	1.90	23300	0.76	2.10	21900	0.78	2.30	20550	0.81	2.5	19100	0.84	2.80
	80/67	27700	0.7	1.60	26350	0.72	1.90	24900	0.73	2.10	23500	0.76	2.30	22000	0.78	2.5	20500	0.81	2.80
	85/72	30250	0.63	1.60	28700	0.65	1.90	27150	0.66	2.10	25650	0.68	2.30	24000	0.7	2.5	22100	0.72	2.80
ECE30*B	75/57	26400	0.99	1.80	25400	1	2.00	24600	1	2.20	22800	1	2.40	21700	1	2.7	20450	1	3.00
	75/63	29150	0.72	1.80	27750	0.74	2.00	26250	0.75	2.20	24700	0.76	2.40	23200	0.79	2.7	21750	0.81	3.00
	80/67	31150	0.69	1.90	29650	0.71	2.00	28050	0.72	2.20	26500	0.74	2.50	24900	0.76	2.7	23300	0.79	3.00
	85/72	33950	0.63	1.90	32150	0.64	2.00	30600	0.65	2.20	28800	0.67	2.50	27100	0.69	2.7	25350	0.71	3.00

Extended cooling performance data tabulated based off test at rated Airflow at .3 in. H₂O of external static.

24A is for the smaller cabinet.

Data is subject to change. Please verify most current information on www.firstco.com.

ECO SERIES COOL-PAK

SPACE CONSTRAINED AIR CONDITIONER

ELECTRICAL DATA

Model	Voltage	COMPRESSOR		OUTDOOR MOTOR		INDOOR MOTOR		MIN. CIRCUIT AMPACITY (MCA) CIRCUIT 1 (L1-L2)		MAX. CIRCUIT PROTECTION (MOCP) CIRCUIT 1 (L1-L2)	
		RLA	LRA	FLA	HP	FLA	HP	240V	208V	240V	208V
ECE09203*A	208/230-1-60	4	22	2.3	1/4	2.3	1/4	19	17	20	20
ECE12203*A	208/230-1-60	4.6	25	2.3	1/4	2.3	1/4	19	17	20	20
ECE12205*A	208/230-1-60	4.6	25	2.3	1/4	2.3	1/4	27	24	30	25
ECE18203*A	208/230-1-60	7.6	36	2.3	1/4	2.8	1/3	20	18	20	20
ECE18205*A	208/230-1-60	7.6	36	2.3	1/4	2.8	1/3	30	27	30	30
ECE18207*A	208/230-1-60	7.6	36	2.3	1/4	2.8	1/3	40	36	40	40
ECE18210*A	208/230-1-60	7.6	36	2.3	1/4	2.8	1/3	53	47	55	50
ECE24205*A	208/230-1-60	10.2	58	2.3	1/4	2.8	1/3	30	27	30	30
ECE24207*A	208/230-1-60	10.2	58	2.3	1/4	2.8	1/3	40	36	40	40
ECE24210*A	208/230-1-60	10.2	58	2.3	1/4	2.8	1/3	53	47	55	50
ECE24205*B	208/230-1-60	9.6	52	2.3	1/4	2.8	1/3	30	27	30	30
ECE24207*B	208/230-1-60	9.6	52	2.3	1/4	2.8	1/3	40	36	40	40
ECE24210*B	208/230-1-60	9.6	52	2.3	1/4	2.8	1/3	53	47	55	50
ECE30205*B	208/230-1-60	10.5	71	2.8	1/3	4.1	1/2	32	28	35	30
ECE30207*B	208/230-1-60	10.5	71	2.8	1/3	4.1	1/2	42	37	45	40
ECE30210*B	208/230-1-60	10.5	71	2.8	1/3	4.1	1/2	55	48	55	50

Refer to the wiring diagrams in the ECE Installation and Operation Manual for additional details.

Wire size should be determined in accordance with National Electric Codes.

Unit are rated for 208/230V, but MOP, MCA values are calculated at 208/240V.

Data is subject to change. Please verify most current information on www.firstco.com.

ECO SERIES COOL-PAK

SPACE CONSTRAINED AIR CONDITIONER

GENERAL ASSEMBLY FOR STANDARD SLEEVE AND LOUVER

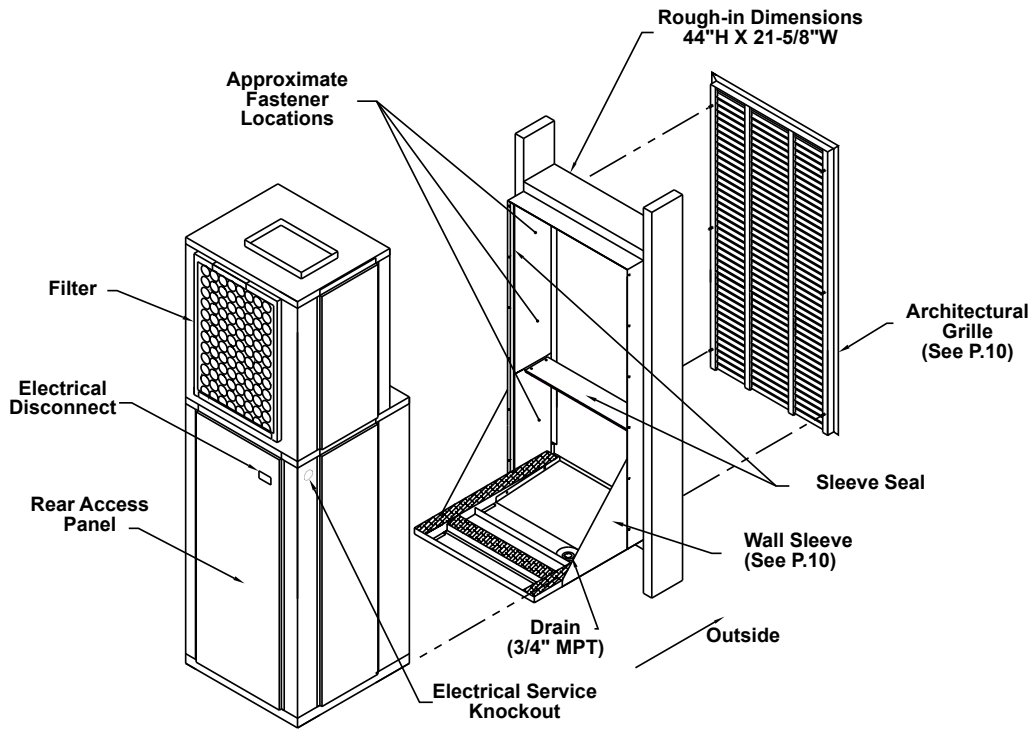

GENERAL ASSEMBLY FOR LARGE SLEEVE AND LOUVER SIZE 24B-30

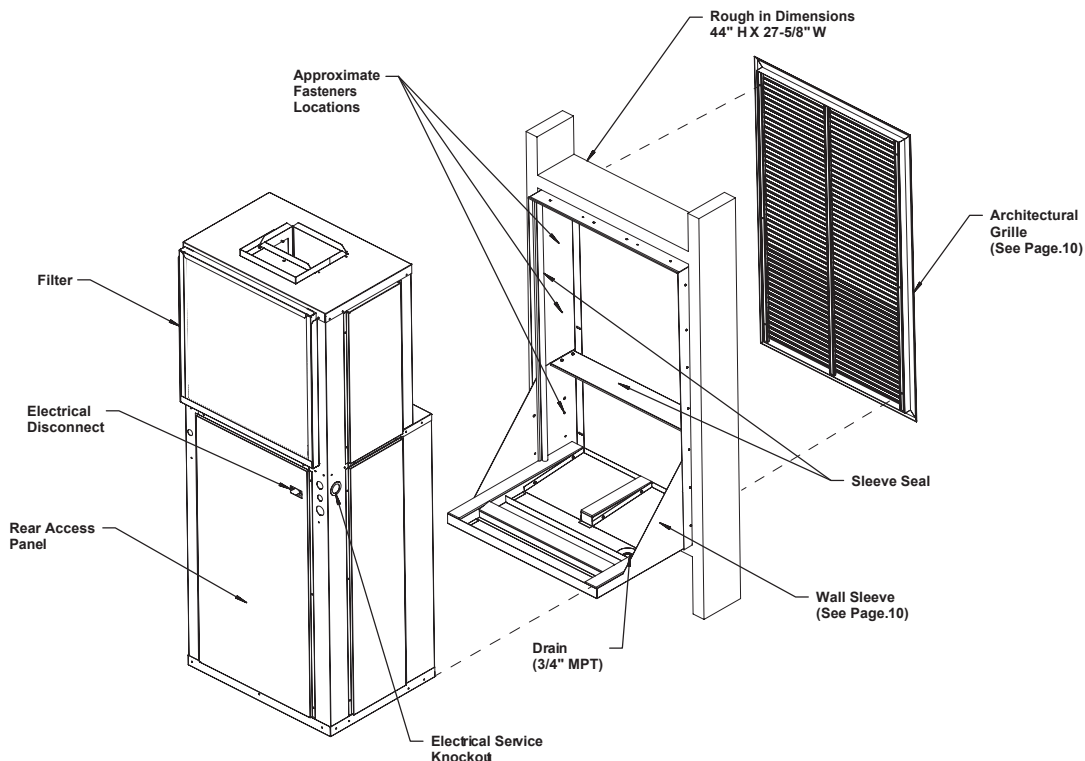

ECO SERIES COOL-PAK

SPACE CONSTRAINED AIR CONDITIONER

GENERAL ASSEMBLY FOR LARGE SLEEVE AND LOUVER FOR 09-24A SIZES WITH BLOCK OFF

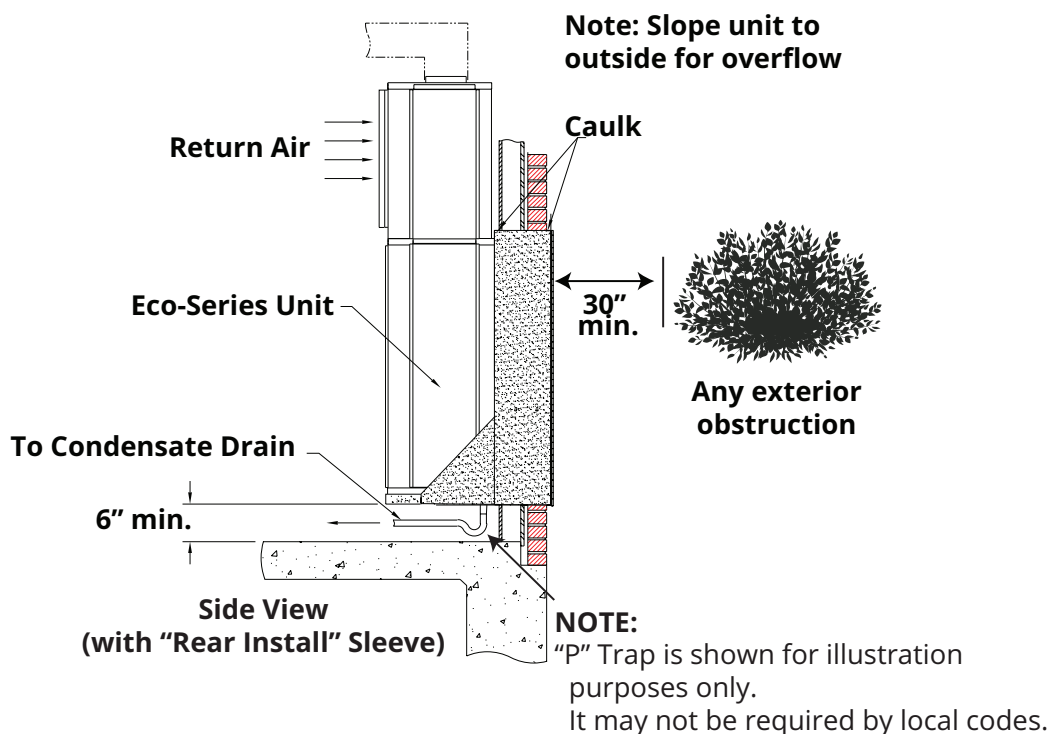
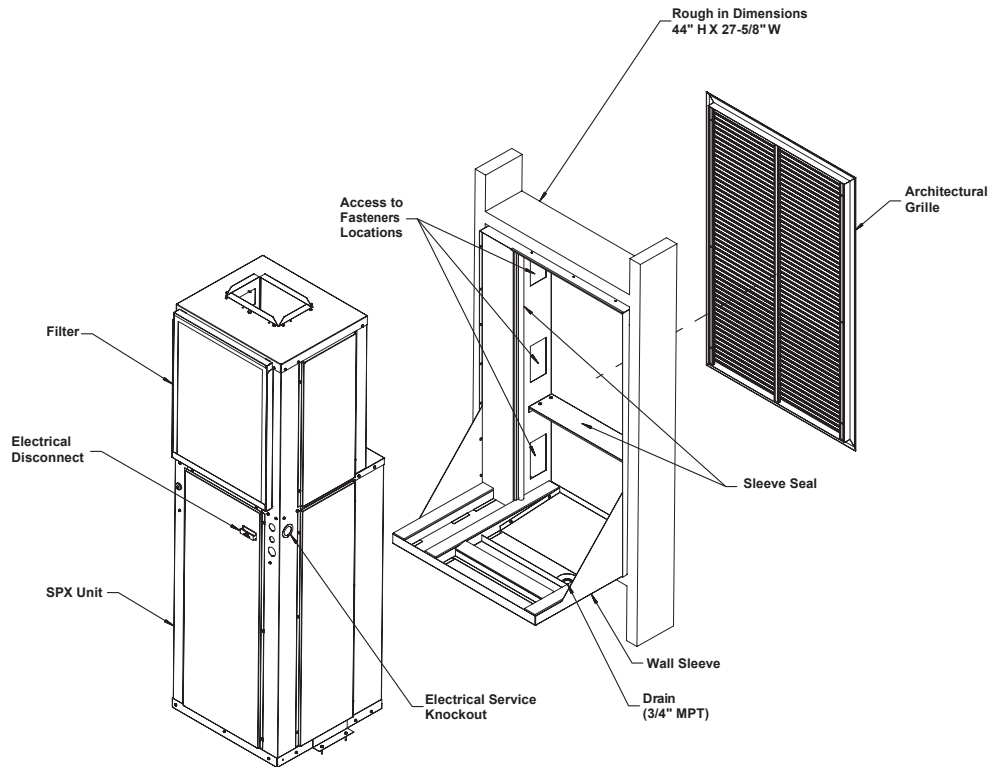

ECO SERIES COOL-PAK

SPACE CONSTRAINED AIR CONDITIONER

CLOSET DIMENSIONS

NOTES:

1. Sleeve rough-in opening is 44"(H) X 21-5/8"(W).
2. Bottom of opening should be approx. 6" above floor level.
3. Minimum 3" of clearance is required on all sides of the unit.
4. Note Wind Resistant Louver is 3/4" larger

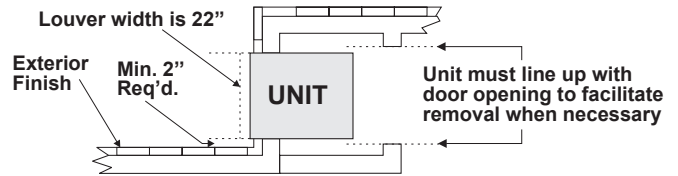

REAR INSTALLATION

DETAIL FOR SMALL SLEEVE 21" WIDE (9-24A ONLY)

INSTRUCTIONS:

To find the minimum closet depth (dimension "C"), use the following method:

Determine dimension "A" which is the total finished wall thickness.

- For 5"-8" outside wall thickness, subtract "A" from 29". ("C" = 29 - "A")
- For 8"-12" outside wall thickness, subtract "A" from 33". ("C" = 33 - "A")
- For 12"-15" outside wall thickness, subtract "A" from 36". ("C" = 36 - "A")

NOTE: Provide minimum clearances as shown for interior closet dimensions.

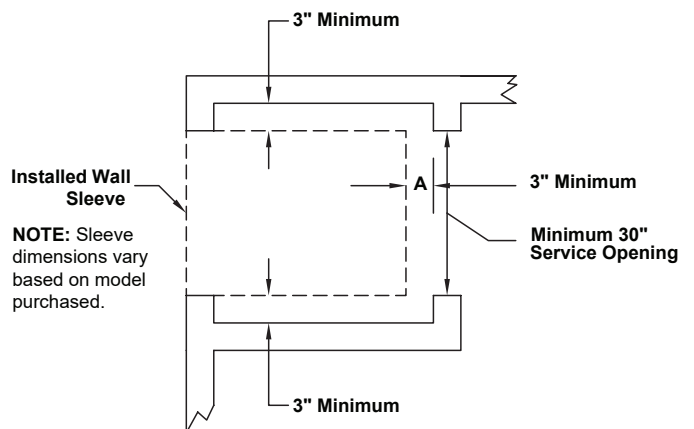

REAR INSTALLATION

DETAIL FOR LARGE SLEEVE 27" WIDE (24B, 30 SIZE OR 9-24A WITH BLOCKOFF)

NOTES:

1. Sleeve rough-in opening is 44"(H) X 27-5/8"(W).
2. Bottom of opening should be approx. 6" above floor level.
3. Minimum 3" of clearance is required on all sides of the unit.
4. Note Wind Resistant Louver is 3/4" larger

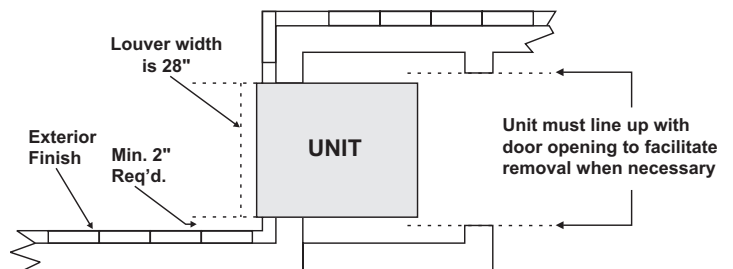

ECO SERIES COOL-PAK

SPACE CONSTRAINED AIR CONDITIONER

CLOSET DIMENSIONS (CONT'D) REAR INSTALLATION

DETAIL FOR LARGE SLEEVE 27" WIDE (24B, 30 SIZE OR 9-24A WITH BLOCKOFF)

INSTRUCTIONS:

To find the minimum closet depth (dimension "C"), use the following method:

Determine dimension "A" which is the total finished wall thickness.

- For 5"-8" outside wall thickness, subtract "A" from 39".
("C" = 39 - "A")
- For 8"-12" outside wall thickness, subtract "A" from 43".
("C" = 43 - "A")
- For 12"-15" outside wall thickness, subtract "A" from 46".
("C" = 46 - "A")

NOTE: Provide minimum clearances as shown for interior closet dimensions.

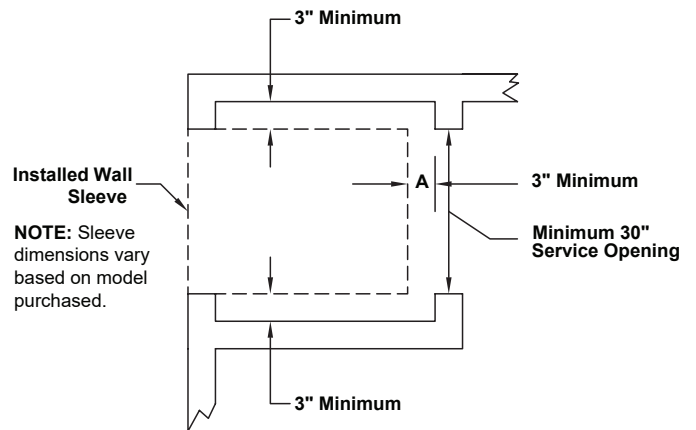

SIDE INSTALLATION

DETAIL FOR SMALL SLEEVE 21" WIDE (9-24A SIZE ONLY)

NOTES:

1. Sleeve rough-in opening is 44"(H) X 21-5/8"(W).
2. Bottom of opening should be approx. 6" above floor level.
3. Minimum 3" of clearance is required on all sides of the unit and 12" clearance on the rear.

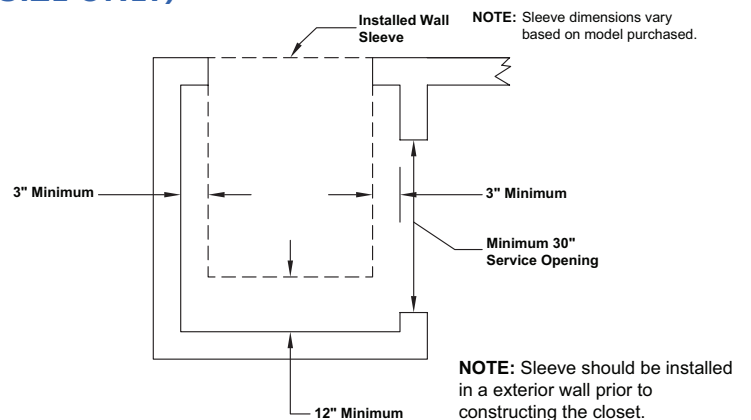

SIDE INSTALLATION

DETAIL FOR SMALL SLEEVE 27" WIDE (24B, 30 SIZE OR 9-24A WITH BLOCK OFF)

NOTES:

1. Sleeve rough-in opening is 44"(H) X 21-5/8"(W).
2. Bottom of opening should be approx. 6" above floor level.
3. Minimum 3" of clearance is required on all sides of the unit and 12" clearance on the rear.

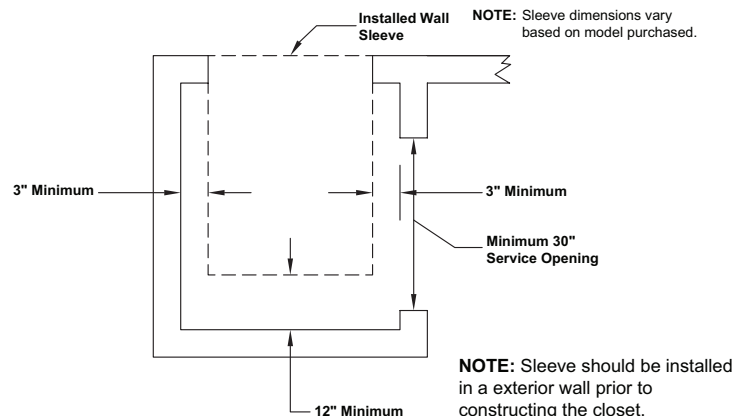



AMERICAN-MADE. FAMILY OWNED.



FIRST CO.
P.O. BOX 270969 - DALLAS, TEXAS 75227
PH. (214) 388-5751 | FAX (214) 388-2255
WWW.FIRSTCO.COM

SEPTEMBER 2024