



CLX-HW

Air Handler



1 - 3 Ton Cooling or Heat Pump

Up to 55,000 BTUH Hydronic Heating



CLX-HW

Today's higher efficiency air handlers are typically too large to fit into many smaller, space constrained closets. The **CLX-HW** Series air handler is specifically designed to solve this problem. In addition, it's short height (less than 36"), makes it ideal for those applications where the closet space is minimal.

All **CLX-HW** fan coils include an ECM motor. These motors offer the efficiency of a variable speed type ECM motor, but at a considerably lower cost. Return air (ducted or free) can come from the left side or the right side of the cabinet (determined by looking at the front of the cabinet) and must be identified at the time of order entry.

A high efficiency coil is factory installed on either side of the cabinet, and is available with a factory installed R-410A TXV. A 1" disposable filter is also factory installed within the cabinet and is easily accessible.

These fan coils are compatible with any source of hot water that does not exceed 180° and is NSF/ANSI certified for use with domestic water.

STANDARD FEATURES

- High efficiency ECM motor
- Less than 36" tall
- Right or left hand return air (order must specify)
- Compatible with most major brands of condensing units and heat pumps
- Hot water coil
- High efficiency copper tube / aluminum fin coil with factory installed R-410A TXV (non-bleed type)
- 120V motor, 24V controls
- Coil drain pan is coated with insulation to reduce corrosion
- Painted cabinet
- Factory installed hanger flange for wall mounting
- Easily accessible 1" disposable filter
- Shipped with wall mounting bracket

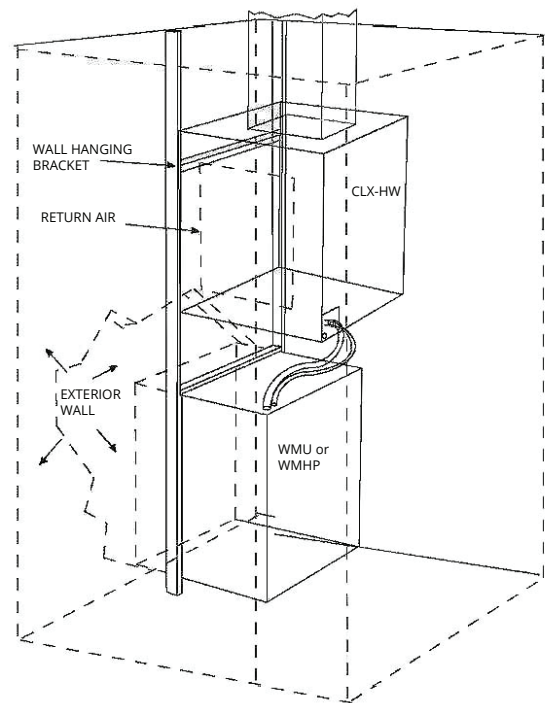

Typical installation over a Through the Wall Condensing Unit or Heat Pump

First Co's customer is ultimately responsible for confirming which fan coil models are compatible with selected outdoor unit(s) and which expansion valves (if any) are required. To determine certified indoor/outdoor combinations, go to www.firstco.com or contact the factory.

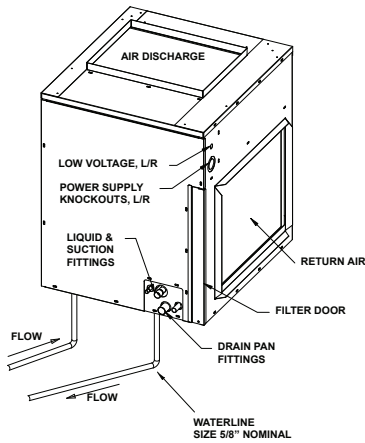

DIMENSIONS										
UNIT MODEL	H	W	D	A	B	C	E	F	G	SHIP WT.
12CLX-HW	27-3/8	22-3/8	24-3/8	15-7/8	20-1/2	16	12	2-3/8	7-3/4	110 LBS.
24CLX-HW	27-3/8	22-3/8	24-3/8	15-7/8	20-1/2	16	12	2-3/8	7-3/4	120 LBS.
25/36CLX-HW	29-3/8	26-3/8	26-3/8	18-3/8	23-2/8	18	16	3	7-1/4	130 LBS.
37CLX-HW	35-3/8	26-3/8	26-3/8	18-3/8	23-2/8	18	16	3	7-1/4	140 LBS.

BLOWER DATA										
UNIT MODEL	FAN SPEED TAP	AMP (120V)	MOTOR HP	CFM VS EXTERNAL PRESSURE						
				0.1	0.15	0.2	0.25	0.3	0.4	0.5
12CLX-HW	WHT	3.5	1/4	540	525	515	500	485	455	425
	VIO			515	500	485	470	455	425	390
	GRY			305	285	265	240	220	175	-
24CLX-HW	5	6.8	1/2	845	825	800	780	755	710	650
	4			835	815	790	770	745	700	640
	3			755	685	730	670	700	675	620
	2			600	587	570	570	540	510	485
25CLX-HW	5	6.8	1/2	970	955	940	930	920	860	800
	4			820	805	790	775	760	720	690
	3			650	630	610	585	560	510	460
	2			550	525	500	475	450	400	350
36CLX-HW	5	8.4	3/4	1270	1230	1195	1165	1135	1060	965
	4			1180	1160	1140	1116	1090	1035	940
	3			1040	1020	1005	985	965	925	890
	2			970	950	925	905	885	845	810
37CLX-HW	5	8.4	3/4	1340	1320	1300	1285	1270	1250	1220
	4			1180	1165	1150	1130	1110	1090	1060
	3			1050	1030	1010	995	980	950	920
	2			930	915	900	880	860	820	760

MODEL NUMBERS

MODEL SIZE (BTU)	MODEL (R-410A TXV)
12,000	12CLX-HW (-RH or LH) R410 TXV
24,000 / 18,000	24/25CLX-HW (-RH or LH) R410 TXV
36,000 / 30,000	36/37CLX-HW (-RH or LH) R410 TXV

All models are approved for cooling only (non-bleed type).
EXAMPLE: 36CLX-HW-RH R410 TXV
 (3 Ton Right Hand Return with Installed R-410A TXV)

HEATING PERFORMANCE					
UNIT MODEL	NOM. CFM	BTUH ENTERING WATER TEMP. Delta-T 20°F & GPM			
		130° F	GPM	140°F	GPM
12CLX-HW	275	14,500	1.5	16,900	1.7
	400	18,850	1.9	22,000	2.2
24CLX-HW	600	25,700	2.6	30,000	3.0
	700	28,300	2.8	33,000	3.3
	800	30,800	3.1	36,000	3.6
25CLX-HW	600	27,300	2.7	31,900	3.2
	700	30,500	3.1	45,600	4.6
	800	33,300	3.3	38,900	3.9
36/37CLX-HW	1000	42,000	4.2	49,000	4.9
	1200	47,000	4.7	55,000	5.5

- Heat BTUH is at 70°F entering air temperature.
- Based on 20°F Delta-T. Velocity not to exceed 4ft./sec.

ELECTRICAL DATA				
UNIT MODEL	MOTOR HP	AMPS	MIN. CIRCUIT AMPACITY	MAX. FUSE OR HACR BREAKER
		MOTOR	120V	120V
12CLX-HW	1/4	3.5	5.0	15
24/25CLX-HW	1/2	6.8	9.0	15
36/37CLX-HW	3/4	8.4	11.0	15

COOLING COIL DATA (FACTORY INSTALLED)				
PRODUCT NUMBER	NOMINAL COOLING (TONS)	STANDARD METERING DEVICE	COIL CONNECTION (LIQ. & SUCT.)	FILTER
12CLX-HW	1.0 tons	TXV	3/8 O.D. / 5/8 O.D. (SWEAT)	18 X 24 X 1
24CLX-HW	2.0 / 1.5 tons	TXV		18 X 24 X 1
25CLX-HW	2.0 / 1.5 tons	TXV		20 X 25 X 1
36CLX-HW	3.0 / 2.5 tons	TXV		20 X 25 X 1
37CLX-HW	3.0 / 2.5 tons	TXV		25 X 25 X 1



In keeping with its policy of continuous progress and product improvement, First Co. reserves the right to make changes without notice.



FIRST CO.
P.O. BOX 270969 - DALLAS, TEXAS 75227
PH. (214) 388-5751 | FAX (214) 388-2255
WWW.FIRSTCO.COM

JULY 2024