

First Co.

CL SERIES

CLP • CLX

Closet Fan Coils

**Compatible with R410A
For Servicing Existing Equipment Only**

Upflow / Closet Fan Coil

1 – 3 Ton Cooling or Heat Pump

Up to 10 kW Electric Heat



TABLE OF CONTENTS

NOMENCLATURE	3
SERIES FEATURES	4
CLP HEAT PUMP OR DX W/ELECTRIC HEAT & PSC MOTOR.....	5
CLPQ HEAT PUMP OR DX W/STANDARD PUMP & PSC MOTOR.....	7
CLPW HEAT PUMP OR DX W/HOT WATER COIL & PSC MOTOR.....	10
CLXHEAT PUMP OR DX – WITH ELECTRIC HEAT & ECM MOTOR.....	13
CLXQHEAT PUMP OR DX W/STANDARD PUMP & ECM MOTOR	17
CLXW HEAT PUMP OR DX W/HOT WATER COIL & ECM MOTOR.....	20

First Co.'s customer is ultimately responsible for confirming which fan coil models are compatible with selected outdoor unit(s) and which expansion valves (if any) are required. To determine certified indoor/outdoor combinations, go to www.firstco.com or contact the factory.

In keeping with its policy of continuous progress and product improvement, First Co. reserves the right to make changes without notice.

NOMENCLATURE

FULL SERIES NOMENCLATURE

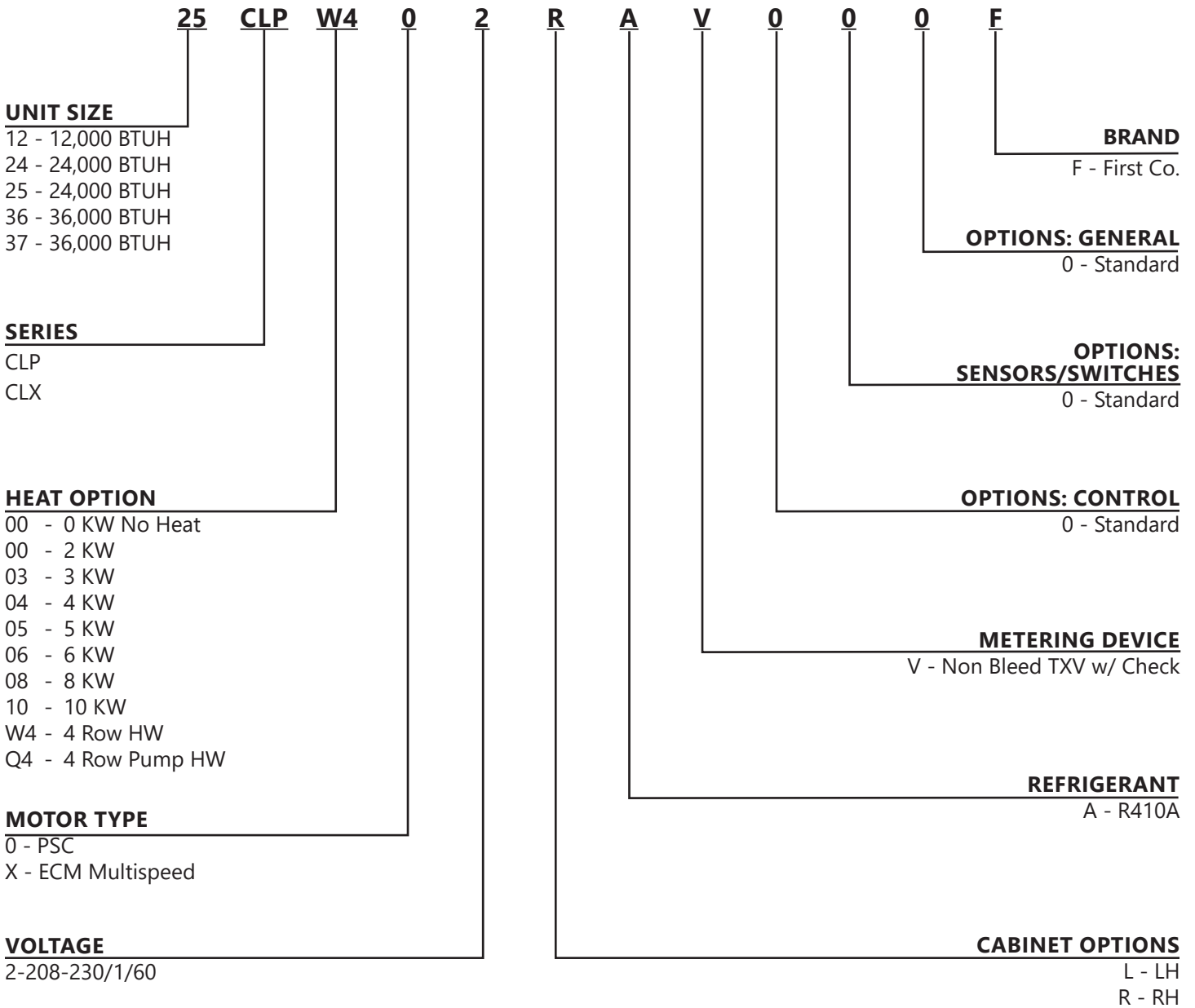

Model specific NOMENCLATURE presented at each respective section of document.

CL SERIES

CLOSET FAN COIL

FEATURES

Today's higher efficiency air handlers are typically too large to fit into many smaller, space constrained closets. The CL Series air handler is specifically designed to solve this problem. In addition, it's short height (less than 36"), makes it ideal for those applications where the existing air handler is located over an electric water heater. These upflow air handlers are designed for use with today's higher efficiency split-system condensing units and heat pumps.

All CLX fan coils include a high efficiency constant torque ECM motor. These motors offer the efficiency of a variable speed type ECM motor, but at a considerably lower cost. ECM motors are up to 33 percent more efficient than PSC motors at the rated operating speed.

Return air (ducted or free return) can come from the left side or the right side of the cabinet (determined by looking at the front of the cabinet) and must be identified at the time of order entry.

A high efficiency coil is factory installed on either side of the cabinet, and is standard with a factory installed TXV. A 1" disposable filter is also factory installed within the cabinet and is easily accessible.

STANDARD FEATURES

- Less than 36" tall
- Right or left hand return air (order must specify)
- Compatible with most major brands of condensing units and heat pumps (see (1) above)
- Up to 10 kW of electric heat
- High efficiency copper tube / aluminum fin coil with factory installed TXV (non-bleed type)
- 240V motor, 24V controls
- Coil drain pan is coated with insulation to reduce corrosion
- Factory installed hanger flange for wall mounting
- Easily accessible 1" disposable filter
- Shipped with wall mounting bracket

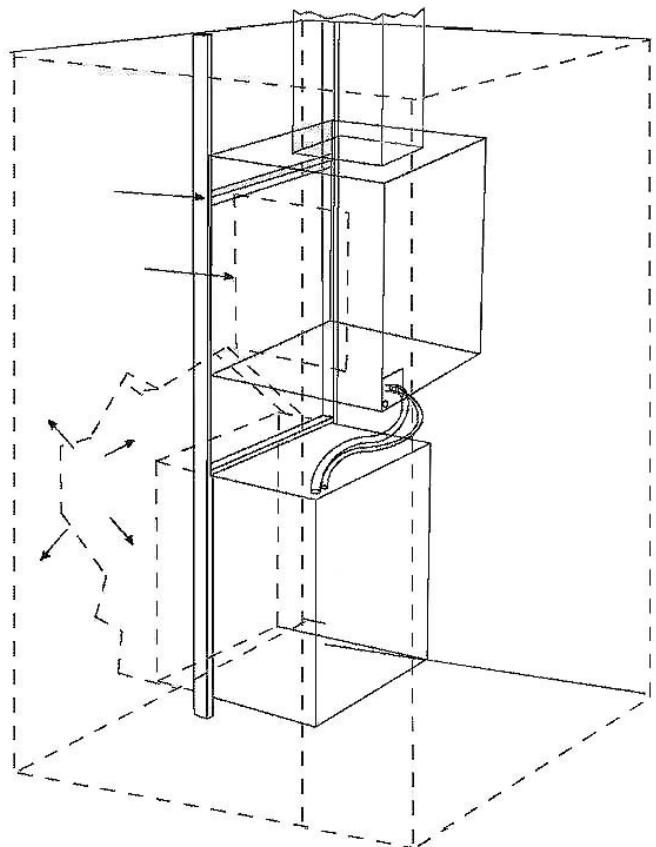

CL SERIES

CLP

HEAT PUMP OR DX W/ELECTRIC HEAT & PSC MOTOR

25 CLP 05 0 2 R A V 0 0 0 F

UNIT SIZE

- 12 - 12,000 BTUH
- 24 - 24,000 BTUH
- 25 - 24,000 BTUH
- 36 - 36,000 BTUH
- 37 - 36,000 BTUH

SERIES

CLP

HEAT OPTION

- 00 - 0 KW No Heat
- 00 - 2 KW
- 03 - 3 KW
- 04 - 4 KW
- 05 - 5 KW
- 06 - 6 KW
- 08 - 8 KW
- 10 - 10 KW

MOTOR TYPE

0 - PSC

VOLTAGE

2-208-230/1/60

CABINET OPTIONS

- L - LH
- R - RH

BRAND

F - First Co.

OPTIONS: GENERAL

0 - Standard

OPTIONS: SENSORS/SWITCHES

0 - Standard

OPTIONS: CONTROL

0 - Standard

METERING DEVICE

V - Non Bleed TXV w/ Check

REFRIGERANT

A - R410A

CL SERIES

HEAT PUMP OR DX W/ELECTRIC HEAT & PSC MOTOR

CLP

DATA TABLES

CLP

PHYSICAL DIMENSIONS										
UNIT MODEL	H	W	D	A	B	C	E	F	G	SHIP WT.
24CLP	27-3/8	22-3/8	24-3/8	15-7/8	20-1/2	16	16	2-3/8	4	120 LBS.
36CLP	29-3/8	26-3/8	26-3/8	18-3/8	23-2/8	18	16	3	5	130 LBS.

COOLING COIL DATA (FACTORY INSTALLED)				
UNIT MODEL	NOMINAL COOLING (TONS)	STANDARD METERING DEVICE	COIL CONNECTION (LIQ. & SUCT.)	FILTER
24CLP	2.0 / 1.5 tons	TXV	3/8 I.D. / 5/8 I.D. (SWEAT)	18 X 24 X 1
36CLP	3.0 / 2.5 tons	TXV		20 X 25 X 1

BLOWER DATA										
UNIT MODEL	FAN SPEED	AMP (230V)	MOTOR HP	CFM vs EXTERNAL STATIC PRESSURE						
				.10	.15	.20	.25	.30	.40	.50
24CLP	HIGH	1.6	1/6	820	815	810	800	795	755	700
	LOW			600	595	585	575	565	525	500
36CLP	HIGH	2.5	1/3	1510	1480	1455	1425	1400	1345	1280
	LOW			1130	1120	1110	1100	1090	1060	1010

PERFORMANCE DATA												
UNIT MODEL	NOM. CFM	ELECTRIC HEAT CAPACITY				TOTAL AMPS		MIN. CIR. AMPACITY		MAX. FUSE OR HACR BREAKER		
		kW		MBTUH		240V	208V	240V	208V	240V	208V	
		240V	208V	240V	208V							
24CLP	2	2.0	1.5	6.8	5.1	9.5	8.4	12.0	11.0	15.0	15.0	
	3	3.0	2.3	10.2	7.9	13.7	12.3	18.0	15.0	20.0	15.0	
	4	4.0	3.0	13.6	10.2	17.9	15.6	23.0	20.0	25.0	20.0	
	5	5.0	3.8	17.0	13.0	22.0	19.5	28.0	25.0	30.0	25.0	
	6	6.0	4.5	20.5	15.3	26.2	22.8	33.0	29.0	35.0	30.0	
	8	8.0	6.0	27.3	20.5	34.5	30.0	44.0	38.0	45.0	40.0	
	10	10.0	7.5	34.1	25.6	42.9	37.3	54.0	47.0	60.0	50.0	
36CLP	2	2.0	1.5	6.8	5.1	10.8	9.7	14.0	12.0	15.0	15.0	
	3	3.0	2.3	10.2	7.9	15.0	13.6	19.0	17.0	20.0	20.0	
	4	4.0	3.0	13.6	10.2	19.2	16.9	24.0	21.0	25.0	25.0	
	5	5.0	3.8	17.0	13.0	23.3	20.8	29.0	26.0	30.0	30.0	
	6	6.0	4.5	20.5	15.3	27.5	24.1	35.0	30.0	35.0	30.0	
	8	8.0	6.0	27.3	20.5	35.8	31.3	45.0	39.0	45.0	40.0	
	10	10.0	7.5	34.1	25.6	44.2	38.6	55.0	48.0	60.0	50.0	

CL SERIES

CLPQ

HEAT PUMP OR DX W/STANDARD PUMP & PSC MOTOR

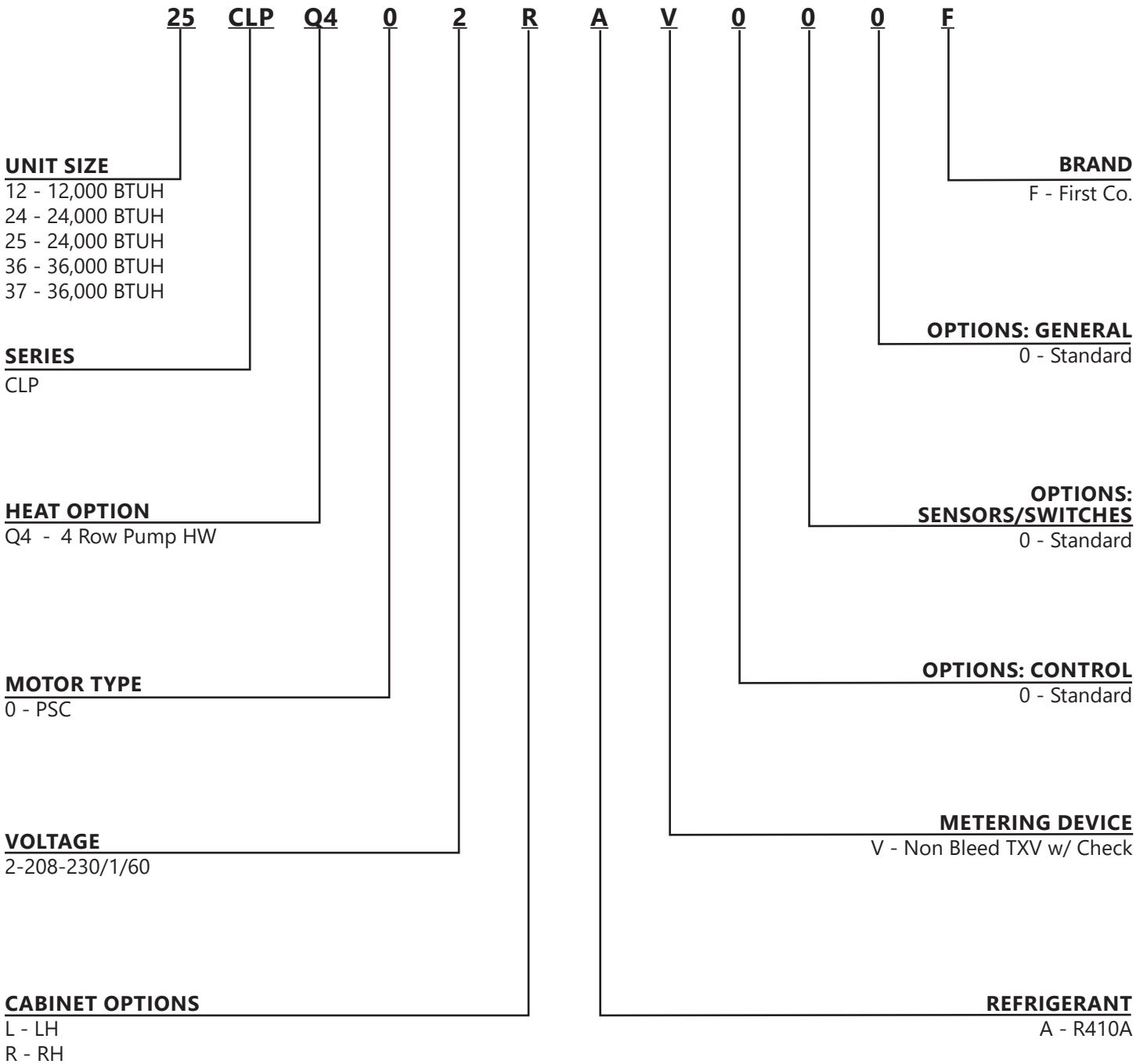

CL SERIES

HEAT PUMP OR DX W/STANDARD PUMP & PSC MOTOR

CLPQ

DATA TABLES

CLPQ

COOLING OR HEAT PUMP
HYDRONIC HEAT

DIMENSIONS										
UNIT MODEL	H	W	D	A	B	C	E	F	G	SHIP WT.
24CLPQ	27-3/8	22-3/8	24-3/8	15-7/8	20-1/2	16	12	2-3/8	7-3/4	120 LBS.
36CLPQ	29-3/8	26-3/8	26-3/8	18-3/8	23-2/8	18	16	3	7-1/4	130 LBS.

COOLING COIL DATA (FACTORY INSTALLED)				
PRODUCT NUMBER	NOMINAL COOLING (TONS)	STANDARD METERING DEVICE	COIL CONNECTION (LIQ. & SUCT.)	FILTER
24CLPQ	2.0 / 1.5 tons	TXV	3/8 I.D. / 5/8 I.D. (SWEAT)	18 X 24 X 1
36CLPQ	3.0 / 2.5 tons	TXV		20 X 25 X 1

ELECTRICAL DATA					
UNIT MODEL	MOTOR HP	AMPS		MIN. CIRCUIT AMPACITY	MAX. FUSE OR HACR BREAKER
		MOTOR	PUMP	120V	120V
24CLPQ	1/4	4.43	.57	7.0	15
36CLPQ	1/2	8.10	.57	11.0	15

BLOWER DATA										
UNIT MODEL	FAN SPEED	AMP (120V)	MOTOR HP	CFM vs EXTERNAL STATIC PRESSURE						
				.10	.15	.20	.25	.30	.40	.50
24CLPQ	HIGH	4.43	1/4	785	765	740	720	695	645	590
	LOW			445	440	430	402	410	385	350
36CLQ	HIGH	8.1	1/2	1230	1195	1160	1125	1090	1010	930
	LOW			1080	1050	1025	995	965	895	825

CLPQ

COOLING OR HEAT PUMP HYDRONIC HEAT

HEATING PERFORMANCE					
UNIT MODEL	NOM. CFM	BTUH ENTERING WATER TEMPERATURE Delta-T 20° F and GPM			
		130°	GPM	140°	GPM
24CLPQ	600	25,700	2.6	30,000	3.0
	700	28,300	2.8	33,000	3.3
	800	30,800	3.1	36,000	3.6
36CLPQ	1000	42,000	4.2	49,000	4.9
	1200	47,000	4.7	55,000	5.5

1. Heat BTUH is at 70°F entering air temperature.
2. Based on 20°F Delta-T. Velocity not to exceed 4ft./sec.

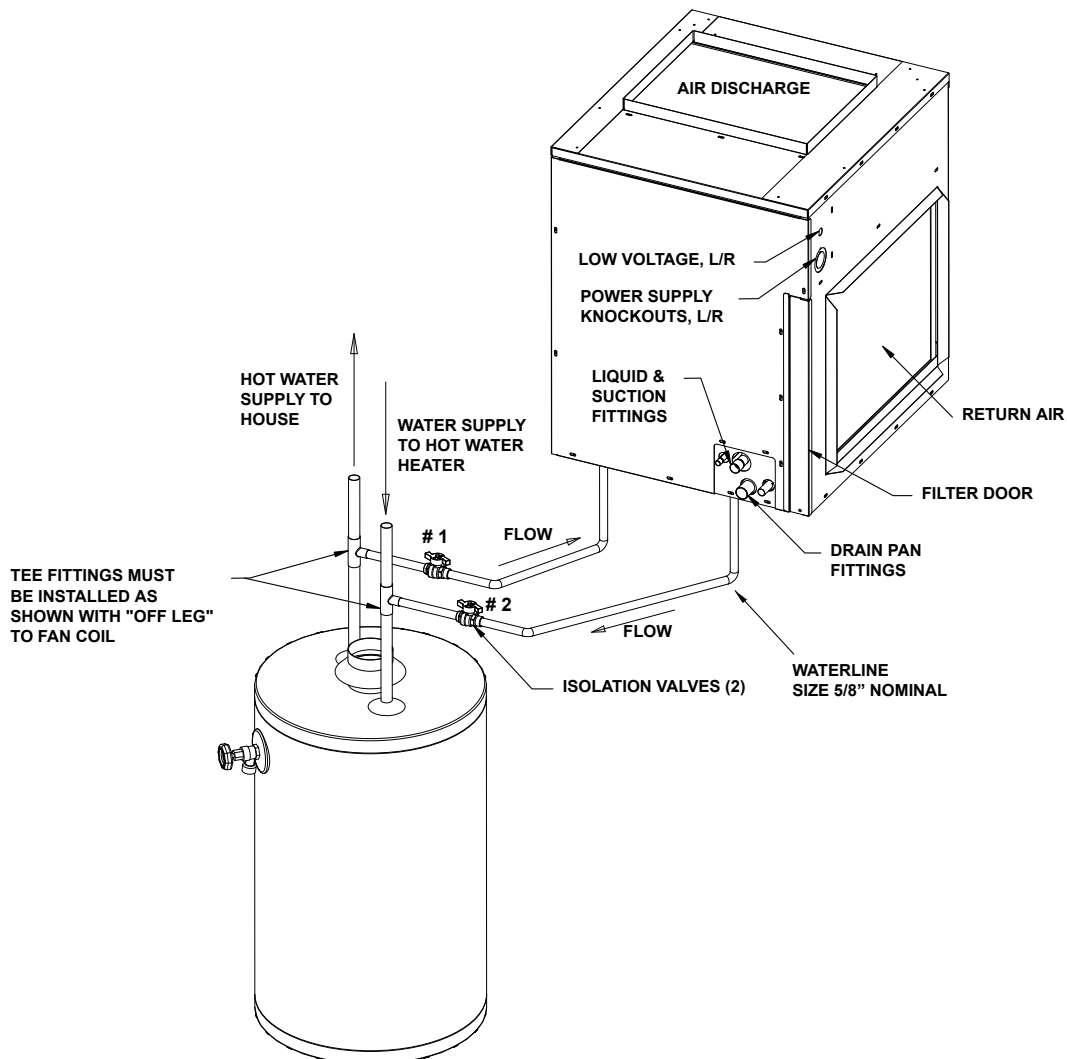

CL SERIES

CLPW

HEAT PUMP OR DX W/HOT WATER COIL & PSC MOTOR

25 **CLP** **W4** **0** **2** **R** **A** **V** **0** **0** **0** **F**

UNIT SIZE

- 12 - 12,000 BTUH
- 24 - 24,000 BTUH
- 25 - 24,000 BTUH
- 36 - 36,000 BTUH
- 37 - 36,000 BTUH

SERIES

CLP

HEAT OPTION

W4 - 4 Row HW

MOTOR TYPE

0 - PSC

VOLTAGE

2-208-230/1/60

CABINET OPTIONS

- L - LH
- R - RH

BRAND

F - First Co.

OPTIONS: GENERAL

0 - Standard

OPTIONS: SENSORS/SWITCHES

0 - Standard

OPTIONS: CONTROL

0 - Standard

METERING DEVICE

V - Non Bleed TXV w/ Check

REFRIGERANT

A - R410A

CL SERIES

HEAT PUMP OR DX W/HOT WATER COIL & PSC MOTOR

CLPW

DATA TABLES

CLPW

DIMENSIONS										
UNIT MODEL	H	W	D	A	B	C	E	F	G	SHIP WT.
24CLPW	27-3/8	22-3/8	24-3/8	15-7/8	20-1/2	16	12	2-3/8	7-3/4	120 LBS.
36CLPW	29-3/8	26-3/8	26-3/8	18-3/8	23-2/8	18	16	3	7-1/4	130 LBS.

COOLING COIL DATA (FACTORY INSTALLED)				
PRODUCT NUMBER	NOMINAL COOLING (TONS)	STANDARD METERING DEVICE	COIL CONNECTION (LIQ. & SUCT.)	FILTER
24CLPW	2.0 / 1.5 tons	TXV	3/8 I.D. / 5/8 I.D. (SWEAT)	18 X 24 X 1
36CLPW	3.0 / 2.5 tons	TXV		20 X 25 X 1

ELECTRICAL DATA				
UNIT MODEL	MOTOR HP	AMPS	MIN. CIRCUIT AMPACITY	MAX. FUSE OR HACR BREAKER
		MOTOR	120V	120V
24CLPW	1/4	4.43	6.0	15
36CLPW	1/2	8.10	10.0	15

BLOWER DATA										
UNIT MODEL	FAN SPEED	AMP (120V)	MOTOR HP	CFM vs EXTERNAL STATIC PRESSURE						
				.10	.15	.20	.25	.30	.40	.50
24CLPW	HIGH	4.43	1/4	785	765	740	720	695	645	590
	LOW			445	440	430	402	410	385	350
36CLPW	HIGH	8.1	1/2	1230	1195	1160	1125	1090	1010	930
	LOW			1080	1050	1025	995	965	895	825

CL SERIES

HEAT PUMP OR DX W/HOT WATER COIL & PSC MOTOR

CLPW

DATA TABLES

CLPW (CONT'D)

HEATING PERFORMANCE					
UNIT MODEL	NOM. CFM	BTUH ENTERING WATER TEMPERATURE – Delta-T 20° F & GPM			
		130°F	GPM	140°F	GPM
24CLPW	600	25,700	2.6	30,000	3.0
	700	28,300	2.8	33,000	3.3
	800	30,800	3.1	36,000	3.6
36CLPW	1000	42,000	4.2	49,000	4.9
	1200	47,000	4.7	55,000	5.5

1. Heat BTUH is at 70°F entering air temperature.
2. Based on 20°F Delta-T. Velocity not to exceed 4ft./sec.

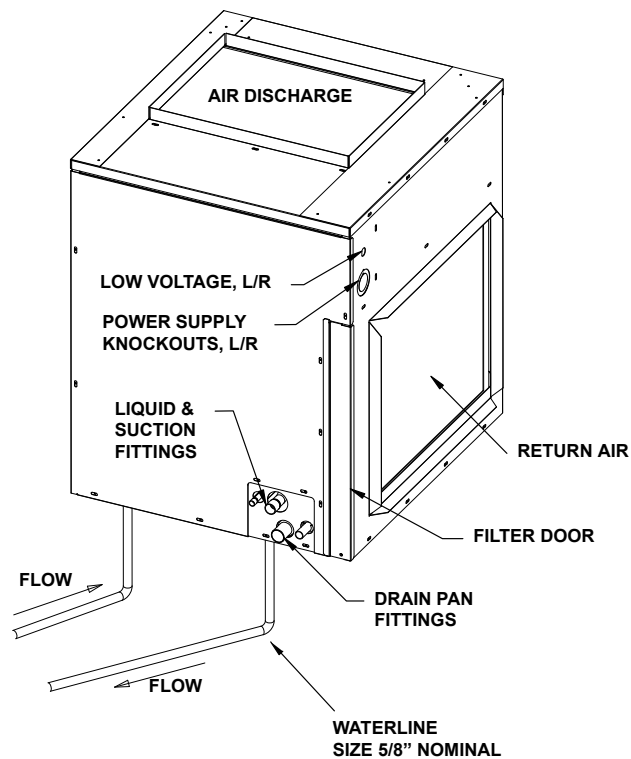

Drain Connections:
 Primary 3/4" MPT
 Secondary 3/4" OD Sweat

CL SERIES

CLX

HEAT PUMP OR DX W/ELECTRIC HEAT & ECM MOTOR

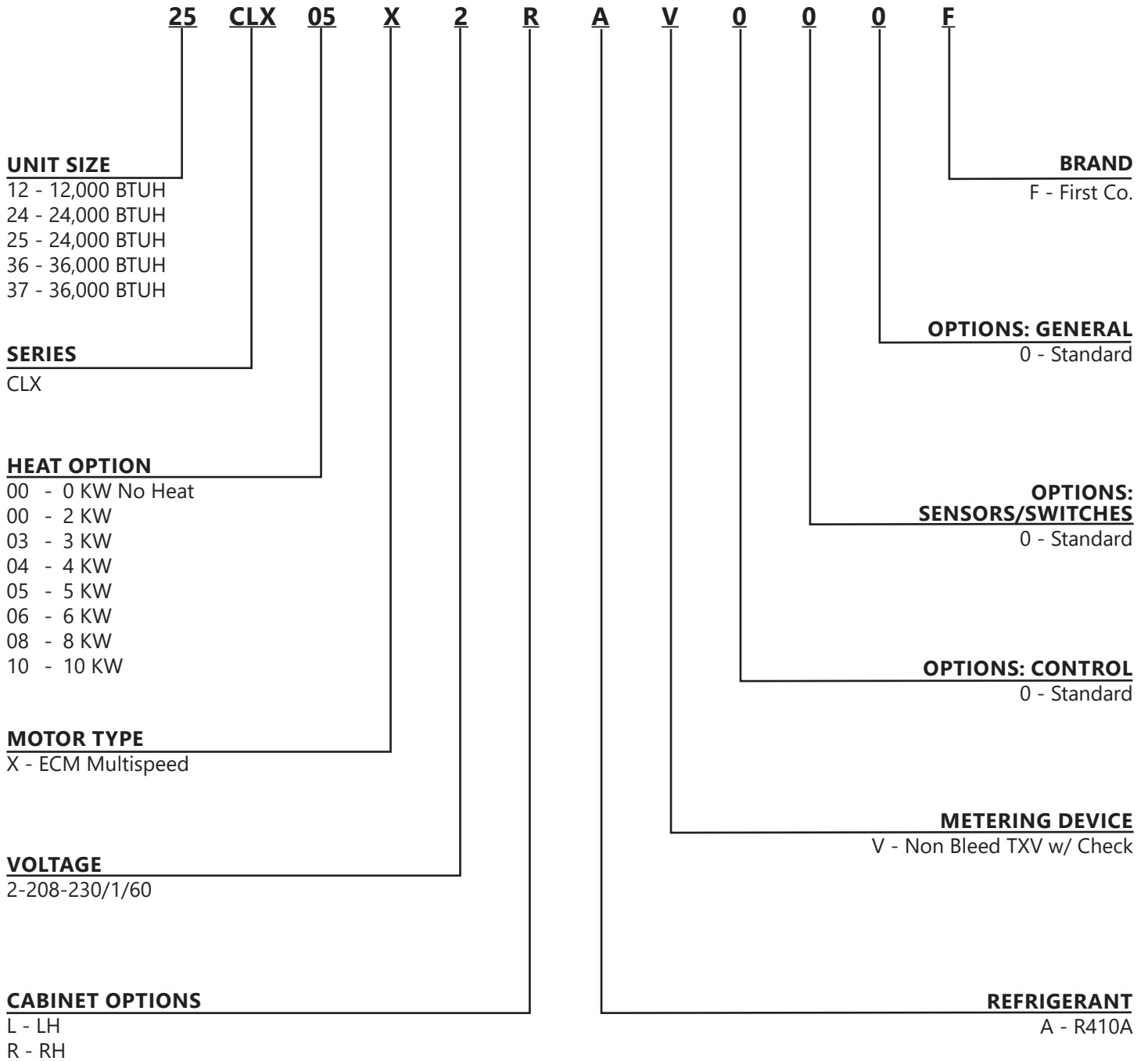

CL SERIES

HEAT PUMP OR DX W/ELECTRIC HEAT & ECM MOTOR

CLX

DATA TABLES

CLX (CONT'D)

PERFORMANCE DATA												
UNIT MODEL		NOM. BTUH CLG.	ELECTRIC HEAT CAPACITY				TOTAL AMPS		MIN. CIR. AMPACITY		MAX. FUSE OR HACR BREAKER	
			kW		MBTUH							
			240V	208V	240V	208V	240V	208V	240V	208V	240V	208V
12CLX	2	12,000	2.0	1.5	6.8	5.1	10.6	9.5	14	12	15.0	15.0
	3		3.0	2.3	10.2	7.9	14.8	13.1	19	17	20.0	20.0
	4		4.0	3.0	13.6	10.2	19.0	16.7	24	21	25.0	25.0
	5		5.0	3.8	17.0	13.0	23.1	20.3	29	26	30.0	30.0
24/25CLX	2	24,000/ 18,000	2.0	1.5	6.8	5.1	11.1	10.0	14	13	15.0	15.0
	3		3.0	2.3	10.2	7.9	15.3	13.9	19	17	20.0	20.0
	4		4.0	3.0	13.6	10.2	19.5	17.2	24	22	25.0	25.0
	5		5.0	3.8	17.0	13.0	23.6	21.1	30	26	30.0	30.0
	6		6.0	4.5	20.5	15.3	27.8	24.4	35	31	35.0	35.0
	8		8.0	6.0	27.3	20.5	36.1	31.6	45	40	45.0	40.0
36/37CLX	10	36,000/ 30,000	10.0	7.5	34.1	25.6	44.5	38.9	56	49	60.0	50.0
	2		2.0	1.5	6.8	5.1	12.4	11.3	16	14	20.0	15.0
	3		3.0	2.3	10.2	7.9	16.6	15.2	21	19	25.0	20.0
	4		4.0	3.0	13.6	10.2	20.8	18.5	26	23	30.0	25.0
	5		5.0	3.8	17.0	13.0	24.9	22.4	31	28	35.0	30.0
	6		6.0	4.5	20.5	15.3	29.1	25.7	36	32	40.0	35.0
36/37CLX	8	36,000/ 30,000	8.0	6.0	27.3	20.5	37.4	32.9	47	41	50.0	45.0
	10		10.0	7.5	34.1	25.6	45.8	40.2	57	50	60.0	50.0

CL SERIES

HEAT PUMP OR DX W/ELECTRIC HEAT & ECM MOTOR

CLX

DATA TABLES

CLX (CONT'D)

BLOWER DATA										
UNIT MODEL	FAN SPEED TAP	MOTOR AMPS (230V)	MOTOR HP	CFM VS EXTERNAL STATIC PRESSURE						
				0.10	0.15	0.20	0.25	0.30	0.40	0.50
12CLX	WHT	2.3	1/4	545	530	510	495	480	---	---
	GRY			505	490	475	455	440	---	---
	VIO			315	290	265	235	205	---	---
24CLX	5	2.8	1/3	880	865	850	845	840	830	790
	4			790	780	770	765	760	740	710
	3			690	685	680	670	660	620	595
	2			590	585	585	570	550	510	485
25CLX	4	2.8	1/3	960	940	920	900	880	840	800
	3			820	800	780	720	740	690	650
	2			650	620	590	565	540	470	410
	1			550	520	490	455	420	---	---
36CLX	5	4.1	1/2	1390	1370	1350	1335	1320	1280	1240
	4			1250	1230	1210	1190	1170	1130	1090
	3			1100	1080	1060	1040	1020	970	920
	2			830	805	780	755	730	680	630
37CLX	5	4.1	1/2	1330	1315	1300	1275	1250	1220	1190
	4			1190	1170	1150	1135	1120	1080	1050
	3			1060	1040	1020	1000	980	940	900
	2			940	915	890	870	850	810	760

CL SERIES

HEAT PUMP OR DX W/ELECTRIC HEAT & ECM MOTOR

CLX

DATA TABLES

CLX (CONT'D)

COOLING COIL DATA (FACTORY INSTALLED)				
MODEL NUMBER	NOMINAL COOLING (TONS)	STANDARD METERING DEVICE	COIL CONNECTION (LIQ. & SUCT.)	FILTER
12CLX	1.0 tons	TXV	3/8 I.D. / 5/8 I.D. (SWEAT)	18 X 24 X 1
24CLX	2.0 / 1.5 tons	TXV		18 X 24 X 1
25CLX	2.0 / 1.5 tons	TXV		20 X 25 X 1
36CLX	3.0 / 2.5 tons	TXV		20 X 25 X 1
37CLX	3.0 / 2.5 tons	TXV		25 x 25 x 1

DIMENSIONS										
UNIT MODEL	H	W	D	A	B	C	E	F	G	SHIP WT.
12CLX	27-3/8	22-3/8	24-3/8	15-7/8	19-1/4	16	12	2-3/8	7-3/4	110
24CLX	27-3/8	22-3/8	24-3/8	15-7/8	19-1/4	16	16	2-3/8	7-3/4	120
25/36CLX	29-3/8	26-3/8	26-3/8	18-3/8	22-3/8	18	16	3	7-3/4	130
37CLX	35-3/8	26-3/8	26-3/8	24-3/8	22-3/8	18	16	3	7-3/4	140

Drain Connections:
 Primary 3/4" MPT
 Secondary 3/4" OD Sweat

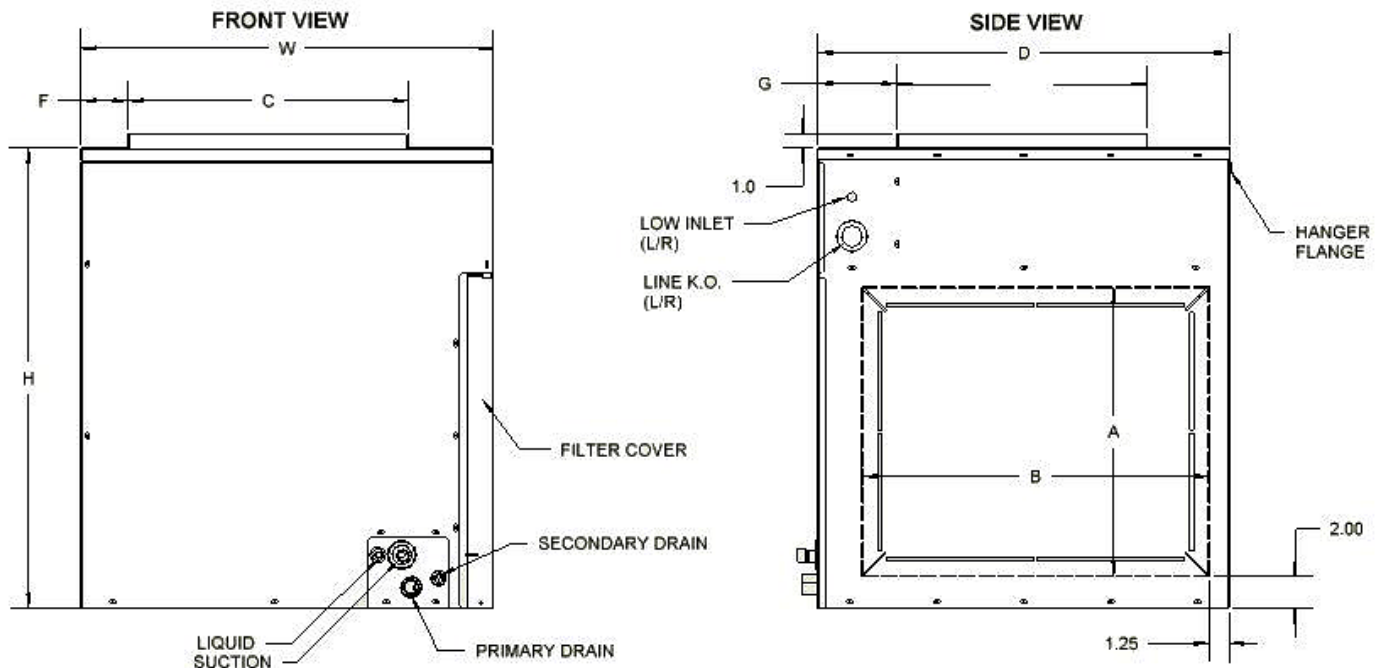

CL SERIES

CLXQ

HEAT PUMP OR DX W/STANDARD PUMP & ECM MOTOR

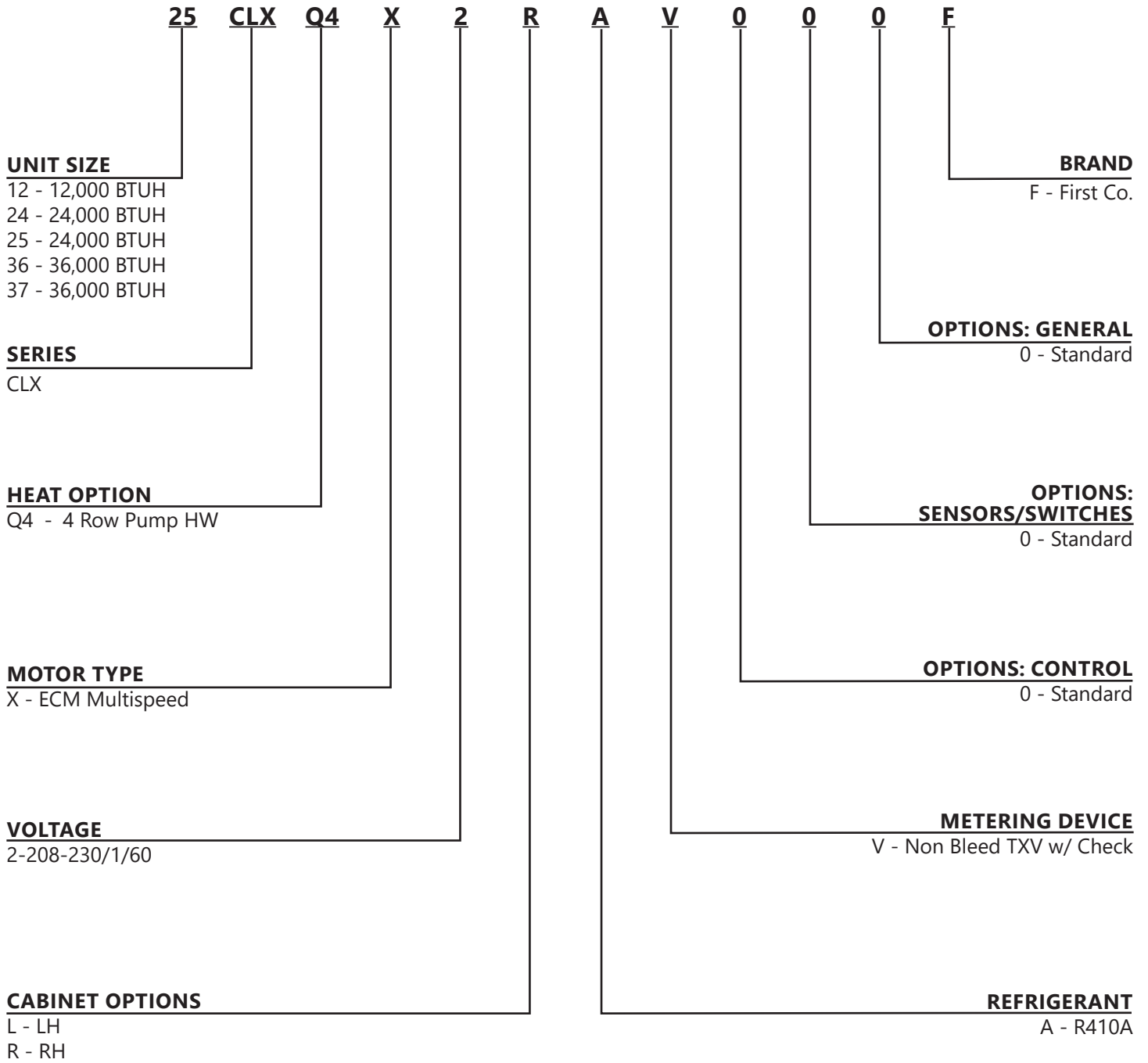

CL SERIES

HEAT PUMP OR DX W/STANDARD PUMP & ECM MOTOR

CLXQ

DATA TABLES

CLXQ

DIMENSIONS										
UNIT MODEL	H	W	D	A	B	C	E	F	G	SHIP WT.
12CLXQ	27-3/8	22-3/8	24-3/8	15-7/8	19-1/4	16	12	2-3/8	73/4	110 LBS.
24CLXQ	27-3/8	22-3/8	24-3/8	15-7/8	19-1/4	16	12	2-3/8	7-3/4	120 LBS.
25/36CLXQ	29-3/8	26-3/8	26-3/8	18-3/8	22-3/8	18	16	3	7-1/4	130 LBS.
37CLXQ	35-3/8	26-3/8	26-3/8	18-3/8	22-3/8	18	16	3	7-1/4	140 LBS.

BLOWER DATA												
UNIT MODEL	FAN SPEED TAP	AMP (120V)	MOTOR HP	CFM vs EXTERNAL STATIC PRESSURE								
				0.10	0.15	0.20	0.25	0.30	0.40	0.50		
12CLXQ	WHT	3.5	1/4	540	525	515	500	485	455	425		
	VIO			515	500	485	470	455	425	390		
	GRY			305	285	265	240	220	175	- - -		
24CLXQ	5	6.8	1/2	845	825	800	780	755	710	650		
	4			835	815	790	770	745	700	640		
	3			755	685	730	670	700	675	620		
	2			600	587	570	570	540	510	485		
25CLXQ	5			6.8	1/2	970	955	940	930	920	860	800
	4					820	805	790	775	760	720	690
	3					650	630	610	585	560	510	460
	2					550	525	500	475	450	400	350
36CLXQ	5	8.4	3/4			1270	1230	1195	1165	1135	1060	965
	4					1180	1160	1140	1116	1090	1035	940
	3					1040	1020	1005	985	965	925	890
	2					970	950	925	905	885	845	810
37CLXQ	5			8.4	3/4	1340	1320	1300	1285	1270	1250	1220
	4					1180	1165	1150	1130	1110	1090	1060
	3					1050	1030	1010	995	980	950	920
	2					930	915	900	880	860	820	760

ELECTRICAL DATA					
UNIT MODEL	MOTOR HP	AMPS		MIN. CIRCUIT AMPACITY	MAX. FUSE OR HACR BREAKER
		MOTOR	PUMP	120V	120V
12CLXQ	1/4	3.5	.75	5.0	15
24/25CLXQ	1/2	6.8	.75	10.0	15
36/37CLXQ	3/4	8.4	.75	12.0	15

COOLING COIL DATA (FACTORY INSTALLED)				
PRODUCT NUMBER	NOMINAL COOLING (TONS)	STANDARD METERING DEVICE	COIL CONNECTION (LIQ. & SUCT.)	FILTER
12CLXQ	1.0 tons	TXV	3/8 O.D. / 5/8 O.D. (SWEAT)	18 X 24 X 1
24CLXQ	2.0 / 1.5 tons	TXV		18 X 24 X 1
25CLXQ	2.0 / 1.5 tons	TXV		20 X 25 X 1
36CLXQ	3.0 / 2.5 tons	TXV		20 X 25 X 1
37CLXQ	3.0 / 2.5 tons	TXV		25 X 25 X 1

CLXQ (CONT'D)

HEATING PERFORMANCE					
UNIT MODEL	NOM. CFM	BTUH ENTERING WATER TEMPERATURE Delta-T 20°F and GPM			
		130°F	GPM	140°F	GPM
12CLXQ	275	14,500	1.5	16,900	2.0
	400	18,850	1.9	22,000	2.2
24CLXQ	600	25,700	2.6	30,000	3.0
	700	28,300	2.8	33,000	3.3
	800	30,800	3.1	36,000	3.6
25CLXQ	600	27,300	2.7	31,900	3.2
	700	30,500	3.1	45,600	4.6
	800	33,300	3.3	38,900	3.9
36/37CLXQ	1000	42,000	4.2	49,000	4.9
	1200	47,000	4.7	55,000	5.5

1. Heat BTUH is at 70°F entering air temperature.
2. Based on 20°F Delta-T. Velocity not to exceed 4ft./sec.

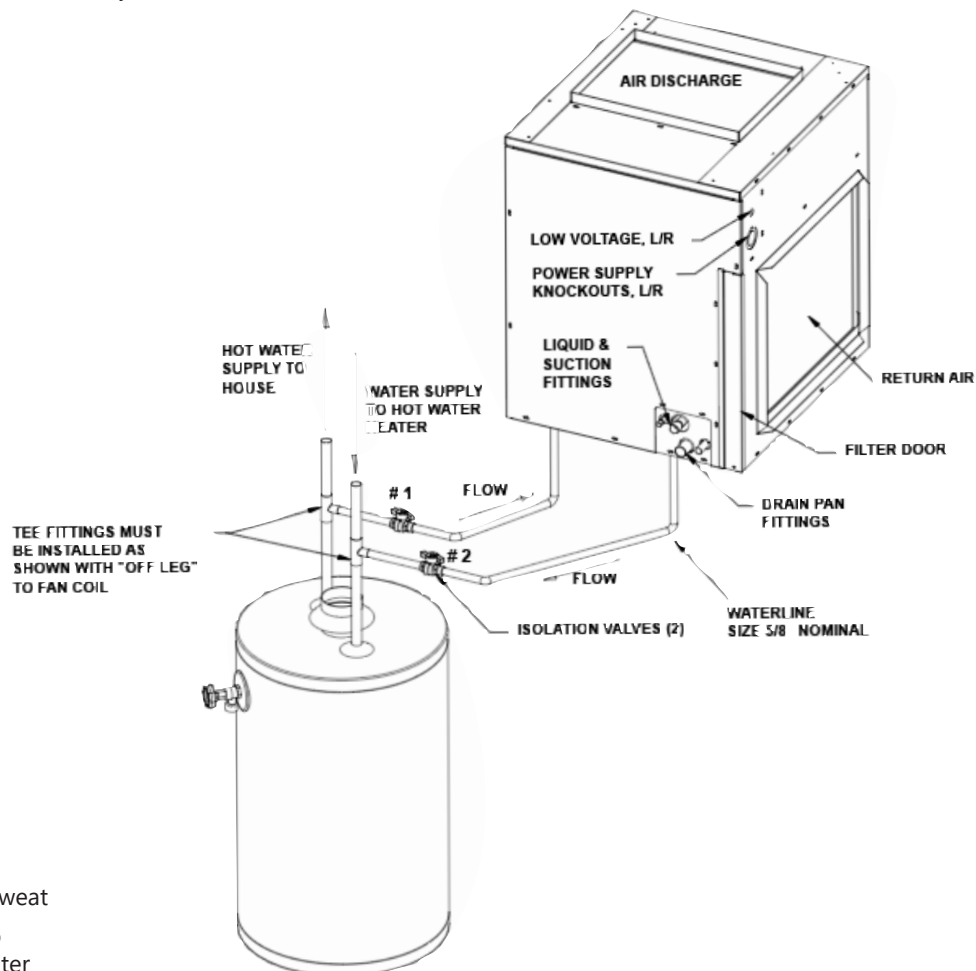

Drain Connections:
 Primary 3/4" MPT
 Secondary 3/4" OD Sweat
 Typical connection to
 Tank-Type Water Heater

CL SERIES

CLXW

HEAT PUMP OR DX W/HOT WATER COIL & ECM MOTOR

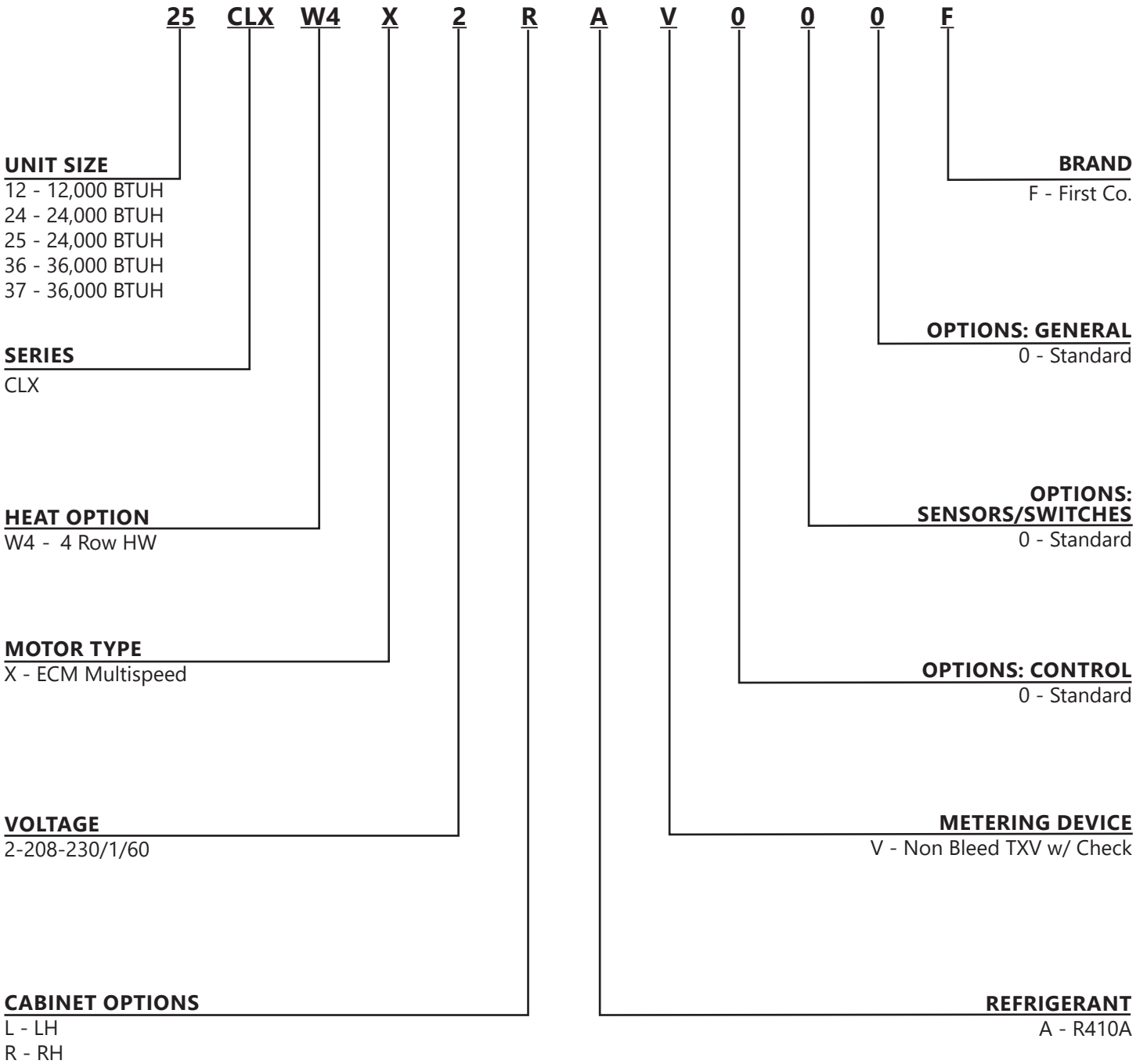

CL SERIES

HEAT PUMP OR DX W/HOT WATER COIL & ECM MOTOR

CLXW

DATA TABLES

CLXW

DIMENSIONS										
UNIT MODEL	H	W	D	A	B	C	E	F	G	SHIP WT.
12CLXW	27-3/8	22-3/8	24-3/8	15-7/8	20-1/2	16	12	2-3/8	7-3/4	110 LBS.
24CLXW	27-3/8	22-3/8	24-3/8	15-7/8	20-1/2	16	12	2-3/8	7-3/4	120 LBS.
25/36CLXW	29-3/8	26-3/8	26-3/8	18-3/8	23-2/8	18	16	3	7-1/4	130 LBS.
37CLXW	35-3/8	26-3/8	26-3/8	18-3/8	23-2/8	18	16	3	7-1/4	140 LBS.

ELECTRICAL DATA				
UNIT MODEL	MOTOR HP	AMPS	MIN. CIRCUIT AMPACITY	MAX. FUSE OR HACR BREAKER
		MOTOR	120V	120V
12CLXW	1/4	3.5	5.0	15
24/25CLXW	1/2	6.8	9.0	15
36/37CLXW	3/4	8.4	11.0	15

BLOWER DATA										
UNIT MODEL	FAN SPEED TAP	AMP (120V)	MOTOR HP	CFM VS EXTERNAL PRESSURE						
				0.1	0.15	0.2	0.25	0.3	0.4	0.5
12CLXW	WHT	3.5	1/4	540	525	515	500	485	455	425
	VIO			515	500	485	470	455	425	390
	GRY			305	285	265	240	220	175	-
24CLXW	5	6.8	1/2	845	825	800	780	755	710	650
	4			835	815	790	770	745	700	640
	3			755	685	730	670	700	675	620
	2			600	587	570	570	540	510	485
25CLXW	5	6.8	1/2	970	955	940	930	920	860	800
	4			820	805	790	775	760	720	690
	3			650	630	610	585	560	510	460
	2			550	525	500	475	450	400	350
36CLXW	5	8.4	3/4	1270	1230	1195	1165	1135	1060	965
	4			1180	1160	1140	1116	1090	1035	940
	3			1040	1020	1005	985	965	925	890
	2			970	950	925	905	885	845	810
37CLXW	5	8.4	3/4	1340	1320	1300	1285	1270	1250	1220
	4			1180	1165	1150	1130	1110	1090	1060
	3			1050	1030	1010	995	980	950	920
	2			930	915	900	880	860	820	760

CL SERIES

HEAT PUMP OR DX W/HOT WATER COIL & ECM MOTOR

CLXW

DATA TABLES

CLXW (CONT'D)

HEATING PERFORMANCE					
UNIT MODEL	NOM. CFM	BTUH ENTERING WATER TEMPERATURE Delta-T 20°F and GPM			
		130° F	GPM	140°F	GPM
12CLXW	275	14,500	1.5	16,900	1.7
	400	18,850	1.9	22,000	2.2
24CLXW	600	25,700	2.6	30,000	3.0
	700	28,300	2.8	33,000	3.3
	800	30,800	3.1	36,000	3.6
25CLXW	600	27,300	2.7	31,900	3.2
	700	30,500	3.1	45,600	4.6
	800	33,300	3.3	38,900	3.9
36/37CLXW	1000	42,000	4.2	49,000	4.9
	1200	47,000	4.7	55,000	5.5

1. Heat BTUH is at 70°F entering air temperature.
2. Based on 20°F Delta-T. Velocity not to exceed 4ft./sec.

COOLING COIL DATA (FACTORY INSTALLED)				
PRODUCT NUMBER	NOMINAL COOLING (TONS)	STANDARD METERING DEVICE	COIL CONNECTION (LIQ. & SUCT.)	FILTER
12CLXW	1.0 tons	TXV	3/8 O.D. / 5/8 O.D. (SWEAT)	18 X 24 X 1
24CLXW	2.0 / 1.5 tons	TXV		18 X 24 X 1
25CLXW	2.0 / 1.5 tons	TXV		20 X 25 X 1
36CLXW	3.0 / 2.5 tons	TXV		20 X 25 X 1
37CLXW	3.0 / 2.5 tons	TXV		25 X 25 X 1

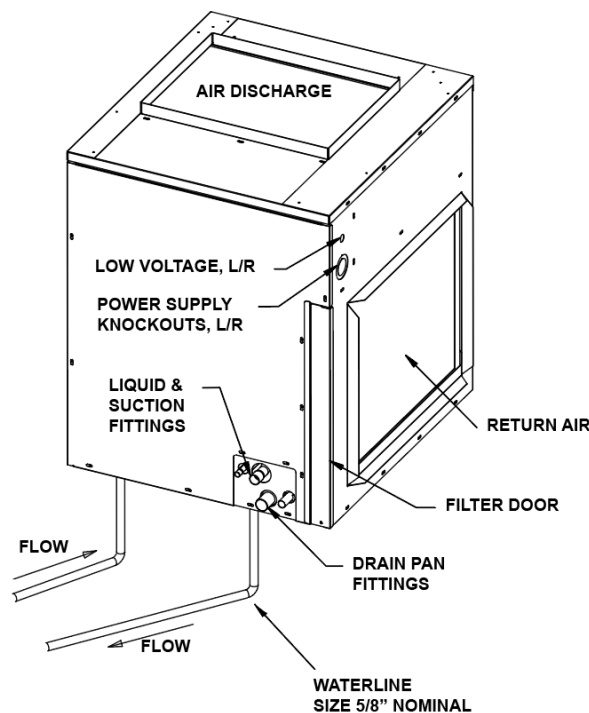

WARNING AVERTISSEMENT ADVERTENCIA
 Cancer and Reproductive Harm
 Cancer et Troubles de l'appareil reproducteur
 Cáncer y Daño Reproductivo
www.P65Warnings.ca.gov LBY0067



AMERICAN-MADE. FAMILY OWNED.



FIRST CO.
P.O. BOX 270969 - DALLAS, TEXAS 75227
PH. (214) 388-5751 | FAX (214) 388-2255
WWW.FIRSTCO.COM

MARCH 2025