



AQUA-PAK

Space Constrained Vertical Unit
Cooling with Hot Water Heat

3/4 – 2.5 Tons

Up to 47,800 BTUH Heating

11.7 SEER2

R454B



TABLE OF CONTENTS

NOMENCLATURE	3
PRODUCT DESCRIPTION	4
FEATURES	6-8
ACCESSORIES	9-10
DIMENSIONS	11-12
BLOWER & COOLING PERFORMANCE	13
HOT WATER HEATING	14-15
ELECTRICAL DATA	16
GENERAL ASSEMBLY SLEEVES & LOUVERS	17-18
CLOSET DIMENSIONS.....	19

To determine certified indoor/outdoor combinations, go to www.firstco.com or contact the factory.

In keeping with its policy of continuous progress and product improvement, First Co. reserves the right to make changes without notice.

NOMENCLATURE

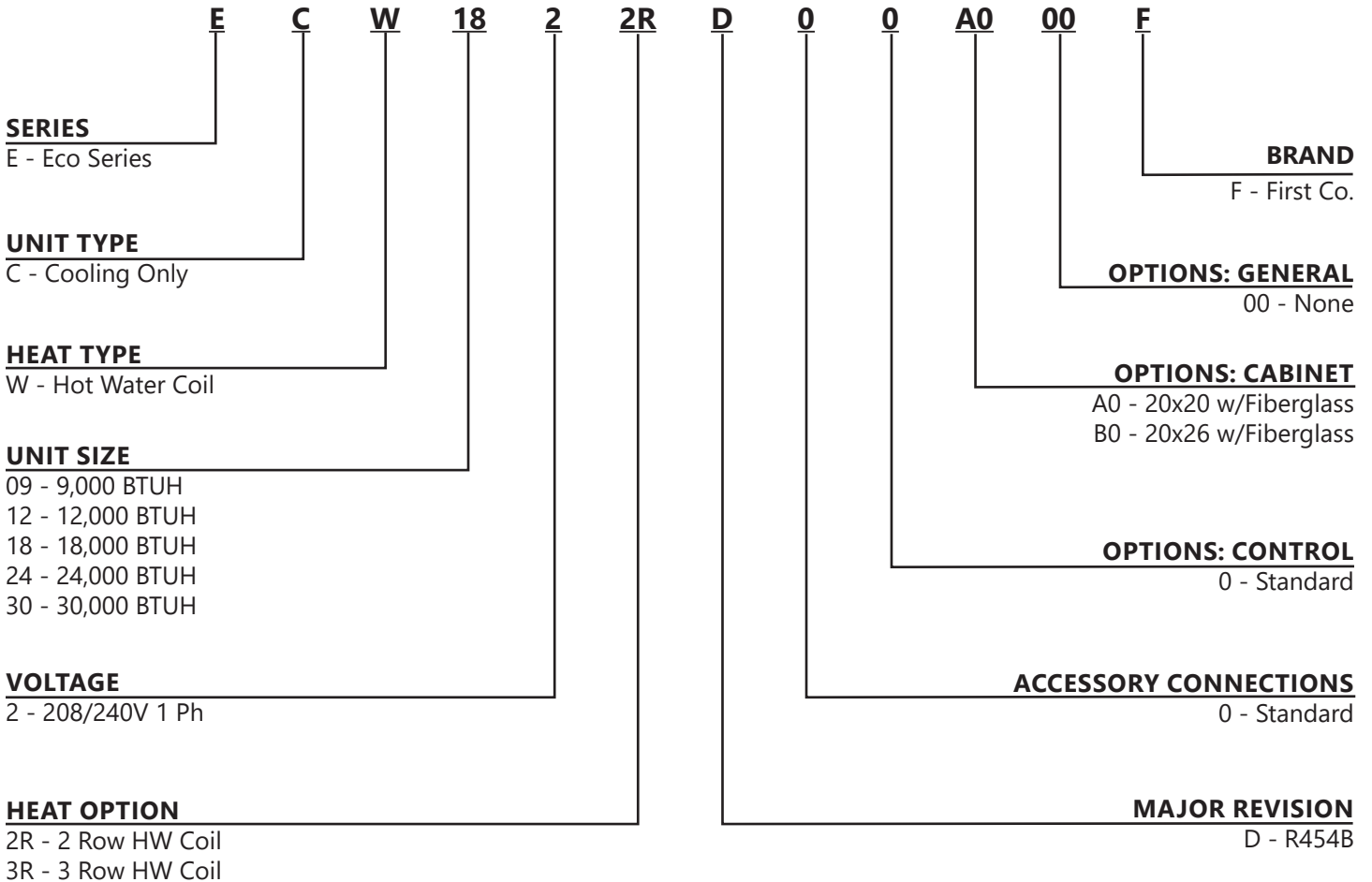

ECO SERIES AQUA-PAK

SPACE CONSTRAINED VERTICAL UNIT

PRODUCT DESCRIPTION

- Space constrained electric cooling with hot water heating
- Pre-wired and pre-charged with R-454B refrigerant, capable of delivering conditioned air to multiple rooms
- Easily installs into a closet or mechanical room on an exterior wall, utilizing a minimal amount of floor space
- Controlled by a standard low voltage thermostat with high and low temperature limits

APPLICATIONS

Hospitality, Apartments/Condominiums, Assisted Living/Memory Care, Student Housing, Senior Living and Modular/Prefabricated Buildings.

STANDARD FEATURES

- Completely pre-charged with environmentally friendly R-454B refrigerant
- Easy access for in-place service of most components
- Multi-function micro-processor board that includes the following functions:
 - Evaporator coil low temperature protection
 - Low ambient lockout
 - ECM motor utilized on all models
 - Random restart
 - Compressor restart delay
 - Fan-off delay in the cooling mode
 - Low voltage fuse protection
- Service disconnect
- Completely insulated cabinet for sound attenuation and weather infiltration
- Adjustable fresh air damper
- No tool needed to replace the filter
- Weight-supporting, single piece wall sleeves (except side access sleeves) for various wall thicknesses from 5" to 20"
- Sleeves have primary condensate drain connection with secondary overflow to building exterior
- All sleeves are shipped with a weather guard
- Units charged with over 4lbs of refrigerant have factory installed leak mitigation sensors

SERVICEABILITY FEATURES

- Easy access for in-place service of most components
- All electrical components and control boards are serviceable from front of the unit

LIMITED WARRANTY

5 Years Compressor, 5 Years parts

REQUIRED ACCESSORIES

- Weight bearing wall sleeves for various wall thicknesses from 5" to 20" shipped with weather and debris guard
- Wall sleeves have primary condensate drain connection with secondary overflow to building exterior
- Flush type aluminum louver with finish and paint options
- Standard low voltage thermostat with high and low temperature limits

ECO SERIES AQUA-PAK

SPACE CONSTRAINED VERTICAL UNIT

OPTIONAL ACCESSORIES

CUSTOM COLOR LOUVERS

STANDARD PAINT COLORS

 <p>SLATE BLUE (LF01)</p>	 <p>MEDIUM BRONZE (LF02)</p>	 <p>SANDSTONE (LF03)</p>
 <p>LIGHT GRAY (LF04)</p>	 <p>CHARCOAL (LF05)</p>	 <p>BONE WHITE (LF06)</p>
 <p>WESTERN TAN (LF07)</p>	 <p>ARCHITECTURAL BRONZE (LF08)</p>	 <p>REGAL BLUE (LF09)</p>
 <p>FOREST GREEN (LF10)</p>	 <p>SURREY BEIGE (LF11)</p>	 <p>ROYAL BROWN (LF12)</p>
 <p>BARN RED (LF13)</p>	 <p>BURGUNDY (LF14)</p>	 <p>CLAY (LF15)</p>
 <p>ALMOND (LF16)</p>	 <p>COASTAL WHITE (LF17)</p>	 <p>VISTA GREEN (LF18)</p>
 <p>BLACK (LF19)</p>	 <p>GLOSS BLACK (LF20)</p>	 <p>CAMPUS GREEN (LF21)</p>

Custom color options available

ECO SERIES AQUA-PAK

SPACE CONSTRAINED VERTICAL UNIT

STANDARD UNIT FEATURES

FILTER RACK

Filter Brackets and a disposable filter ship with each unit to be field installed over the evaporator coil.

NOTE: Do not use filters which will cause the total external static pressure including ducts, louvers, registers, and filters to exceed 0.5 in. H₂O.

MULTI-FUNCTION MICROPROCESSOR CONTROL BOARD

Evaporator coil low temperature protection – During the cooling mode, should the evaporator coil experience either a low temperature condition that could result in ice buildup on the coil or a reduced air flow situation, a temperature sensor attached to the coil will de-energize the unit. The sensor will re-energize the unit when the coil warms back up.

Random restart – A built-in, random restart of between three to four minutes which prevents all compressors from restarting simultaneously when power is restored after an outage.

Compressor restart delay – Ensures system pressures are allowed to equalize prior to compressor restart, extending compressor life.

Fan delay – A fan delay allows the evaporator blower to continue running for up to 45 seconds after the thermostat is satisfied, which maximizes cooling performance.

Low voltage fuse protection - Disconnects the live circuit when the current exceeds a predetermined value.



Closet Location

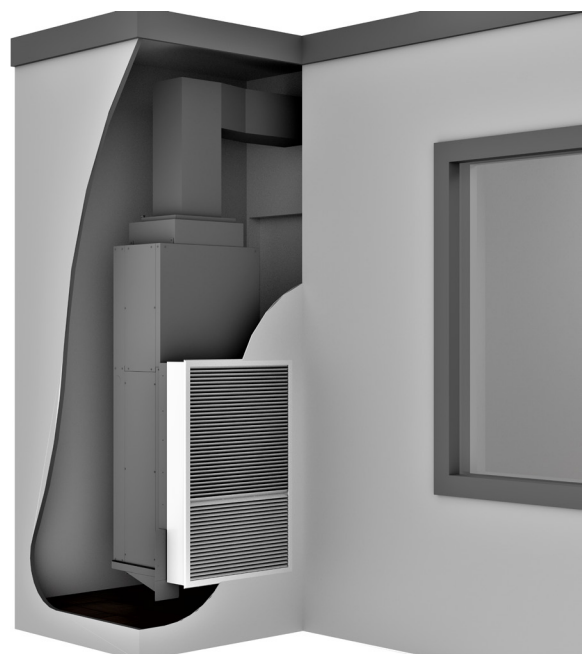

Exterior Location

ECO SERIES AQUA-PAK

SPACE CONSTRAINED VERTICAL UNIT

VENTILATION AIR

One end of a 3" aluminum vent pipe is connected to the condenser venturi and the other end is connected to the side of the cabinet. A mesh screen and a metal plate on the side of the cabinet covers the opening of the vent pipe.

Up to 50 CFM of ventilation air is introduced into the equipment closet by removing the metal cover plate. The ventilation air mixes with the return air and is then pulled through the evaporator coil and into the supply duct. The cover plate can be reinstalled to partially close the ventilation air opening if less than 50 CFM is desired. An external source of negative pressure (i.e. a bathroom fan) could be used to introduce more than 50 CFM of ventilation air. Consult with factory for further details.

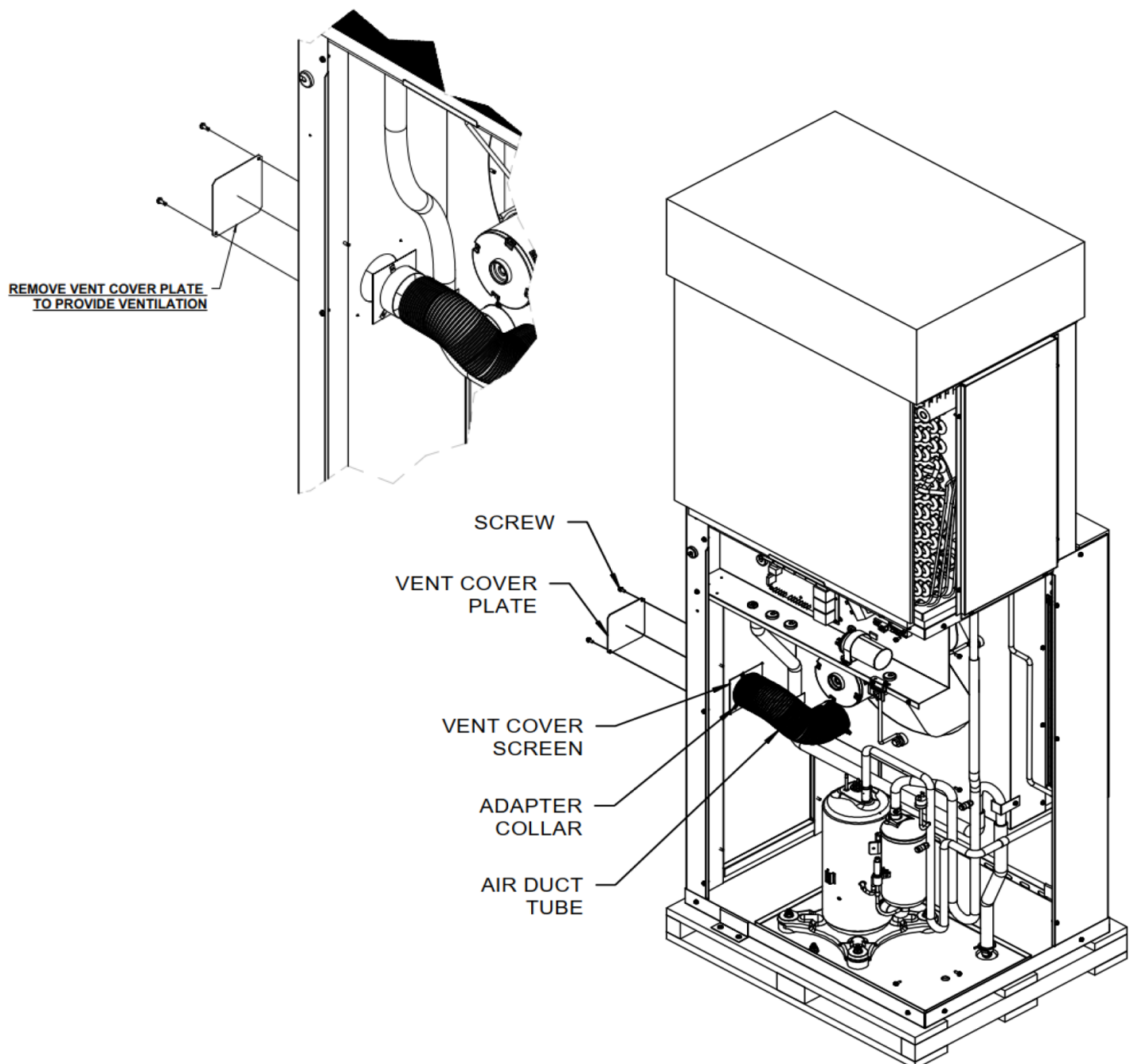

ECO SERIES AQUA-PAK

SPACE CONSTRAINED VERTICAL UNIT

CONDENSATE SYSTEM

Primary Condensate

Factory installed drain line connects the evaporator drain pan to a vertical pipe connection in the unit base pan. Evaporator condensate is delivered from the unit to a catch tray in the wall sleeve and exits the sleeve through the 3/4" male NPT fitting. This design allows the plumber to completely pipe the drain to a condensate riser during the rough-in stage, thus eliminating condensate connection problems usually encountered when trying to connect the HVAC drain to the riser after the HVAC unit is installed in the closet. This feature also allows the unit to be removed for service without disconnecting the condensate piping. This configuration does not require any additional closet space to make the drain connection, as do some competitive products.

Secondary Condensate Overflow

If for any reason the primary condensate riser becomes clogged, water will fill the catch tray and then be diverted through the sleeve to the exterior of the building, rather than be allowed to overflow into the closet or living area. Rain water entering the sleeve is automatically diverted to the 3/4" condensate drain.

REQUIRED ACCESSORIES: WALL SLEEVES

- Provided for installation during rough-in and when ready the unit is simply slid into the wall sleeve and connected to the ductwork and electrical
- Weight bearing sleeve that supports the entire weight of the unit and provides a weather tight seal against wind and water infiltration
- Four wall sleeve depths are available to accommodate wall thickness from 5" to 20"
- Includes a weather guard to cover the sleeve opening and a debris guard to cover wall sleeve base and drain during construction

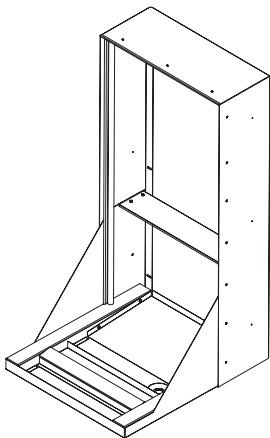

Standard Sleeve
for 3/4 - 2 tons

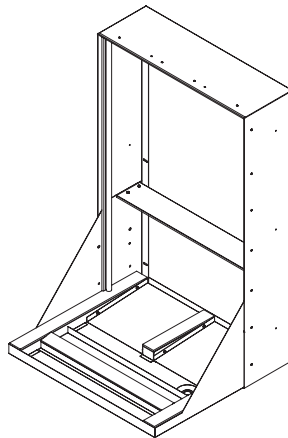

Standard Sleeve
for 2.0 - 2.5 tons

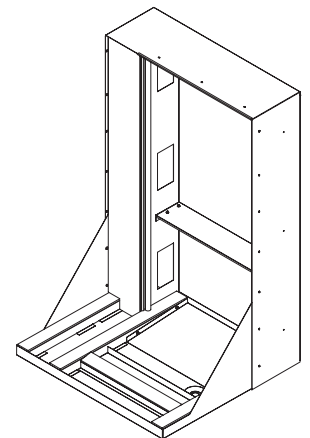

Oversized Sleeve
for 3/4 - 2 tons to provide
uniform exterior appearance

ECO SERIES AQUA-PAK



SPACE CONSTRAINED VERTICAL UNIT

ACCESSORIES

SLEEVE AND LOUVER ACCESSORIES						
ACCESSORY	DESCRIPTION	DIMENSIONS (H x W x D)	STANDARD SLEEVES		SHIP WT. (EA) Lbs.	
			REAR INSTALL ¹	SIDE INSTALL ²	REAR ⁵	SIDE ⁵
SMALL CABINET "A" WALL SLEEVES	For 5" - 8" thick walls	43-3/4 x 21-3/8 x 26	936-1B	936-11B	59	64
	For 8" - 12" thick walls	43-3/4 x 21-3/8 x 30	936-2B	936-12B	63	73
	For 12" - 15" thick walls	43-3/4 x 21-3/8 x 33	936-3B	936-13B	68	73
	For 15" - 20" thick walls	43-3/4 x 21-3/8 x 38	936-4B	936-14B	75	80
LARGE CABINET "B" WALL SLEEVES	For 5" - 8" thick walls	43-3/4 x 27-3/8 x 26	985-1B	985-11B	63	68
	For 8" - 12" thick walls	43-3/4 x 27-3/8 x 30	985-2B	985-12B	68	73
	For 12" - 15" thick walls	43-3/4 x 27-3/8 x 33	985-3B	985-13B	75	80
	For 15" - 20" thick walls	43-3/4 x 27-3/8 x 38	985-4B	985-14B	79	84
SMALL CABINET "A" LARGE WALL SLEEVES WITH BLOCKOFF	For 5" - 8" thick walls	43-3/4 x 27-3/8 x 26	986-1B	986-11B	63	68
	For 8" - 12" thick walls	43-3/4 x 27-3/8 x 30	986-2B	986-12B	68	73
	For 12" - 15" thick walls	43-3/4 x 27-3/8 x 33	986-3B	986-13B	75	80
	For 15" - 20" thick walls	43-3/4 x 27-3/8 x 38	986-4B	986-14B	79	84
STANDARD LOUVERS CABINET "A" WALL SLEEVES	Custom Painting	44x22	G205S		12	
	For Field Painting	44x22	G205PPA		12	
	Anodized Aluminum	44x22	G205A		12	
STANDARD LOUVERS CABINET "B" LARGE WALL SLEEVES	Custom Painting	44x28	G216S		18	
	For Field Painting	44x28	G216PPA		18	
	Anodized Aluminum	44x28	G216A		18	

NOTES:

1. Rear install application provides better access to the unit and is recommended over side install wherever possible.
2. Side install application requires different closet size and configuration. Contact factory for further information.
3. Wind resistant sleeves require the usage of a wind resistant louver.
4. S indicates custom color, to be provided by customer. Minimum order quantity is 15 per color, if less than 15 set up fees will be applied.
5. All wall sleeves are shipped two (2) per carton, fully assembled.

THERMOSTATS			
Straight Cool (24V) Digital cool - off - heat, auto - on w/limits-(6-wire)	4 x 5 (Horizontal)	T1220NC	
Programmable (5-2) St. Cool/Ht. Pump (24V) cool-off-heat, auto-on w/em. Ht. & limits (6-wire)	4 x 5 (Horizontal)	T2220NC	
Straight Cool or Heat Pump (24V) Digital Occupancy Sensor	4.3 x 5.7 (Horizontal)	T8532	

ECO SERIES AQUA-PAK

SPACE CONSTRAINED VERTICAL UNIT

ACCESSORIES (CONT'D)

OPTIONAL ACCESSORIES (FIELD INSTALLED)						
COMPONENT	DESCRIPTION	DIMENSIONS (H X W)		PART NUMBER	SHIPPING WEIGHT	EQUIPPED WITH FILTER
		FRAME	OPENING			
ACCESS/RETURN AIR PANEL (3)(4)	LOUVERED (1)	87 X 31	84 X 28	931-11	55	20 x 24 x 1
	NON-LOUVERED (2)	87 X 31	84 X 28	931-12		NO
	LOUVERED (1)	82 X 31	79 X 28	931-13		20 x 24 x 1
	NON-LOUVERED (2)	82 X 31	79 X 28	931-14		NO
ACCESS/RETURN AIR PANEL (3)(4)	LOUVERED (1)	87 X 37	84 X 34	931-15	55	20 x 24 x 1
	NON-LOUVERED (2)	87 X 37	84 X 34	931-16		NO
	LOUVERED (1)	82 X 37	79 X 34	931-17		20 x 24 x 1
	NON-LOUVERED (2)	82 X 37	79 X 34	931-18		NO
9-24A INSULATION KIT	5/8" DUCTBOARD	N/A		91K01	---	---
24B-30 INSULATION KIT				91K02	---	---

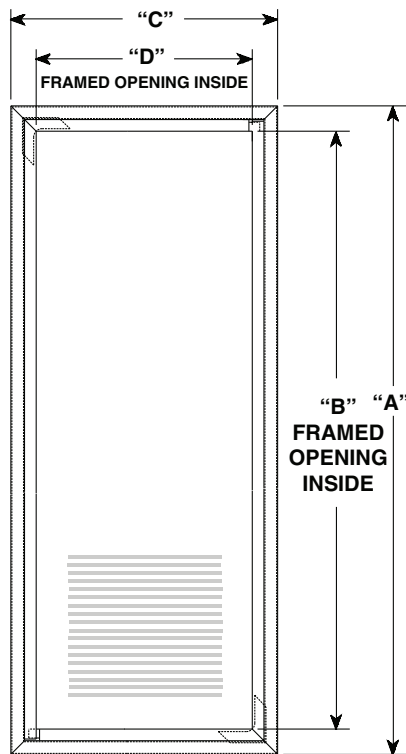

* For rear installation use with size 24B or 30

NOTE: A solid door or panel with a side wall return air louver will result in lower sound levels.

NOTES:

- (1) Includes 18 x 24 x 1 or 20 x 24 x 1 filter.
- (2) Requires external return air louver and unit mount filter.
- (3) Both panels are insulated for sound reduction and have tamperproof screws.
- (4) Panels are shipped ten per carton.

PART NO.	"A"	"B"	"C"	"D"
931-11(12)	87.00	84.00	31.00	28.00
931-13(14)	82.00	79.00	31.00	28.00
*931-15(16)	87.00	84.00	37.00	34.00
*931-17(18)	82.00	79.00	37.00	34.00

ECO SERIES AQUA-PAK

SPACE CONSTRAINED VERTICAL UNIT

PHYSICAL DATA

UNIT DIMENSIONS

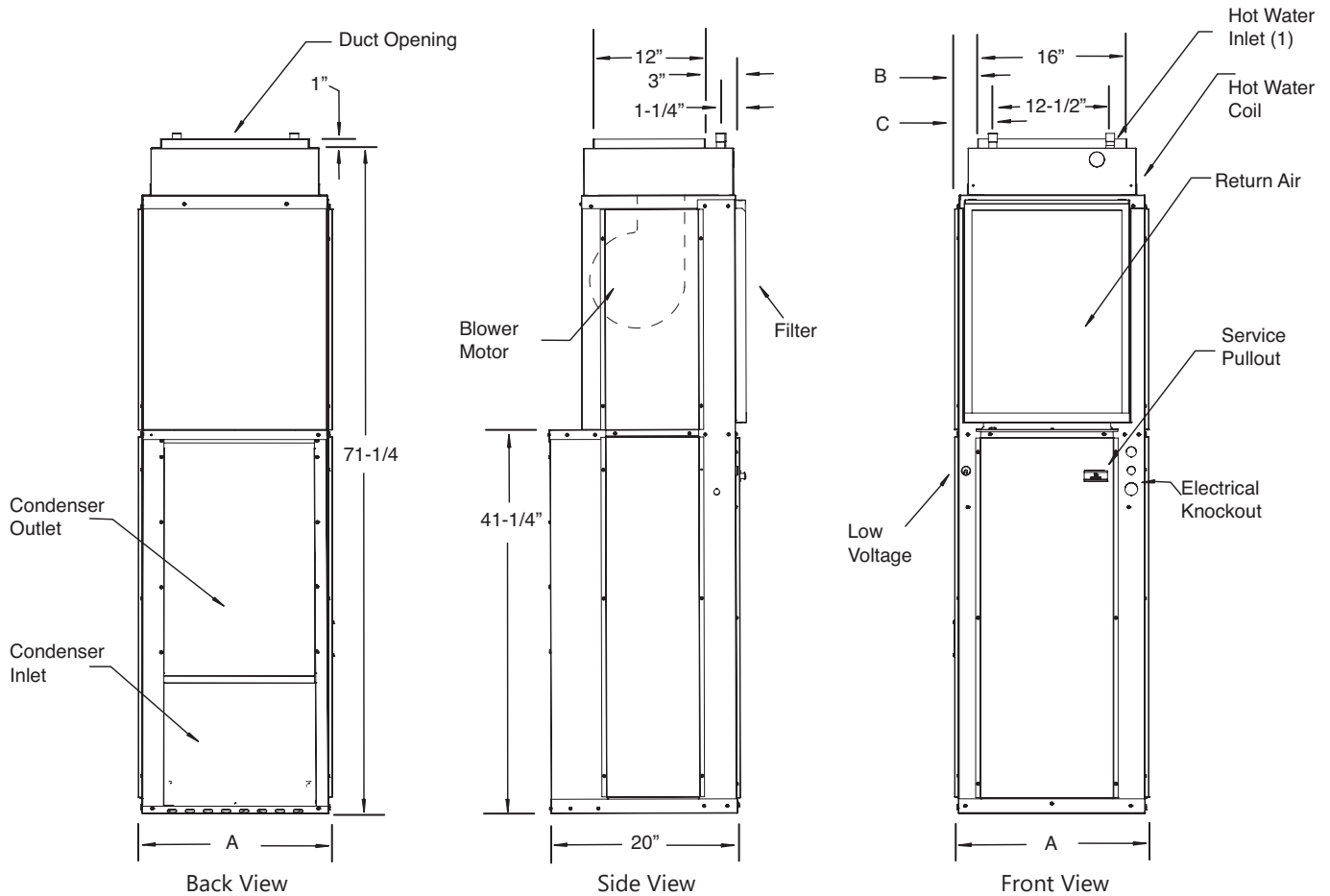

AQUA-PAK DIMENSIONS				
UNIT	A	B	C	FILTER
9,12,18, 24A	20	2	3-3/4	18 x 24 x 1
24B ,30	26	5	6-3/4	24 x 24 x 1

(1) Hot water coil connections are 7/8" O.D., Sweat

ECO SERIES AQUA-PAK

SPACE CONSTRAINED VERTICAL UNIT

DATA TABLES

PHYSICAL DATA						
454B COOL PAK AC	ECW09	ECW12	ECW18	ECW24B	ECW24A	ECW30
Compressor (Quantity)	Rotary (1)				Scroll (2 stage)	Scroll (1)
Compressor FLA	3.8	4.7	7.5	10.2	9.7	11.7
Factory Charge (R454B)	Lb	2.5	3.0	3.9	5.4	5.4
	kg	1.13	1.36	1.76	2.43	2.44
Minimum Room Area	m ²	3.41	4.11	5.32	7.34	7.37
	Ft ²	37	44	57	79	79
Minimum Air Flow	CFM	67	81	105	145	146
	M ³ /hr	115	138	178	246	247
ID MOTOR						
Motor (Quantity)	1	1	1	1	1	1
Fan Motor Type	ECM	ECM	ECM	ECM	ECM	ECM
Motor HP	1/4	1/4	1/3	1/3	1/3	1/2
Motor FLA	2.3	2.3	2.8	2.8	2.8	4.1
OD MOTOR						
Motor (Quantity)	1	1	1	1	1	1
Fan Motor Type	ECM	ECM	ECM	ECM	ECM	ECM
Motor HP	1/4	1/4	1/4	1/4	1/4	1/3
Motor FLA	2.3	2.3	2.3	2.3	2.3	2.8
ID BLOWER						
Blowers (Quantity)	1	1	1	1	1	1
Blower Wheel Size (D x W) in. [cm]	6 x 7	6 x 7	9 x 4	9 x 4	9 x 4	9 x 4
	[15.3 x 17.78]	[15.3 x 17.78]	[22.9 x 10.16]	[22.9 x 10.16]	[22.9 x 10.16]	[22.9 x 10.16]
EVAPORATOR COIL						
Dimensions (H x W) in. [cm]	24 x 16.25	24 x 16.25	24 x 16.25	24x22	24 x 16.25	24x22
	[61 x 41.275]	[61 x 41.275]	[61 x 41.275]	[61 x 55.88]	[61 x 41.275]	[61 x 55.88]
Face Area ft ² [m ²]	3.53 [2.70]	3.53 [2.70]	3.53 [2.70]	3.67 [0.34]	3.53 [2.70]	3.67 [0.34]
Rows	2	3	4	4	4	4
OD COIL						
Dimensions (H x W) in. [cm]	26 x 16.5	26 x 16.5	26 x 16.5	26 x 22.5	26 x 16.5	26 x 22.5
	[66 x 42]	[66 x 42]	[66 x 42]	[66 x 57]	[66 x 42]	[66 x 57]
Face Area ft ² [m ²]	3.0 [0.2772]	3.0 [0.2772]	3.0 [0.2772]	4.1 [0.3762]	3.0 [0.2772]	4.1 [0.3762]
Rows	2	3	4	4	4	4
MISCELLANEOUS						
Throwaway Filter Dim. in. [cm]	18 x 24	18 x 24	18 x 24	24 x 24	18 x 24	24 x 24
	[45.72 x 60.96]	[45.72 x 60.96]	[45.72 x 60.96]	[60.96 x 60.96]	[45.72 x 60.96]	[60.96 x 60.96]
Throwaway Filter Quantity	1	1	1	1	1	1
A2L Mitigation	NO	NO	NO	YES	YES	YES
Operating Weight lb. [kg]	288 [131]	289[131]	290 [131]	305 [138]	290 [131]	315 [142]
Packaged Weight lb. [kg]	310 [141]	310[141]	310[141]	325[147]	310[141]	335 [152]

ECO SERIES AQUA-PAK

SPACE CONSTRAINED VERTICAL UNIT

BLOWER PERFORMANCE

AQUA-PAK BLOWER PERFORMANCE												
MODEL	Motor Tap	Motor Speed	IWC STATIC PRESSURE									
			0.10		0.20		0.30		0.40		0.50	
			SCFM	W	SCFM	W	SCFM	W	SCFM	W	SCFM	W
ECW0922RA	1	T1 ^H	322	62	303	62	285	61	266	58	243	54
	2	T2 ^C	359	75	340	75	322	74	302	72	280	67
ECW122RA	1	T1 ^H	423	101	404	101	385	100	366	97	343	93
	2	T2 ^C	455	117	436	116	418	115	398	113	376	108
ECW1822RA	1	T1 ^H	633	136	601	132	558	123	509	117	470	123
	2	T2 ^C	728	184	697	180	653	172	604	165	566	172
ECW1823RA	1	T1 ^H	633	136	601	132	558	123	509	117	470	123
	2	T2 ^C	728	184	697	180	653	172	604	165	566	172
ECW2422RA	1	T1 ^H	858	247	825	244	787	240	738	233	672	221
	2	T2 ^{C low}	682	144	649	142	611	137	562	130	495	119
	4	T4 ^{C high}	905	289	872	287	834	282	785	275	718	264
ECW2423RA	1	T1 ^H	858	247	825	244	787	240	738	233	672	221
	2	T2 ^{C low}	682	144	649	142	611	137	562	130	495	119
	4	T4 ^{C high}	905	289	872	287	834	282	785	275	718	264
ECW2422RB	1	T1 ^H	841	231	818	237	798	244	779	251	759	255
	2	T2 ^C	910	277	888	284	867	290	848	297	829	302
ECW2423RB	1	T1 ^H	841	231	818	237	798	244	779	251	759	255
	2	T2 ^C	910	277	888	284	867	290	848	297	829	302
ECW3022RB	1	T1 ^H	926	295	896	289	866	283	836	276	803	268
	2	T2 ^C	1013	362	983	356	953	350	923	343	890	335
ECW3023RB	1	T1 ^H	926	295	896	289	866	283	836	276	803	268
	2	T2 ^C	1013	362	983	356	953	350	923	343	890	335

^C Factory Default Cooling

^H Factory Default Heating

Blower performance data based on a dry coil at 70°F DB EAT with a standard 1" clean air filter.

Data is subject to change. Please verify most current information on www.firstco.com.

RATED COOLING PERFORMANCE

MODEL	Rated Airflow SCFM	Cooling Capacity 95°F, BTUH	EER2 95°F	SEER2
ECW09***D	300	9000	10.0	11.7
ECW12***D	400	11400	10.0	11.7
ECW18***D	600	17500	10.0	11.7
ECW24A***D	800/600	23400	10.0	11.7
ECW24B***D	800	23500	10.0	11.7
ECW30***D	950	26500	10.0	11.7

(1) Tested at 95°F DB/75°F WB outdoor and 80°F DB/67°F WB indoor.

Data is subject to change. Please verify most current information on www.firstco.com.

ECO SERIES AQUA-PAK

SPACE CONSTRAINED VERTICAL UNIT

HOT WATER HEATING

AQUA-PAK HW HEATING DATA						
MODEL	Airflow (CFM)	GPM	P.D. (FT. WATER)	BTUH (1,000) @ Entering Water Temperature		
				120°F	140°F	180°F
ECW0922RA*	375	4	3.2	10.7	14.9	23.5
		3	1.9	10.3	14.5	22.7
		2	0.9	9.7	13.6	21.4
	300	4	3.2	9.3	13.0	20.5
		3	1.9	9.0	12.7	19.9
		2	0.9	8.6	12.0	18.9
ECW1222RA*	410	4	3.2	11.3	15.8	24.8
		3	1.9	10.9	15.2	23.9
		2	0.9	10.2	14.3	22.5
	330	4	3.2	9.9	13.8	21.7
		3	1.9	9.6	13.4	21.1
		2	0.9	9.1	12.7	20.0
ECW1823RA*	780	4	3.2	16.4	22.9	36.0
		3	1.9	15.7	22.0	34.6
		2	0.9	14.6	20.4	32.0
	690	4	3.2	15.3	21.4	33.6
		3	1.9	14.7	20.6	32.4
		2	0.9	13.6	19.1	30.0
ECW1823RA*	760	4	4.7	21.1	29.5	46.3
		3	2.7	20.2	28.3	44.5
		2	1.3	18.8	26.3	41.3
	680	4	4.7	19.7	27.6	43.4
		3	2.7	18.9	26.5	41.6
		2	1.3	17.6	24.7	38.8
ECW2422RA*	820	4	3.2	16.9	23.7	37.2
		3	1.9	16.2	22.6	35.6
		2	0.9	15.0	20.9	32.9
	590	4	3.2	14.4	20.2	31.7
		3	1.9	13.9	19.4	30.5
		2	0.9	13.0	18.1	28.5
ECW2423RA*	800	4	4.7	21.9	30.6	48.1
		3	2.7	20.9	29.3	46.0
		2	1.3	19.4	27.1	42.6
	580	4	4.7	18.3	25.6	40.2
		3	2.7	17.6	24.6	38.7
		2	1.3	16.4	23.0	36.2

ECO SERIES AQUA-PAK

SPACE CONSTRAINED VERTICAL UNIT

HOT WATER HEATING (CONT'D)

AQUA-PAK HW HEATING DATA						
MODEL	Airflow (CFM)	GPM	P.D. (FT. WATER)	BTUH (1,000) @ Entering Water Temperature		
				120°F	140°F	180°F
ECW2422RB*	820	4	3.2	16.9	23.7	37.2
		3	1.9	16.2	22.6	35.6
		2	0.9	15.0	20.9	32.9
	590	4	3.2	14.4	20.2	31.7
		3	1.9	13.9	19.4	30.5
		2	0.9	13.0	18.1	28.5
ECW2423RB*	800	4	4.7	21.9	30.6	48.1
		3	2.7	20.9	29.3	46.0
		2	1.3	19.4	27.1	42.6
	580	4	4.7	18.3	25.6	40.2
		3	2.7	17.6	24.6	38.7
		2	1.3	16.4	23.0	36.2
ECW3022RB*	840	4	3.2	17.0	23.8	37.4
		3	1.9	16.3	22.8	35.8
		2	0.9	15.7	21.9	34.5
	720	4	3.2	17.0	23.8	37.4
		3	1.9	15.0	21.0	33.1
		2	0.9	14.0	19.5	30.7
ECW3023RB*	810	4	4.7	21.9	30.6	48.1
		3	2.7	20.9	29.3	46.0
		2	1.3	19.4	27.1	42.6
	690	4	4.7	19.9	27.9	43.8
		3	2.7	19.1	26.7	42.0
		2	1.3	17.8	24.9	39.1

ECO SERIES AQUA-PAK

SPACE CONSTRAINED VERTICAL UNIT

ELECTRICAL DATA

AQUA-PAK ELECTRICAL DATA											
Model	Voltage	COMPRESSOR		OUTDOOR MOTOR		INDOOR MOTOR		MIN. CIRCUIT AMPACITY (MCA) CIRCUIT 1 (L1-L2)		MAX. OVERCURRENT PROTECTION (MOP) CIRCUIT 1 (L1-L2)	
		RLA	LRA	FLA	HP	FLA	HP	240V	208V	240V	208V
ECW0922RD00A*	208/240-1-60	4	22	2.3	1/4	2.3	1/4	11	11	15	15
ECW1222RD00A*	208/240-1-60	4.6	25	2.3	1/4	2.3	1/4	12	12	15	15
ECW1822RD00A*	208/240-1-60	7.6	36	2.3	1/4	2.8	1/3	16	16	20	20
ECW1823RD00A*	208/240-1-60	7.6	36	2.3	1/4	2.8	1/3	16	16	20	20
ECW2422RD00A*	208/240-1-60	10.2	58	2.3	1/4	2.8	1/3	20	20	25	25
ECW2423RD00A*	208/240-1-60	10.2	58	2.3	1/4	2.8	1/3	20	20	25	25
ECW2422RD00B*	208/240-1-60	10.2	58	2.3	1/4	2.8	1/3	20	20	25	25
ECW2423RD00B*	208/240-1-60	10.2	58	2.3	1/4	2.8	1/3	20	20	25	25
ECW3022RD00B*	208/240-1-60	10.5	71	2.8	1/3	4.1	1/2	22	22	30	30
ECW3023RD00B*	208/240-1-60	10.5	71	2.8	1/3	4.1	1/2	22	22	30	30

* Includes Evap Fan Amps

Data is subject to change. Please verify most current information on www.firstco.com.



ECO SERIES AQUA-PAK

SPACE CONSTRAINED VERTICAL UNIT

GENERAL ASSEMBLY FOR STANDARD SLEEVE AND LOUVER

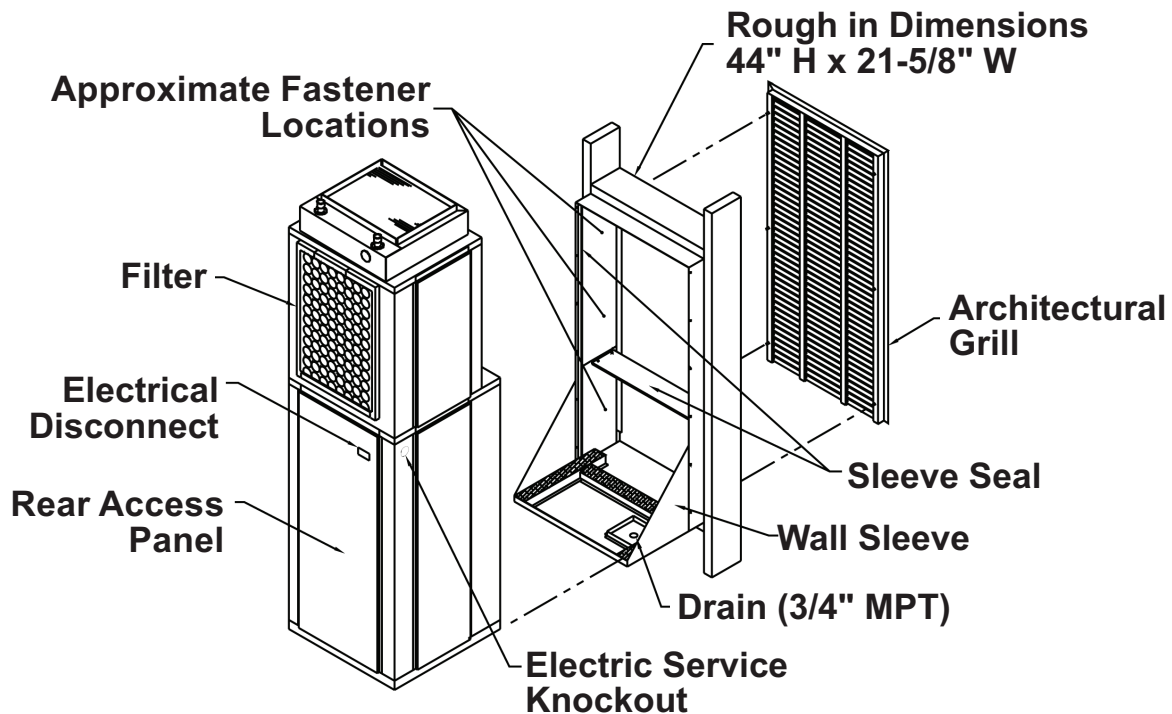

GENERAL ASSEMBLY FOR LARGE SLEEVE AND LOUVER SIZE 24B, 30

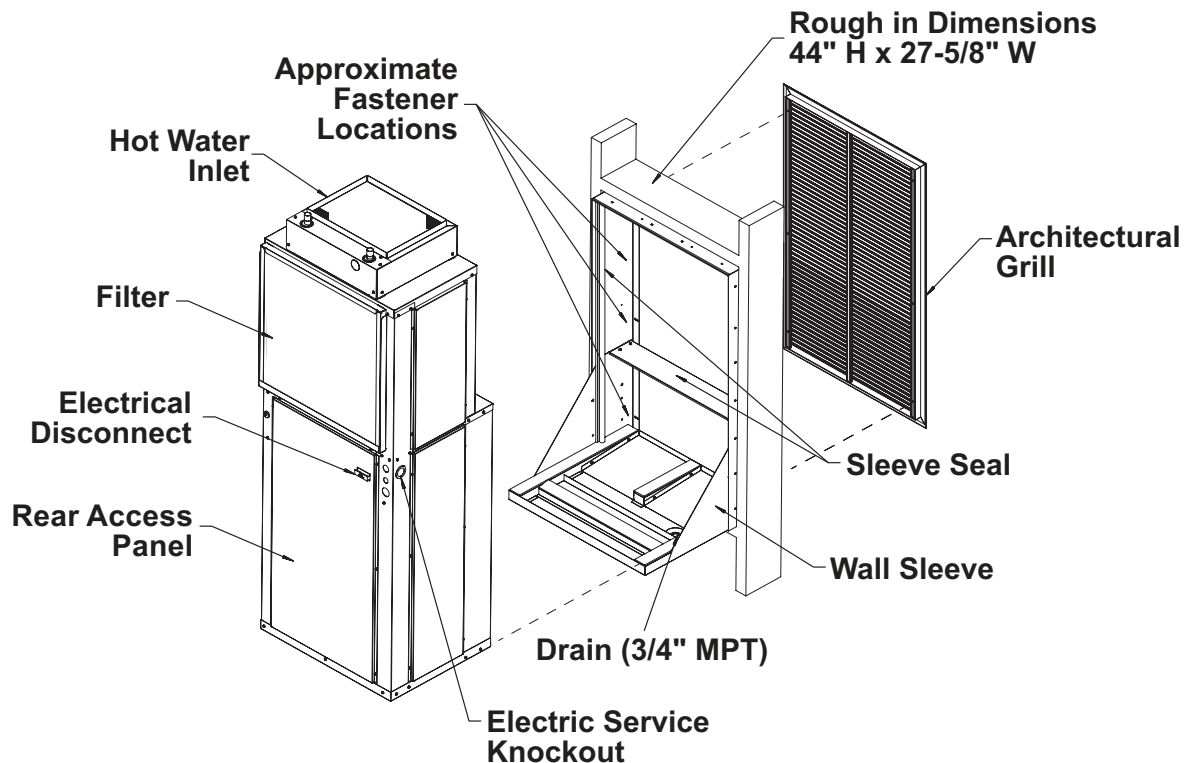

ECO SERIES AQUA-PAK

SPACE CONSTRAINED VERTICAL UNIT

GENERAL ASSEMBLY FOR LARGE SLEEVE AND LOUVER FOR 09-24A SIZES WITH BLOCK OFF

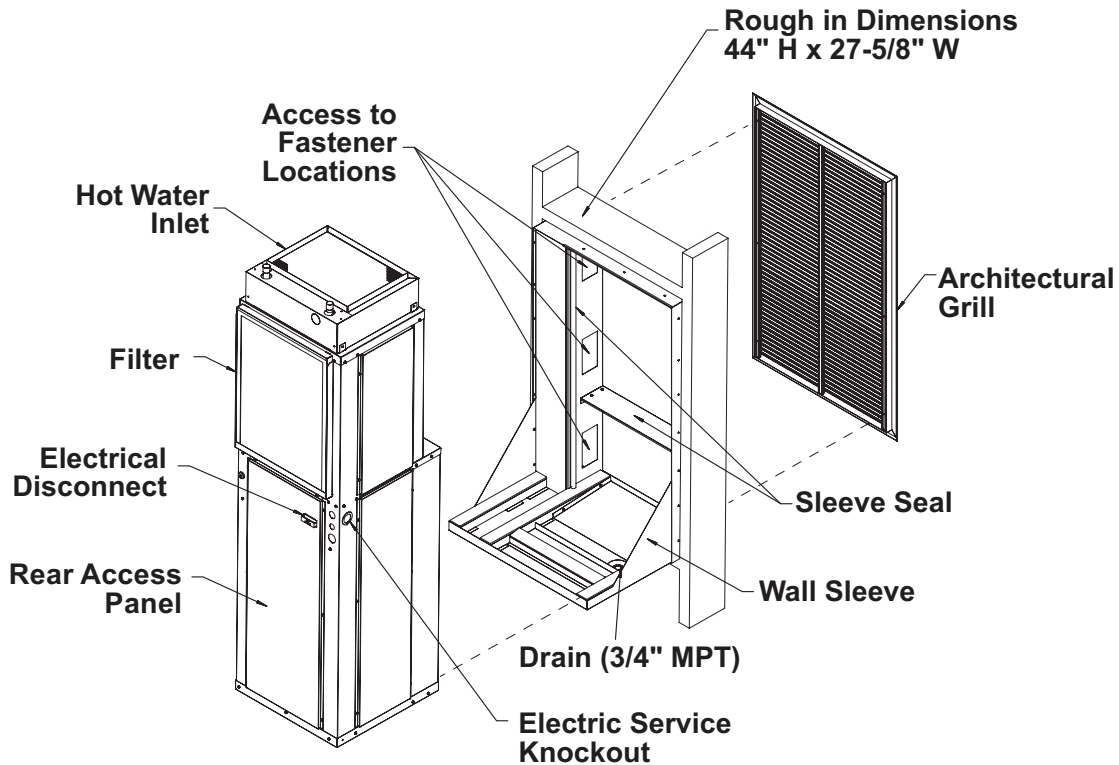

Note: Sleeve is set outside walls at 1/2" top and 1/4" bottom to insure proper slope.

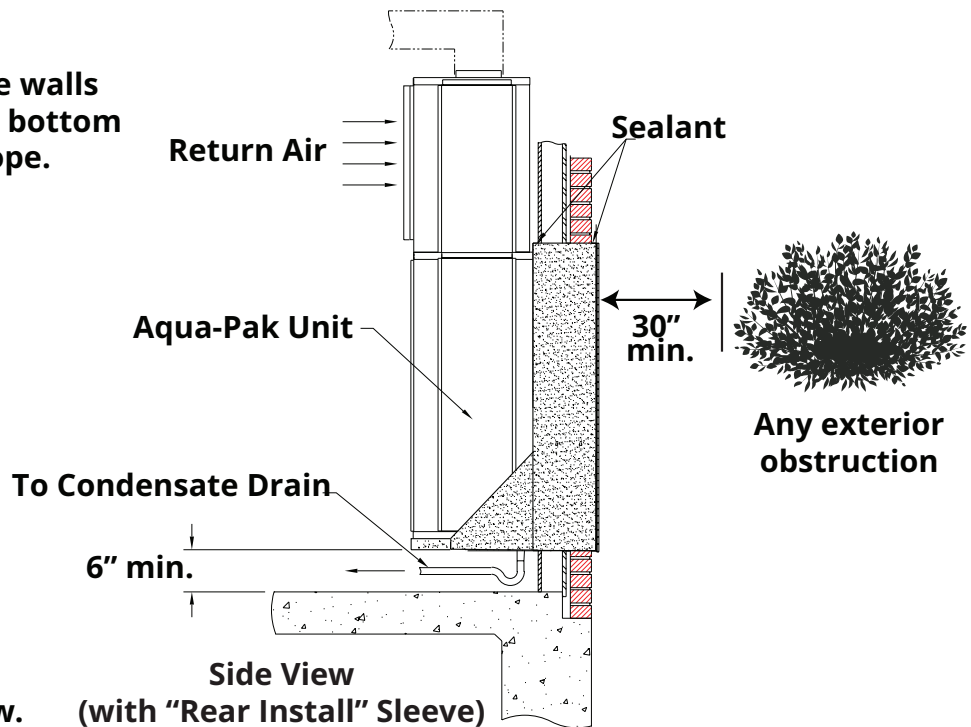

Note: Slope unit to outside for overflow.

ECO SERIES AQUA-PAK

SPACE CONSTRAINED VERTICAL UNIT

CLOSET DIMENSIONS

REAR INSTALLATION DETAIL FOR SMALL SLEEVE 21" WIDE (9-24A SIZE ONLY)

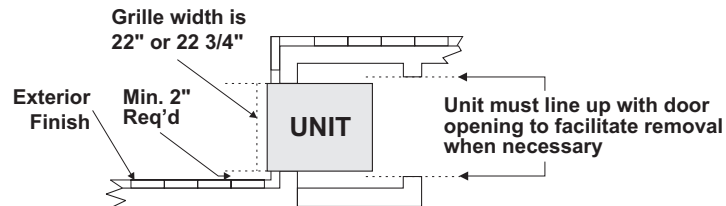

NOTES:

1. Sleeve rough-in opening is 44"(H) X 21-5/8"(W).
2. Bottom of opening should be approx. 6" above floor level.
3. Minimum 3" of clearance is required on all sides of the unit.

REAR INSTALLATION DETAIL FOR SMALL SLEEVE 21" WIDE (9-24A SIZE ONLY)

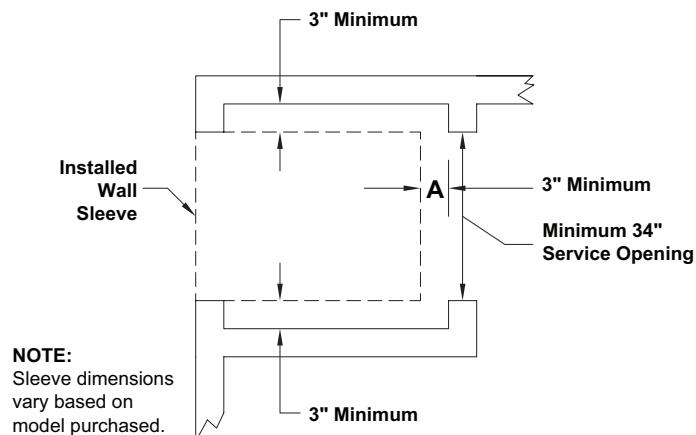

NOTE:

Provide minimum clearances as shown for interior closet dimensions.

REAR INSTALLATION DETAIL FOR LARGE SLEEVE 27" WIDE (24B, 30 SIZE OR 9-24A WITH BLOCKOFF)

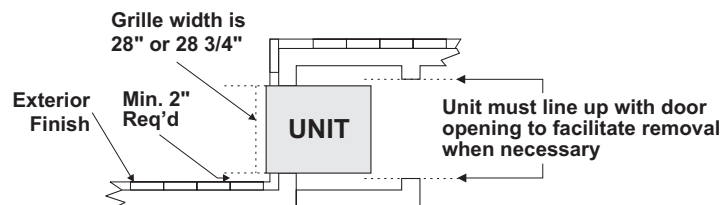

NOTES:

1. Sleeve rough-in opening is 44"(H) X 27-5/8"(W).
2. Bottom of opening should be approx. 6" above floor level.
3. Minimum 3" of clearance is required on all sides of the unit.



AMERICAN MADE. FAMILY OWNED.



FIRST CO.
P.O. BOX 270969 - DALLAS, TEXAS 75227
PH. (214) 388-5751 | FAX (214) 388-2255
WWW.FIRSTCO.COM

MARCH 2026