



# CLP-AQ

*Air Handler*



1.5 - 3 Ton Cooling or Heat Pump  
Up to 55,000 BTUH Hydronic Heating



# CLP-AQ

Today's higher efficiency air handlers are typically too large to fit into many smaller, space constrained closets. The **CLP-AQ** Series air handler is specifically designed to solve this problem. In addition, it's short height (less than 30"), makes it ideal for those applications where the closet space is minimal.

Return air (ducted or free) can come from the left side or the right side of the cabinet (determined by looking at the front of the cabinet) and must be identified at the time of order entry.

A high efficiency coil is factory installed on either side of the cabinet, and is available with a factory installed R-410A TXV. A 1" disposable filter is also factory installed within the cabinet and is easily accessible.

These fan coils are compatible with any source of hot water that does not exceed 180° and is NSF/ANSI certified for use with domestic water.

## STANDARD FEATURES

- Less than 30" tall
- Right or left hand return air (order must specify)
- Compatible with most major brands of condensing units and heat pumps (see (1) above)
- Hot water coil with circulating pump and hot water check valve
- High efficiency copper tube / aluminum fin coil with a factory installed R-410A TXV
- 120V motor, 24V controls
- Coil drain pan is coated with insulation to reduce corrosion
- Painted cabinet
- Factory installed hanger flange for wall mounting
- Easily accessible 1" disposable filter
- Shipped with wall mounting bracket

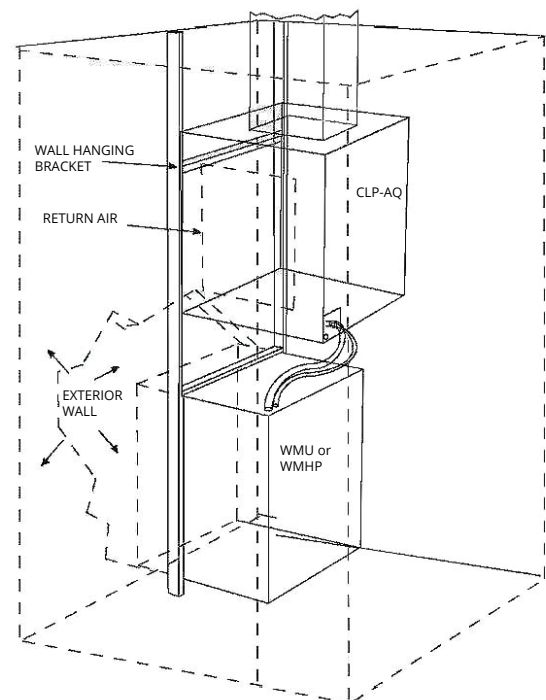

Typical installation over a Through the Wall  
Condensing Unit or Heat Pump

*First Co's customer is ultimately responsible for confirming which fan coil models are compatible with selected outdoor unit(s) and which expansion valves (if any) are required. To determine certified indoor/outdoor combinations, go to [www.firstco.com](http://www.firstco.com) or contact the factory.*

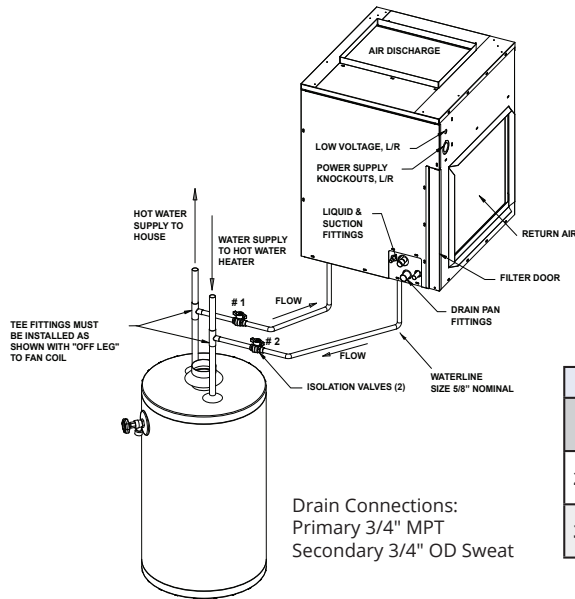

Drain Connections:  
Primary 3/4" MPT  
Secondary 3/4" OD Sweat

DIMENSIONS										
UNIT MODEL	H	W	D	A	B	C	E	F	G	SHIP WT.
24CLP-AQ	27-3/8	22-3/8	24-3/8	15-7/8	20-1/2	16	12	2-3/8	7-3/4	120 LBS.
36CLP-AQ	29-3/8	26-3/8	26-3/8	18-3/8	23-2/8	18	16	3	7-1/4	130 LBS.

COOLING COIL DATA (FACTORY INSTALLED)				
PRODUCT NUMBER	NOMINAL COOLING (TONS)	STANDARD METERING DEVICE	COIL CONNECTION (LIQ. & SUCT.)	FILTER
24CLP-AQ	2.0 / 1.5 tons	TXV	3/8 I.D. / 5/8 I.D.	18 X 24 X 1
36CLP-AQ	3.0 / 2.5 tons	TXV	(SWEAT)	20 X 25 X 1

ELECTRICAL DATA					
UNIT MODEL	MOTOR HP	AMPS		MIN. CIRCUIT AMPACITY	MAX. FUSE OR HACR BREAKER
		MOTOR	PUMP	120V	120V
24CLP-AQ	1/4	4.43	.57	7.0	15
36CLP-AQ	1/2	8.10	.57	11.0	15

BLOWER DATA										
UNIT MODEL	FAN SPEED	AMP	MOTOR HP	CFM vs EXTERNAL STATIC PRESSURE						
				.10	.15	.20	.25	.30	.40	.50
24CLP-AQ	HIGH	4.43	1/4	785	765	740	720	695	645	590
	LOW			445	440	430	402	410	385	350
36CLP-AQ	HIGH	8.1	1/2	1230	1195	1160	1125	1090	1010	930
	LOW			1080	1050	1025	995	965	895	825

HEATING PERFORMANCE					
UNIT MODEL	NOM. CFM	BTUH ENTERING WATER TEMP. Delta-T 20° F & GPM			
		130°	GPM	140°	GPM
24CLP-AQ	600	25,700	2.6	30,000	3.0
	700	28,300	2.8	33,000	3.3
	800	30,800	3.1	36,000	3.6
36CLP-AQ	1000	42,000	4.2	49,000	4.9
	1200	47,000	4.7	55,000	5.5

- Heat BTUH is at 70°F entering air temperature.
- Based on 20°F Delta-T. Velocity not to exceed 4ft./sec.

## MODEL NUMBERS:

MODEL SIZE (BTU)	MODEL (R-410A TXV)
24,000 / 18,000	24CLP-AQ (-RH or LH) R410 TXV
36,000 / 30,000	36CLP-AQ (-RH or LH) R410 TXV

All models are approved for cooling only.  
EXAMPLE: 36CLP-AQ-RH R410 TXV  
(3 Ton Right Hand Return with Installed R-410A TXV)



**WARNING AVERTISSEMENT ADVERTENCIA**  
Cancer and Reproductive Harm  
Cancer et Troubles de l'appareil reproducteur  
Cáncer y Daño Reproductivo  
[www.P65Warnings.ca.gov](http://www.P65Warnings.ca.gov) LBY0057

In keeping with its policy of continuous progress and product improvement, First Co. reserves the right to make changes without notice.



FIRST CO.  
P.O. BOX 270969 - DALLAS, TEXAS 75227  
PH. (214) 388-5751 | FAX (214) 388-2255  
WWW.FIRSTCO.COM

JULY 2024