

First Co.

CD SERIES

CDXW/X • CDXQ/X • CDXR/X • CDSW/X • CDSQ/X • CDSR/X
Ceiling Fan Coils

Compatible with R-32 and R-454B

Horizontal Recessed

HW Coils, Standard Pump, Hi Flow Pump

1.5 Thru 3 Tons Cooling

Up to 51,700 BTUH HW Heat

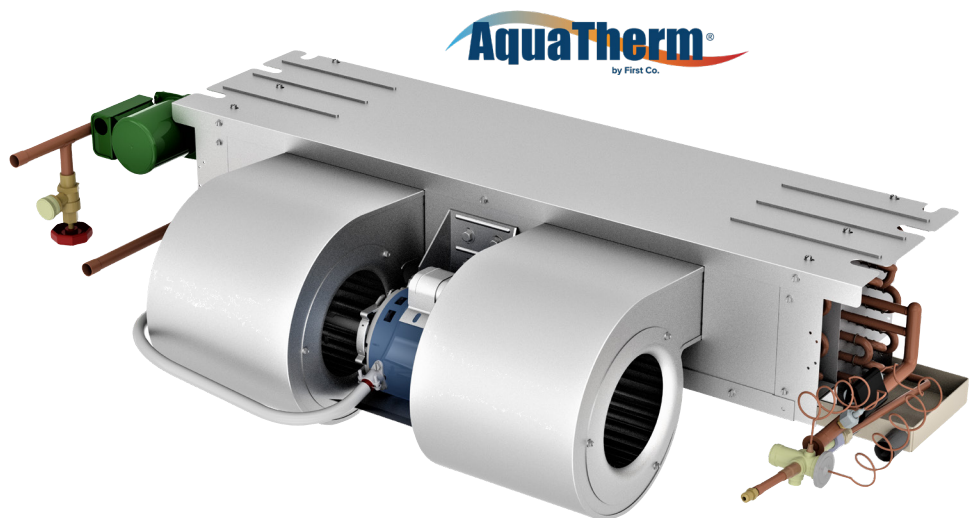

TABLE OF CONTENTS

NOMENCLATURE	3
SERIES FEATURES	4
ACCESS PANELS	6
DIMENSIONS	8
BLOWER DATA	10
CDXW HOT WATER COIL W/PSC MOTOR, NO PUMP	13
CDXWX HOT WATER COIL W/ECM MOTOR, NO PUMP	15
CDXQ HOT WATER HEATING W/STANDARD PUMP & PSC MOTOR.....	17
CDXQX HOT WATER HEATING W/STANDARD PUMP & ECM MOTOR	20
CDXR HI FLOW HEAT PUMP HOT WATER HEATING W/PSC MOTOR.....	22
CDXRX HI FLOW HEAT PUMP HOT WATER HEATING W/ECM MOTOR	24
CDSW HOT WATER COIL W/PSC MOTOR, NO PUMP	26
CDSWX HOT WATER COIL W/ECM MOTOR, NO PUMP	28
CDSQ HOT WATER HEATING W/STANDARD PUMP & PSC MOTOR.....	30
CDSQX HOT WATER HEATING W/STANDARD PUMP & ECM MOTOR	33
CDSR HI FLOW HEAT PUMP HOT WATER HEATING W/PSC MOTOR.....	35
CDSRX HI FLOW HEAT PUMP HOT WATER HEATING W/ECM MOTOR	37
SPECIFICATION GUIDE	39

First Co.'s customer is ultimately responsible for confirming which fan coil models are compatible with selected outdoor unit(s) and which expansion valves (if any) are required. To determine certified indoor/outdoor combinations, go to www.firstco.com or contact the factory.

In keeping with its policy of continuous progress and product improvement, First Co. reserves the right to make changes without notice.

NOMENCLATURE

FULL SERIES NOMENCLATURE

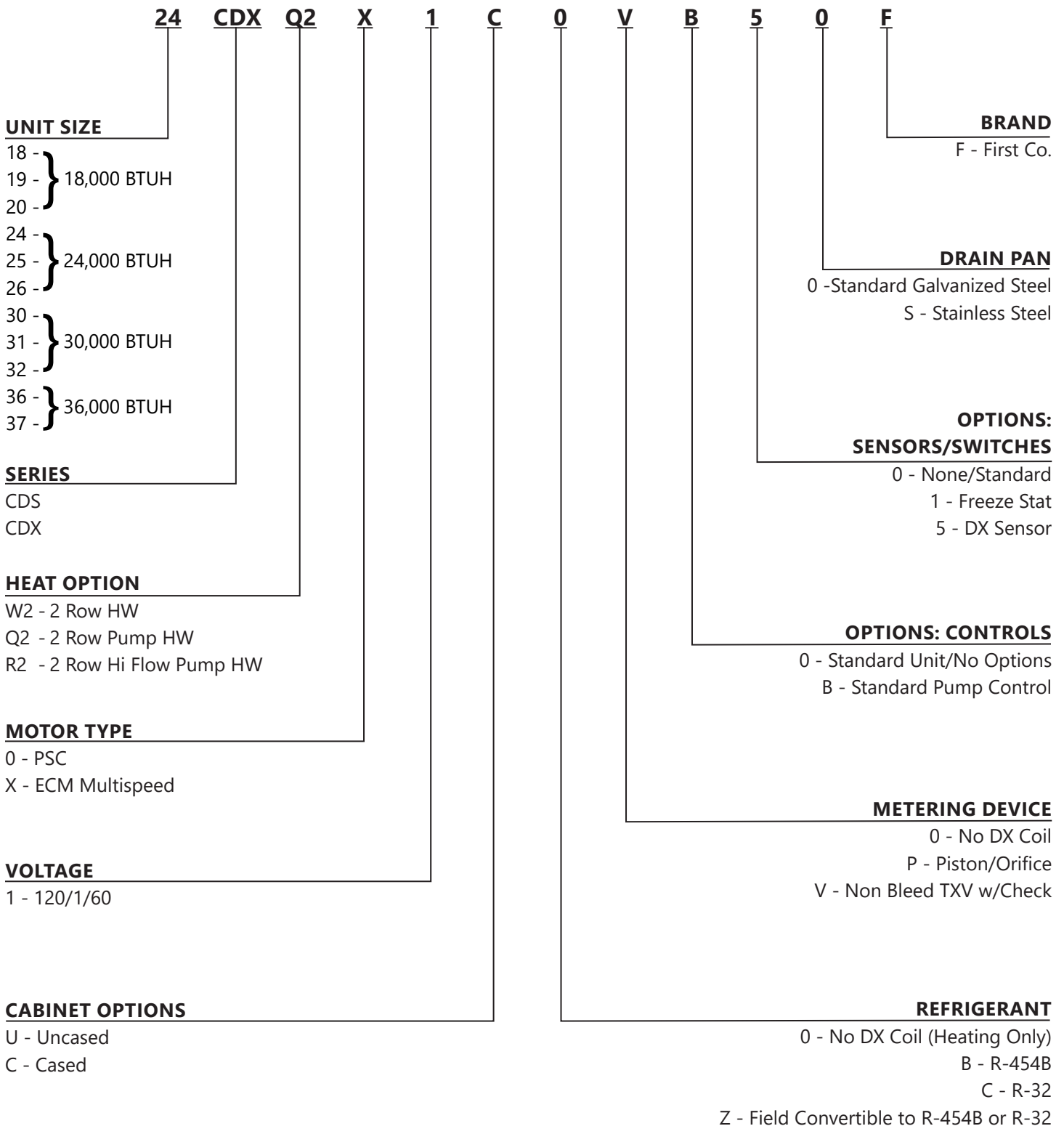

Model specific NOMENCLATURE presented at each respective section of document.

First Co.'s customer is ultimately responsible for confirming which fan coil models are compatible with selected outdoor unit(s) and which expansion valves (if any) are required. To determine certified indoor/outdoor combinations, go to www.AHRInet.org.

CD SERIES

CEILING FAN COILS

The space-saving CD Series fan coil is only 10" high (11" with enclosure) thus allowing it to recess in a ceiling. Recessed ceiling fan coils save valuable floor space and eliminate costly "equipment" closets.

All CD Series fan coils include a 120/24V transformer and are completely prewired. A sloped drain pan allows positive drainage of condensate.

These fan coils are compatible with any source of hot water that does not exceed 180°F, and is NSF/ANSI certified for use with domestic water.

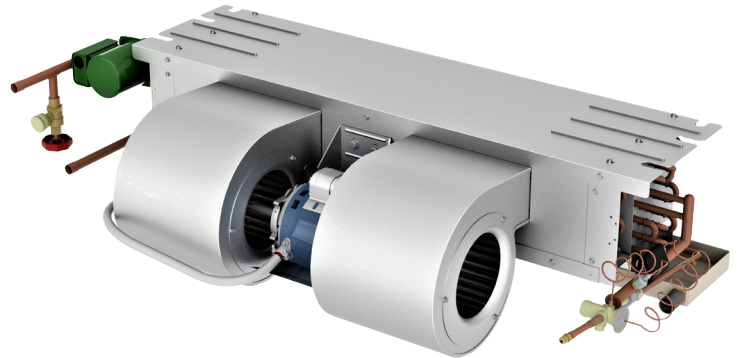

STANDARD FEATURES

- Factory installed service switch.
- Freeze protector on HW coil.
- Freeze protector on DX coil.
- Two-speed fan operation.
- Drain pan has 3/4" NPT primary and secondary (overflow) fittings.
- 120V motor, 24V controls.
- Highly efficient copper tube/aluminum fin heating and cooling coils. Cooling coils are compatible with R-454B, R-32 using non-bleed TXVs or piston type metering devices.
- Units ordered for R-454B (Option B) and R-32 (Option C) are factory configured with TXV or piston and factory installed refrigerant sensor.
- Field convertible units (Option Z) are configured for R-454B and R-32 refrigerants with a factory installed refrigerant sensor. TXV kits are available.
- Insulated and coated galvanized steel drain pan is sloped for proper drainage.
- Effective January 2016, cabinet air leakage is no more than 2% when tested in accordance with ASHRAE 193.

OPTIONAL ACCESSORIES

- Attractive off-white return air / access panel with captive screws (panels can be field painted).
- IAQ filter panels.
- Fully insulated enclosure with matching ceiling panel allows for ducted return air. Enclosure can be pre-installed.
- Condensate overflow switch (field installed) (# SS3).

CD SERIES

CEILING FAN COILS

OPTIONAL ACCESSORIES (CONT'D)

IMPORTANT NOTE

All Z model units ship with factory-installed refrigerant sensor. Field installed TXV must be compatible with A2L refrigerant being used. Failure to maintain use of refrigerant sensor may result in unit damage, property damage, and/or death. Warranty will be void.

EXPANSION VALVE KITS (HEAT PUMP OR COOLING ONLY)

PART NUMBER	DESCRIPTION
9EVR454B-1A	For all CD Series R-454B TXV (For Z options only)
9EVR32-1A	For all CD Series R-32 TXV (For Z options only)

NOTES:

1. Above expansion valve kits are approved for both cooling only (non heat pump) or heat pumps applications.
2. Valves are non-bleed type. Field added. Hard start kit may be required.
3. Valves have screw-on connections.

CONTROL FEATURES

WHEN "B" IS SELECTED FOR STANDARD PUMP CONTROL

MULTI-FUNCTION MICRO-PROCESSOR CIRCUIT BOARD WITH:

- Automatic pump timer (heating mode) - Circulating pump energizes to purge the HW coil.
 - 5 minutes twice daily, or
 - 60 seconds four times daily.
- Blower-on fan delay (heating mode) - The HW coil is preheated for 90 seconds before the blower starts.
- Blower-off fan delay (heating mode) - Blower runs for 20 seconds after the thermostat is satisfied to extract residual heat.
- Blower-off delay (cooling mode) - Blower runs for 45 seconds after the thermostat is satisfied to improve cooling efficiency.

CD SERIES

CEILING FAN COILS

CEILING ACCESS PANELS

CEILING ACCESS PANELS							
FOR MODEL	PANEL NO. (STD.)	PANEL NO. (IAQ)	DESCRIPTION	CEILING PANEL OPENING		PANEL FRAME DIMS (OUTSIDE)	
18/19CD*S/X	966	966-M8	LOUVERED	24-1/2	46	27-1/2	49
	966-1	NA	NON-LOUVERED	24-1/2	46	27-1/2	49
20/24/25CD*S/X	967	967-M8	LOUVERED	24-1/2	52-1/2	27-1/2	55-1/2
	967-1	NA	NON-LOUVERED	24-1/2	52-1/2	27-1/2	55-1/2
26/30/31CD*S/X	967-6	967-6-M8	LOUVERED	24-1/2	60	27-1/2	63
	967-7	NA	NON-LOUVERED	24-1/2	60	27-1/2	63
32/36/37CD*S/X	967-8	967-8-MA	LOUVERED	24-1/2	67	27-1/2	70
	967-5	NA	NON-LOUVERED	24-1/2	67	27-1/2	70



SOLID
965-1, 966-1, 967-1, 967-7

LOUVERED
965, 966, 967, 967-6
(Louvers may differ from picture).
Louvered panels accept 20x20x1" filter
(field supplied).

966-M8, 967-M8
(accepts 2-20x20x1 filter)
967-6-M8
(accepts 2-20x25x1 filter)
967-8-M8
(accepts 2-20x30x1 filter)
GlasFloss® Industries Series HV filter or
equivalent is recommended.

CD SERIES

CEILING FAN COILS

ENCLOSURE DATA

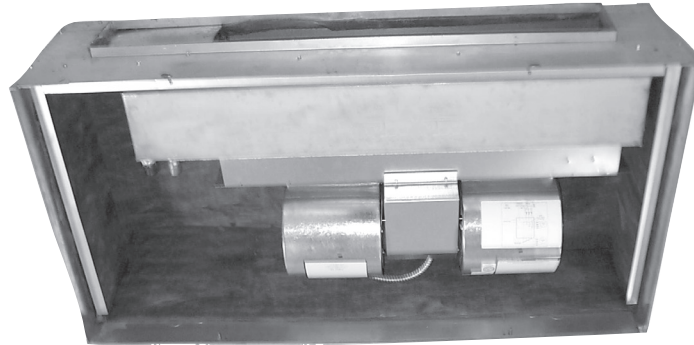

Picture shown is a CD*S/X - C model (available from the factory as a complete unit).

ENCLOSURE INSTALLATION SUPPORT FRAMING

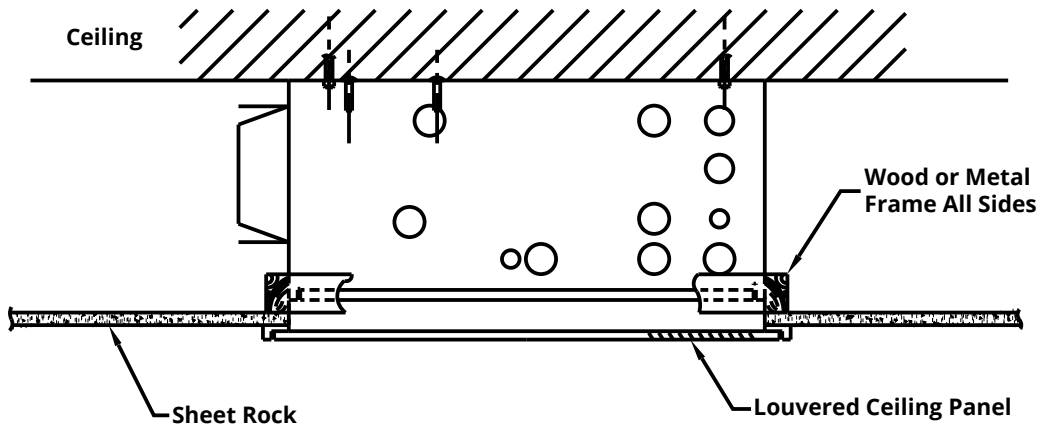

ENCLOSURE CONNECTION LOCATIONS

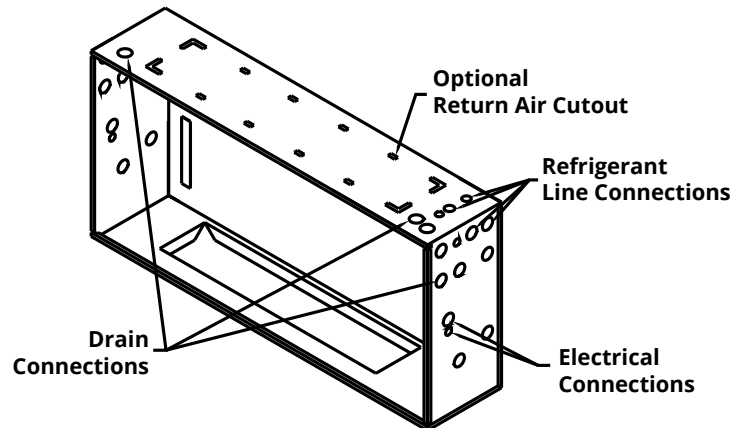

CD SERIES

CEILING FAN COILS

DIMENSIONS – UNCASD VERSION

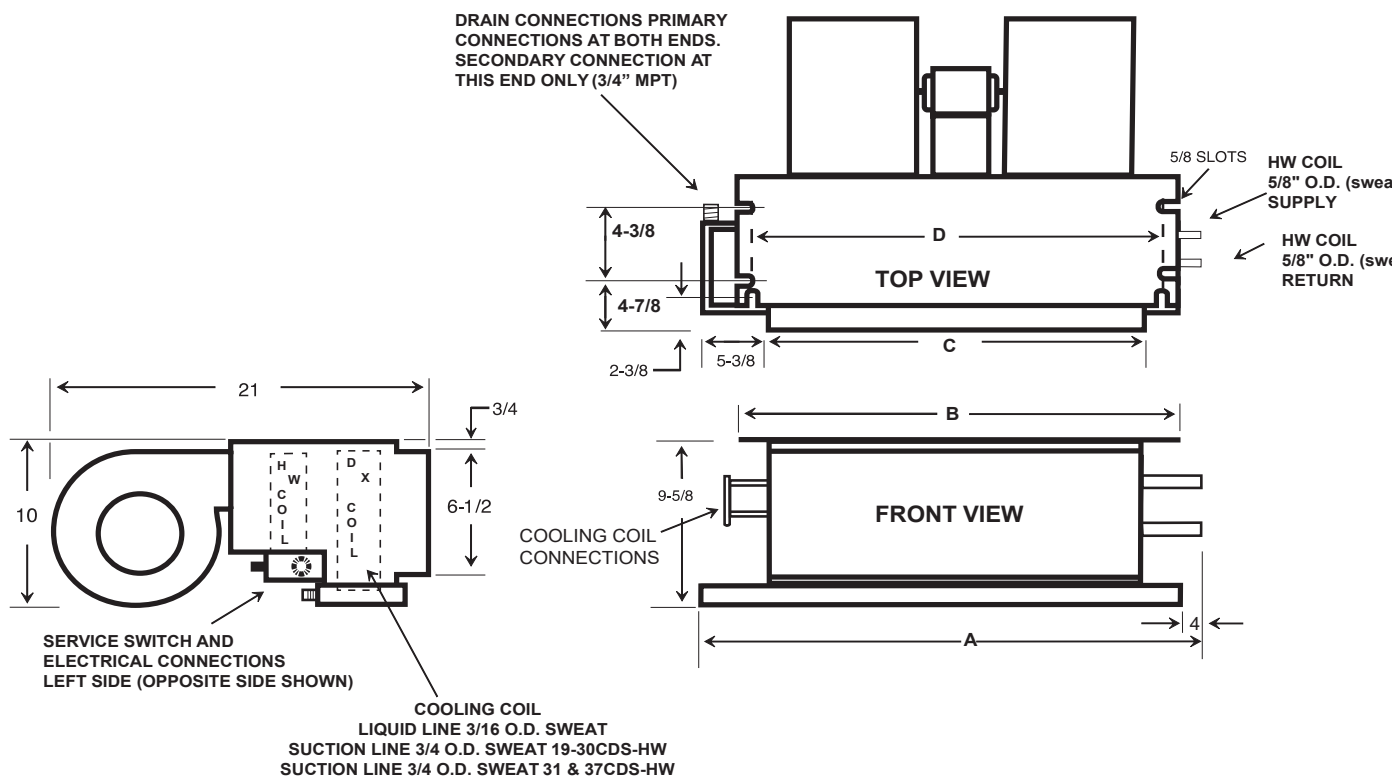
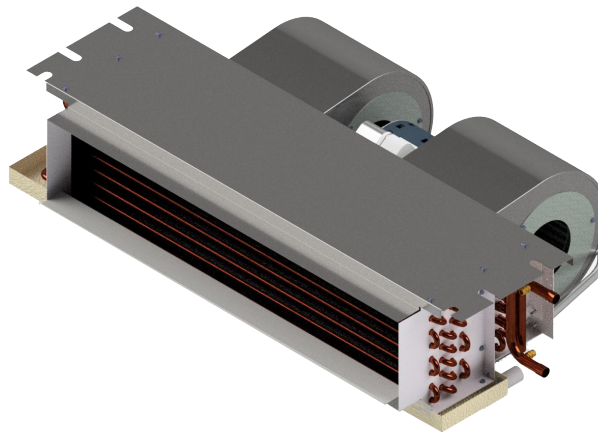

ALL CD SERIES – PHYSICAL DIMENSIONS

UNIT MODEL	A	B	C	D
18/19CD*S/X	38-1/8	37-1/4	30-1/8	34-3/4
20/24/25CD*S/X	44-1/8	43-1/4	36-1/8	40-3/4
26/30/31CD*S/X	50-1/8	49-1/4	42-1/8	46-3/4
32/36/37CD*S/X	57-1/8	56-1/4	49-1/8	53-3/4

CD SERIES

CEILING FAN COILS

DIMENSIONS – CASED VERSION

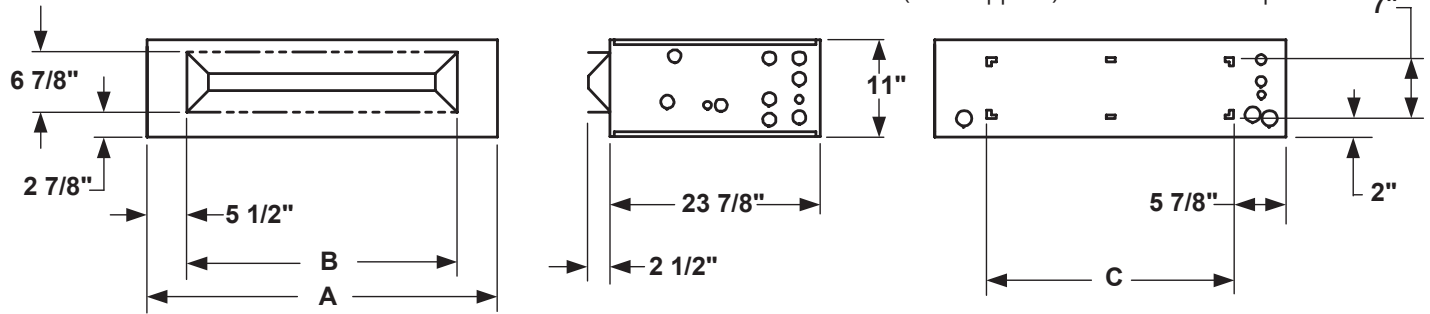

ALL CD SERIES – ENCLOSURE DIMENSIONS					PANEL NO. (STD.)	PANEL NO. (IAQ)	DESCRIPTION	CEILING PANEL OPENING		PANEL FRAME DIMS (OUTSIDE)	
MODEL	ENCLOSURE	A	B	C	-	-	(2)	W	L	W	L
18/19CD*S/X	9ECDX01 (1)	45-3/4	30-7/8	34	966	966-M8	LOUVERED	24-1/2	46	27-1/2	49
					966-1	NA	NON LOUVERED	24-1/2	46	27-1/2	49
20/24/25CD*SX	9ECDX02 (1)	51-3/4	36-7/8	40	967	967-M8	LOUVERED	24-1/2	52-1/2	27-1/2	55-1/2
					967-1	NA	NON LOUVERED	24-1/2	52-1/2	27-1/2	55-1/2
26/30/31CD*S/X	9ECDX03 (1)	58-1/2	42-7/8	46-3/4	967-6	967-6-M8	LOUVERED	24-1/2	60	27-1/2	63
					967-7	NA	NON LOUVERED	24-1/2	60	27-1/2	63
32/36/37CD*S/X	9ECDX04 (1)	66-1/2	49-7/8	54-3/4	967-8	967-8-M8	LOUVERED	24-1/2	67	27-1/2	70
					967-5	NA	NON LOUVERED	24-1/2	67	27-1/2	70

CDX SERIES – WITH PSC MOTOR

BLOWER DATA - ALL CDX SERIES MODELS WITH PSC MOTOR													
UNIT MODEL	MOTOR (1)		MOTOR HP (120V)	MIN. CKT. AMPACITY (120V)	MAX. CKT. PROTECTION	CFM vs. EXTERNAL STATIC PRESSURE (3)							
	RPM	AMPS				0.05	0.10	0.15	0.20	0.25	0.30	0.35	0.40
18/19/20CDX	1550	2.3	1/5	3	15	710	680	650	620	590	560	530	500
24/25/26CDX	1550	3.6	1/4	5	15	880	840	800	760	720	680	640	600
30/31CDX	1550	4.6	1/5	6	15	1100	1060	1020	980	930	880	830	780
32CDX	1550	4.6	1/5	6	15	1160	1130	1095	1060	1025	990	950	910
36/37CDX	1550	4.6	1/5	6	15	1310	1260	1210	1160	1110	1060	1000	940

NOTES:

1. Units should not be applied to a system with less than 350 CFM/Ton airflow.
2. Motors are 120V and operate on high speed for cool and low speed for heating.
3. CFM vs. static at high motor speed.
4. Add .05 static when enclosure and/or ceiling panel is used.
5. 31, 32 and 37 CDXW have two motors and four blowers.

CDS SERIES – WITH PSC MOTOR

BLOWER DATA - ALL CDS SERIES MODELS WITH PSC MOTOR													
UNIT MODEL	MOTOR (1)		MOTOR HP (120V)	MIN. CKT. AMPACITY (120V)	MAX. CKT. PROTECTION	CFM vs. EXTERNAL STATIC PRESSURE (3)							
	RPM	AMPS				0.05	0.10	0.15	0.20	0.25	0.30	0.35	0.40
18/19/20CDS	1550	2.3	1/5	3	15	745	705	670	645	610	580	550	520
24/25/26CDS	1550	3.6	1/4	5	15	925	875	840	785	740	715	670	630
30/31CDS	1550	4.6	1/5	6	15	1135	1115	1050	1030	975	905	870	820
32CDS	1550	4.6	1/5	6	15	1195	1185	1140	1115	1065	1020	990	935
36/37CDS	1550	4.6	1/5	6	15	1360	1325	1260	1205	1155	1100	1030	980

NOTES:

1. Units should not be applied to a system with less than 350 CFM/Ton airflow.
2. Motors are 120V and operate on high speed for cool and low speed for heating.
3. CFM vs. static at high motor speed.
4. Add .05 static when enclosure and/or ceiling panel is used.
5. 31, 32 and 37 CDSW have two motors and four blowers.

CDX SERIES – WITH ECM MOTOR

BLOWER DATA - ALL CDX SERIESX MODELS WITH ECM MOTOR												
MODEL	MOTOR HP	SPEED TAP	TAP COLOR	BHP	MOTOR AMPS	CFM vs. EXTERNAL STATIC PRESSURE						
						0.10	0.15	0.20	0.25	0.30	0.35	0.40
18/19/20CDX*X	1/2	OPTIONAL HIGH	GREEN	0.22	2.8	760	745	730	715	700	685	670
		STD. HIGH	ORANGE	0.17	2.1	670	650	630	615	600	588	570
		STD. LOW	YELLOW	0.14	1.6	570	555	540	520	500	480	---
24/25/26CDX*X	1/2	OPTIONAL HIGH	WHITE	0.30	3.8	980	960	940	920	900	875	850
		STD. HIGH	GREEN	0.25	3.0	890	870	850	830	810	790	770
		STD. LOW	ORANGE	0.21	2.5	800	775	750	725	700	675	---
		OPTIONAL LOW	YELLOW	0.18	2.0	730	710	690	670	650	630	---
30/31CDX*X	1/2	OPTIONAL HIGH	WHITE	0.40	4.7	1160	1145	1130	1115	1100	1080	1060
		STD. HIGH	GREEN	0.33	3.8	1060	1040	1020	1105	990	975	960
		STD. LOW	ORANGE	0.28	3.2	970	955	940	920	900	880	860
		OPTIONAL LOW	YELLOW	0.23	2.6	870	850	830	810	790	770	---
32CDX*X	1/2	OPTIONAL HIGH	WHITE	0.39	4.8	1220	1200	1180	1155	1125	1095	1065
		STD. HIGH	GREEN	0.27	3.2	1030	1005	985	960	940	920	900
		STD. LOW	ORANGE	0.22	2.5	905	885	860	840	820	800	---
		OPTIONAL LOW	YELLOW	0.16	1.8	725	705	685	670	650	630	---
36/37CDX*X	1/2 (2)	OPTIONAL HIGH	WHITE	0.45	5.6	1380	1360	1340	1320	1300	1280	1260
		STD. HIGH	GREEN	0.38	4.7	1290	1270	1250	1225	1200	1175	1150
		STD. LOW	ORANGE	0.31	3.7	1130	1105	1080	1055	1030	1010	---
		OPTIONAL LOW	YELLOW	0.26	3.0	1000	975	950	920	890	875	---

NOTES:

1. Units should not be applied to a system with less than 350 CFM/Ton airflow.
2. Shaded speeds are factory settings.
3. Add .05 static when enclosure and/or ceiling panel is used.
4. 37 CDXX has two motors and four blowers.

CDS SERIES – WITH ECM MOTOR

BLOWER DATA - ALL CDS MODELS WITH ECM MOTOR												
MODEL	MOTOR HP	SPEED TAP	TAP COLOR	BHP	MOTOR AMPS	CFM vs. EXTERNAL STATIC PRESSURE						
						0.10	0.15	0.20	0.25	0.30	0.35	0.40
18/19/20CDS*X	1/2	OPTIONAL HIGH	GREEN	0.22	2.8	785	765	750	745	735	720	695
		STD. HIGH	ORANGE	0.17	2.1	705	685	655	645	620	610	585
		STD. LOW	YELLOW	0.14	1.6	595	575	565	545	525	495	---
24/25/26CDS*X	1/2	OPTIONAL HIGH	WHITE	0.30	3.8	1030	1000	980	965	925	910	885
		STD. HIGH	GREEN	0.25	3.0	925	905	875	870	840	820	810
		STD. LOW	ORANGE	0.21	2.5	825	815	780	760	730	695	---
		OPTIONAL LOW	YELLOW	0.18	2.0	765	745	710	705	685	660	---
30/31CDS*X	1/2	OPTIONAL HIGH	WHITE	0.40	4.7	1195	1180	1175	1160	1145	1125	1115
		STD. HIGH	GREEN	0.33	3.8	1090	1070	1060	1160	1030	1015	1010
		STD. LOW	ORANGE	0.28	3.2	1020	985	985	950	935	915	885
		OPTIONAL LOW	YELLOW	0.23	2.6	905	875	865	840	815	795	---
32CDS*X	1/2	OPTIONAL HIGH	WHITE	0.39	4.8	1270	1250	1215	1215	1170	1140	1120
		STD. HIGH	GREEN	0.27	3.2	1060	1055	1035	990	985	950	935
		STD. LOW	ORANGE	0.22	2.5	930	930	885	880	855	830	---
		OPTIONAL LOW	YELLOW	0.16	1.8	745	725	705	695	670	660	---
36/37CDS*X	1/2 (2)	OPTIONAL HIGH	WHITE	0.45	5.6	1435	1415	1405	1360	1365	1320	1325
		STD. HIGH	GREEN	0.38	4.7	1355	1320	1315	1275	1260	1235	1185
		STD. LOW	ORANGE	0.31	3.7	1185	1160	1125	1110	1070	1040	---
		OPTIONAL LOW	YELLOW	0.26	3.0	1040	1005	1000	965	935	920	---

NOTES:

1. Units should not be applied to a system with less than 350 CFM/Ton airflow.
2. Shaded speeds are factory settings.
3. Add .05 static when enclosure and/or ceiling panel is used.
4. 37 CDSX has two motors and four blowers.

CD SERIES

HOT WATER COIL W/PSC MOTOR, NO PUMP

CDXW

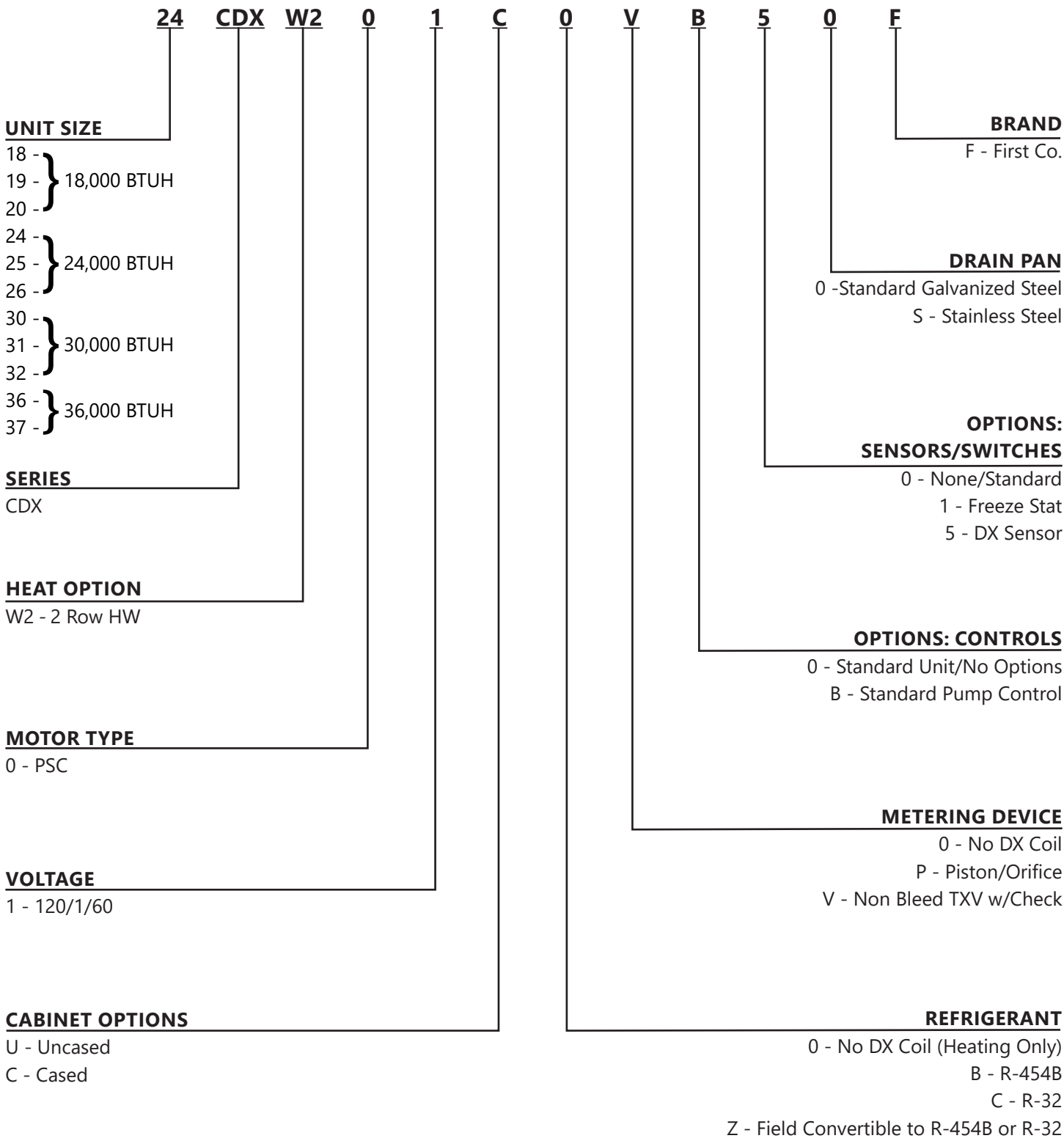

CD SERIES

HOT WATER COIL W/PSC MOTOR, NO PUMP

CDXW

DATA TABLE

CDX SERIES – WITH HOT WATER COILS

PSC MOTOR WITH HOT WATER COILS, NO PUMP

PERFORMANCE DATA CDXW								
UNIT MODEL	NOMINAL COOLING BTUH	PRESS. DROP (FT. WTR)	BTUH (1000) AT ENTERING WATER TEMPERATURE Delta -T 20°F & GPM					
			120°F	GPM	140°F	GPM	180°F	GPM
18/19CDXW	18,000	0.7	10.3	1.0	14.4	1.4	22.6	2.3
		2.0	12.0	1.2	16.8	1.7	26.4	2.6
		3.3	12.9	1.3	18.0	1.8	28.3	2.8
20CDXW	18,000	0.8	10.9	1.1	15.3	1.5	24.0	2.4
		2.1	12.9	1.3	18.0	1.8	28.3	2.8
		4.1	13.7	1.4	19.2	1.9	30.2	3.0
24/25CDXW	24,000	2.1	14.7	1.5	20.6	2.1	32.4	3.2
		4.1	15.9	1.6	22.2	2.2	34.9	3.5
		6.6	16.5	1.7	23.1	2.3	36.3	3.6
26CDXW	24,000	2.2	15.7	1.6	22.0	2.2	34.6	3.5
		4.3	17.0	1.7	23.8	2.4	37.4	3.7
		6.8	17.6	1.8	24.7	2.5	38.8	3.9
30/31CDXW	30,000	2.2	17.3	1.7	24.2	2.4	38.0	3.8
		4.3	18.8	1.9	26.3	2.6	41.3	4.1
		6.8	19.6	2.0	27.5	2.8	43.2	4.3
32CDXW	30,000	2.8	18.4	1.8	25.8	2.6	40.5	4.1
		5.4	20.1	2.0	28.2	2.8	44.3	4.4
		8.5	21.1	2.1	29.5	3.0	46.4	4.6
36/37CDXW	36,000	2.8	19.7	2.0	27.6	2.8	43.4	4.3
		5.4	21.7	2.2	30.4	3.0	47.8	4.8
		8.5	22.8	2.3	31.9	3.2	50.1	5.0

NOTES:

1. Heat BTUH is at 70° F EAT.
2. Based on 20°F Delta - T. Velocity not to exceed 4ft./sec.
3. 120 degree and 180 degree data is supplied for boiler applications.
4. Heating BTUH output will not exceed output of water heater.
5. Approved for installation with 0" clearance to combustible material.
6. Use capacities when First Co. "Flow Control Module" is used (# 940-3CV).
7. Freeze protection standard on hot water and DX coils.

ELECTRICAL DATA CDXWR					
UNIT MODEL	MOTOR (1)		MOTOR HP (120V)	MIN. CKT. AMPACITY (120V)	MAX. CKT. PROTECTION
	RPM	AMPS			
18/19/20CDXW	1550	2.3	1/5	3	15
24/25/26CDXW	1550	3.6	1/4	5	15
30/31CDXW	1550	4.6	1/5	6	15
32CDXW	1550	4.6	1/5	6	15
36/37CDXW	1550	4.6	1/5	6	15

CD SERIES

HOT WATER COIL W/ECM MOTOR, NO PUMP

CDXWX

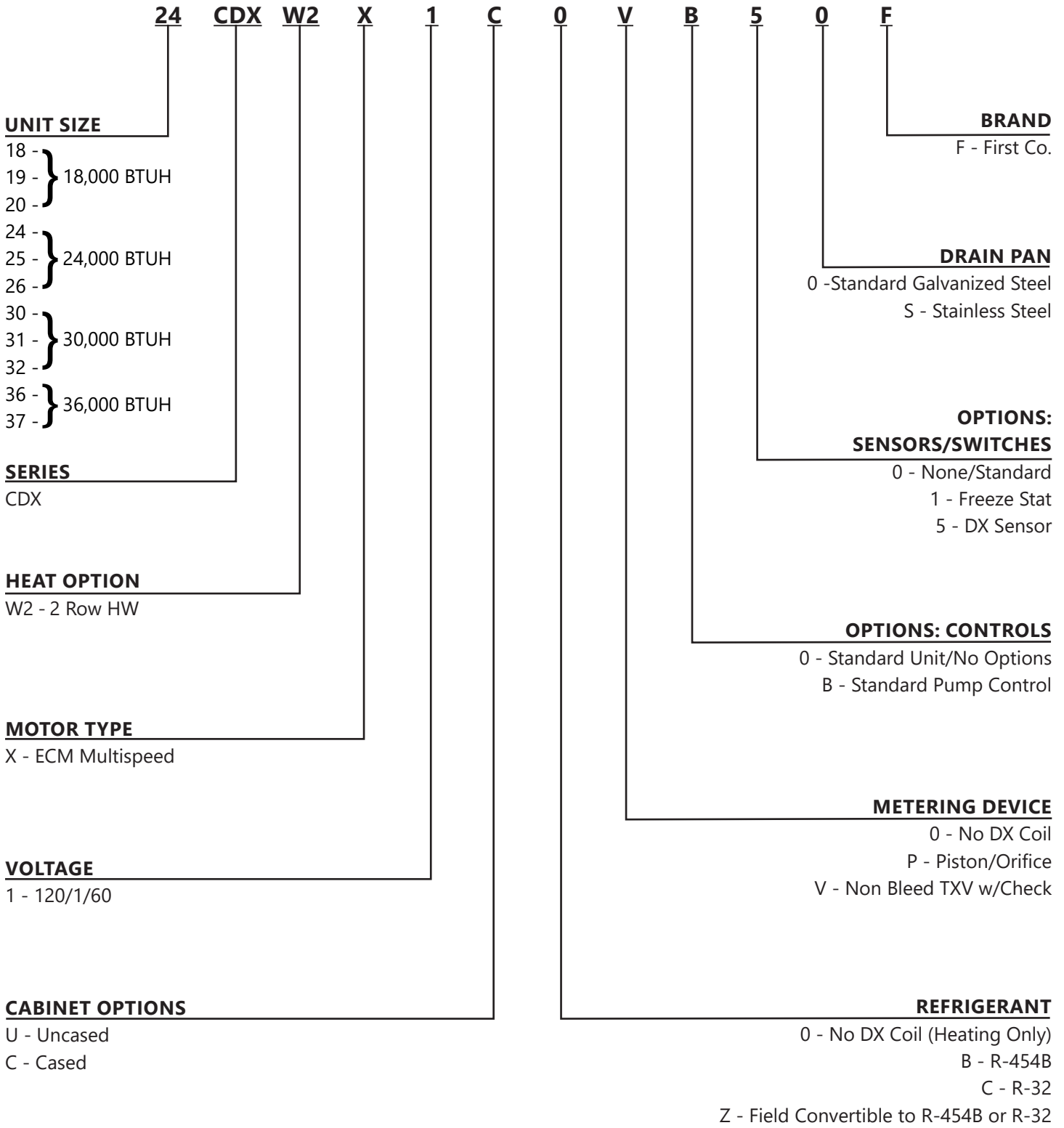

CD SERIES

HOT WATER COIL W/ECM MOTOR, NO PUMP

CDXWX

DATA TABLES

CDX SERIES - WITH HOT WATER COILS

ECM MOTOR WITH HOT WATER COILS, NO PUMP

PERFORMANCE DATA CDXWX								
UNIT MODEL	NOMINAL COOLING BTUH	PRESS. DROP (FT. WTR)	BTUH (1000) AT ENTERING WATER TEMPERATURE Delta-T-20°F & GPM					
			120°F	GPM	140°F	GPM	180°F	GPM
18/19CDXWX	18,000	0.7	10.3	1.0	14.4	1.4	22.6	2.3
		2.0	12.0	1.2	16.8	1.7	26.4	2.6
		3.3	12.9	1.3	18.0	1.8	28.3	2.8
20CDXWX	18,000	0.8	10.9	1.1	15.3	1.5	24.0	2.4
		2.1	12.9	1.3	18.0	1.8	28.3	2.8
		4.1	13.7	1.4	19.2	1.9	30.2	3.0
24/25CDXWX	24,000	2.1	14.7	1.5	20.6	2.1	32.4	3.2
		4.1	15.9	1.6	22.2	2.2	34.9	3.5
		6.6	16.5	1.7	23.1	2.3	36.3	3.6
26CDXWX	24,000	2.2	15.7	1.7	22.0	2.4	34.6	3.8
		4.3	17.0	1.9	23.8	2.6	37.4	4.1
		6.8	17.6	2.0	24.7	2.8	38.8	4.3
30/31CDXWX	30,000	2.2	17.3	1.7	24.2	2.4	38.0	3.8
		4.3	18.8	1.9	26.3	2.6	41.3	4.1
		6.8	19.6	2.0	27.5	2.8	43.2	4.3
32CDXWX	30,000	2.8	18.4	1.8	25.8	2.6	40.5	4.1
		5.4	20.1	2.0	28.2	2.8	44.3	4.4
		8.5	21.1	2.1	29.5	3.0	46.4	4.6
36/37CDXWX	36,000	2.8	19.7	2.0	27.6	2.8	43.4	4.3
		5.4	21.7	2.2	30.4	3.0	47.8	4.8
		8.5	22.8	2.3	31.9	3.2	50.1	5.0

NOTES:

1. Heat BTUH is at 70° F EAT.
2. Based on 20°F Delta - T. Velocity not to exceed 4ft./sec.
3. 120 degree and 180 degree data is supplied for boiler applications.
4. Heating BTUH output will not exceed output of water heater.
5. Approved for installation with 0" clearance to combustible material.
6. Use capacities when First Co. "Flow Control Module" is used (# 940-3CV).
7. Freeze protection standard on hot water and DX coils.

ELECTRICAL DATA CDXWX				
UNIT MODEL	MOTOR HP	AMPS	MIN. CIR AMPACITY	MAX CIR PROTECTION
		MOTOR		
18/19/20CDXWX	1/2	7.0	9	15
24/25/26CDXWX	1/2	7.0	9	15
30/31CDXWX	1/2	7.0	9	15
32CDXWX	1/2	7.0	9	15
36/37CDXWX	1/2 (2)	7.0	16	20

CD SERIES

HOT WATER HEATING W/STANDARD PUMP & PSC MOTOR

CDXQ

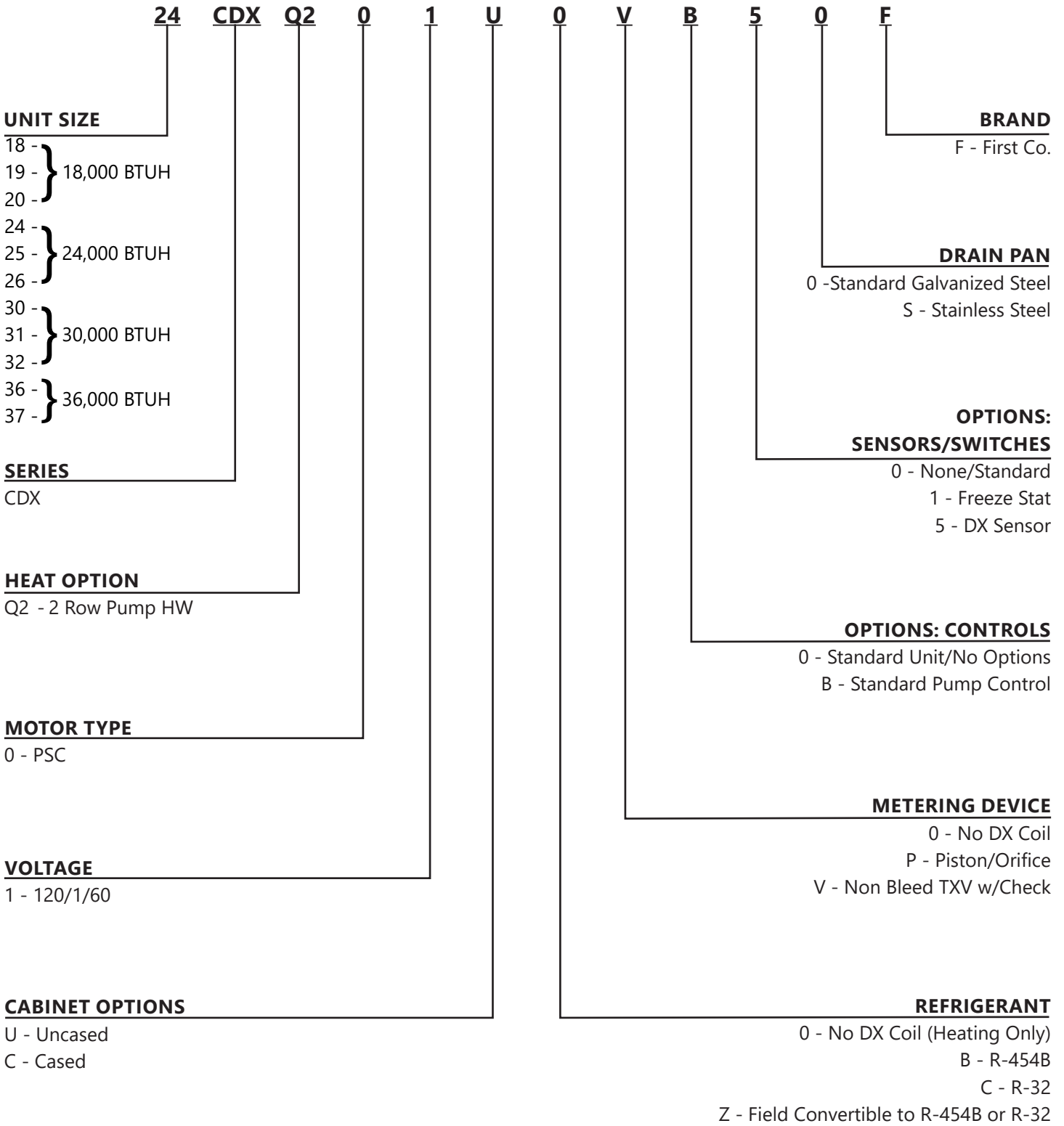

PHYSICAL DIMENSIONS UNCASED VERSION WITH STANDARD PUMP

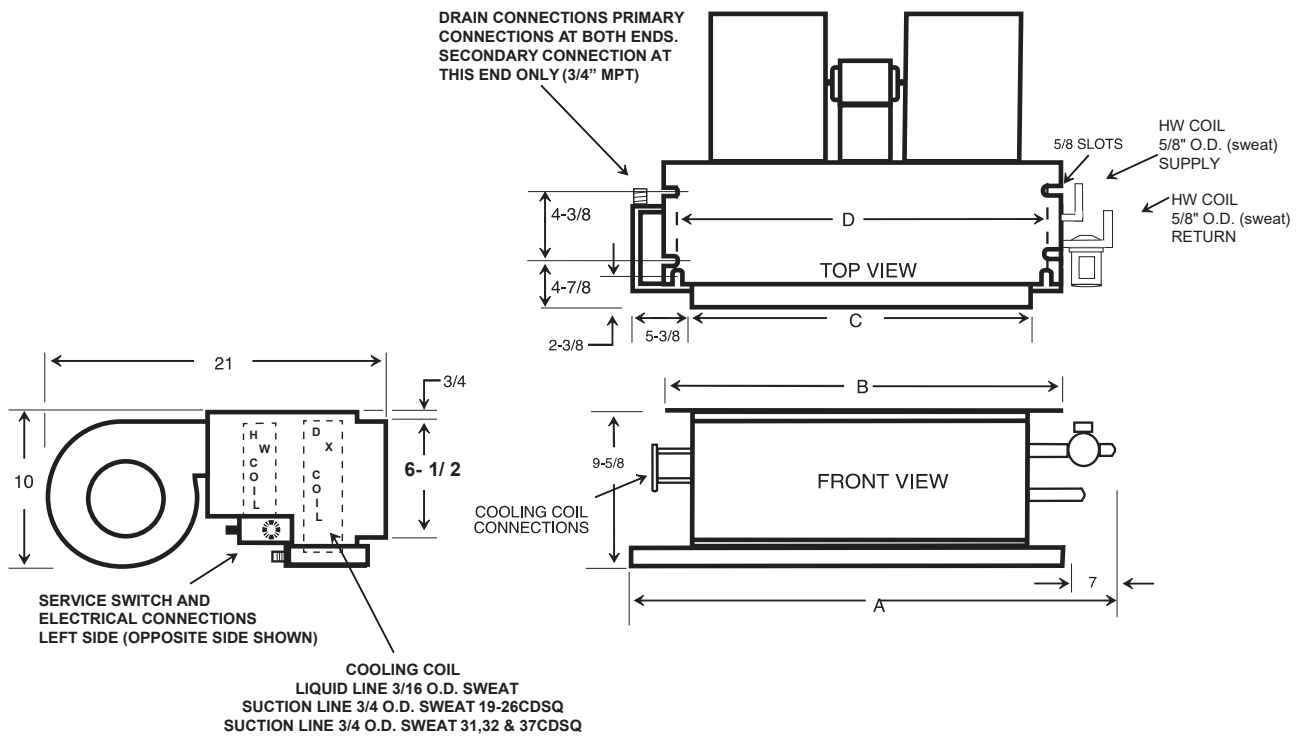
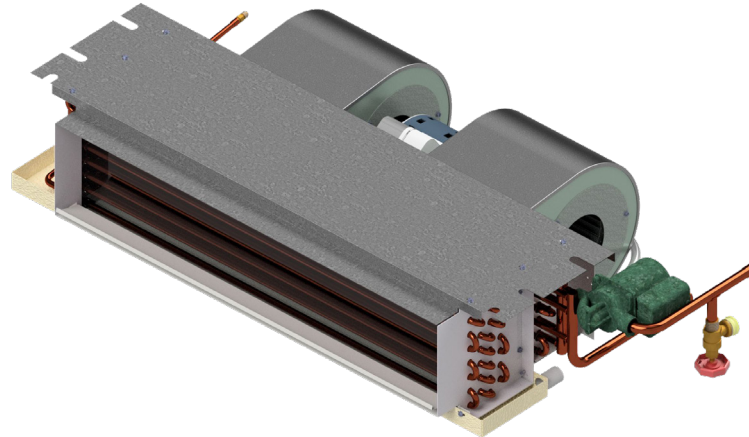

PHYSICAL DIMENSIONS				
UNIT MODEL	A	B	C	D
18/19CDXQ*	45-1/8	37-1/4	30-1/8	34-3/4
20/24/25CDXQ*	51-1/8	43-1/4	36-1/8	40-3/4
26/30/31CDXQ*	57-1/8	49-1/4	42-1/8	46-3/4
32/36/37CDXQ*	64-1/8	56-1/4	49-1/8	53-3/4

CDXQ

PSC MOTOR AND STANDARD PUMP

PERFORMANCE DATA CDXQ										
UNIT MODEL	NOMINAL COOLING BTUH	PRESS. DROP (FT. WTR)	BTUH (1000) AT ENTERING WATER TEMPERATURE Delta-T 20°F & GPM							
			120°F	GPM	130°F	GPM	140°F	GPM	180°F	GPM
18/19CDXQ*	18,000	3.3	12.9	1.3	15.4	1.5	18.0	1.8	28.3	2.8
20CDXQ*	18,000	4.1	13.7	1.4	16.5	1.7	19.2	1.9	30.2	3.0
24/25CDXQ*	24,000	4.1	15.9	1.6	19.0	1.9	22.2	2.2	34.9	3.5
26CDXQ*	24,000	4.3	17.0	1.7	20.4	2.0	23.8	2.4	37.4	3.7
30/31CDXQ*	30,000	4.3	18.8	1.9	22.5	2.3	26.3	2.6	41.3	4.1
32CDXQ*	30,000	5.4	20.1	2.0	24.2	2.4	28.2	2.8	44.3	4.4
36/37CDXQ*	36,000	5.4	21.7	2.2	26.1	2.6	30.4	3.0	47.8	4.8

NOTES:

1. Heat BTUH is at 70° F EAT.
2. 120° F and 180° F data is supplied for boiler applications.
3. Heating BTUH output will not exceed output of water heater.
4. Approved for installation with 0" clearance to combustible material.
5. Freeze protection on hot water and DX coils.
6. Based on 20° F Delta-T, Velocity not to exceed 4ft./sec.

ELECTRICAL DATA CDXQ					
UNIT MODEL	MOTOR HP (120V)	AMPS (120V)		MIN. CIR AMPACITY	MAX CIR PROTECTION
		MOTOR	PUMP		
18/19/20CDXQ*	1/5	2.3	0.57	4	15
24CDXQ*	1/5	3.0	0.57	5	15
25/26CDXQ*	1/4	3.6	0.57	6	15
30/31CDXQ*	1/5	4.6	0.57	7	15
32CDXQ*	1/5	4.6	0.57	7	15
36/37CDXQ*	1/5	4.6	0.57	7	15

CD SERIES

HOT WATER HEATING W/STANDARD PUMP & ECM MOTOR

CDXQX

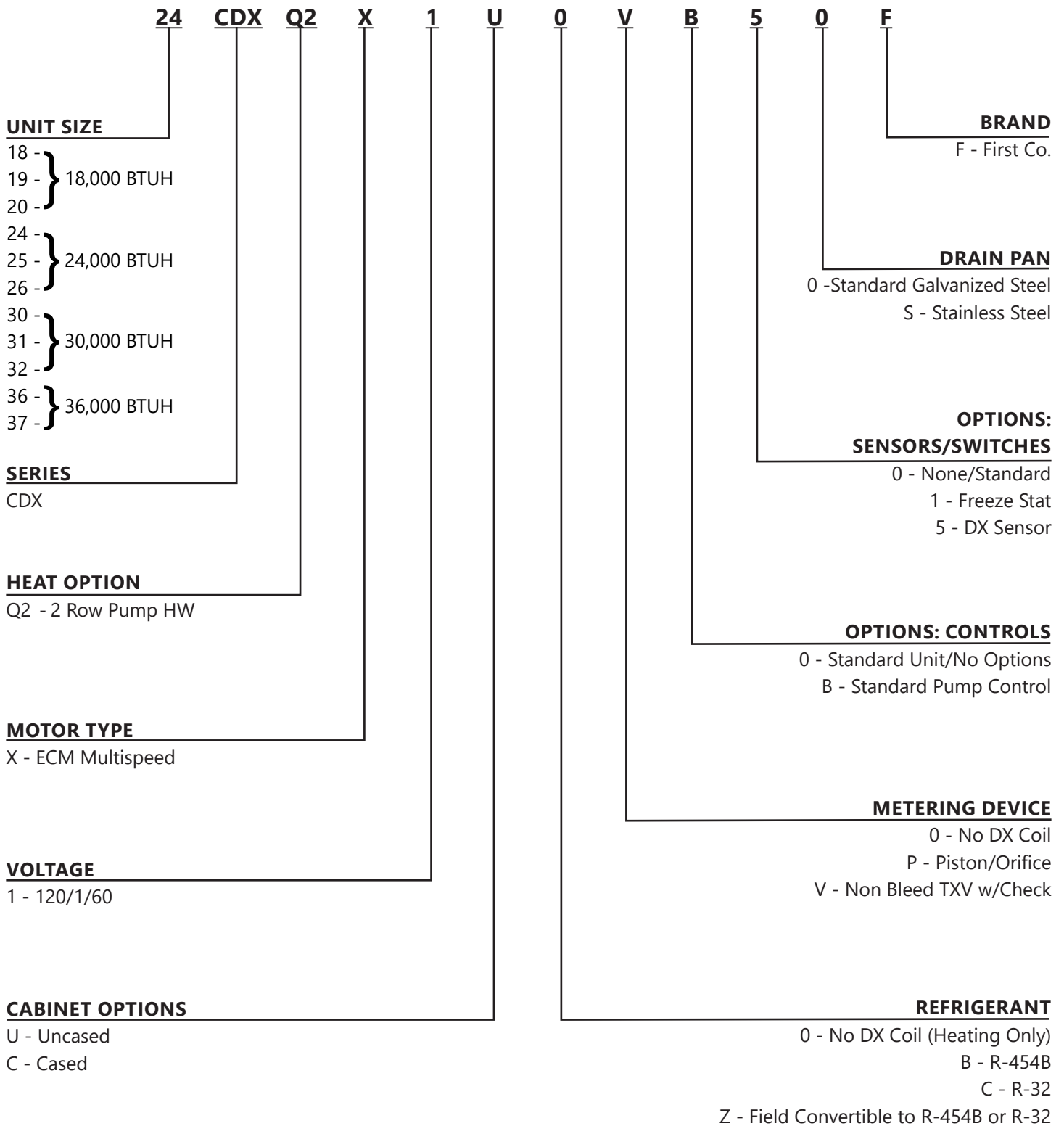

CD SERIES

HOT WATER HEATING W/STANDARD PUMP & ECM MOTOR

CDXQX

DATA TABLES

CDXQX

ECM MOTOR AND STANDARD PUMP

PERFORMANCE DATA CDXQX										
UNIT MODEL	NOMINAL COOLING BTUH	PRESS. DROP (FT. WTR)	BTUH (1000) AT ENTERING WATER TEMPERATURE Delta-T 20°F & GPM							
			120°F	GPM	130°F	GPM	140°F	GPM	180°F	GPM
18/19CDXQ*X	18,000	3.3	12.9	1.3	15.4	1.5	18.0	1.8	28.3	2.8
20CDXQ*X	18,000	4.1	13.7	1.4	16.5	1.7	19.2	1.9	30.2	3.0
24/25CDXQ*X	24,000	4.1	15.9	1.6	19.0	1.9	22.2	2.2	34.9	3.5
26CDXQ*X	24,000	4.3	17.0	1.7	20.4	2.0	23.8	2.4	37.4	3.7
30/31CDXQ*X	30,000	4.3	18.8	1.9	22.5	2.3	26.3	2.6	41.3	4.1
32CDXQ*X	30,000	5.4	20.1	2.0	24.2	2.4	28.2	2.8	44.3	4.4
36/37CDXQ*X	36,000	5.4	21.7	2.2	26.1	2.6	30.4	3.0	47.8	4.8

NOTES:

1. Heat BTUH is at 70° F EAT.
2. 120° F and 180° F data is supplied for boiler applications.
3. Heating BTUH output will not exceed output of water heater.
4. Approved for installation with 0" clearance to combustible material.
5. Freeze protection on hot water and DX coils.
6. Based on 20° F Delta-T, Velocity not to exceed 4ft./sec.

ELECTRICAL DATA CDXQX					
UNIT MODEL	MOTOR HP	AMPS		MIN. CIR AMPACITY	MAX CIR PROTECTION
		MOTOR	PUMP		
18/19/20CDXQ*X	1/2	7.0	0.57	10	15
24/25/26CDXQ*X	1/2	7.0	0.57	10	15
30/31CDXQ*X	1/2	7.0	0.57	10	15
32CDXQ*X	1/2	7.0	0.57	10	15
36/37CDXQ*X	1/2 (2)	7.0	0.57	17	20

CD SERIES

HI FLOW HEAT PUMP HOT WATER HEATING W/PSC MOTOR

CDXR

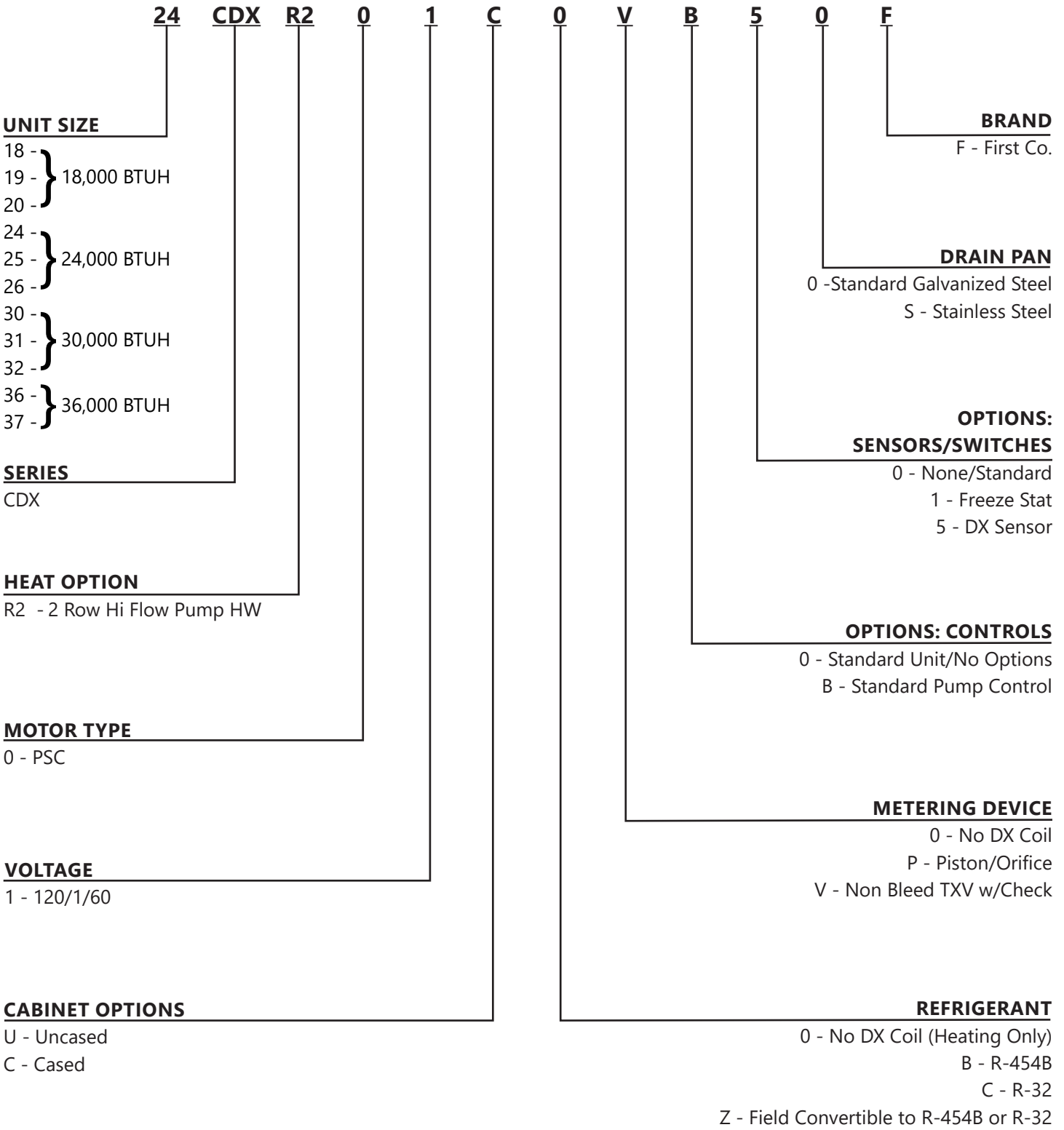

UNIT SIZE

- 18 - } 18,000 BTUH
- 19 - }
- 20 - }
- 24 - } 24,000 BTUH
- 25 - }
- 26 - }
- 30 - } 30,000 BTUH
- 31 - }
- 32 - }
- 36 - } 36,000 BTUH
- 37 - }

SERIES

CDX

HEAT OPTION

R2 - 2 Row Hi Flow Pump HW

MOTOR TYPE

0 - PSC

VOLTAGE

1 - 120/1/60

CABINET OPTIONS

- U - Uncased
- C - Cased

BRAND

F - First Co.

DRAIN PAN

- 0 - Standard Galvanized Steel
- S - Stainless Steel

OPTIONS:

SENSORS/SWITCHES

- 0 - None/Standard
- 1 - Freeze Stat
- 5 - DX Sensor

OPTIONS: CONTROLS

- 0 - Standard Unit/No Options
- B - Standard Pump Control

METERING DEVICE

- 0 - No DX Coil
- P - Piston/Orifice
- V - Non Bleed TXV w/Check

REFRIGERANT

- 0 - No DX Coil (Heating Only)
- B - R-454B
- C - R-32
- Z - Field Convertible to R-454B or R-32

CD SERIES

HI FLOW HEAT PUMP HOT WATER HEATING W/PSC MOTOR

CDXR

DATA TABLES

CDXR

PSC MOTOR AND HI FLOW PUMP

The CDXR series fan coils are designed specifically for use with tankless water heaters. These fan coils allow high efficiency tankless water heaters to be used for two jobs instead of one... providing domestic hot water and high efficiency space heating! They are compatible with most of today's higher efficiency split-systems heat pumps and condensing units .

The CDXR fan coils include a special circulating pump designed for tankless heaters, HW check valve, air purge valve, hot water coil, cooling coil, blower/motor, and multi-function circuit board. The fan coil with the -C is factory installed within an insulated enclosure or "case" and is shipped with your choice of either a solid or louvered access panel with attractive off-white powder coat finish. Solid panels must be used with ducted return air applications, while louvered panels (the default style) should be used with non-ducted return air applications. Louvered panels include filters, but solid panels require field supplied return-air filter/louvers.

PERFORMANCE DATA CDXR*										
UNIT MODEL	NOMINAL COOLING BTUH	PRESS. DROP (FT. WTR)	BTUH (1000) AT ENTERING WATER TEMPERATURE Delta-T 20°F & GPM							
			120°F	GPM	130°F	GPM	140°F	GPM	180°F	GPM
18/19CDXR*	18,000	3.3	12.9	1.3	15.4	1.5	18.0	1.8	28.3	2.8
20CDXR*	18,000	4.1	13.7	1.4	16.5	1.7	19.2	1.9	30.2	3.0
24/25CDXR*	24,000	4.1	15.9	1.6	19.0	1.9	22.2	2.2	34.9	3.5
26CDXR*	24,000	4.3	17.0	1.7	20.4	2.0	23.8	2.4	37.4	3.7
30/31CDXR*	30,000	4.3	18.8	1.9	22.5	2.3	26.3	2.6	41.3	4.1
32CDXR*	30,000	5.4	20.1	2.0	24.2	2.4	28.2	2.8	44.3	4.4
36/37CDXR*	36,000	5.4	21.7	2.2	26.1	2.6	30.4	3.0	47.8	4.8

NOTES:

1. Heat BTUH is at 70° F EAT.
2. 120° F and 180° F data is supplied for boiler applications.
3. Heating BTUH output will not exceed output of water heater.
4. Approved for installation with 0" clearance to combustible material.
5. Freeze protection on hot water and DX coils.
6. Based on 20° F Delta-T, Velocity not to exceed 4ft./sec.

ELECTRICAL DATA CDXR*					
UNIT MODEL	MOTOR HP (120V)	AMPS (120V)		MIN. CIR AMPACITY	MAX CIR PROTECTION
		MOTOR	PUMP		
18/19/20CDXR*	1/5	2.3	0.84	4	15
24/25/26CDXR*	1/4	3.6	0.84	6	15
30/31CDXR*	1/5 (2)	4.6	0.84	7	15
32CDXR*	1/5 (2)	4.6	0.84	7	15
36/37CDXR*	1/5 (2)	4.6	0.84	7	15

CD SERIES

HI FLOW HEAT PUMP HOT WATER HEATING W/ECM MOTOR

CDXRX

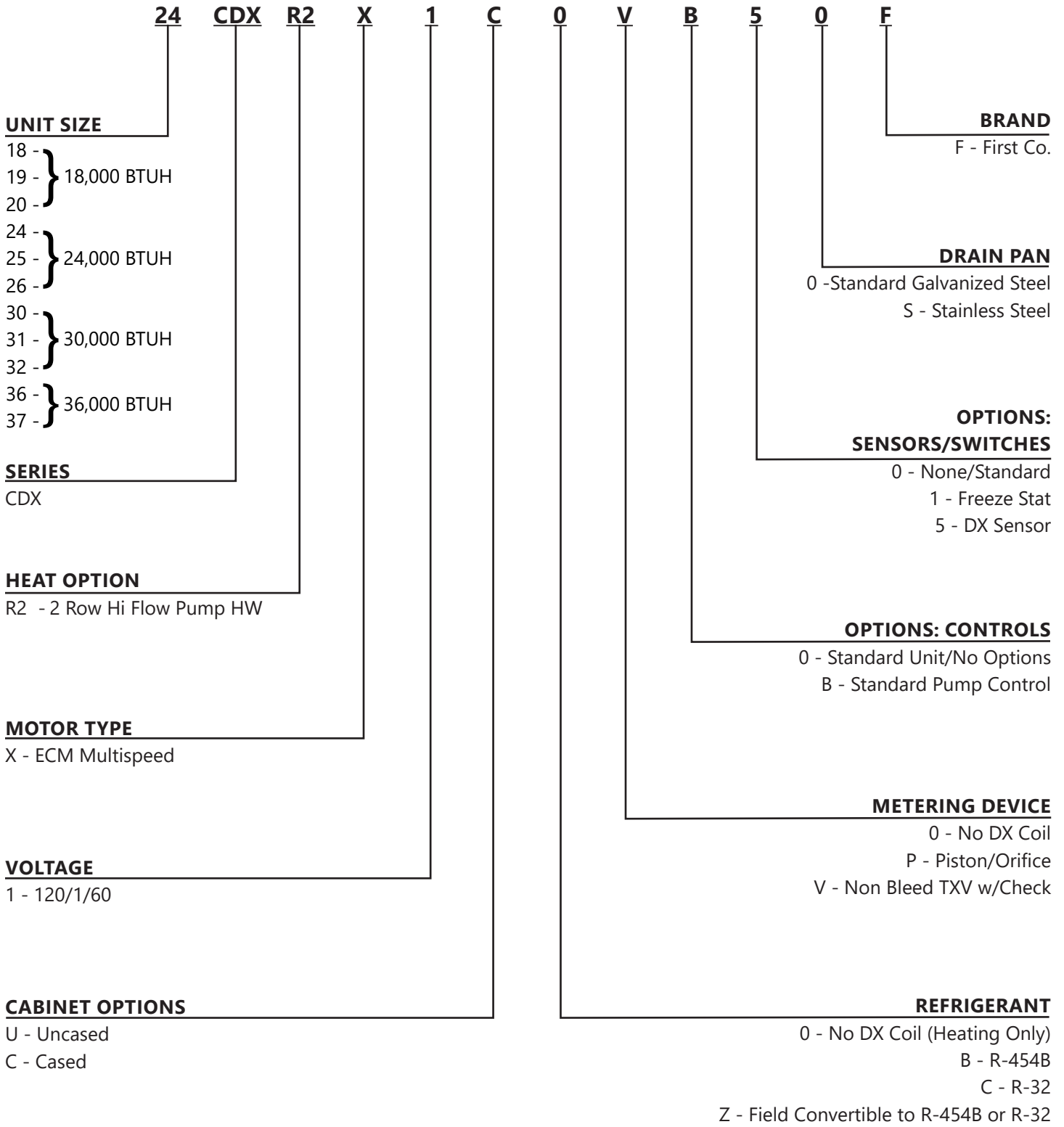

CD SERIES

HI FLOW HEAT PUMP HOT WATER HEATING W/ECM MOTOR

CDXR^X

DATA TABLES

CDXR^X

ECM MOTOR AND HI FLOW PUMP

PERFORMANCE DATA CDXR* X										
UNIT MODEL	NOMINAL COOLING BTUH	PRESS. DROP (FT. WTR)	BTUH (1000) AT ENTERING WATER TEMPERATURE Delta-T 20°F & GPM							
			120°F	GPM	130°F	GPM	140°F	GPM	180°F	GPM
18/19CDXR*X	18,000	3.3	12.9	1.3	15.4	1.5	18.0	1.8	28.3	2.8
20CDXR*X	18,000	4.1	13.7	1.4	16.5	1.7	19.2	1.9	30.2	3.0
24/25CDXR*X	24,000	4.1	15.9	1.6	19.0	1.9	22.2	2.2	34.9	3.5
26CDXR*X	24,000	4.3	17.0	1.7	20.4	2.0	23.8	2.4	37.4	3.7
30/31CDXR*X	30,000	4.3	18.8	1.9	22.5	2.3	26.3	2.6	41.3	4.1
32CDXR*X	30,000	5.4	20.1	2.0	24.2	2.4	28.2	2.8	44.3	4.4
36/37CDXR*X	36,000	5.4	21.7	2.2	26.1	2.6	30.4	3.0	47.8	4.8

NOTES:

1. Heat BTUH is at 70° F EAT.
2. 120° F and 180° F data is supplied for boiler applications.
3. Heating BTUH output will not exceed output of water heater.
4. Approved for installation with 0" clearance to combustible material.
5. Freeze protection on hot water and DX coils.
6. Based on 20° F Delta-T, Velocity not to exceed 4ft./sec.

ELECTRICAL DATA CDXR* X					
UNIT MODEL	MOTOR HP	AMPS		MIN. CIR AMPACITY	MAX CIR PROTECTION
		MOTOR	PUMP		
18/19/20CDXR*X	1/2	7.0	.84	10	15
24/25/26CDXR*X	1/2	7.0	.84	10	15
30/31CDXR*X	1/2	7.0	.84	10	15
32CDXR*X	1/2	7.0	.84	10	15
36/37CDXR*X	1/2 (2)	7.0	.84	17	20

CDS SERIES

HOT WATER COIL W/PSC MOTOR, NO PUMP

CDSW

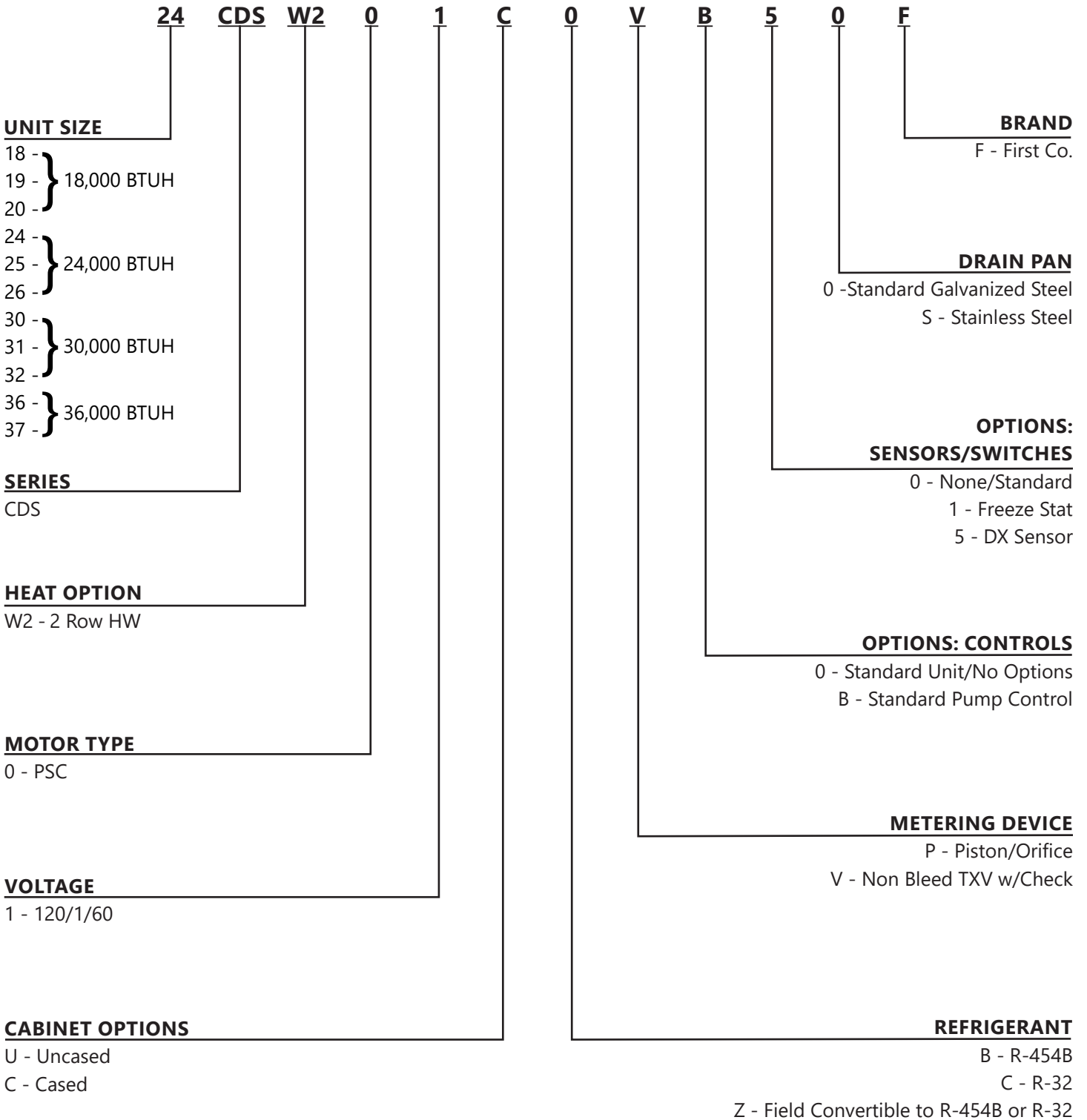

CDS SERIES

HOT WATER COIL W/PSC MOTOR, NO PUMP

CDSW

DATA TABLE

CDS SERIES – WITH HOT WATER COILS

PSC MOTOR WITH HOT WATER COILS, NO PUMP

PERFORMANCE DATA CDSW								
UNIT MODEL	NOMINAL COOLING BTUH	PRESS. DROP (FT. WTR)	BTUH (1000) AT ENTERING WATER TEMPERATURE Delta -T 20°F & GPM					
			120°F	GPM	140°F	GPM	180°F	GPM
18/19CDSW	18,000	0.7	10.3	1.0	14.4	1.4	22.6	2.3
		2.0	12.0	1.2	16.8	1.7	26.4	2.6
		3.3	12.9	1.3	18.0	1.8	28.3	2.8
20CDSW	18,000	0.8	10.9	1.1	15.3	1.5	24.0	2.4
		2.1	12.9	1.3	18.0	1.8	28.3	2.8
		4.1	13.7	1.4	19.2	1.9	30.2	3.0
24/25CDSW	24,000	2.1	14.7	1.5	20.6	2.1	32.4	3.2
		4.1	15.9	1.6	22.2	2.2	34.9	3.5
		6.6	16.5	1.7	23.1	2.3	36.3	3.6
26CDSW	24,000	2.2	15.7	1.6	22.0	2.2	34.6	3.5
		4.3	17.0	1.7	23.8	2.4	37.4	3.7
		6.8	17.6	1.8	24.7	2.5	38.8	3.9
30/31CDSW	30,000	2.2	17.3	1.7	24.2	2.4	38.0	3.8
		4.3	18.8	1.9	26.3	2.6	41.3	4.1
		6.8	19.6	2.0	27.5	2.8	43.2	4.3
32CDSW	30,000	2.8	18.4	1.8	25.8	2.6	40.5	4.1
		5.4	20.1	2.0	28.2	2.8	44.3	4.4
		8.5	21.1	2.1	29.5	3.0	46.4	4.6
36/37CDSW	36,000	2.8	19.7	2.0	27.6	2.8	43.4	4.3
		5.4	21.7	2.2	30.4	3.0	47.8	4.8
		8.5	22.8	2.3	31.9	3.2	50.1	5.0

NOTES:

1. Heat BTUH is at 70°F EAT.
2. Based on 20°F Delta - T. Velocity not to exceed 4ft./sec.
3. 120 degree and 180 degree data is supplied for boiler applications.
4. Heating BTUH output will not exceed output of water heater.
5. Approved for installation with 0" clearance to combustible material.
6. Use capacities when First Co. "Flow Control Module" is used (# 940-3CV).
7. Freeze protection standard on hot water and DX coils.

ELECTRICAL DATA CDSW					
UNIT MODEL	MOTOR (1)		MOTOR HP (120V)	MIN. CKT. AMPACITY (120V)	MAX. CKT. PROTECTION
	RPM	AMPS			
18/19/20CDSW	1550	2.3	1/5	3	15
24/25/26CDSW	1550	3.6	1/4	5	15
30/31CDSW	1550	4.6	1/5	6	15
32CDSW	1550	4.6	1/5	6	15
36/37CDSW	1550	4.6	1/5	6	15

CDS SERIES

HOT WATER COIL W/ECM MOTOR, NO PUMP

CDSWX

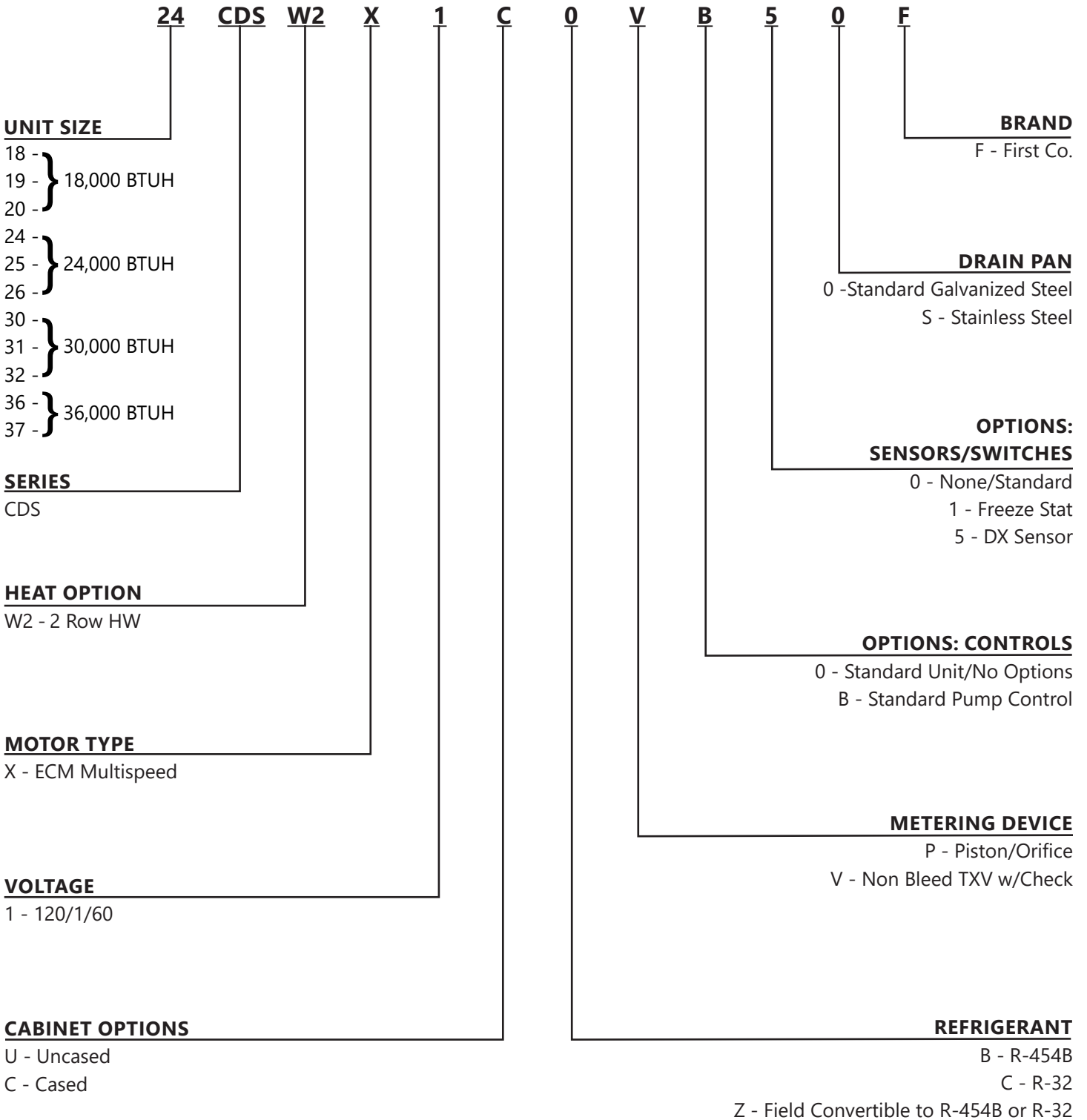

CDS SERIES

HOT WATER COIL W/ECM MOTOR, NO PUMP

CDSWX

DATA TABLES

CDS SERIES - WITH HOT WATER COILS

ECM MOTOR WITH HOT WATER COILS, NO PUMP

PERFORMANCE DATA CDSWX								
UNIT MODEL	NOMINAL COOLING BTUH	PRESS. DROP (FT. WTR)	BTUH (1000) AT ENTERING WATER TEMPERATURE Delta-T-20°F & GPM					
			120°F	GPM	140°F	GPM	180°F	GPM
18/19CDSWX	18,000	0.7	10.3	1.0	14.4	1.4	22.6	2.3
		2.0	12.0	1.2	16.8	1.7	26.4	2.6
		3.3	12.9	1.3	18.0	1.8	28.3	2.8
20CDSWX	18,000	0.8	10.9	1.1	15.3	1.5	24.0	2.4
		2.1	12.9	1.3	18.0	1.8	28.3	2.8
		4.1	13.7	1.4	19.2	1.9	30.2	3.0
24/25CDSWX	24,000	2.1	14.7	1.5	20.6	2.1	32.4	3.2
		4.1	15.9	1.6	22.2	2.2	34.9	3.5
		6.6	16.5	1.7	23.1	2.3	36.3	3.6
26CDSWX	24,000	2.2	15.7	1.7	22.0	2.4	34.6	3.8
		4.3	17.0	1.9	23.8	2.6	37.4	4.1
		6.8	17.6	2.0	24.7	2.8	38.8	4.3
30/31CDSWX	30,000	2.2	17.3	1.7	24.2	2.4	38.0	3.8
		4.3	18.8	1.9	26.3	2.6	41.3	4.1
		6.8	19.6	2.0	27.5	2.8	43.2	4.3
32CDSWX	30,000	2.8	18.4	1.8	25.8	2.6	40.5	4.1
		5.4	20.1	2.0	28.2	2.8	44.3	4.4
		8.5	21.1	2.1	29.5	3.0	46.4	4.6
36/37CDSWX	36,000	2.8	19.7	2.0	27.6	2.8	43.4	4.3
		5.4	21.7	2.2	30.4	3.0	47.8	4.8
		8.5	22.8	2.3	31.9	3.2	50.1	5.0

NOTES:

1. Heat BTUH is at 70°F EAT.
2. Based on 20°F Delta - T. Velocity not to exceed 4ft./sec.
3. 120 degree and 180 degree data is supplied for boiler applications.
4. Heating BTUH output will not exceed output of water heater.
5. Approved for installation with 0" clearance to combustibile material.
6. Use capacities when First Co. "Flow Control Module" is used (# 940-3CV).
7. Freeze protection standard on hot water and DX coils.

ELECTRICAL DATA CDSWX				
UNIT MODEL	MOTOR HP	AMPS	MIN. CIR AMPACITY	MAX CIR PROTECTION
		MOTOR		
18/19/20CDSWX	1/2	7.0	9	15
24/25/26CDSWX	1/2	7.0	9	15
30/31CDSWX	1/2	7.0	9	15
32CDSWX	1/2	7.0	9	15
36/37CDSWX	1/2 (2)	7.0	16	20

CDS SERIES

HOT WATER HEATING W/STANDARD PUMP & PSC MOTOR

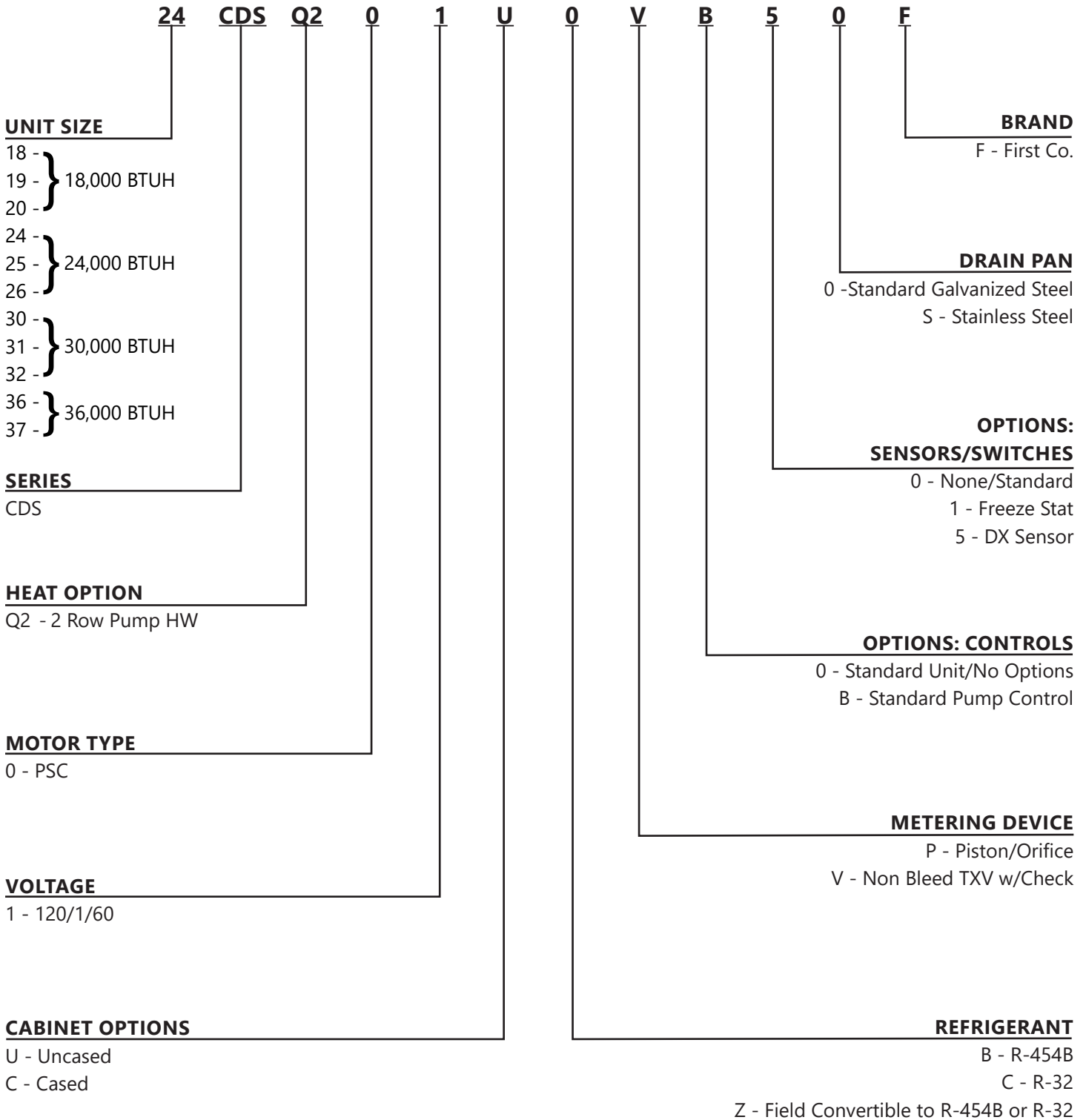

PHYSICAL DIMENSIONS

UNCASED VERSION WITH STANDARD PUMP

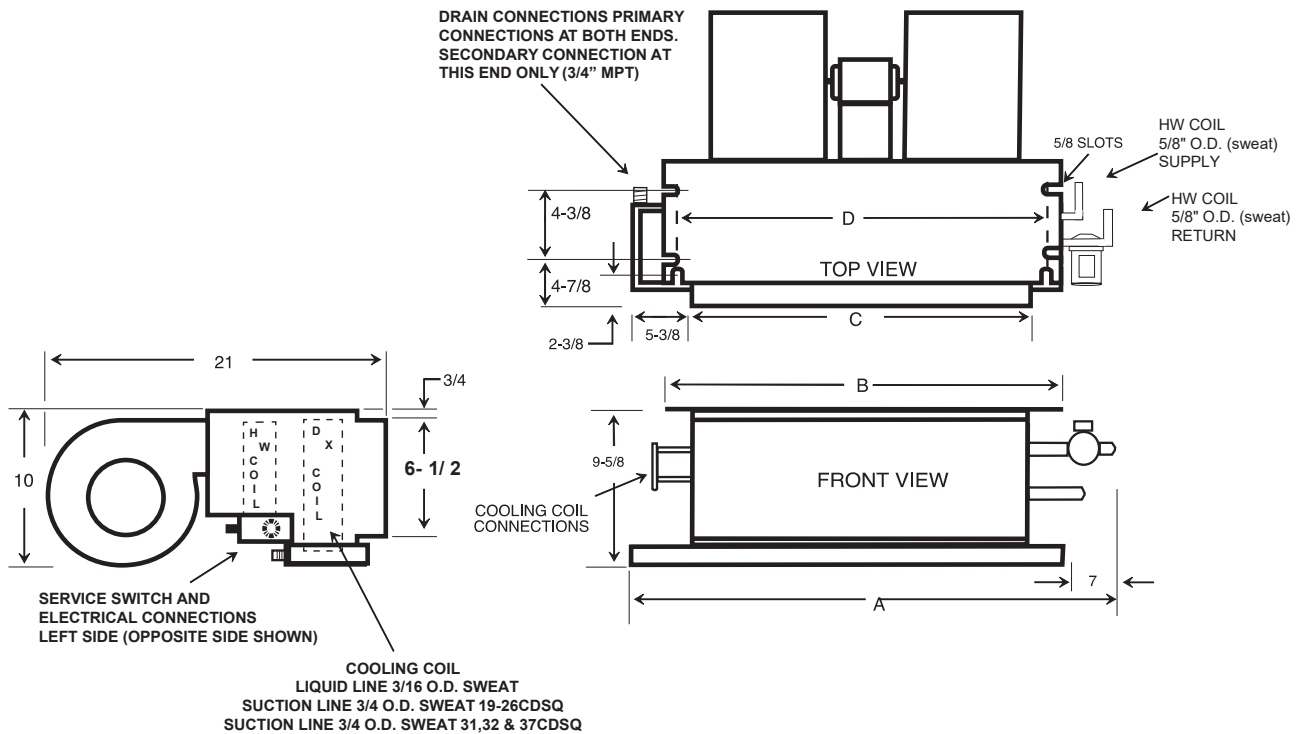
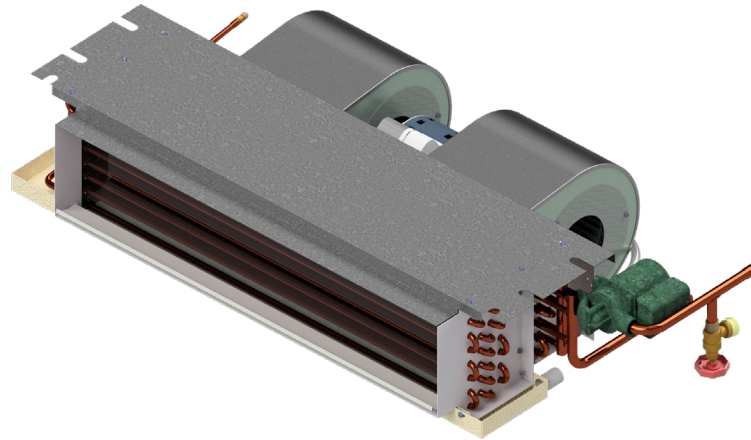

PHYSICAL DIMENSIONS				
UNIT MODEL	A	B	C	D
18/19CDSQ*	45-1/8	37-1/4	30-1/8	34-3/4
20/24/25CDSQ*	51-1/8	43-1/4	36-1/8	40-3/4
26/30/31CDSQ*	57-1/8	49-1/4	42-1/8	46-3/4
32/36/37CDSQ*	64-1/8	56-1/4	49-1/8	53-3/4

CDSQ

PSC MOTOR AND STANDARD PUMP

PERFORMANCE DATA CDSQ										
UNIT MODEL	NOMINAL COOLING BTUH	PRESS. DROP (FT. WTR)	BTUH (1000) AT ENTERING WATER TEMPERATURE Delta-T 20°F & GPM							
			120°F	GPM	130°F	GPM	140°F	GPM	180°F	GPM
18/19CDSQ*	18,000	3.3	12.9	1.3	15.4	1.5	18.0	1.8	28.3	2.8
20CDSQ*	18,000	4.1	13.7	1.4	16.5	1.7	19.2	1.9	30.2	3.0
24/25CDSQ*	24,000	4.1	15.9	1.6	19.0	1.9	22.2	2.2	34.9	3.5
26CDSQ*	24,000	4.3	17.0	1.7	20.4	2.0	23.8	2.4	37.4	3.7
30/31CDSQ*	30,000	4.3	18.8	1.9	22.5	2.3	26.3	2.6	41.3	4.1
32CDSQ*	30,000	5.4	20.1	2.0	24.2	2.4	28.2	2.8	44.3	4.4
36/37CDSQ*	36,000	5.4	21.7	2.2	26.1	2.6	30.4	3.0	47.8	4.8

NOTES:

1. Heat BTUH is at 70°F EAT.
2. 120°F and 180°F data is supplied for boiler applications.
3. Heating BTUH output will not exceed output of water heater.
4. Approved for installation with 0" clearance to combustible material.
5. Freeze protection on hot water and DX coils.
6. Based on 20°F Delta-T, Velocity not to exceed 4ft./sec.

ELECTRICAL DATA CDSQ					
UNIT MODEL	MOTOR HP (120V)	AMPS (120V)		MIN. CIR AMPACITY	MAX CIR PROTECTION
		MOTOR	PUMP		
18/19/20CDSQ*	1/5	2.3	0.57	4	15
24CDSQ*	1/5	3.0	0.57	5	15
25/26CDSQ*	1/4	3.6	0.57	6	15
30/31CDSQ*	1/5	4.6	0.57	7	15
32CDSQ*	1/5	4.6	0.57	7	15
36/37CDSQ*	1/5	4.6	0.57	7	15

CDS SERIES

HOT WATER HEATING W/STANDARD PUMP & ECM MOTOR

CDSQX

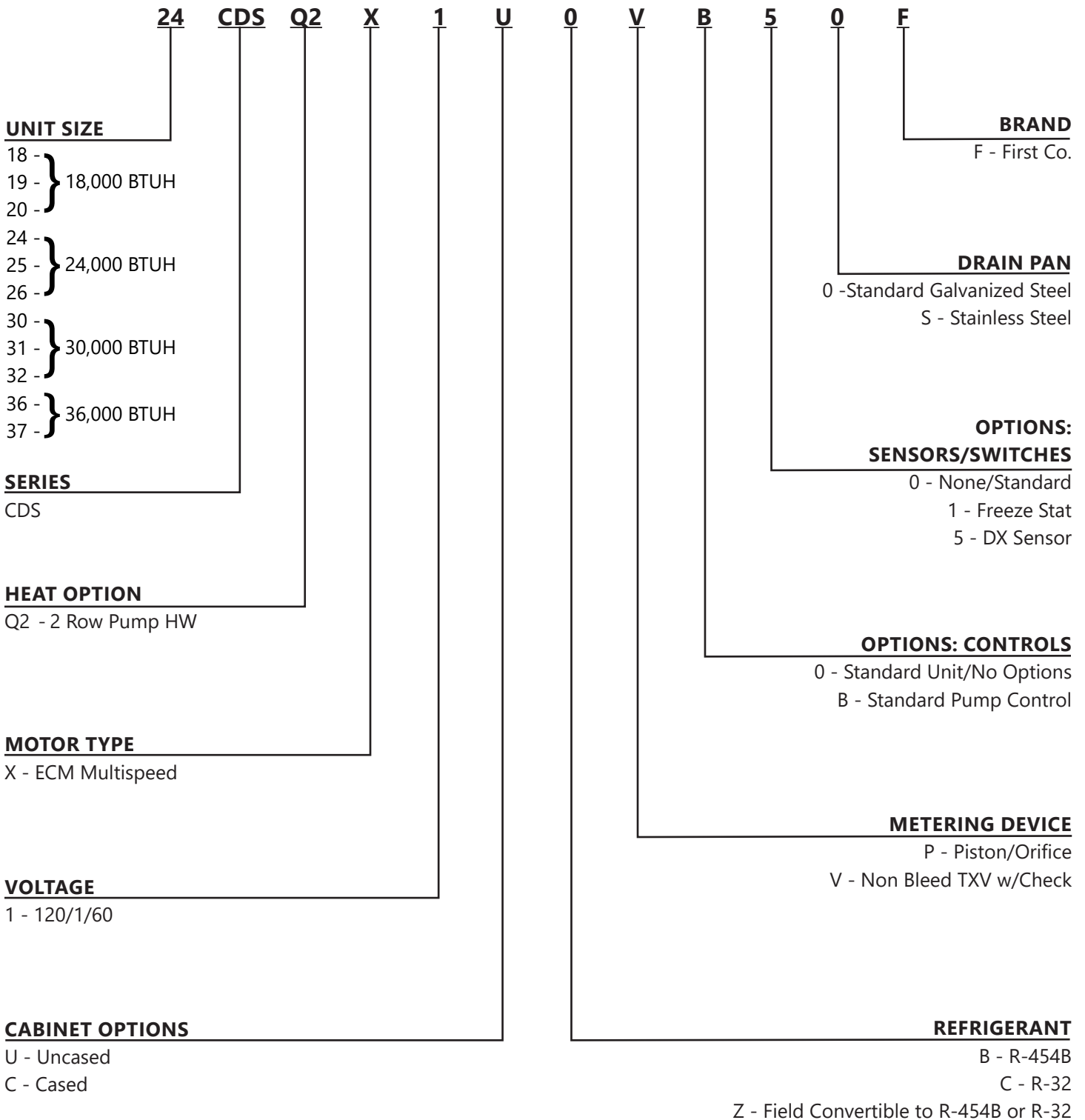

CDSQX

ECM MOTOR AND STANDARD PUMP

PERFORMANCE DATA CDSQX										
UNIT MODEL	NOMINAL COOLING BTUH	PRESS. DROP (FT. WTR)	BTUH (1000) AT ENTERING WATER TEMPERATURE Delta-T 20°F & GPM							
			120°F	GPM	130°F	GPM	140°F	GPM	180°F	GPM
18/19CDSQ*X	18,000	3.3	12.9	1.3	15.4	1.5	18.0	1.8	28.3	2.8
20CDSQ*X	18,000	4.1	13.7	1.4	16.5	1.7	19.2	1.9	30.2	3.0
24/25CDSQ*X	24,000	4.1	15.9	1.6	19.0	1.9	22.2	2.2	34.9	3.5
26CDSQ*X	24,000	4.3	17.0	1.7	20.4	2.0	23.8	2.4	37.4	3.7
30/31CDSQ*X	30,000	4.3	18.8	1.9	22.5	2.3	26.3	2.6	41.3	4.1
32CDSQ*X	30,000	5.4	20.1	2.0	24.2	2.4	28.2	2.8	44.3	4.4
36/37CDSQ*X	36,000	5.4	21.7	2.2	26.1	2.6	30.4	3.0	47.8	4.8

NOTES:

1. Heat BTUH is at 70°F EAT.
2. 120°F and 180°F data is supplied for boiler applications.
3. Heating BTUH output will not exceed output of water heater.
4. Approved for installation with 0" clearance to combustible material.
5. Freeze protection on hot water and DX coils.
6. Based on 20°F Delta-T, Velocity not to exceed 4ft./sec.

ELECTRICAL DATA CDSQX					
UNIT MODEL	MOTOR HP	AMPS		MIN. CIR AMPACITY	MAX CIR PROTECTION
		MOTOR	PUMP		
18/19/20CDSQ*X	1/2	7.0	0.57	10	15
24/25/26CDSQ*X	1/2	7.0	0.57	10	15
30/31CDSQ*X	1/2	7.0	0.57	10	15
32CDSQ*X	1/2	7.0	0.57	10	15
36/37CDSQ*X	1/2 (2)	7.0	0.57	17	20

CDS SERIES

HI FLOW HEAT PUMP HOT WATER HEATING W/PSC MOTOR

CDSR

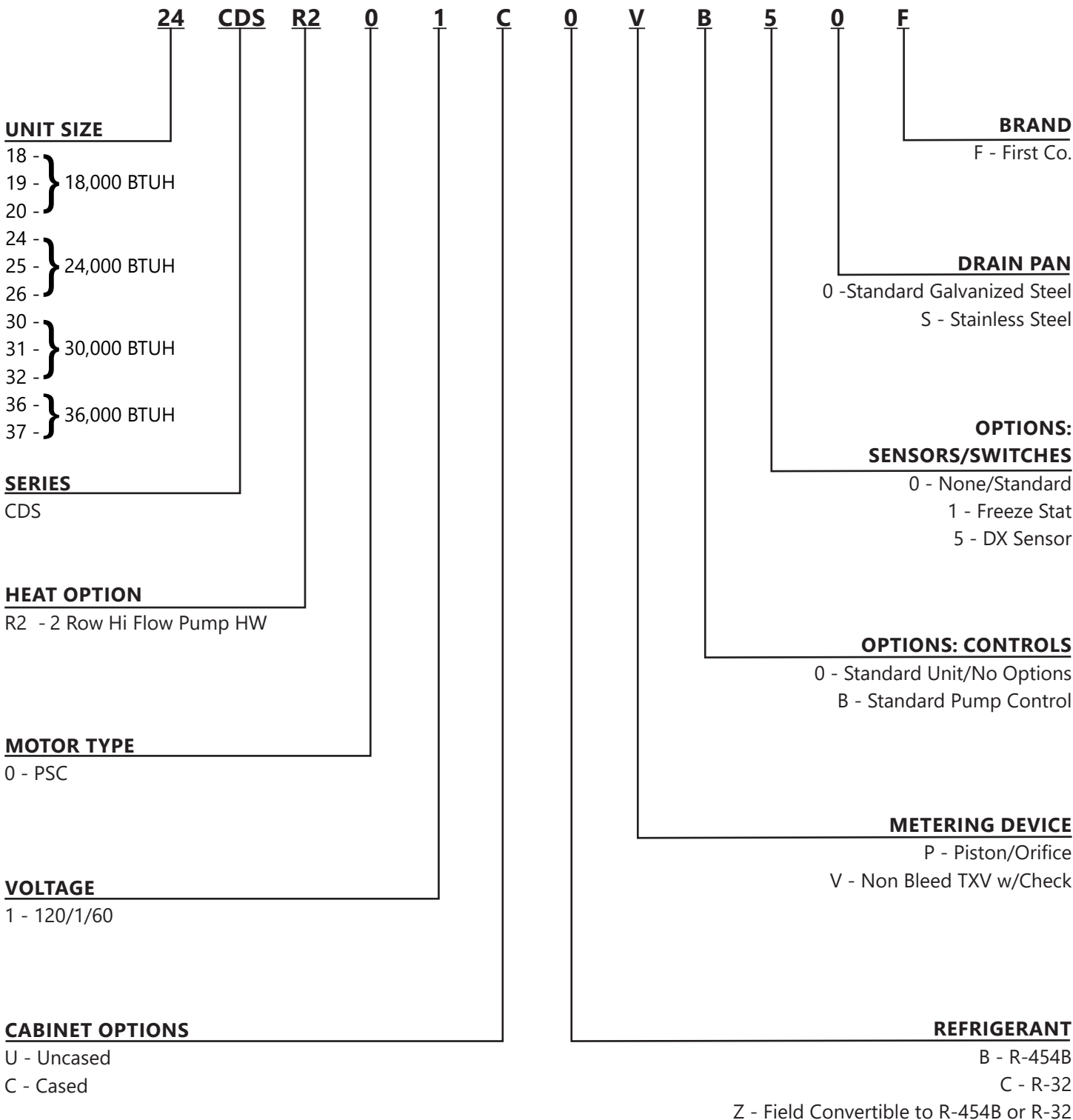

CDS SERIES

HI FLOW HEAT PUMP HOT WATER HEATING W/PSC MOTOR

CDSR PSC MOTOR AND HI FLOW PUMP

The CDSR series fan coils are designed specifically for use with tankless water heaters. These fan coils allow high efficiency tankless water heaters to be used for two jobs instead of one.... providing domestic hot water and high efficiency space heating! They are compatible with most of today's higher efficiency split-systems heat pumps and condensing units .

The CDSR fan coils include a special circulating pump designed for tankless heaters, HW check valve, air purge valve, hot water coil, cooling coil, blower/motor, and multi-function circuit board. The fan coil with the -C is factory installed within an insulated enclosure or "case" and is shipped with your choice of either a solid or louvered access panel with attractive off-white powder coat finish. Solid panels must be used with ducted return air applications, while louvered panels (the default style) should be used with non-ducted return air applications. Louvered panels include filters, but solid panels require field supplied return-air filter/louvers.

PERFORMANCE DATA CDSR*										
UNIT MODEL	NOMINAL COOLING BTUH	PRESS. DROP (FT. WTR)	BTUH (1000) AT ENTERING WATER TEMPERATURE Delta-T 20°F & GPM							
			120°F	GPM	130°F	GPM	140°F	GPM	180°F	GPM
18/19CDSR*	18,000	3.3	12.9	1.3	15.4	1.5	18.0	1.8	28.3	2.8
20CDSR*	18,000	4.1	13.7	1.4	16.5	1.7	19.2	1.9	30.2	3.0
24/25CDSR*	24,000	4.1	15.9	1.6	19.0	1.9	22.2	2.2	34.9	3.5
26CDSR*	24,000	4.3	17.0	1.7	20.4	2.0	23.8	2.4	37.4	3.7
30/31CDSR*	30,000	4.3	18.8	1.9	22.5	2.3	26.3	2.6	41.3	4.1
32CDSR*	30,000	5.4	20.1	2.0	24.2	2.4	28.2	2.8	44.3	4.4
36/37CDSR*	36,000	5.4	21.7	2.2	26.1	2.6	30.4	3.0	47.8	4.8

NOTES:

1. Heat BTUH is at 70°F EAT.
2. 120°F and 180°F data is supplied for boiler applications.
3. Heating BTUH output will not exceed output of water heater.
4. Approved for installation with 0" clearance to combustible material.
5. Freeze protection on hot water and DX coils.
6. Based on 20°F Delta-T, Velocity not to exceed 4ft./sec.

ELECTRICAL DATA CDSR*					
UNIT MODEL	MOTOR HP (120V)	AMPS (120V)		MIN. CIR AMPACITY	MAX CIR PROTECTION
		MOTOR	PUMP		
18/19/20CDSR*	1/5	2.3	0.84	4	15
24/25/26CDSR*	1/4	3.6	0.84	6	15
30/31CDSR*	1/5 (2)	4.6	0.84	7	15
32CDSR*	1/5 (2)	4.6	0.84	7	15
36/37CDSR*	1/5 (2)	4.6	0.84	7	15

CDS SERIES

HI FLOW HEAT PUMP HOT WATER HEATING W/ECM MOTOR

CDSRX

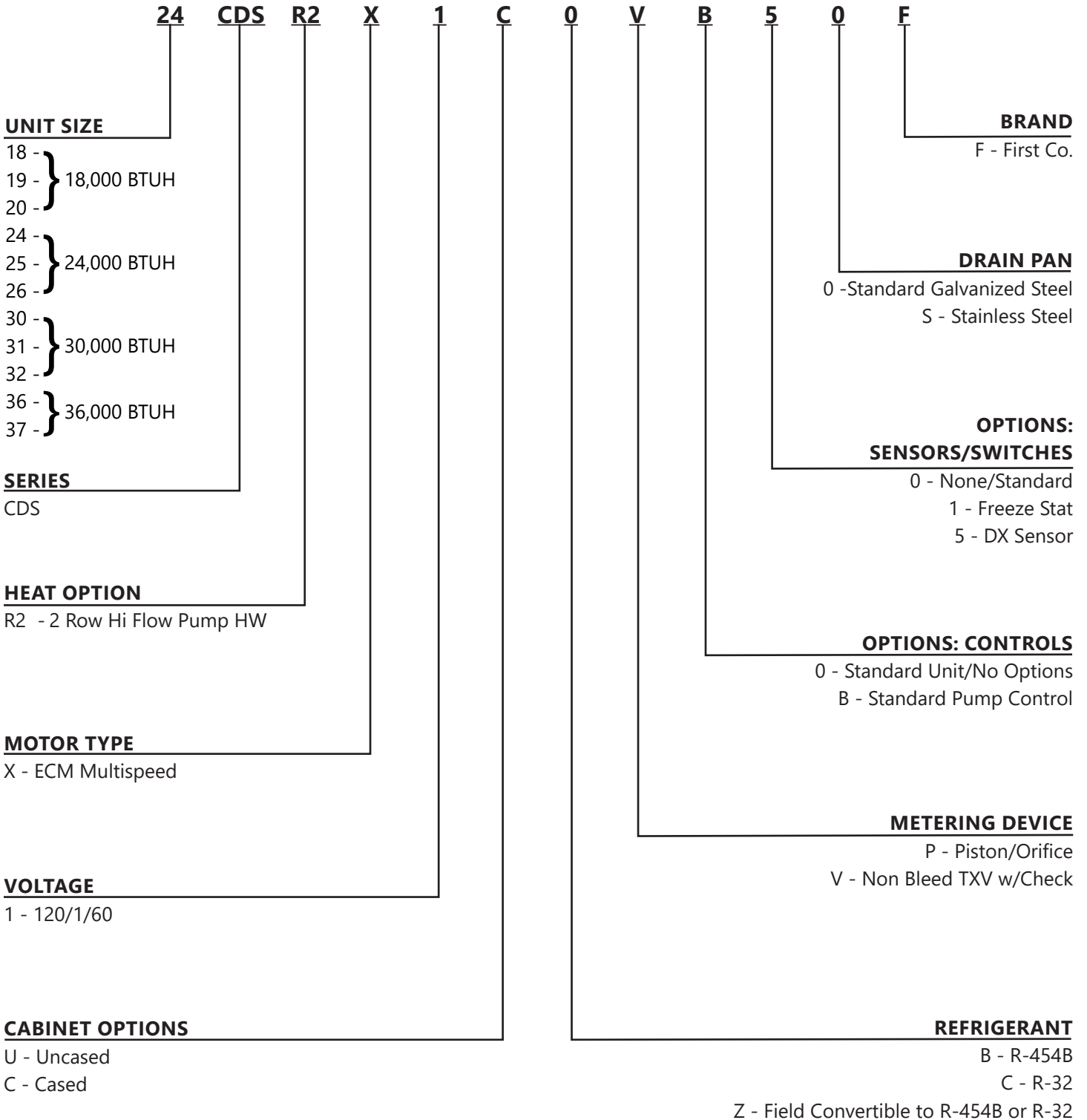

CDS SERIES

HI FLOW HEAT PUMP HOT WATER HEATING W/ECM MOTOR

CDSRX

DATA TABLES

CDSRX

ECM MOTOR AND HI FLOW PUMP

PERFORMANCE DATA CDSR* X										
UNIT MODEL	NOMINAL COOLING BTUH	PRESS. DROP (FT. WTR)	BTUH (1000) AT ENTERING WATER TEMPERATURE Delta-T 20°F & GPM							
			120°F	GPM	130°F	GPM	140°F	GPM	180°F	GPM
18/19CDSR*X	18,000	3.3	12.9	1.3	15.4	1.5	18.0	1.8	28.3	2.8
20CDSR*X	18,000	4.1	13.7	1.4	16.5	1.7	19.2	1.9	30.2	3.0
24/25CDSR*X	24,000	4.1	15.9	1.6	19.0	1.9	22.2	2.2	34.9	3.5
26CDSR*X	24,000	4.3	17.0	1.7	20.4	2.0	23.8	2.4	37.4	3.7
30/31CDSR*X	30,000	4.3	18.8	1.9	22.5	2.3	26.3	2.6	41.3	4.1
32CDSR*X	30,000	5.4	20.1	2.0	24.2	2.4	28.2	2.8	44.3	4.4
36/37CDSR*X	36,000	5.4	21.7	2.2	26.1	2.6	30.4	3.0	47.8	4.8

NOTES:

1. Heat BTUH is at 70°F EAT.
2. 120°F and 180°F data is supplied for boiler applications.
3. Heating BTUH output will not exceed output of water heater.
4. Approved for installation with 0" clearance to combustible material.
5. Freeze protection on hot water and DX coils.
6. Based on 20°F Delta-T, Velocity not to exceed 4ft./sec.

ELECTRICAL DATA CDSR*X					
UNIT MODEL	MOTOR HP	AMPS		MIN. CIR AMPACITY	MAX CIR PROTECTION
		MOTOR	PUMP		
18/19/20CDSR*X	1/2	7.0	.84	10	15
24/25/26CDSR*X	1/2	7.0	.84	10	15
30/31CDSR*X	1/2	7.0	.84	10	15
32CDSR*X	1/2	7.0	.84	10	15
36/37CDSR*X	1/2 (2)	7.0	.84	17	20

SPECIFICATION GUIDE

UNIT

- All fan coils are manufactured with 20 to 22 gauge galvanized steel to resist corrosion.
- All units are approved for installation with "0" clearance to combustible material.
- Piping, drain, and wiring connections are readily accessible, and mounting holes and/or slots are predrilled to save installation time and field labor expense.
- Exposed units and/or panels have a baked on powder coat finish.

COILS

- Coils have internally enhanced copper tubing expanded to high efficiency aluminum fins.
- Each coil is factory tested to 450 psig.

DRAIN PANS

- Drain pan is made from heavy gauge galvanized steel with "folded corner joints".
- Drain pan is insulated with a U.L. Listed, closed cell, fire retardant foam insulation to prevent sweating.

BLOWER ASSEMBLIES

- All blower wheels are centrifugal, forward curved, and dynamically balanced for smooth, quiet operation.
- Blower assemblies can be easily removed for service.

MOTORS

- Standard motors are PSC type with internal thermal overload protection. Motors have permanently lubricated sleeve bearings for long life. All motors are resiliently mounted with rubber bushings to assure quiet, vibration-free operation and are easily removed.
- ECM motors have multi-speed connections or a jumper to change speeds. Motors have permanently lubricated sleeve bearings for long life. All motors are resiliently mounted with rubber bushings to assure quiet, vibration-free operation and are easily removed.
- Water coils and pumps shall be NSF/ASNI 169:2016 certified for public health and should contain less than 2% lead. All water coils should have a check valve internal to the pump and have an air purge valve factory-installed.



AMERICAN MADE. FAMILY OWNED.



FIRST CO.
P.O. BOX 270969 - DALLAS, TEXAS 75227
PH. (214) 388-5751 | FAX (214) 388-2255
WWW.FIRSTCO.COM

APRIL 2026