



CDX

Fan Coil



Horizontal Recessed
1 1/2 - 3 Ton Cooling
Up to 51,700 BTUH HW Heat

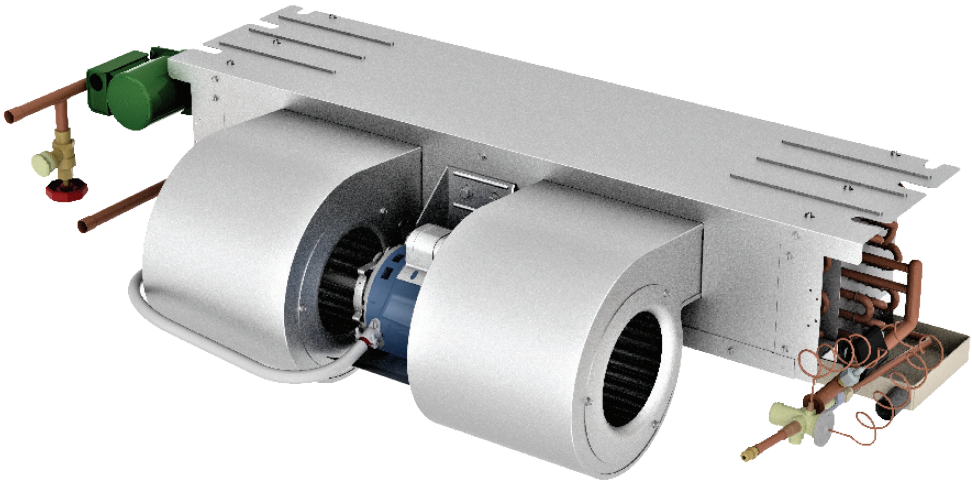

NOMENCLATURE

25 CDX Q X B R -C W/TXV

Unit Size Tonnage

- 18 - 1.5 ton (*ST)
- 19 - 1.5 ton (*HE)
- 20 - 1.5 ton (*ME)
- 24 - 2 ton (*ST)
- 25 - 2 ton (*HE)
- 26 - 2 ton (*ME)
- 30 - 2.5 ton (*ST)
- 31 - 2.5 ton (*HE)
- 32 - 2.5 ton (*ME)
- 36 - 3 ton (*ST)
- 37 - 3 ton (*ME)

Unit Model Series

- CDX - Horizontal fan coil ceiling mount

Pump Option

- Q - with factory installed pump
- HW - with out pump

Motor Option

- No letter - PSC motor
- X - with ECM motor

Control Option

- No letter - standard relay controls
- B - circuit board controls

Enhanced Pump Option

- No letter - standard pump
- R - with enhanced pump for tankless use
- note: This R option includes circuit board controls

Cased Option

- No letter - un-cased unit
- C - cased unit with panel

Metering Device

- No letter - piston type metering
- W/R410 TXV - thermal expansion valve

- * ST - standard coil
- HE - high efficiency coil
- ME - maximum efficiency coil

For rating efficiency visit AHRI.org.

RECOGNIZED COMPONENT



Intertek

NSF/ANSI

169:2016



In keeping with our policy of continuous progress and product improvement, First Co. reserves the right to make changes without notice.

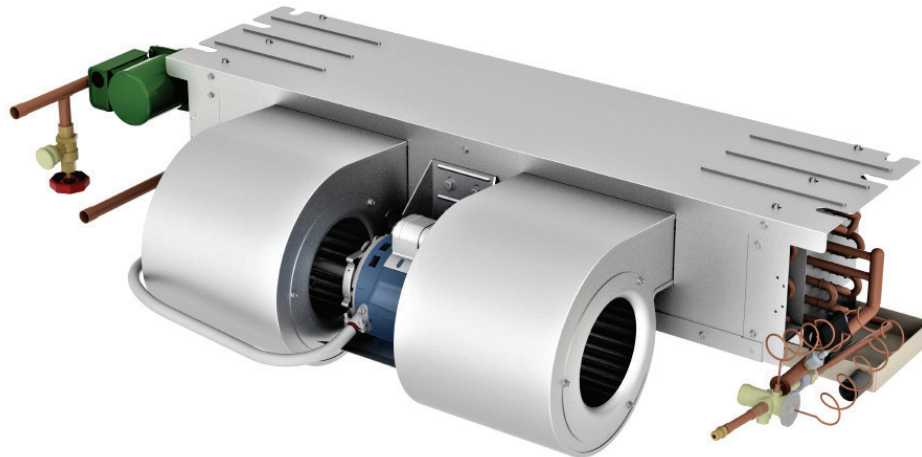

The space-saving CDX Fan Coil is only 10" high (11" with enclosure) thus allowing it to recess in a ceiling. Recessed ceiling fan coils save valuable floor space and eliminate costly "equipment" closets.

All CDX fan coils include a 120/24V transformer and are completely prewired. A sloped drain pan allows positive drainage of condensate.

These fan coils are compatible with any source of hot water that does not exceed 180°F, and is NSF/ANSI certified for use with domestic water.

(1) First Co.'s customer is ultimately responsible for confirming which fan coil models are compatible with selected outdoor unit(s) and which expansion valves (if any) are required. To determine certified indoor/outdoor matches, go to www.ahrirectory.org or www.firstco.com.

STANDARD FEATURES

- Factory installed service switch
- Freeze protector on HW coil
- Freeze protector on DX coil
- Two-speed fan operation
- Drain pan has 3/4" NPT primary and secondary (overflow) fittings
- 120V motor, 24V controls
- Highly efficient copper tube / aluminum fin heating and cooling coils. Cooling coil has a piston-type metering device for factory or field installed R410A TXV's (non-bleed type). Contact factory for correct match with outdoor unit.
- Insulated and coated galvanized steel drain pan is sloped for proper drainage.
- Effective January 2016, cabinet air leakage is no more than 2% when tested in accordance with ASHRAE 193.

OPTIONAL ACCESSORIES

- Attractive off-white return air / access panel with captive screws (panels can be field painted)
- IAQ filter panels
- Fully insulated enclosure with matching ceiling panel allows for ducted return air. Enclosure can be pre-installed.
- Factory or field-installed TXV's (non-bleed type)
- Condensate overflow switch (field installed) (# SS3)

CIRCUIT BOARD FEATURES

WHEN "B" IS ADDED TO MODEL NUMBER

Multi-function micro-processor circuit board with:

- Automatic pump timer (heating mode) - purge mode (60 seconds every 6 hours)
- Blower-on fan delay (heating mode) - preheats HW coil for 45 seconds
- Blower-off fan delay (heating and cooling modes) Blower continues to operate for 15 seconds after thermostat is satisfied for increased efficiency.

PHYSICAL DIMENSIONS

UNCASED VERSION NO PUMP

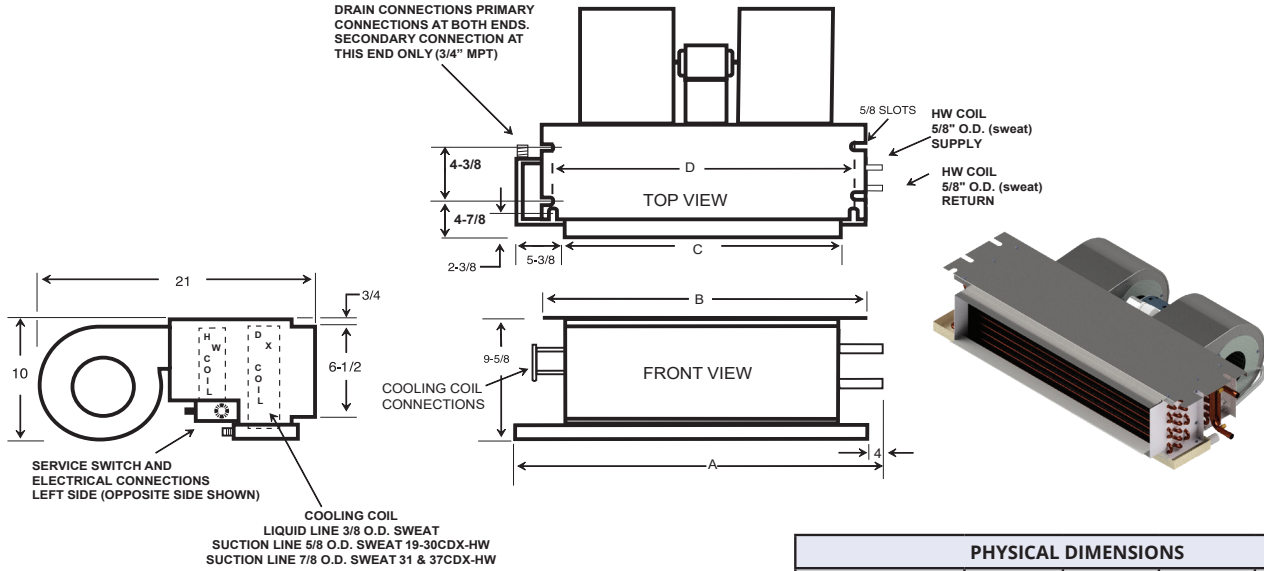

PHYSICAL DIMENSIONS				
UNIT MODEL	A	B	C	D
18/19CDX	38-1/8	37-1/4	30-1/8	34-3/4
20/25CDX	44-1/8	43-1/4	36-1/8	40-3/4
26/31CDX	50-1/8	49-1/4	42-1/8	46-3/4
32/37CDX	57-1/8	56-1/4	49-1/8	53-3/4

UNCASED VERSION WITH PUMP

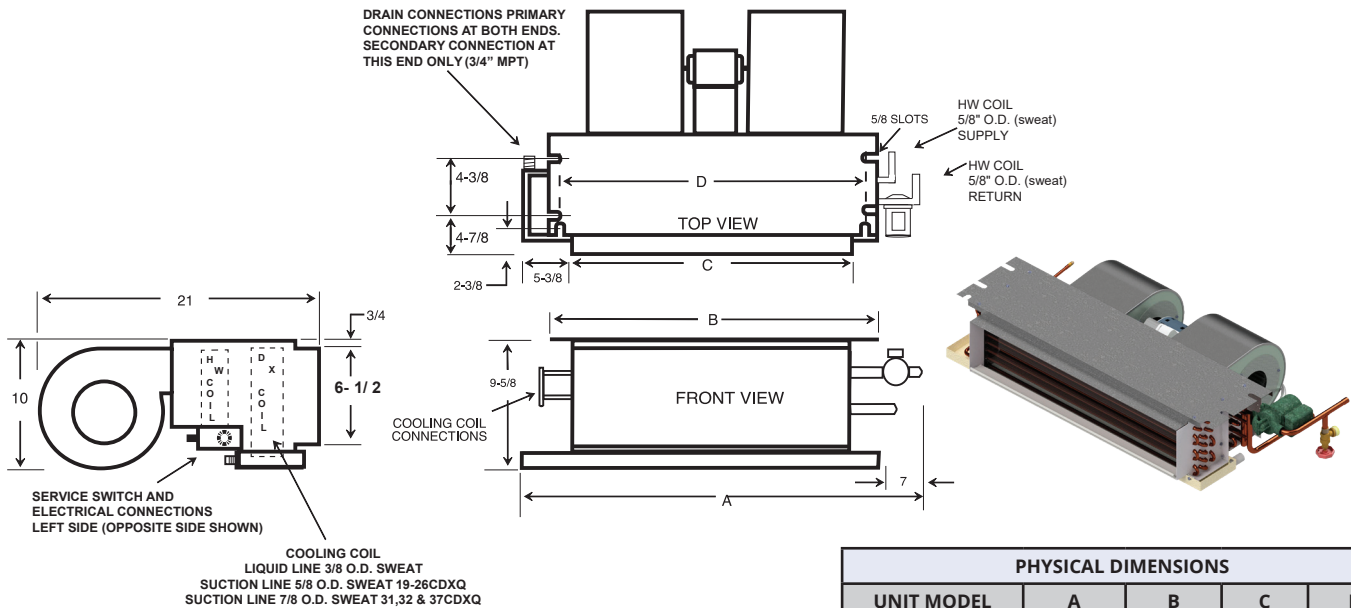

PHYSICAL DIMENSIONS				
UNIT MODEL	A	B	C	D
18/19CDXQ*	45-1/8	37-1/4	30-1/8	34-3/4
20-25CDXQ*	51-1/8	43-1/4	36-1/8	40-3/4
26/31CDXQ*	57-1/8	49-1/4	42-1/8	46-3/4
32/37CDXQ*	64-1/8	56-1/4	49-1/8	53-3/4

CASED VERSION

KNOCKOUT FOR DUCTED RETURN
 Ducted return requires remote filter grille (field supplied) and non-louvered panel.

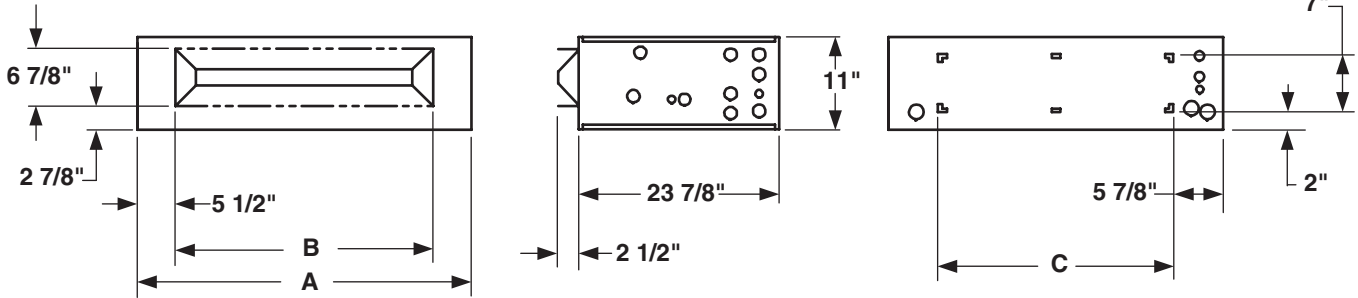

ENCLOSURE DIMENSIONS					PANEL NO. (STD.)	PANEL NO. (IAQ)	DESCRIPTION	CEILING PANEL OPENING		PANEL FRAME DIMS (OUTSIDE)	
FOR MODEL	ENCLOSURE	A	B	C			(2)	W	L	W	L
18/19CDX	9ECDX01 (1)	45-3/4	30-7/8	34	966	966-M8	LOUVERED	24-1/2	46	27-1/2	49
					966-1	NA	NON-LOUVERED	24-1/2	46	27-1/2	49
20/25CDX	9ECDX02 (1)	51-3/4	36-7/8	40	967	967-M8	LOUVERED	24-1/2	52-1/2	27-1/2	55-1/2
					967-1	NA	NON-LOUVERED	24-1/2	52-1/2	27-1/2	55-1/2
26/31CDX	9ECDX03 (1)	58-1/2	42-7/8	46-3/4	967-6	967-6-M8	LOUVERED	24-1/2	60	27-1/2	63
					967-7	NA	NON-LOUVERED	24-1/2	60	27-1/2	63
32/37CDX	9ECDX04 (1)	66-1/2	49-7/8	54-3/4	967-8	967-8-M8	LOUVERED	24-1/2	67	27-1/2	70
					967-5	NA	NON-LOUVERED	24-1/2	67	27-1/2	70

CEILING ACCESS PANELS - FOR CDX SERIES

CEILING ACCESS PANELS							
FOR MODEL	PANELNO. (STD.)	PANELNO. (IAQ)	DESCRIPTION	CEILING PANEL OPENING		PANEL FRAME DIMS (OUTSIDE)	
18/19CDX	966	966-M8	LOUVERED	24-1/2	46	27-1/2	49
	966-1	NA	NON-LOUVERED	24-1/2	46	27-1/2	49
20/25CDX	967	967-M8	LOUVERED	24-1/2	52-1/2	27-1/2	55-1/2
	967-1	NA	NON-LOUVERED	24-1/2	52-1/2	27-1/2	55-1/2
26/31CDX	967-6	967-6-M8	LOUVERED	24-1/2	60	27-1/2	63
	967-7	NA	NON-LOUVERED	24-1/2	60	27-1/2	63
32/37CDX	967-8	967-8-MA	LOUVERED	24-1/2	67	27-1/2	70
	967-5	NA	NON-LOUVERED	24-1/2	67	27-1/2	70

STANDARD PANELS



SOLID

965-1, 966-1, 967-1, 967-7



LOUVERED

965, 966, 967, 967-6
 (Louvers may differ from picture).
 Louvered panels accept 20x20x1" filter (field supplied).

IAQ PANELS



966-M8, 967-M8 (accepts 2-20x20x1 filter)
 # 967-6-M8 (accepts 2-20x25x1 filter)
 # 967-8-M8 (accepts 2-20x30x1 filter)
 GlasFloss® Industries Series HV filter or equivalent is recommended.

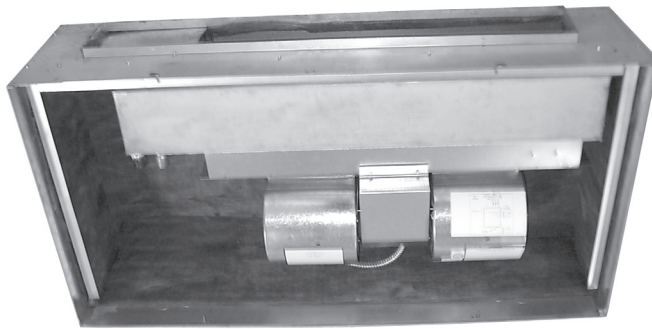

Picture shown is a "-C" model with installed **CDX** (available from the factory as a complete unit).

ENCLOSURE INSTALLATION SUPPORT FRAMING

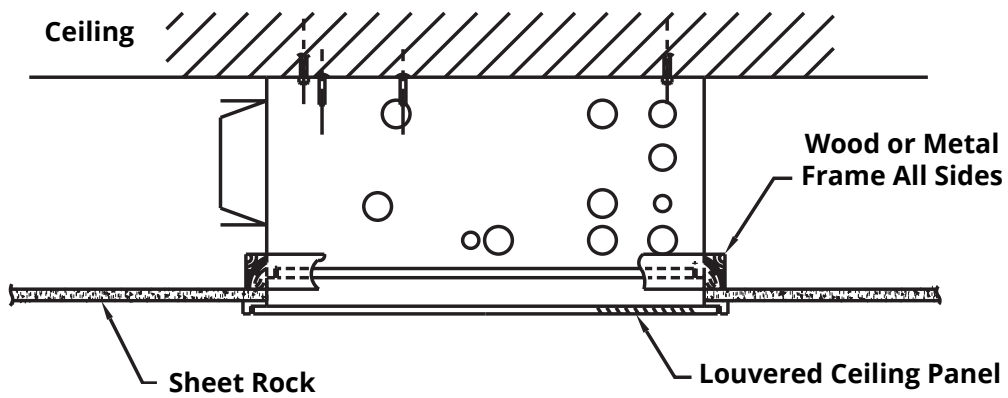

ENCLOSURE CONNECTION LOCATIONS

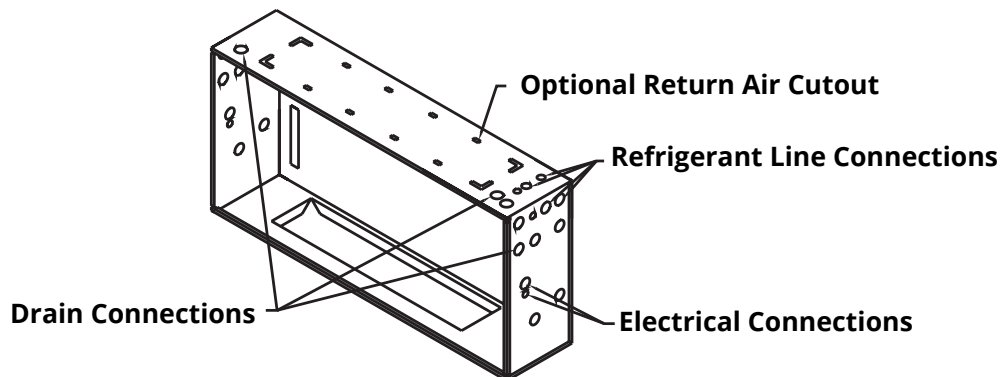

CDX Series - Without Pump

1-1/2 THROUGH 3 TONS

PERFORMANCE DATA

PERFORMANCE DATA CDX-HW								
UNIT MODEL	NOMINAL COOLING BTUH	PRESS. DROP (FT. WTR)	BTUH (1000) AT ENTERING WATER TEMPERATURE Delta-T 20°F & GPM					
			120°F	GPM	140°F	GPM	180°F	GPM
			18/19CDX-HW	18,000	0.7	10.3	1.0	14.4
2.0	12.0	1.2			16.8	1.7	26.4	2.6
3.3	12.9	1.3			18.0	1.8	28.3	2.8
20CDX-HW	18,000	0.8	10.9	1.1	15.3	1.5	24.0	2.4
		2.1	12.9	1.3	18.0	1.8	28.3	2.8
		4.1	13.7	1.4	19.2	1.9	30.2	3.0
25CDX-HW	24,000	2.1	14.7	1.5	20.6	2.1	32.4	3.2
		4.1	15.9	1.6	22.2	2.2	34.9	3.5
		6.6	16.5	1.7	23.1	2.3	36.3	3.6
26CDX-HW	24,000	2.2	15.7	1.6	22.0	2.2	34.6	3.5
		4.3	17.0	1.7	23.8	2.4	37.4	3.7
		6.8	17.6	1.8	24.7	2.5	38.8	3.9
30/31CDX-HW	30,000	2.2	17.3	1.7	24.2	2.4	38.0	3.8
		4.3	18.8	1.9	26.3	2.6	41.3	4.1
		6.8	19.6	2.0	27.5	2.8	43.2	4.3
32CDX-HW	30,000	2.8	18.4	1.8	25.8	2.6	40.5	4.1
		5.4	20.1	2.0	28.2	2.8	44.3	4.4
		8.5	21.1	2.1	29.5	3.0	46.4	4.6
37CDX-HW	36,000	2.8	19.7	2.0	27.6	2.8	43.4	4.3
		5.4	21.7	2.2	30.4	3.0	47.8	4.8
		8.5	22.8	2.3	31.9	3.2	50.1	5.0

PERFORMANCE DATA CDXX-HW								
UNIT MODEL	NOMINAL COOLING BTUH	PRESS. DROP (FT. WTR)	BTUH (1000) AT ENTERING WATER TEMPERATURE Delta-T-20°F & GPM					
			120°F	GPM	140°F	GPM	180°F	GPM
			18/19CDXX-HW	18,000	0.7	10.3	1.0	14.4
2.0	12.0	1.2			16.8	1.7	26.4	2.6
3.3	12.9	1.3			18.0	1.8	28.3	2.8
20CDXX-HW	18,000	0.8	10.9	1.1	15.3	1.5	24.0	2.4
		2.1	12.9	1.3	18.0	1.8	28.3	2.8
		4.1	13.7	1.4	19.2	1.9	30.2	3.0
25CDXX-HW	24,000	2.1	14.7	1.5	20.6	2.1	32.4	3.2
		4.1	15.9	1.6	22.2	2.2	34.9	3.5
		6.6	16.5	1.7	23.1	2.3	36.3	3.6
26CDXX-HW	24,000	2.2	15.7	1.7	22.0	2.4	34.6	3.8
		4.3	17.0	1.9	23.8	2.6	37.4	4.1
		6.8	17.6	2.0	24.7	2.8	38.8	4.3
31CDXX-HW	30,000	2.2	17.3	1.7	24.2	2.4	38.0	3.8
		4.3	18.8	1.9	26.3	2.6	41.3	4.1
		6.8	19.6	2.0	27.5	2.8	43.2	4.3
32CDXX-HW	30,000	2.8	18.4	1.8	25.8	2.6	40.5	4.1
		5.4	20.1	2.0	28.2	2.8	44.3	4.4
		8.5	21.1	2.1	29.5	3.0	46.4	4.6
37CDXX-HW	36,000	2.8	19.7	2.0	27.6	2.8	43.4	4.3
		5.4	21.7	2.2	30.4	3.0	47.8	4.8
		8.5	22.8	2.3	31.9	3.2	50.1	5.0

NOTES:

1. Heat BTUH is at 70° F EAT.
2. Based on 20°F Delta - T. Velocity not to exceed 4ft./sec.
3. 120 degree and 180 degree data is supplied for boiler applications.
4. Heating BTUH output will not exceed output of water heater.
5. Approved for installation with 0" clearance to combustible material.
6. Use capacities when First Co. "Flow Control Module" is used (# 940-3CV).
7. Freeze protection standard on hot water and DX coils.

CDX Series - With Pump

1-1/2 THROUGH 3 TONS

PERFORMANCE DATA

PERFORMANCE DATA CDXQ										
UNIT MODEL	NOMINAL COOLING BTUH	PRESS. DROP (FT. WTR)	BTUH (1000) AT ENTERING WATER TEMPERATURE Delta-T 20°F & GPM							
			120°F	GPM	130°F	GPM	140°F	GPM	180°F	GPM
18/19CDXQ*	18,000	3.3	12.9	1.3	15.4	1.5	18.0	1.8	28.3	2.8
20CDXQ*	18,000	4.1	13.7	1.4	16.5	1.7	19.2	1.9	30.2	3.0
24/25CDXQ*	24,000	4.1	15.9	1.6	19.0	1.9	22.2	2.2	34.9	3.5
26CDXQ*	24,000	4.3	17.0	1.7	20.4	2.0	23.8	2.4	37.4	3.7
30/31CDXQ*	30,000	4.3	18.8	1.9	22.5	2.3	26.3	2.6	41.3	4.1
32CDXQ*	30,000	5.4	20.1	2.0	24.2	2.4	28.2	2.8	44.3	4.4
37CDXQ*	36,000	5.4	21.7	2.2	26.1	2.6	30.4	3.0	47.8	4.8

PERFORMANCE DATA CDXQX										
UNIT MODEL	NOMINAL COOLING BTUH	PRESS. DROP (FT. WTR)	BTUH (1000) AT ENTERING WATER TEMPERATURE Delta-T 20°F & GPM							
			120°F	GPM	130°F	GPM	140°F	GPM	180°F	GPM
18/19CDXQ*X	18,000	3.3	12.9	1.3	15.4	1.5	18.0	1.8	28.3	2.8
20CDXQ*X	18,000	4.1	13.7	1.4	16.5	1.7	19.2	1.9	30.2	3.0
25CDXQ*X	24,000	4.1	15.9	1.6	19.0	1.9	22.2	2.2	34.9	3.5
26CDXQ*X	24,000	4.3	17.0	1.7	20.4	2.0	23.8	2.4	37.4	3.7
31CDXQ*X	30,000	4.3	18.8	1.9	22.5	2.3	26.3	2.6	41.3	4.1
32CDXQ*X	30,000	5.4	20.1	2.0	24.2	2.4	28.2	2.8	44.3	4.4
37CDXQ*X	36,000	5.4	21.7	2.2	26.1	2.6	30.4	3.0	47.8	4.8

NOTES:

1. Heat BTUH is at 70° F EAT.
2. 120° F and 180° F data is supplied for boiler applications.
3. Heating BTUH output will not exceed output of water heater.
4. Approved for installation with 0" clearance to combustible material.
5. Freeze protection on hot water and DX coils.
6. Based on 20° Delta-T, Velocity not to exceed 4ft./sec.

CDX Series

1-1/2 THROUGH 3 TONS

BLOWER DATA

BLOWER DATA WITH PSC MOTOR													
UNIT MODEL	MOTOR (1)		MOTOR HP (120V)	MIN. CKT. AMPACITY (120V)	MAX. CKT. PROTECTION	CFM vs. EXTERNAL STATIC PRESSURE (3)							
	RPM	AMPS				0.05	0.10	0.15	0.20	0.25	0.30	0.35	0.40
18/19/20CDX	1550	2.3	1/5	3	15	710	680	650	620	590	560	530	500
24/25/26CDX	1550	3.6	1/4	5	15	880	840	800	760	720	680	640	600
30/31CDX	1550	4.6	1/5	6	15	1100	1060	1020	980	930	880	830	780
32CDX	1550	4.6	1/5	6	15	1160	1130	1095	1060	1025	990	950	910
37CDX	1550	4.6	1/5	6	15	1310	1260	1210	1160	1110	1060	1000	940

NOTES:

- Units should not be applied to a system with less than 350 CFM/Ton airflow.
- Motors are 120V and operate on high speed for cool and low speed for heating.
- CFM vs. static at high motor speed.
- Add .05 static when enclosure and/or ceiling panel is used.
- 31, 32 and 37 CDX-HW have two motors and four blowers.

BLOWER DATA WITH ECM Motor												
MODEL	MOTOR HP	SPEED TAP	TAP COLOR	BHP	MOTOR AMPS	CFM vs. EXTERNAL STATIC PRESSURE						
						0.10	0.15	0.20	0.25	0.30	0.35	0.40
18/19/20CDX*X	1/2	OPTIONAL HIGH	GREEN	0.22	2.8	760	745	730	715	700	685	670
		STD. HIGH	ORANGE	0.17	2.1	670	650	630	615	600	588	570
		STD. LOW	YELLOW	0.14	1.6	570	555	540	520	500	480	---
25/26CDX*X	1/2	OPTIONAL HIGH	WHITE	0.30	3.8	980	960	940	920	900	875	850
		STD. HIGH	GREEN	0.25	3.0	890	870	850	830	810	790	770
		STD. LOW	ORANGE	0.21	2.5	800	775	750	725	700	675	---
		OPTIONAL LOW	YELLOW	0.18	2.0	730	710	690	670	650	630	---
30/31CDX*X	1/2	OPTIONAL HIGH	WHITE	0.40	4.7	1160	1145	1130	1115	1100	1080	1060
		STD. HIGH	GREEN	0.33	3.8	1060	1040	1020	1105	990	975	960
		STD. LOW	ORANGE	0.28	3.2	970	955	940	920	900	880	860
		OPTIONAL LOW	YELLOW	0.23	2.6	870	850	830	810	790	770	---
32CDX*X	1/2	OPTIONAL HIGH	WHITE	0.39	4.8	1220	1200	1180	1155	1125	1095	1065
		STD. HIGH	GREEN	0.27	3.2	1030	1005	985	960	940	920	900
		STD. LOW	ORANGE	0.22	2.5	905	885	860	840	820	800	---
		OPTIONAL LOW	YELLOW	0.16	1.8	725	705	685	670	650	630	---
37CDX*X	1/2 (2)	OPTIONAL HIGH	WHITE	0.45	5.6	1380	1360	1340	1320	1300	1280	1260
		STD. HIGH	GREEN	0.38	4.7	1290	1270	1250	1225	1200	1175	1150
		STD. LOW	ORANGE	0.31	3.7	1130	1105	1080	1055	1030	1010	---
		OPTIONAL LOW	YELLOW	0.26	3.0	1000	975	950	920	890	875	---

NOTES:

- Units should not be applied to a system with less than 350 CFM/Ton airflow.
- Shaded speeds are factory settings.
- Add .05 static when enclosure and/or ceiling panel is used.
- 37 CDXX has two motors and four blowers.

CDX Series - Without Pump

1-1/2 THROUGH 3 TONS

ELECTRICAL DATA

ELECTRICAL DATA WITH PSC MOTOR					
UNIT MODEL	MOTOR (1)		MOTOR HP (120V)	MIN. CKT. AMPACITY (120V)	MAX. CKT. PROTECTION
	RPM	AMPS			
18/19/20CDX-HW	1550	2.3	1/5	3	15
25/26CDX-HW	1550	3.6	1/4	5	15
30/31CDX-HW	1550	4.6	1/5	6	15
32CDX-HW	1550	4.6	1/5	6	15
37CDX-HW	1550	4.6	1/5	6	15

ELECTRICAL DATA WITH ECM MOTOR				
UNIT MODEL	MOTOR HP	AMPS	MIN. CIR AMPACITY	MAX CIR PROTECTION
		MOTOR		
18/19/20CDXX-HW	1/2	7.0	9	15
25/26CDXX-HW	1/2	7.0	9	15
31CDXX-HW	1/2	7.0	9	15
32CDXX-HW	1/2	7.0	9	15
37CDXX-HW	1/2 (2)	7.0	16	20

CDX Series - With Pump

1-1/2 THROUGH 3 TONS

ELECTRICAL DATA

ELECTRICAL DATA WITH PSC MOTOR STANDARD PUMP					
UNIT MODEL	MOTOR HP (120V)	AMPS (120V)		MIN. CIR AMPACITY	MAX CIR PROTECTION
		MOTOR	PUMP		
18/19/20CDXQ*	1/5	2.3	0.75	4	15
24CDXQ*	1/5	3.0	0.75	5	15
25/26CDXQ*	1/4	3.6	0.75	6	15
30/31CDXQ*	1/5	4.6	0.75	7	15
32CDXQ*	1/5	4.6	0.75	7	15
37CDXQ*	1/5	4.6	0.75	7	15

ELECTRICAL DATA WITH PSC MOTOR AND UPGRADED PUMP					
UNIT MODEL	MOTOR HP (120V)	AMPS (120V)		MIN. CIR AMPACITY	MAX CIR PROTECTION
		MOTOR	PUMP		
18/19/20CDXQ*	1/5	2.3	0.84	4	15
25/26CDXQ*	1/4	3.6	0.84	6	15
30/31CDXQ*	1/5 (2)	4.6	0.84	7	15
32CDXQ*	1/5 (2)	4.6	0.84	7	15
37CDXQ*	1/5 (2)	4.6	0.84	7	15

ELECTRICAL DATA WITH ECM MOTOR AND STANDARD PUMP					
UNIT MODEL	MOTOR HP	AMPS		MIN. CIR AMPACITY	MAX CIR PROTECTION
		MOTOR	PUMP		
18/19/20CDXQ*X	1/2	7.0	0.75	10	15
25/26CDXQ*X	1/2	7.0	0.75	10	15
31CDXQ*X	1/2	7.0	0.75	10	15
32CDXQ*X	1/2	7.0	0.75	10	15
37CDXQ*X	1/2 (2)	7.0	0.75	17	20

ELECTRICAL DATA WITH ECM MOTOR AND UPGRADED PUMP					
UNIT MODEL	MOTOR HP	AMPS		MIN. CIR AMPACITY	MAX CIR PROTECTION
		MOTOR	PUMP		
18/19/20CDXQ*X	1/2	7.0	.84	10	15
25/26CDXQ*X	1/2	7.0	.84	10	15
31CDXQ*X	1/2	7.0	.84	10	15
32CDXQ*X	1/2	7.0	.84	10	15
37CDXQ*X	1/2 (2)	7.0	.84	17	20

GUIDE SPECIFICATIONS

UNIT

All fan coils are manufactured with 20 to 22 gauge galvanized steel to resist corrosion.

All units are approved for installation with "0" clearance to combustible material.

Piping, drain, and wiring connections are readily accessible, and mounting holes and/or slots are predrilled to save installation time and field labor expense.

Exposed units and/or panels have a baked on powder coat finish.

COILS

Coils have 3/8" O.D. copper tubing expanded to high efficiency aluminum fins.

Each coil is factory tested to 450 psig.

DRAIN PANS

Drain pan is made from heavy gauge galvanized steel with "folded corner joints".

Drain pan is insulated with a U.L. Listed, closed cell, fire retardant foam insulation to prevent sweating.

BLOWER ASSEMBLIES

All blower wheels are centrifugal, forward curved, and dynamically balanced for smooth, quiet operation.

Blower assemblies can be easily removed for service.

MOTORS

Standard motors are PSC type with internal thermal overload protection. Motors have permanently lubricated sleeve bearings for long life. All motors are resiliently mounted with rubber bushings to assure quiet, vibration-free operation and are easily removed.

ECM motors should have multi-speed connections or speed jumper changes. Motors have permanently lubricated sleeve bearings for long life. All motors are resiliently mounted with rubber bushings to assure quiet, vibration-free operation and are easily removed.

Water coils and pumps shall be NSF/ASNI 169:2016 certified for public health and should contain less than 2% lead.

All water coils should have a check valve internal to the pump and have an air purge valve factory-installed.



FIRST CO. P.O. BOX 270969 - DALLAS, TEXAS 75227
PH. (214) 388-5751 | FAX (214) 388-2255
WWW.FIRSTCO.COM
JULY 2024