

*First Co.*

# CDX SERIES

CDXW/X • CDXQ/X • CDXR/X

Ceiling Fan Coils



Horizontal Recessed

HW Coils, Standard Pump, Hi Flow Pump

Compatible with R32 and R454B

Compatible with R410A for Servicing Existing Equipment Only

1.5 thru 3 Tons Cooling

Up to 51,700 BTUH HW Heat

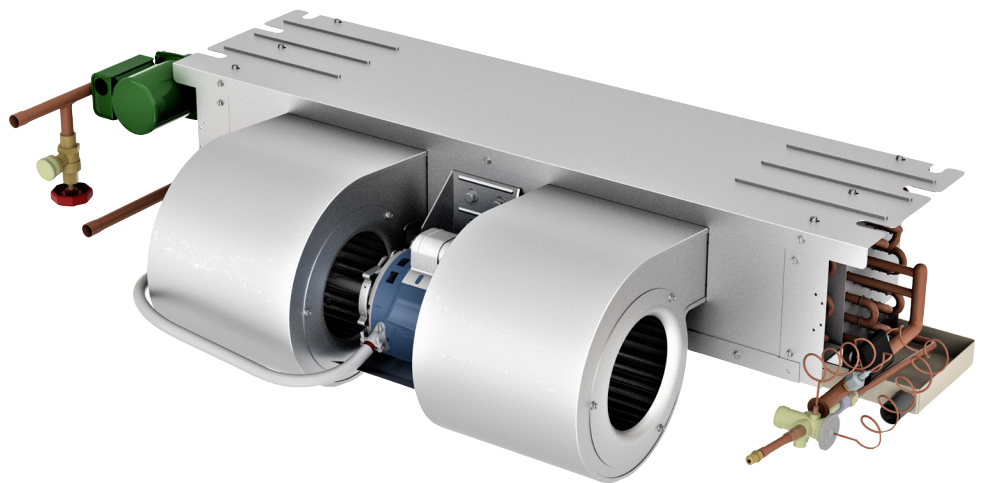

**AHRI CERTIFIED**<sup>®</sup>  
www.ahridirectory.org

Unitary Small AC  
AHRI Standard 210/240  
Certification applies only when the complete system  
is listed with AHRI.

---

# TABLE OF CONTENTS

NOMENCLATURE .....3

SERIES FEATURES .....4

ACCESSORIES .....6

DIMENSIONS .....8

BLOWER DATA ..... 10

CDXW DATA ..... 12

CDXWX DATA ..... 13

CDXQ DATA ..... 14

CDXQX DATA ..... 16

CDXR DATA ..... 17

CDXRX DATA ..... 18

GUIDE SPECIFICATIONS ..... 19

First Co.'s customer is ultimately responsible for confirming which fan coil models are compatible with selected outdoor unit(s) and which expansion valves (if any) are required. To determine certified indoor/outdoor combinations, go to [www.firstco.com](http://www.firstco.com) or contact the factory.

In keeping with its policy of continuous progress and product improvement, First Co. reserves the right to make changes without notice.

# NOMENCLATURE

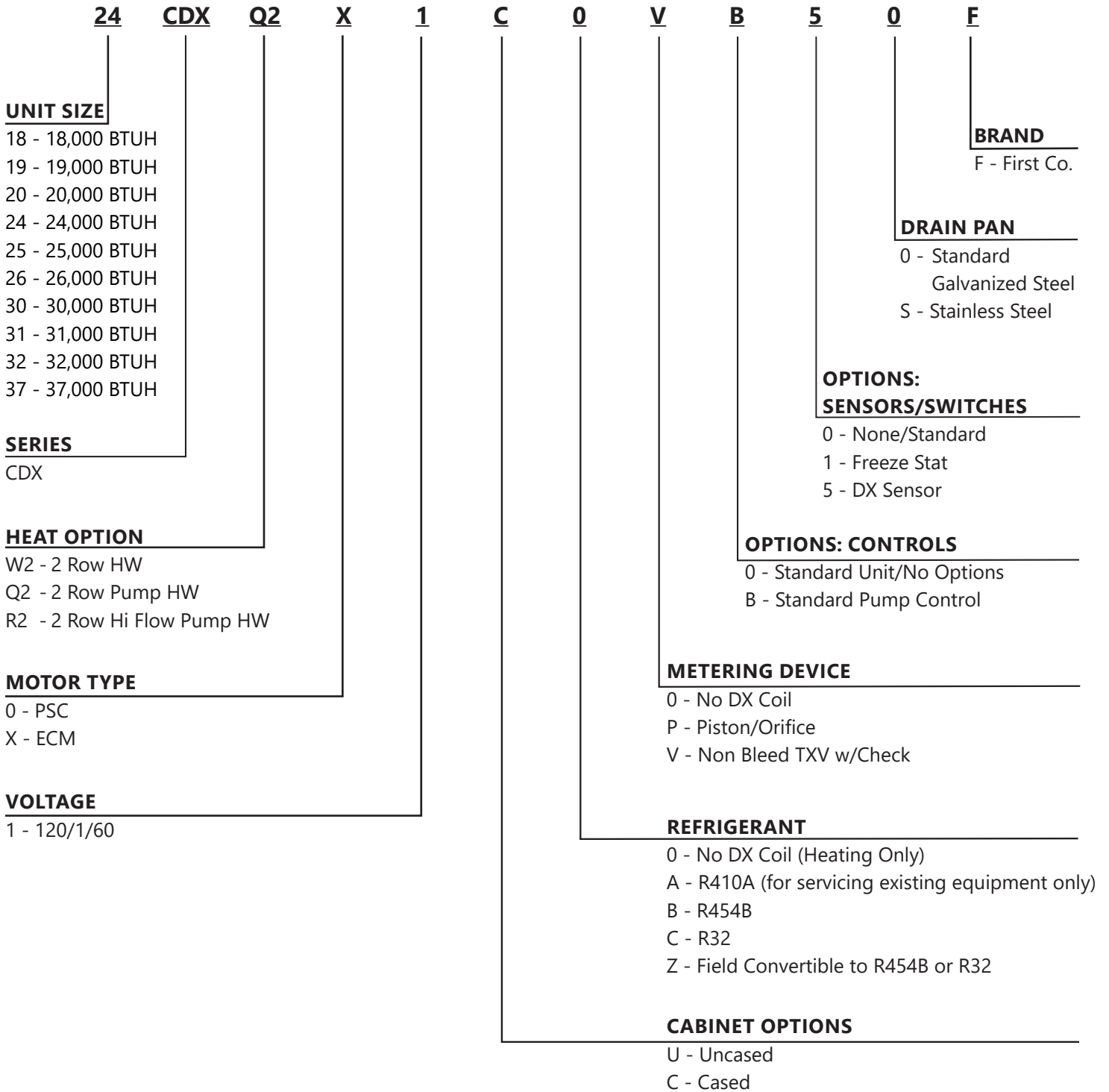

---

# CDX SERIES

## CEILING FAN COILS

The space-saving CDX fan coil is only 10" high (11" with enclosure) thus allowing it to recess in a ceiling. Recessed ceiling fan coils save valuable floor space and eliminate costly "equipment" closets.

All CDX fan coils include a 120/24V transformer and are completely prewired. A sloped drain pan allows positive drainage of condensate.

These fan coils are compatible with any source of hot water that does not exceed 180°F, and is NSF/ANSI certified for use with domestic water.

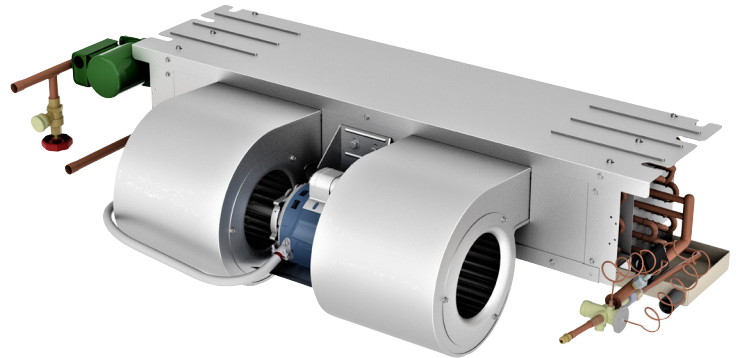

## STANDARD FEATURES

- Factory installed service switch
- Freeze protector on HW coil
- Freeze protector on DX coil
- Two-speed fan operation
- Drain pan has 3/4" NPT primary and secondary (overflow) fittings
- 120V motor, 24V controls
- Highly efficient copper tube/aluminum fin heating and cooling coils. Cooling coils are compatible with R454B, R32 using non-bleed TXVs or piston type metering devices. Units ordered for R454B and R32 (Options B and C) are factory configured with TXV or piston and factory mounted refrigerant sensor. Field convertible units (Option Z) are available with TXV and Refrigerant Sensor Kit.
- Insulated and coated galvanized steel drain pan is sloped for proper drainage.
- Effective January 2016, cabinet air leakage is no more than 2% when tested in accordance with ASHRAE 193.

## OPTIONAL ACCESSORIES

- Attractive off-white return air / access panel with captive screws (panels can be field painted)
- IAQ filter panels
- Fully insulated enclosure with matching ceiling panel allows for ducted return air. Enclosure can be pre-installed.
- Condensate overflow switch (field installed) (# SS3)
- Factory or field installed R454B or R32 TXV (non-bleed type). R454B and R32 units will require a Refrigerant Sensor.

# CDX SERIES

## CEILING FAN COILS

### IMPORTANT NOTE

When these units are used with A2L refrigerants they must be fitted with a REFRIGERANT SENSOR and if using a TXV then the TXV must be compatible with the A2L refrigerant that is used. Failure to use a REFRIGERANT SENSOR may result in unit damage, property damage and/or death. Warranty will be void.

EXPANSION VALVE/REFRIGERANT SENSOR KITS (HEAT PUMP OR COOLING ONLY)		
PART NUMBER	TYPE	SENSOR
9EVR410-1	R410A	FOR SERVICING EXISTING EQUIPMENT ONLY
9EVR454B-1	R454B	CE100
9EVR32-1	R32	CE100
9EVR454B-1A	R454B	NO SENSOR
9EVR32-1A	R32	NO SENSOR
9EVR42L-1	R454B/R32	CE100

#### NOTES:

1. Above expansion valve kits are approved for both cooling only (non heat pump) or heat pumps applications.
2. Valves are non-bleed type. Field added. Hard start kit may be required.
3. Valves have screw-on connections.
4. Field installed for field convertible (Z) option.

## CONTROL FEATURES

### WHEN "B" IS SELECTED FOR STANDARD PUMP CONTROL

#### MULTI-FUNCTION MICRO-PROCESSOR CIRCUIT BOARD WITH:

- Automatic pump timer (heating mode) - purge mode (60 seconds every 6 hours)
- Blower-on fan delay (heating mode) - preheats HW coil for 45 seconds
- Blower-off fan delay (heating and cooling modes) Blower continues to operate for 15 seconds after thermostat is satisfied for increased efficiency.

**CEILING ACCESS PANELS**

CEILING ACCESS PANELS							
FOR MODEL	PANEL NO. (STD.)	PANEL NO. (IAQ)	DESCRIPTION	CEILING PANEL OPENING		PANEL FRAME DIMS (OUTSIDE)	
18/19CDX	966	966-M8	LOUVERED	24-1/2	46	27-1/2	49
	966-1	NA	NON-LOUVERED	24-1/2	46	27-1/2	49
20/25CDX	967	967-M8	LOUVERED	24-1/2	52-1/2	27-1/2	55-1/2
	967-1	NA	NON-LOUVERED	24-1/2	52-1/2	27-1/2	55-1/2
26/31CDX	967-6	967-6-M8	LOUVERED	24-1/2	60	27-1/2	63
	967-7	NA	NON-LOUVERED	24-1/2	60	27-1/2	63
32/37CDX	967-8	967-8-MA	LOUVERED	24-1/2	67	27-1/2	70
	967-5	NA	NON-LOUVERED	24-1/2	67	27-1/2	70



**SOLID**  
# 965-1, 966-1, 967-1, 967-7

**LOUVERED**  
# 965, 966, 967, 967-6  
*(Louvers may differ from picture).  
Louvered panels accept 20x20x1" filter  
(field supplied).*

**# 966-M8, 967-M8**  
*(accepts 2-20x20x1 filter)*  
**# 967-6-M8**  
*(accepts 2-20x25x1 filter)*  
**# 967-8-M8**  
*(accepts 2-20x30x1 filter)  
GlasFloss® Industries Series HV filter or  
equivalent is recommended.*

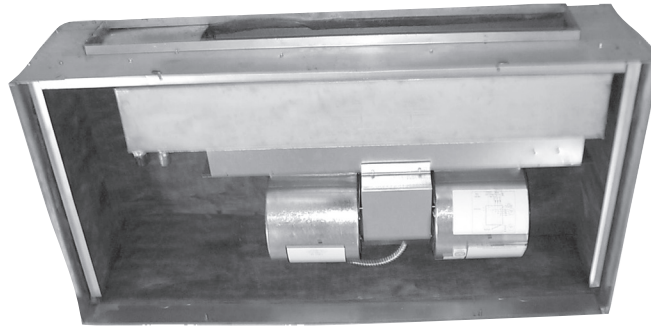

Picture shown is a CDX-C model (available from the factory as a complete unit).

## ENCLOSURE INSTALLATION SUPPORT FRAMING

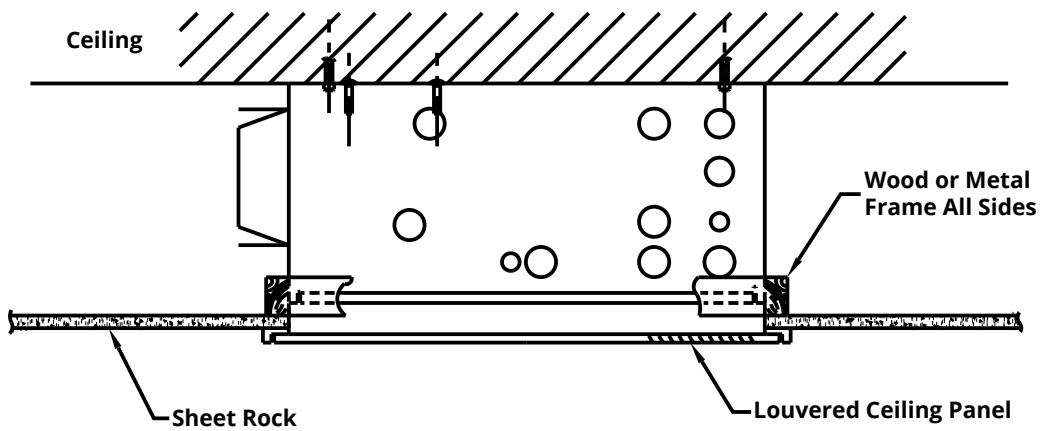

## ENCLOSURE CONNECTION LOCATIONS

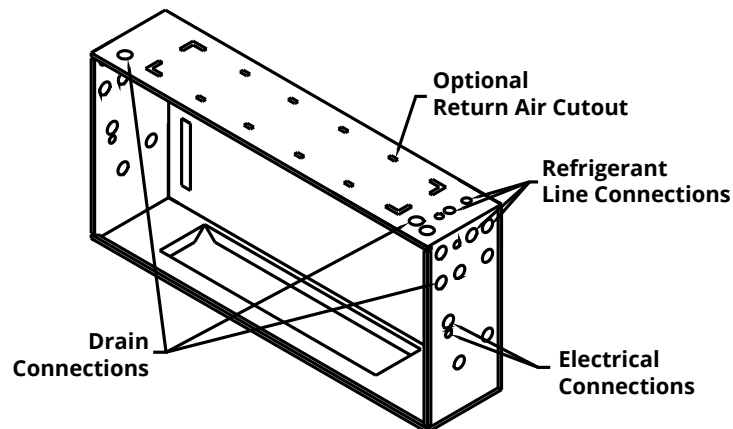

## UNCASED VERSION

PHYSICAL DIMENSIONS				
UNIT MODEL	A	B	C	D
18/19CDX	38-1/8	37-1/4	30-1/8	34-3/4
20/25CDX	44-1/8	43-1/4	36-1/8	40-3/4
26/31CDX	50-1/8	49-1/4	42-1/8	46-3/4
32/37CDX	57-1/8	56-1/4	49-1/8	53-3/4

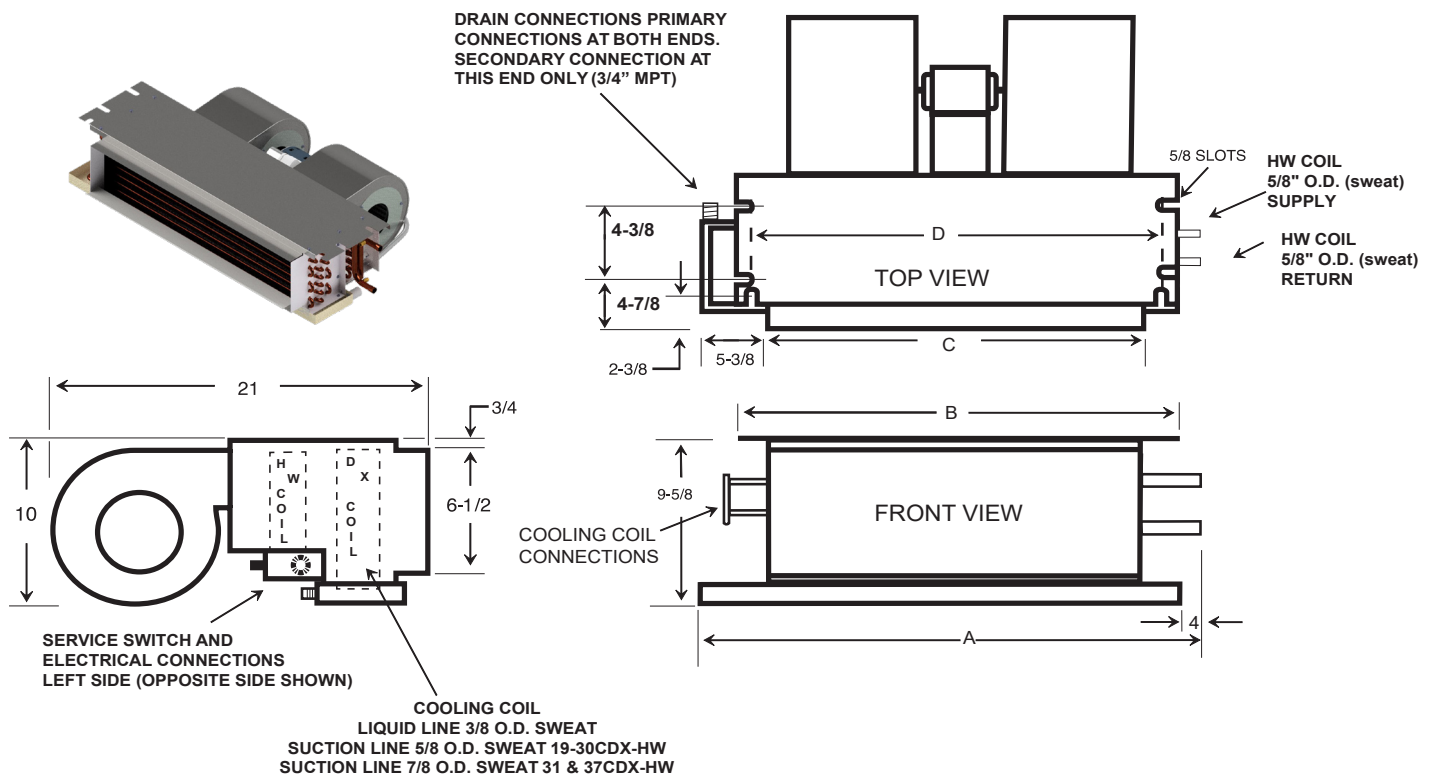



## CASED VERSION

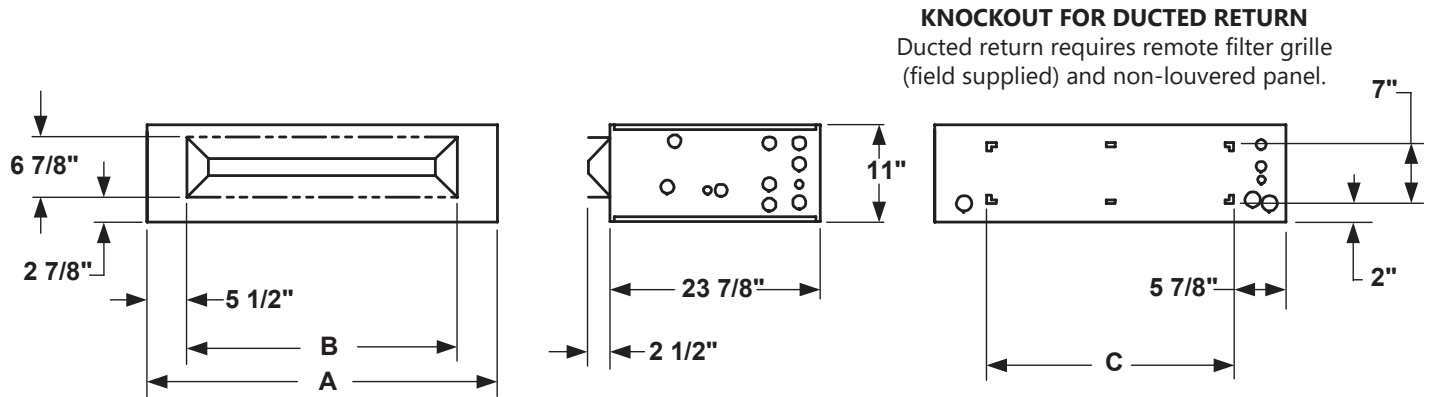

ENCLOSURE DIMENSIONS					PANEL NO. (STD.)	PANEL NO. (IAQ)	DESCRIPTION	CEILING PANEL OPENING		PANEL FRAME DIMS (OUTSIDE)	
FOR MODEL	ENCLOSURE	A	B	C				W	L	W	L
18/19CDX	9ECDX01 (1)	45-3/4	30-7/8	34	966	966-M8	LOUVERED	24-1/2	46	27-1/2	49
					966-1	NA	NON LOUVERED	24-1/2	46	27-1/2	49
20/25CDX	9ECDX02 (1)	51-3/4	36-7/8	40	967	967-M8	LOUVERED	24-1/2	52-1/2	27-1/2	55-1/2
					967-1	NA	NON LOUVERED	24-1/2	52-1/2	27-1/2	55-1/2
26/31CDX	9ECDX03 (1)	58-1/2	42-7/8	46-3/4	967-6	967-6-M8	LOUVERED	24-1/2	60	27-1/2	63
					967-7	NA	NON LOUVERED	24-1/2	60	27-1/2	63
32/37CDX	9ECDX04 (1)	66-1/2	49-7/8	54-3/4	967-8	967-8-M8	LOUVERED	24-1/2	67	27-1/2	70
					967-5	NA	NON LOUVERED	24-1/2	67	27-1/2	70

**CDX SERIES – WITH PSC MOTOR**

<b>BLOWER DATA - ALL CDX MODELS WITH PSC MOTOR</b>													
<b>UNIT MODEL</b>	<b>MOTOR (1)</b>		<b>MOTOR HP (120V)</b>	<b>MIN. CKT. AMPACITY (120V)</b>	<b>MAX. CKT. PROTECTION</b>	<b>CFM vs. EXTERNAL STATIC PRESSURE (3)</b>							
	<b>RPM</b>	<b>AMPS</b>				<b>0.05</b>	<b>0.10</b>	<b>0.15</b>	<b>0.20</b>	<b>0.25</b>	<b>0.30</b>	<b>0.35</b>	<b>0.40</b>
<b>18/19/20CDX</b>	1550	2.3	1/5	3	15	710	680	650	620	590	560	530	500
<b>24/25/26CDX</b>	1550	3.6	1/4	5	15	880	840	800	760	720	680	640	600
<b>30/31CDX</b>	1550	4.6	1/5	6	15	1100	1060	1020	980	930	880	830	780
<b>32CDX</b>	1550	4.6	1/5	6	15	1160	1130	1095	1060	1025	990	950	910
<b>37CDX</b>	1550	4.6	1/5	6	15	1310	1260	1210	1160	1110	1060	1000	940

**NOTES:**

1. Units should not be applied to a system with less than 350 CFM/Ton airflow.
2. Motors are 120V and operate on high speed for cool and low speed for heating.
3. CFM vs. static at high motor speed.
4. Add .05 static when enclosure and/or ceiling panel is used.
5. 31, 32 and 37 CDXW have two motors and four blowers.

## CDX SERIES – WITH ECM MOTOR

BLOWER DATA - ALL CDX MODELS WITH ECM MOTOR												
MODEL	MOTOR HP	SPEED TAP	TAP COLOR	BHP	MOTOR AMPS	CFM vs. EXTERNAL STATIC PRESSURE						
						0.10	0.15	0.20	0.25	0.30	0.35	0.40
18/19/20CDX*X	1/2	OPTIONAL HIGH	GREEN	0.22	2.8	760	745	730	715	700	685	670
		STD. HIGH	ORANGE	0.17	2.1	670	650	630	615	600	588	570
		STD. LOW	YELLOW	0.14	1.6	570	555	540	520	500	480	---
25/26CDX*X	1/2	OPTIONAL HIGH	WHITE	0.30	3.8	980	960	940	920	900	875	850
		STD. HIGH	GREEN	0.25	3.0	890	870	850	830	810	790	770
		STD. LOW	ORANGE	0.21	2.5	800	775	750	725	700	675	---
		OPTIONAL LOW	YELLOW	0.18	2.0	730	710	690	670	650	630	---
30/31CDX*X	1/2	OPTIONAL HIGH	WHITE	0.40	4.7	1160	1145	1130	1115	1100	1080	1060
		STD. HIGH	GREEN	0.33	3.8	1060	1040	1020	1105	990	975	960
		STD. LOW	ORANGE	0.28	3.2	970	955	940	920	900	880	860
		OPTIONAL LOW	YELLOW	0.23	2.6	870	850	830	810	790	770	---
32CDX*X	1/2	OPTIONAL HIGH	WHITE	0.39	4.8	1220	1200	1180	1155	1125	1095	1065
		STD. HIGH	GREEN	0.27	3.2	1030	1005	985	960	940	920	900
		STD. LOW	ORANGE	0.22	2.5	905	885	860	840	820	800	---
		OPTIONAL LOW	YELLOW	0.16	1.8	725	705	685	670	650	630	---
37CDX*X	1/2 (2)	OPTIONAL HIGH	WHITE	0.45	5.6	1380	1360	1340	1320	1300	1280	1260
		STD. HIGH	GREEN	0.38	4.7	1290	1270	1250	1225	1200	1175	1150
		STD. LOW	ORANGE	0.31	3.7	1130	1105	1080	1055	1030	1010	---
		OPTIONAL LOW	YELLOW	0.26	3.0	1000	975	950	920	890	875	---

**NOTES:**

1. Units should not be applied to a system with less than 350 CFM/Ton airflow.
2. Shaded speeds are factory settings.
3. Add .05 static when enclosure and/or ceiling panel is used.
4. 37 CDXX has two motors and four blowers.

### CDX SERIES – WITH HOT WATER COILS

#### PSC MOTOR WITH HOT WATER COILS, NO PUMP

PERFORMANCE DATA CDXW								
UNIT MODEL	NOMINAL COOLING BTUH	PRESS. DROP (FT. WTR)	BTUH (1000) AT ENTERING WATER TEMPERATURE Delta -T 20°F & GPM					
			120°F	GPM	140°F	GPM	180°F	GPM
			18/19CDXW	18,000	0.7 2.0 3.3	10.3 12.0 12.9	1.0 1.2 1.3	14.4 16.8 18.0
20CDXW	18,000	0.8 2.1 4.1	10.9 12.9 13.7	1.1 1.3 1.4	15.3 18.0 19.2	1.5 1.8 1.9	24.0 28.3 30.2	2.4 2.8 3.0
25CDXW	24,000	2.1 4.1 6.6	14.7 15.9 16.5	1.5 1.6 1.7	20.6 22.2 23.1	2.1 2.2 2.3	32.4 34.9 36.3	3.2 3.5 3.6
26CDXW	24,000	2.2 4.3 6.8	15.7 17.0 17.6	1.6 1.7 1.8	22.0 23.8 24.7	2.2 2.4 2.5	34.6 37.4 38.8	3.5 3.7 3.9
30/31CDXW	30,000	2.2 4.3 6.8	17.3 18.8 19.6	1.7 1.9 2.0	24.2 26.3 27.5	2.4 2.6 2.8	38.0 41.3 43.2	3.8 4.1 4.3
32CDXW	30,000	2.8 5.4 8.5	18.4 20.1 21.1	1.8 2.0 2.1	25.8 28.2 29.5	2.6 2.8 3.0	40.5 44.3 46.4	4.1 4.4 4.6
37CDXW	36,000	2.8 5.4 8.5	19.7 21.7 22.8	2.0 2.2 2.3	27.6 30.4 31.9	2.8 3.0 3.2	43.4 47.8 50.1	4.3 4.8 5.0

#### NOTES:

1. Heat BTUH is at 70° F EAT.
2. Based on 20°F Delta - T. Velocity not to exceed 4ft./sec.
3. 120 degree and 180 degree data is supplied for boiler applications.
4. Heating BTUH output will not exceed output of water heater.
5. Approved for installation with 0" clearance to combustible material.
6. Use capacities when First Co. "Flow Control Module" is used (# 940-3CV).
7. Freeze protection standard on hot water and DX coils.

ELECTRICAL DATA CDXW					
UNIT MODEL	MOTOR (1)		MOTOR HP (120V)	MIN. CKT. AMPACITY (120V)	MAX. CKT. PROTECTION
	RPM	AMPS			
18/19/20CDXW	1550	2.3	1/5	3	15
25/26CDXW	1550	3.6	1/4	5	15
30/31CDXW	1550	4.6	1/5	6	15
32CDXW	1550	4.6	1/5	6	15
37CDXW	1550	4.6	1/5	6	15

## CDX SERIES - WITH HOT WATER COILS

ECM MOTOR WITH HOT WATER COILS, NO PUMP

PERFORMANCE DATA CDXWX								
UNIT MODEL	NOMINAL COOLING BTUH	PRESS. DROP (FT. WTR)	BTUH (1000) AT ENTERING WATER TEMPERATURE Delta-T-20°F & GPM					
			120°F	GPM	140°F	GPM	180°F	GPM
18/19CDXWX	18,000	0.7	10.3	1.0	14.4	1.4	22.6	2.3
		2.0	12.0	1.2	16.8	1.7	26.4	2.6
		3.3	12.9	1.3	18.0	1.8	28.3	2.8
20CDXWX	18,000	0.8	10.9	1.1	15.3	1.5	24.0	2.4
		2.1	12.9	1.3	18.0	1.8	28.3	2.8
		4.1	13.7	1.4	19.2	1.9	30.2	3.0
25CDXWX	24,000	2.1	14.7	1.5	20.6	2.1	32.4	3.2
		4.1	15.9	1.6	22.2	2.2	34.9	3.5
		6.6	16.5	1.7	23.1	2.3	36.3	3.6
26CDXWX	24,000	2.2	15.7	1.7	22.0	2.4	34.6	3.8
		4.3	17.0	1.9	23.8	2.6	37.4	4.1
		6.8	17.6	2.0	24.7	2.8	38.8	4.3
31CDXWX	30,000	2.2	17.3	1.7	24.2	2.4	38.0	3.8
		4.3	18.8	1.9	26.3	2.6	41.3	4.1
		6.8	19.6	2.0	27.5	2.8	43.2	4.3
32CDXWX	30,000	2.8	18.4	1.8	25.8	2.6	40.5	4.1
		5.4	20.1	2.0	28.2	2.8	44.3	4.4
		8.5	21.1	2.1	29.5	3.0	46.4	4.6
37CDXWX	36,000	2.8	19.7	2.0	27.6	2.8	43.4	4.3
		5.4	21.7	2.2	30.4	3.0	47.8	4.8
		8.5	22.8	2.3	31.9	3.2	50.1	5.0

**NOTES:**

1. Heat BTUH is at 70° F EAT.
2. Based on 20°F Delta - T. Velocity not to exceed 4ft./sec.
3. 120 degree and 180 degree data is supplied for boiler applications.
4. Heating BTUH output will not exceed output of water heater.
5. Approved for installation with 0" clearance to combustible material.
6. Use capacities when First Co. "Flow Control Module" is used (# 940-3CV).
7. Freeze protection standard on hot water and DX coils.

ELECTRICAL DATA CDXWX				
UNIT MODEL	MOTOR HP	AMPS	MIN. CIR AMPACITY	MAX CIR PROTECTION
		MOTOR		
18/19/20CDXWX	1/2	7.0	9	15
25/26CDXWX	1/2	7.0	9	15
31CDXWX	1/2	7.0	9	15
32CDXWX	1/2	7.0	9	15
37CDXWX	1/2 (2)	7.0	16	20

## PHYSICAL DIMENSIONS

### UNCASED VERSION WITH STANDARD PUMP

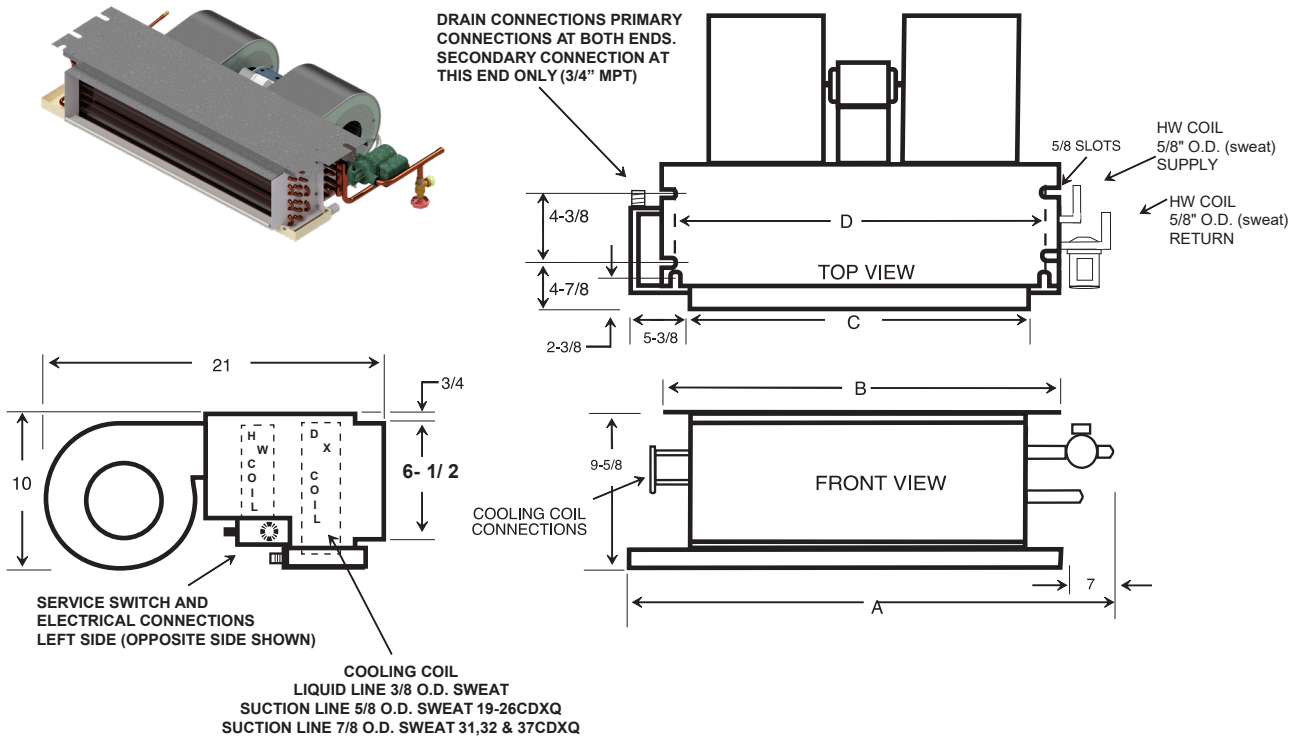

PHYSICAL DIMENSIONS				
UNIT MODEL	A	B	C	D
18/19CDXQ*	45-1/8	37-1/4	30-1/8	34-3/4
20-25CDXQ*	51-1/8	43-1/4	36-1/8	40-3/4
26/31CDXQ*	57-1/8	49-1/4	42-1/8	46-3/4
32/37CDXQ*	64-1/8	56-1/4	49-1/8	53-3/4

## CDXQ

### PSC MOTOR AND STANDARD PUMP

PERFORMANCE DATA CDXQ										
UNIT MODEL	NOMINAL COOLING BTUH	PRESS. DROP (FT. WTR)	BTUH (1000) AT ENTERING WATER TEMPERATURE Delta-T 20°F & GPM							
			120°F	GPM	130°F	GPM	140°F	GPM	180°F	GPM
18/19CDXQ*	18,000	3.3	12.9	1.3	15.4	1.5	18.0	1.8	28.3	2.8
20CDXQ*	18,000	4.1	13.7	1.4	16.5	1.7	19.2	1.9	30.2	3.0
24/25CDXQ*	24,000	4.1	15.9	1.6	19.0	1.9	22.2	2.2	34.9	3.5
26CDXQ*	24,000	4.3	17.0	1.7	20.4	2.0	23.8	2.4	37.4	3.7
30/31CDXQ*	30,000	4.3	18.8	1.9	22.5	2.3	26.3	2.6	41.3	4.1
32CDXQ*	30,000	5.4	20.1	2.0	24.2	2.4	28.2	2.8	44.3	4.4
37CDXQ*	36,000	5.4	21.7	2.2	26.1	2.6	30.4	3.0	47.8	4.8

**NOTES:**

1. Heat BTUH is at 70° F EAT.
2. 120° F and 180° F data is supplied for boiler applications.
3. Heating BTUH output will not exceed output of water heater.
4. Approved for installation with 0" clearance to combustible material.
5. Freeze protection on hot water and DX coils.
6. Based on 20° F Delta-T, Velocity not to exceed 4ft./sec.

ELECTRICAL DATA CDXQ					
UNIT MODEL	MOTOR HP (120V)	AMPS (120V)		MIN. CIR AMPACITY	MAX CIR PROTECTION
		MOTOR	PUMP		
18/19/20CDXQ*	1/5	2.3	0.57	4	15
24CDXQ*	1/5	3.0	0.57	5	15
25/26CDXQ*	1/4	3.6	0.57	6	15
30/31CDXQ*	1/5	4.6	0.57	7	15
32CDXQ*	1/5	4.6	0.57	7	15
37CDXQ*	1/5	4.6	0.57	7	15

## CDXQX

### ECM MOTOR AND STANDARD PUMP

PERFORMANCE DATA CDXQX										
UNIT MODEL	NOMINAL COOLING BTUH	PRESS. DROP (FT. WTR)	BTUH (1000) AT ENTERING WATER TEMPERATURE Delta-T 20°F & GPM							
			120°F	GPM	130°F	GPM	140°F	GPM	180°F	GPM
18/19CDXQ*X	18,000	3.3	12.9	1.3	15.4	1.5	18.0	1.8	28.3	2.8
20CDXQ*X	18,000	4.1	13.7	1.4	16.5	1.7	19.2	1.9	30.2	3.0
25CDXQ*X	24,000	4.1	15.9	1.6	19.0	1.9	22.2	2.2	34.9	3.5
26CDXQ*X	24,000	4.3	17.0	1.7	20.4	2.0	23.8	2.4	37.4	3.7
31CDXQ*X	30,000	4.3	18.8	1.9	22.5	2.3	26.3	2.6	41.3	4.1
32CDXQ*X	30,000	5.4	20.1	2.0	24.2	2.4	28.2	2.8	44.3	4.4
37CDXQ*X	36,000	5.4	21.7	2.2	26.1	2.6	30.4	3.0	47.8	4.8

**NOTES:**

1. Heat BTUH is at 70° F EAT.
2. 120° F and 180° F data is supplied for boiler applications.
3. Heating BTUH output will not exceed output of water heater.
4. Approved for installation with 0" clearance to combustible material.
5. Freeze protection on hot water and DX coils.
6. Based on 20° F Delta-T, Velocity not to exceed 4ft./sec.

ELECTRICAL DATA CDXQX					
UNIT MODEL	MOTOR HP	AMPS		MIN. CIR AMPACITY	MAX CIR PROTECTION
		MOTOR	PUMP		
18/19/20CDXQ*X	1/2	7.0	0.57	10	15
25/26CDXQ*X	1/2	7.0	0.57	10	15
31CDXQ*X	1/2	7.0	0.57	10	15
32CDXQ*X	1/2	7.0	0.57	10	15
37CDXQ*X	1/2 (2)	7.0	0.57	17	20



## CDXR PSC MOTOR AND HI FLOW PUMP

The CDXR series fan coils are designed specifically for use with tankless water heaters. These fan coils allow high efficiency tankless water heaters to be used for two jobs instead of one.... providing domestic hot water and high efficiency space heating! They are compatible with most of today's higher efficiency split-systems heat pumps and condensing units .

The CDXR fan coils include a special circulating pump designed for tankless heaters, HW check valve, air purge valve, hot water coil, cooling coil, blower/motor, and multi-function circuit board. The fan coil with the -C is factory installed within an insulated enclosure or "case" and is shipped with your choice of either a solid or louvered access panel with attractive off-white powder coat finish. Solid panels must be used with ducted return air applications, while louvered panels (the default style) should be used with non-ducted return air applications. Louvered panels include filters, but solid panels require field supplied return-air filter/louvers.

PERFORMANCE DATA CDXR*										
UNIT MODEL	NOMINAL COOLING BTUH	PRESS. DROP (FT. WTR)	BTUH (1000) AT ENTERING WATER TEMPERATURE Delta-T 20°F & GPM							
			120°F	GPM	130°F	GPM	140°F	GPM	180°F	GPM
18/19CDXR*	18,000	3.3	12.9	1.3	15.4	1.5	18.0	1.8	28.3	2.8
20CDXR*	18,000	4.1	13.7	1.4	16.5	1.7	19.2	1.9	30.2	3.0
25CDXR*	24,000	4.1	15.9	1.6	19.0	1.9	22.2	2.2	34.9	3.5
26CDXR*	24,000	4.3	17.0	1.7	20.4	2.0	23.8	2.4	37.4	3.7
31CDXR*	30,000	4.3	18.8	1.9	22.5	2.3	26.3	2.6	41.3	4.1
32CDXR*	30,000	5.4	20.1	2.0	24.2	2.4	28.2	2.8	44.3	4.4
37CDXR*	36,000	5.4	21.7	2.2	26.1	2.6	30.4	3.0	47.8	4.8

### NOTES:

1. Heat BTUH is at 70° F EAT.
2. 120° F and 180° F data is supplied for boiler applications.
3. Heating BTUH output will not exceed output of water heater.
4. Approved for installation with 0" clearance to combustible material.
5. Freeze protection on hot water and DX coils.
6. Based on 20° F Delta-T, Velocity not to exceed 4ft./sec.

ELECTRICAL DATA CDXR*					
UNIT MODEL	MOTOR HP (120V)	AMPS (120V)		MIN. CIR AMPACITY	MAX CIR PROTECTION
		MOTOR	PUMP		
18/19/20CDXR*	1/5	2.3	0.84	4	15
25/26CDXR*	1/4	3.6	0.84	6	15
30/31CDXR*	1/5 (2)	4.6	0.84	7	15
32CDXR*	1/5 (2)	4.6	0.84	7	15
37CDXR*	1/5 (2)	4.6	0.84	7	15

## CDXR<sup>X</sup>

ECM MOTOR AND HI FLOW PUMP

PERFORMANCE DATA CDXR* X										
UNIT MODEL	NOMINAL COOLING BTUH	PRESS. DROP (FT. WTR)	BTUH (1000) AT ENTERING WATER TEMPERATURE Delta-T 20°F & GPM							
			120°F	GPM	130°F	GPM	140°F	GPM	180°F	GPM
18/19CDXR*X	18,000	3.3	12.9	1.3	15.4	1.5	18.0	1.8	28.3	2.8
20CDXR*X	18,000	4.1	13.7	1.4	16.5	1.7	19.2	1.9	30.2	3.0
25CDXR*X	24,000	4.1	15.9	1.6	19.0	1.9	22.2	2.2	34.9	3.5
26CDXR*X	24,000	4.3	17.0	1.7	20.4	2.0	23.8	2.4	37.4	3.7
31CDXR*X	30,000	4.3	18.8	1.9	22.5	2.3	26.3	2.6	41.3	4.1
32CDXR*X	30,000	5.4	20.1	2.0	24.2	2.4	28.2	2.8	44.3	4.4
37CDXR*X	36,000	5.4	21.7	2.2	26.1	2.6	30.4	3.0	47.8	4.8

**NOTES:**

1. Heat BTUH is at 70° F EAT.
2. 120° F and 180° F data is supplied for boiler applications.
3. Heating BTUH output will not exceed output of water heater.
4. Approved for installation with 0" clearance to combustible material.
5. Freeze protection on hot water and DX coils.
6. Based on 20° F Delta-T, Velocity not to exceed 4ft./sec.

ELECTRICAL DATA CDXR*X					
UNIT MODEL	MOTOR HP	AMPS		MIN. CIR AMPACITY	MAX CIR PROTECTION
		MOTOR	PUMP		
18/19/20CDXR*X	1/2	7.0	.84	10	15
25/26CDXR*X	1/2	7.0	.84	10	15
31CDXR*X	1/2	7.0	.84	10	15
32CDXR*X	1/2	7.0	.84	10	15
37CDXR*X	1/2 (2)	7.0	.84	17	20

---

# GUIDE SPECIFICATIONS

## UNIT

All fan coils are manufactured with 20 to 22 gauge galvanized steel to resist corrosion.

All units are approved for installation with "0" clearance to combustible material.

Piping, drain, and wiring connections are readily accessible, and mounting holes and/or slots are predrilled to save installation time and field labor expense.

Exposed units and/or panels have a baked on powder coat finish.

## COILS

Coils have 3/8" O.D. copper tubing expanded to high efficiency aluminum fins.

Each coil is factory tested to 450 psig.

## DRAIN PANS

Drain pan is made from heavy gauge galvanized steel with "folded corner joints".

Drain pan is insulated with a U.L. Listed, closed cell, fire retardant foam insulation to prevent sweating.

## BLOWER ASSEMBLIES

All blower wheels are centrifugal, forward curved, and dynamically balanced for smooth, quiet operation.

Blower assemblies can be easily removed for service.

## MOTORS

Standard motors are PSC type with internal thermal overload protection. Motors have permanently lubricated sleeve bearings for long life. All motors are resiliently mounted with rubber bushings to assure quiet, vibration-free operation and are easily removed.

ECM motors have multi-speed connections or a jumper to change speeds. Motors have permanently lubricated sleeve bearings for long life. All motors are resiliently mounted with rubber bushings to assure quiet, vibration-free operation and are easily removed.

Water coils and pumps shall be NSF/ASNI 169:2016 certified for public health and should contain less than 2% lead. All water coils should have a check valve internal to the pump and have an air purge valve factory-installed.



*AMERICAN-MADE. FAMILY OWNED.*



FIRST CO.  
P.O. BOX 270969 - DALLAS, TEXAS 75227  
PH. (214) 388-5751 | FAX (214) 388-2255  
[WWW.FIRSTCO.COM](http://WWW.FIRSTCO.COM)

**NOVEMBER 2024**